

**ORGANIZATIONAL, DIRECT SUPPORT AND GENERAL SUPPORT
MAINTENANCE MANUAL
FOR**

LOADER

SCOOP TYPE, DED 4 X 4

ARTICULATED FRAME STEER,

2 1/2 CUBIC YARD BUCKET (CCE)

AIRBORNE/AIRMOBILE,

SECTIONALIZED AND NONSECTIONALIZED

MODEL 950BS

NSN 3805-01-126-7914

MODEL 950BSCE

NSN 3805-01-260-5162

MODEL 950BNS

NSN 3805-01-126-7915

MODEL 950BNSCE

NSN 3805-01-260-5163

This technical manual is an authentication of the manufacturers commercial literature and does not conform with the format and content specified in AR 25-30, Military Publications. This technical manual does, however, contain available information that is essential to the operation and maintenance of the equipment.

*This publication supersedes TM 5-3805-258-24-2 dated August 1987

Approved for public release; distribution is unlimited

HEADQUARTERS, DEPARTMENT OF THE ARMY

AUGUST 1991

WARNINGS

WARNING

Batteries discharge highly explosive hydrogen gas and can explode and shower you with sulfuric acid if a spark is created near the battery. Batteries can also cause injuries when a ring or watch completes a circuit between the positive battery post and the frame of the machine. To prevent injuries always remove all rings and watches and wear safety glasses while work is done on or near the batteries. Use extra caution not to cause sparks near the battery. Disconnect the ground cable first and connect it last.

WARNING

Do not disconnect the airlines until the air pressure in the system is at zero.

WARNING

The cover of the fuel transfer pump is under spring tension.

WARNING

To prevent possible personal injury, make sure the locks on the valve stem are in their correct position on the valve stem when the compressor is released.

WARNING

Release the pressure in the air reservoir before any lines are disconnected from the engine.

WARNING

When the machine is to be lifted, transported on another vehicle or service work is to be performed near the center of the machine, connect anti-pivot link between front and rear frames to keep the machine in a straight ahead position. Before operation and when operating, be sure the anti-pivot link, located near loser center of the machine, is disconnected and pinned to the retaining plates. There is no clearance for a man in this area when the vehicle is being turned.

WARNING

Retainer and the ring on the transmission hydraulic control valves have spring pressure on them. Use care to prevent injury when the retainer is removed from the valve spool.

WARNINGS

WARNING

Spring pressure is present behind plug in loader control valve. To prevent personal injury, carefully remove plug.

WARNING

Spring pressure is present in housing. To prevent personal injury, carefully remove housing.

WARNING

Spring pressure is present behind sleeves in the pilot control valve. To prevent personal injury, carefully remove jam nuts.

WARNING

A bolt holds the spring under compression in the steering control valve. To prevent personal injury, carefully remove bolt.

WARNING

To prevent personal injury when removing the hydraulic tank, stop the engine, lower the bracket to the ground, and move the control levers backward and forward to release the pressure in the hydraulic system. Slowly loosen the cap to release the pressure in the hydraulic tank. Let the hydraulic oil become cool before any lines are disconnected in the hydraulic system.

WARNING

Spring pressure is present inside the baake chamber. To prevent serious personal injury, follow the instructions in this manual and use correct tooling.

WARNING

Make sure the floor jack and the hoist are moved with the rear frame when connecting the rear frame to the front frame.

WARNING

Serious personal injury can be the result if spring force is not carefully released when springs are disconnected from the housing assembly of the seat.

WARNING

Housing assembly on the seat is under spring force. Put a downward force on the housing assembly and remove the shafts. Release the housing assembly slowly until the spring force on it is released.

WARNINGS

WARNING

If NBC exposure is suspected, all air filter media should be handled by personnel wearing protective equipment. Consult your unit NBC Officer or NBC NCO for appropriate handling or disposal instructions.

TECHNICAL MANUAL

HEADQUARTERS
DEPARTMENT OF THE ARMY
Washington D.C., 9 August 1991

ORGANIZATIONAL, DIRECT SUPPORT AND GENERAL SUPPORT
MAINTENANCE MANUAL FOR
LOADER, SCOOP TYPE, DED 4X4
ARTICULATED FRAME STEER, 2 1/2 CUBIC YARD BUCKET (CCE)
AIRBORNE/AIRMOBILE, SECTIONALIZED AND NONSECTIONALIZED
MODEL 950BS; MODEL 950BSCE; MODEL 950BNS; MODEL 950BNSCE

REPORTING ERRORS AND RECOMMENDING IMPROVEMENTS

You can help improve this manual. If you find any mistakes, or if you know of a way to improve the procedures, please let us know. Mail your letter, DA Form 2028 (Recommended Changes to Publications and Blank Forms), or DA Form 2028-2, located in the back of this manual, directly to: Commander, U. S. Army Tank-Automotive Command, ATTN: AMSTA-MB, Warren, MI 48397-5000. A reply will be furnished to you.

TABLE OF CONTENTS
DISASSEMBLY AND ASSEMBLY
ENGINE INDEX

Air Cleaner Housing	5-10	Fan	5-21
Air Compressor		Fan Drive	5-23
Models 950BNS & 950 BS	5-12	Flywheel	5-156
Models 950BSCE & 950BNSCE	5-18a	Flywheel Housing	5-157
Alternator	5-12a	Fuel Filter Base and Filter	5-91
Batteries	5-5	Fuel Injection Lines	5-76
Balancer Shafts	5-135	Fuel Injection Nozzles	5-77
Balancer Shaft Bearings	5-136	Fuel Injection Pump Housing and Governor	5-92
Camshaft	5-137	Fuel Injection Pump Housing Disassembly and Assembly	5-98a
Camshaft Bearing	5-139	Fuel Injection Pumps (See Fuel Injection Pump Housing Dis- assembly and assembly)	5-78
Connecting Rod Bearings	5-142	Fuel Priming and Primary Filter Pump Group	5-84
Crankshaft and Gear	5-145	Fuel Ratio Control	5-80
Crankshaft Front Seal and Wear Sleeve	5-59	Fuel Shutoff Solenoid	5-80
Crankshaft Main Bearings	5-143	Fuel Tank	5-160
Crankshaft Pulley	5-58	Fuel Transfer Pump	5-86
Crankshaft Rear Seal and Wear Sleeve	5-159	Fuel Transfer Pump (Disassembly and Assembly) Models 950BS and 950BNS)	5-87
Cylinder Head	5-124	Models 950BSCE and 950BNSCE	5-90
Cylinder Liners	5-140		
Electric Starting Motor	5-12d		
Engine	5-148		
Engine Front Support	5-69		
Engine Oil Cooler	5-57		
Exhaust Manifold	5-79		

*This publication supercedes TM 5-3805-258-24-2 dated August 1987

ENGINE INDEX (Cont)

Governor (Disassembly and Assembly) Models 950BS and 950BNS.	5-19	Spacer Plate	5-130
Models 950BSCE and 950BNSCE.	5-20a	Timing Gear Cover	5-71
Hood	5-6	Timing Gear and Plate	5-73
Muffler	5-9	Torque Converter Oil Cooler	5-37
Oil Filter Base	5-55	Turbocharger	5-49
Oil Pan	5-60	Turbocharger, Disassembly and Assembly	5-51
Oil Pan Plate	5-63	Valve Cover	5-120
Oil Pump	5-64	Valve Lifters	5-131
Pistons	5-131	Water Pump	5-28
Piston Cooling Orifices	5-147	Water Pump, Disassembly and Assembly	5-31
Radiator, Hydraulic Oil Cooler and Guard Models 950BS and 950BNS	5-39	Water Temperature Regulator.	5-36
Models 950BSCE and 950BNSCE	5-42a		
Radiator and Hydraulic Oil Cooler Models 950BS and 950BNS	5-43		
Models 950BSCE and 950BNSCE.	5-48a		
Rocker Shaft and Push Rods	5-121		

POWER TRAIN INDEX

Anti-Pivot Link Connection and Separation	5-163	Tires and Rims	5-164
Axles	5-166	Torque Converter and Transmission	5-236
Center Drive Shaft	5-195	Torque Converter, Disassembly and Assembly	5-238
Drive Shaft Carrier Bearing	5-191	Torque Converter Outlet Relief Valve	5-217
Engine, Torque Converter, Transmission and Transfer Gears	5-220	Transfer Gears	5-299
Engine, Torque Converter, Transmission and Transfer Gears Separation and Connection	5-235	Transmission, Disassembly and Assembly	5-262
Final Drive	5-168	Transmission Hydraulic Control Valve	5-251
Final Drive Planet Carriers	5-169	Transmission Hydraulic Control Valve, Disassembly and Assembly	5-255
Front Axle Housing	5-182	Transmission Oil Filter	5-209
Standard Differential	5-197	Transmission Oil Filter, Disassembly and Assembly	5-210
Front Drive Shaft	5-195	Transmission Oil Pump	5-213
Front and Rear Differentials	5-199	Transmission Oil Pump, Disassembly and Assembly	5-214
No-Spin Differential	5-198	Wheels, Bearings and Duo-Cone Seals	5-170
Rear Axle Housing	5-183	Wheel Spindles	5-180
Rear Axle Housing Front Support	5-185	Wheel Brakes	5-175
Rear Axle Housing Rear Support.	5-187	Wheel Brakes, Disassembly and Assembly	5-177
Rear Drive Shaft	5-196		

VEHICLE SYSTEMS INDEX

Air Dryer5-430a	Parking Brake5-454
Air/Hydraulic Cylinder Group5-441	Parking Brake Chamber5-448
Air\Hydraulic Cylinder Group, Disassembly and Assembly.5-443	Pilot and Hydraulic Pump5-394a
Air Reservoir5-430	Pilot Control Valve5-338
Brake Quick Release Valve5-459	Selector and Pressure Control Valve5-348
Bucket Cylinders5-372a	Steering Control Make-Up Valve	5-386a
Bucket Positioner Control5-324	Steering Control Valve Manifold 950BS and 950BNS5-384
Foot-Operated Brake Valves5-431	950BSCE and 950BNSCE5-386
Hand Metering Pump5-435	Steering Control Valve 950BS and 950BNS5-386b
Hydraulic oil Filters5-410	950BSCE and 950BNSCE5-388
Hydraulic Tank5-412	Steering Cylinders5-373
Lift Cylinders5-362	Steering Neutralizer Valves5-380
Lift Kickout Control5-323	Supplemental Steering Gear Pump5-394
Loader Control Valves5-326	Tilt Cylinders5-350
Loader Frame5-318	Tilt Link and Lever5-31
Loader Main Frame, Separation and Connection 950BS and 950BNS5-461	Transmission Neutralizer Group 950BS and 950BNS5-425
950BSCE and 950BNSCE5-476	950BSCE and 950BNSCE5-426a

OPERATOR'S STATION INDEX

Adjustable Steering Column5-507	Instrument Panel5-496
Brake Pedal5-505	Mirror5-495
Fuse Panel5-493	Parking Brake Cable 950BS and 950BNS5-491
Governor Pedal Group 950BS and 950BNS5-501	950BSCE and 950BNSCE5-492a
950BSCE and 950BNSCE5-504a	Rollover Protective Structure (ROPS)5-519
Hydraulic Control Group5-520	Seat5-476m
		Steering Wheel5-490

SUPPLEMENTAL OPERATING MAINTENANCE INSTRUCTIONS

Refer to page 5-531 (Includes MAC Chart and PMCS)

TABLE OF CONTENTS

Lubrication and Maintenance: Refer to Operator's Manual
Specifications: Refer to Maintenance Manual Volume 1
Systems Operation: Refer to Maintenance Manual Volume 1
Testing and Adjusting: Refer to Maintenance Manual Volume 1
Disassembly and Assembly: This volume.

BATTERIES

REMOVE BATTERIES

1401-11

WARNING

Batteries discharge highly explosive hydrogen gas and can explode and shower you with sulfuric acid if a spark is created near the battery. Batteries can also cause burn injuries when a ring or watch completes a circuit between the positive battery post and the frame of the machine. To prevent injuries always remove all rings and watches and wear safety glasses while work is done on or near the batteries. Use extra caution not to cause sparks near the battery. Disconnect the ground cable first and connect it last.

NOTE: Make sure the disconnect switch is in the "OFF" position.

1. Open access panels on the rear frame.
2. Disconnect cable assemblies (1) from the batteries.
3. Remove nuts (3) from the rods.
4. Remove plates (4) that hold batteries (2) in place.
5. Use battery carriers and two people to remove batteries (2) from the machine. The weight of each battery is 26 kg (58 lb.).

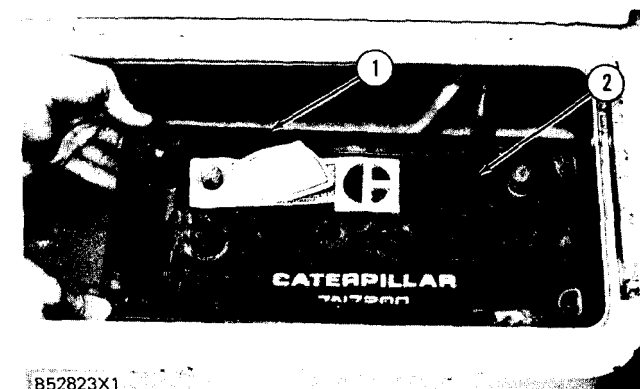
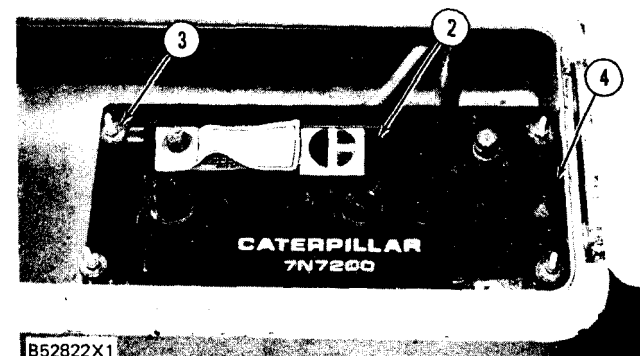
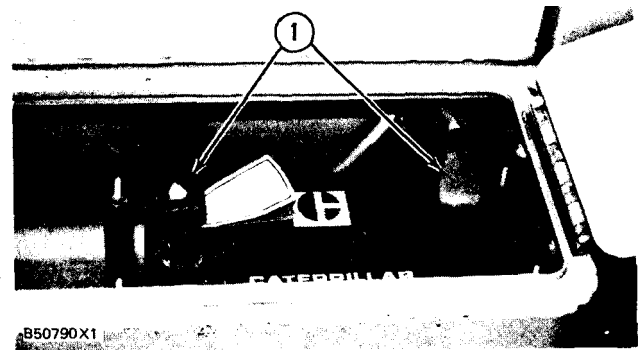

INSTALL BATTERIES

1401-12

1. Put batteries (2) into position in the machine.
2. Install plates (1) on the batteries as shown.
3. Install nuts (4) that hold the plates in place.
4. Connect cable assemblies (3) to the batteries.
5. Close the access panels.

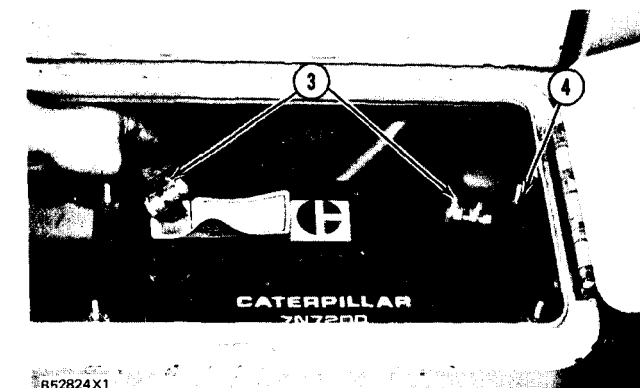

HOOD

REMOVE HOOD

7251-11

1. Loosen the bolt that holds clamp (2) in place.

2. Remove exhaust pipe (1) from the machine.

3. Remove the wing nut, cover (3) and body (4) from the base assembly.

4. Remove base assembly (5) from the machine.

NOTE: It can be necessary to use heat on the base to remove it from the air cleaner housing.

5. Open door assemblies (6) and (7) from both sides of the machine.

6. Remove bolts (8) from the rear of the hood.

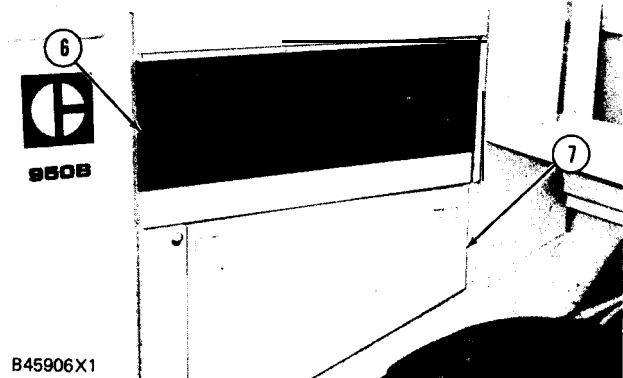
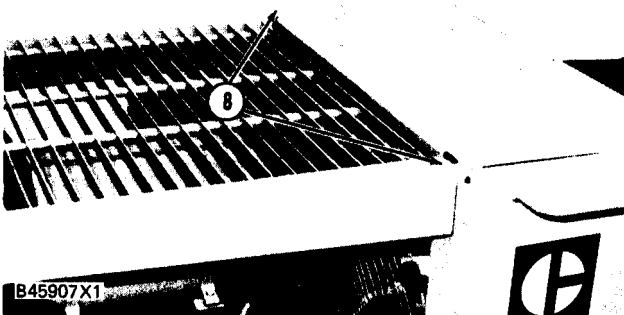
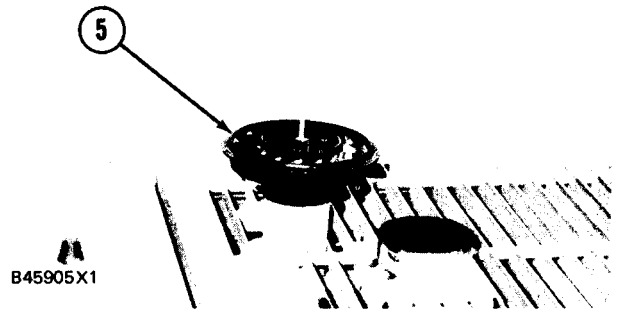
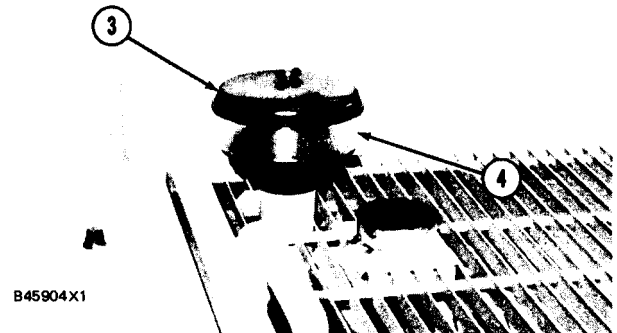
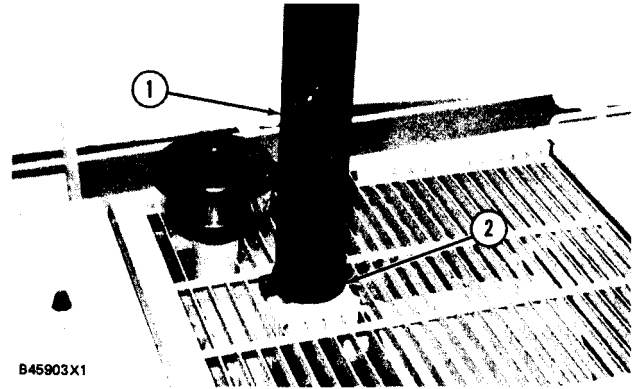

ENGINE

HOOD

7. Remove bolts (9) from each side of the rear hood.

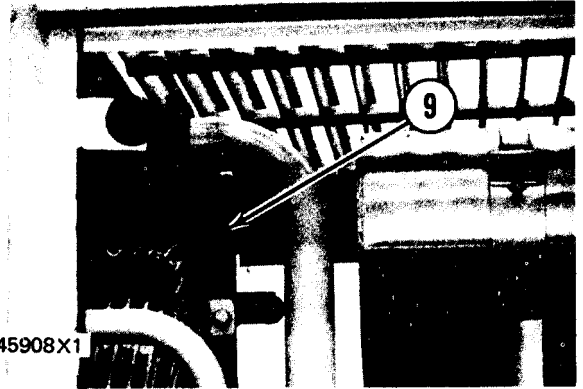

8. Remove three nuts (10) from the front of the hood.

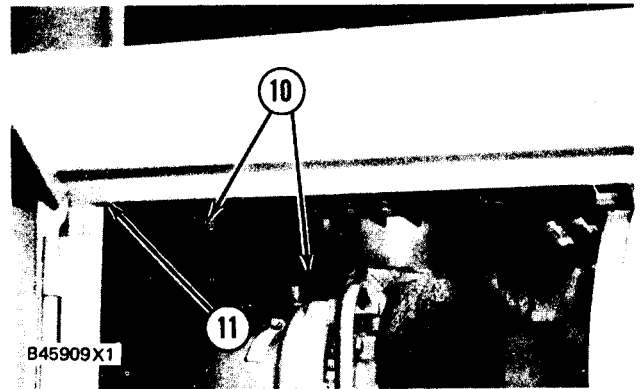

9. Remove two bolts (11) (not shown) from each side of the front of the hood.

10. Fasten straps (12) and a hoist to hood (13) as shown. Remove hood (13) from the machine. The weight of the hood is 52 kg (115 lb.).



INSTALL HOOD

7251-11

1. Fasten straps (1) and a hoist to hood (2).

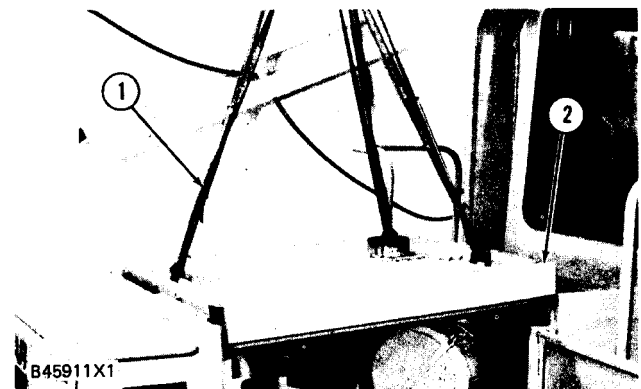

2. Put hood (2) in position on the machine as shown.

3. Install nuts (3) that hold the front of the hood to the machine.

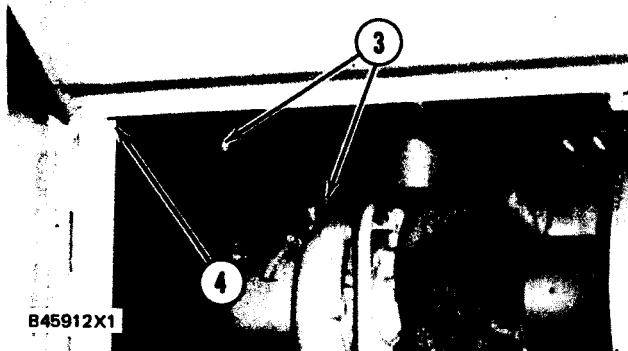

4. Install two bolts (4) (not shown) on each side of the front hood.

HOOD

5. Install bolts (5), two each side of the front head.

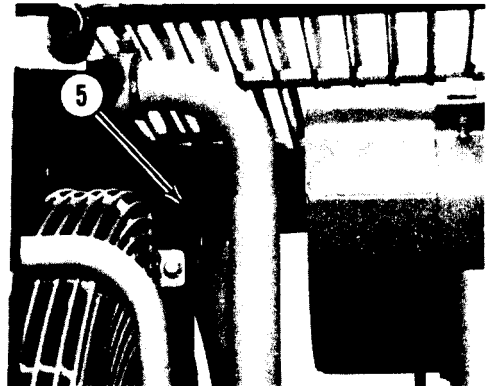

B45913X1

6. Install bolts (6) to the top of the rear hood.

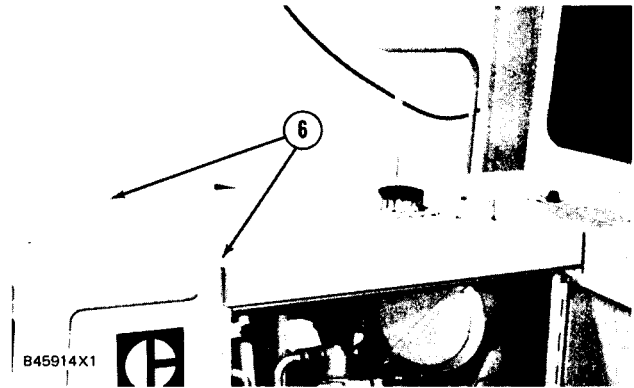

B45914X1

7. Close the door assemblies on each side of the machine.

8. Install hose assembly (7) on the air cleaner housing.

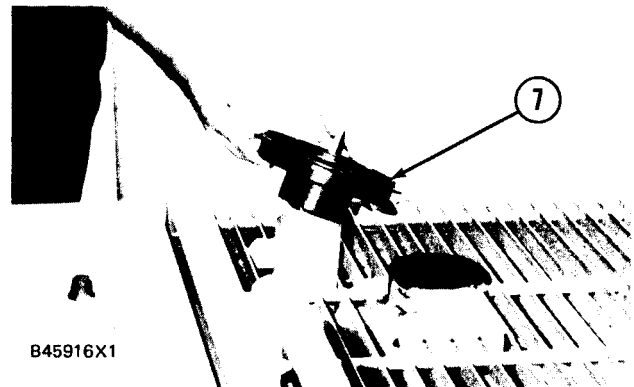

B45916X1

9. Install body (9) and cover (8) on the base assembly.

10. Install exhaust pipe (10) and clamp (11) on the machine.

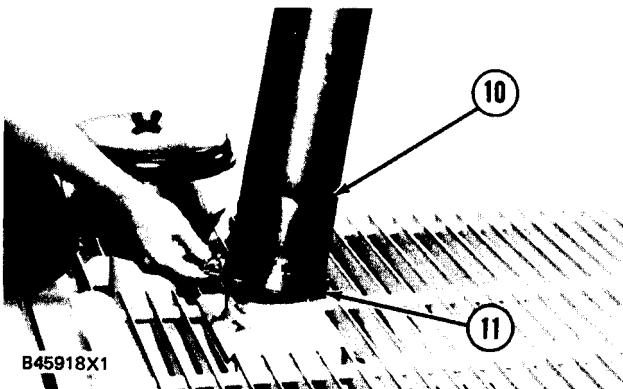

B45918X1

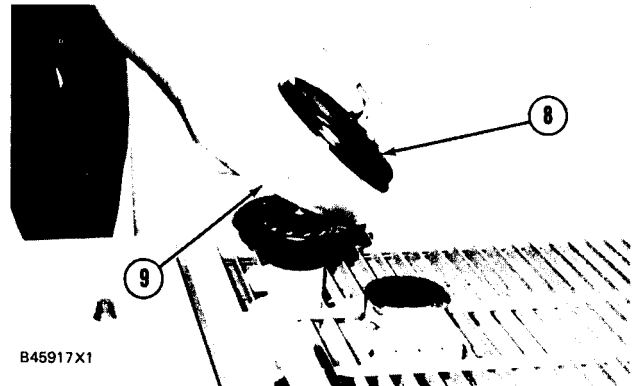

B45917X1

ENGINE

MUFFLER

REMOVE MUFFLER

1062-11

start by:
a) remove hood

1. Remove bolts (2) and clamps (1) from the muffler.

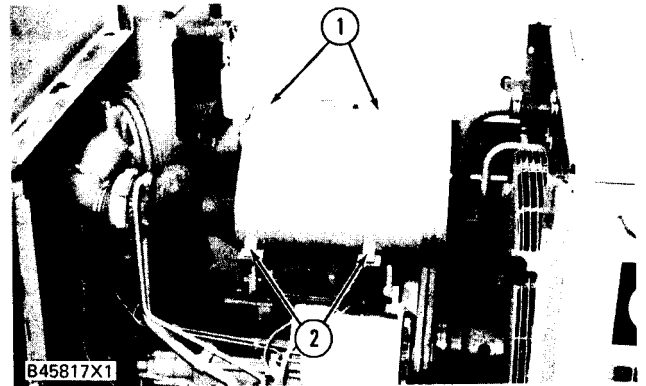

2. Fasten strap (3) and a hoist to muffler (4).

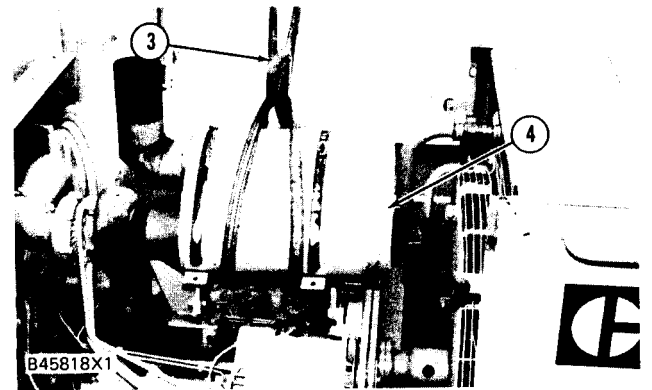

3. Move muffler (4) toward the rear of the machine to make a separation of the muffler from the turbocharger. Remove the muffler.

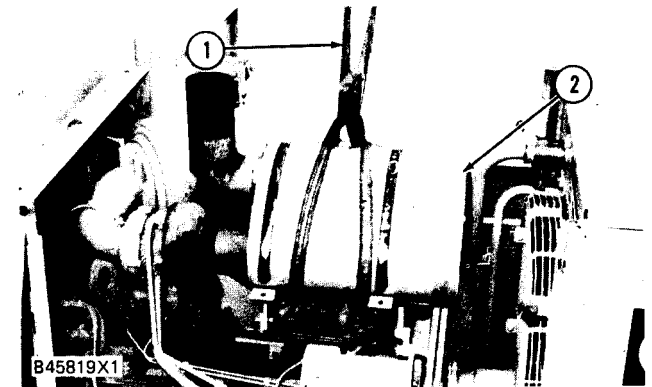

INSTALL MUFFLER

1062-12

1. Fasten a strap (1) to muffler (2). Put the muffler in position and make a connection between the muffler and the turbocharger.

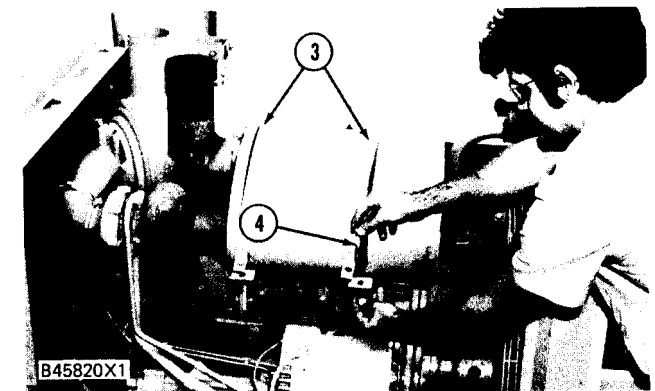

2. Put clamps (3) in position on the muffler and install bolts (4) that hold them in place.

AIR CLEANER HOUSING

REMOVE AIR CLEANER HOUSING 1051-11

- start by:
a) remove hood

WARNING

If NBC exposure is suspected, all air filter media should be handled by personnel wearing protective equipment. Consult your unit NBC Officer or NBC NCO for appropriate handling or disposal instructions.

1. Disconnect tube (1) from the air cleaner bracket.
2. Loosen clamp (2) that holds the hose to the air cleaner bracket.
3. Remove bolts (4) and remove air cleaner assembly (3) from the machine.

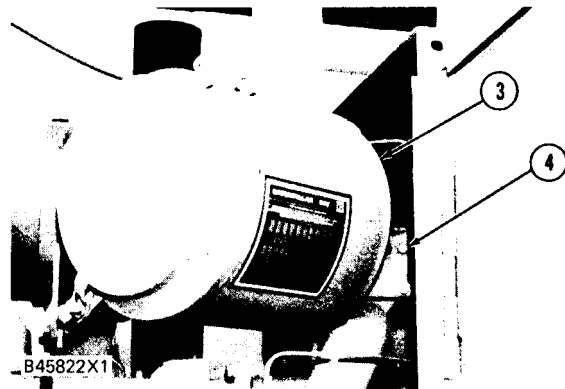
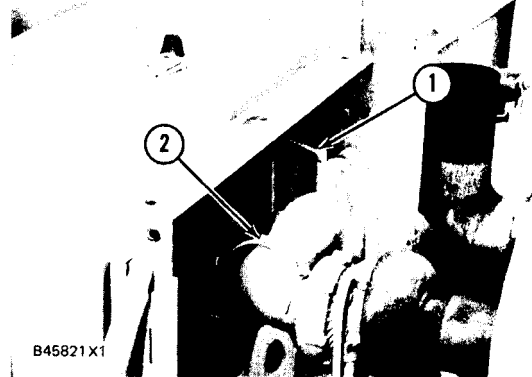

INSTALL AIR CLEANER HOUSING 1051-12

1. Put air cleaner assembly(1) into position on the machine and install the bolts that hold it.

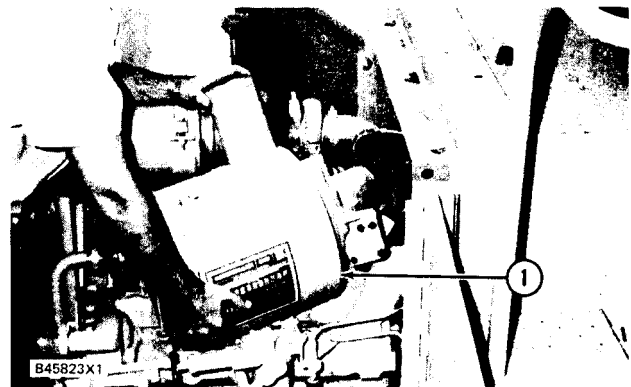

2. Tighten clamp (2) that holds the hose to the air cleaner assembly.

3. Connect tube assembly (3) to the air cleaner assembly.

- end by:
a) remove hood

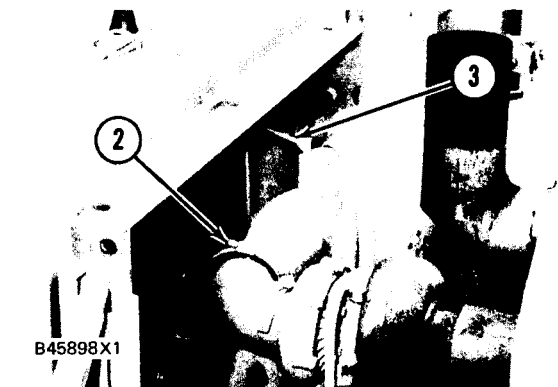

ENGINE

ALTERNATOR

REMOVE ALTERNATOR

1405-11

1. Disconnect wires (1) from the alternator.
2. Loosen two nuts (2) on the adjusting rod.
3. Remove vee belts (4) from the alternator pulley.
4. Remove bolts (5) and alternator (3) from the engine.

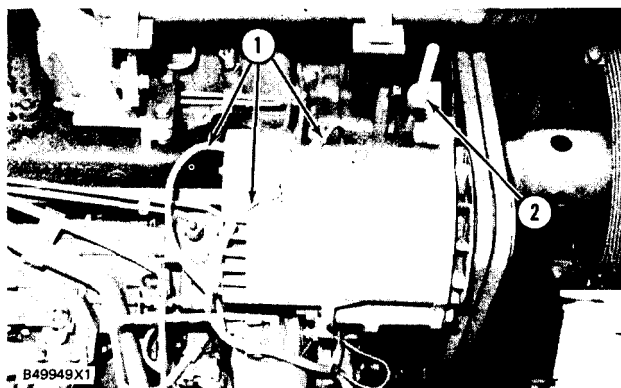

INSTALL ALTERNATOR

1405-12

1. Put alternator (5) in position on the engine.
2. Connect wires (1) on the alternator as shown.
3. Install vee belts (4) on the alternator pulley. Adjust the belts. See the V-BELT TENSION CHART at the bottom of the page. Tighten nuts (2) and bolts (3) after the belt tension is adjusted.

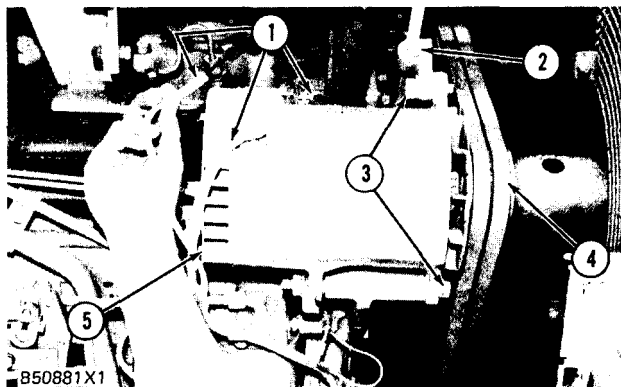
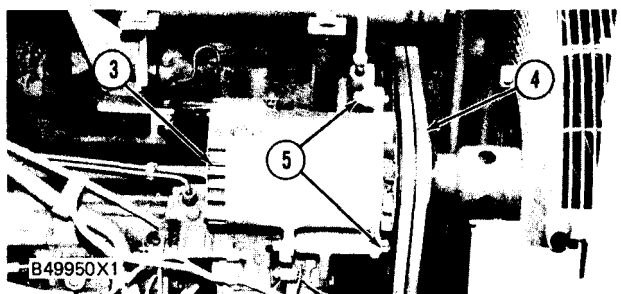

NOTE: When the tension in a vee belt is measured, measure the belt farthest from the engine block. When a replacement of one belt in a vee belt set is necessary, a replacement of the complete set must be made.

V-BELT TENSION CHART										
BELT SIZE	WIDTH BELT TOP		WIDTH TOP OF PULLEY GROOVE		BELT TENSION "INITIAL"*		BELT TENSION "USED"***		BORROUGHS GAUGE NUMBERS	
	mm	in.	mm	in.	GAUGE READING		GAUGE READING		OLD GAUGE NO.	NEW GAUGE NO.
					N	lb.	N	lb.		
3/8	10.72	.422	9.65	.380	445±22	100±5	400±22	90 ± 5	BT-33-73F	BT-33-95
1/2	13.89	.547	12.70	.500	534±22	120±5	400±44	90 ± 10	BT-33-96-4-16	BT-33-95
5V	15.88	.625	15.24	.600	534±22	120±5	400±44	90 ± 10	BT-33-72-4-15	BT-33-72C
11/16	17.48	.688	15.88	.625	534±22	120±5	400±44	90 ± 10	BT-33-72-4-15	BT-33-72C
3/4	19.05	.750	17.53	.690	534±22	120±5	400±44	90 ± 10	BT-33-72-4-15	BT-33-72C
15/16	23.83	.938	22.30	.878	534±22	120±5	400±44	90 ± 10	BT-33-72-4-15	BT-33-72C
MEASURE TENSION OF BELT FARTHEST FROM THE ENGINE										
**"INITIAL" BELT TENSION is for a new belt.										
***"USED" BELT TENSION is for a belt which has more than 30 minutes of operation at rated speed of engine.										

A10232-1X1

ENGINE

ELECTRIC STARTING MOTOR

REMOVE ELECTRIC STARTING MOTOR

1453-11

1. Disconnect the battery cables from the batteries. See REMOVE BATTERIES.

NOTE: For models 950BNSCE and 950BSCE, remove starter receptacle wires from starter motor and solenoid.

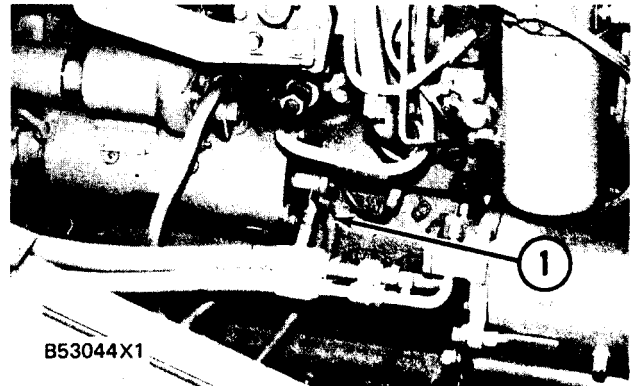

2. Put identification on wires (1) and disconnect them from the starter.

3. Put identification on wires (2) and (4) and disconnect them from the solenoid.

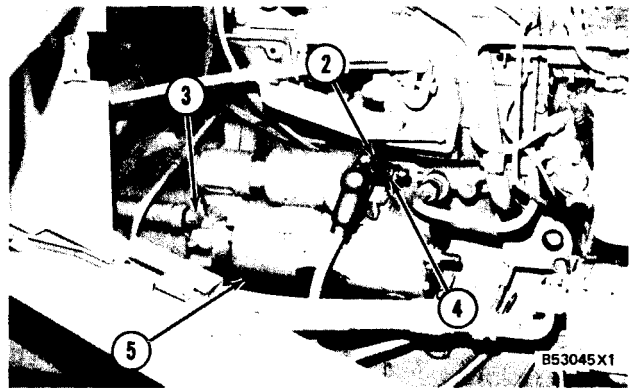

4. Remove bolts (3) and starter (5). The weight of the starter is 27 kg (60 lb.).

INSTALL ELECTRIC STARTING MOTOR

1453-12

1. Put gasket(1) in position and install starter (2) on the flywheel housing.

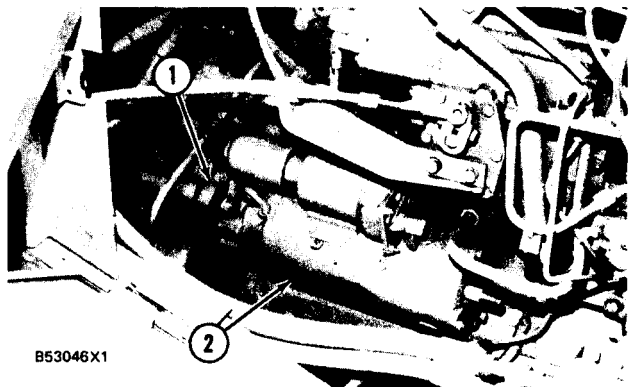

2. Connect wires (3) to the solenoid and wires (4) to the starter.

NOTE: For models 950BNSCE and 950BSCE, connect starter receptacle wires to starter motor and solenoid.

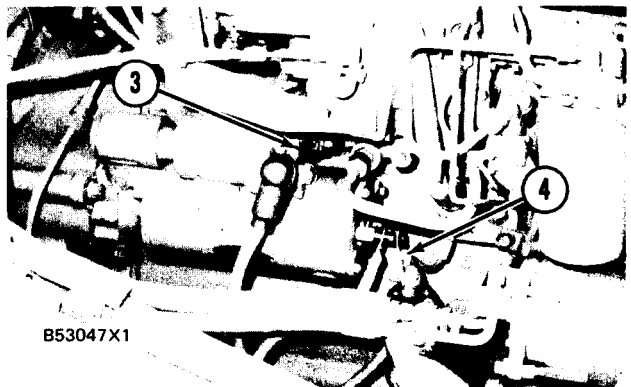

3. Connect the battery cables to the batteries. See INSTALL BATTERIES.

ENGINE

ALTERNATOR

DISASSEMBLE ALTERNATOR 9G9538 (Bosch)

Tooling Needed		A	B	C
	Soldering iron (180 watt)			
	Vise or Clamping support (with V-blocks)			
	Mandrel Press			
6V2166	Puller Group	1		
5F7465	Puller			1
9S9152	Bearing Pulling Attachment			1
1P456	Spacer			1
5S9603	Bolt (3/8 -16 NC, 5 in. long)			2
5M2894	Washer (3/8" flat)			2
1P74	Slide Hammer Group		1	
2P2312	Legs		2	
	5/8 - 18 Hardened Flat Washer		1	
	5/8 - 18 Jam Nut		1	

1. Position alternator in vise or similar clamping device.

NOTE: Care must be taken not to damage alternator by overtightening the vise.

2. Remove pulley nut (not shown) and remove pulley and fan from alternator.
3. Remove two screws (1) from regulator cover (2).
4. Use a 3/8" wrench to remove nut (3) from (D+) terminal (4). Disconnect suppression capacitor lead (5).

NOTE: This step may be unnecessary if this component is not to be tested or replaced.

5. Remove two screws (6) and pull regulator (7) partially away from frame to expose regulator terminals (8 and 9). The small diameter screw (8) is D+. The large diameter screw (9) is DF.
6. Disconnect two leads from D+ terminal (8) and one lead from DF terminal (9).
7. Mark rear housing (10), stator frame (11) and drive end shield (12) for proper alignment.

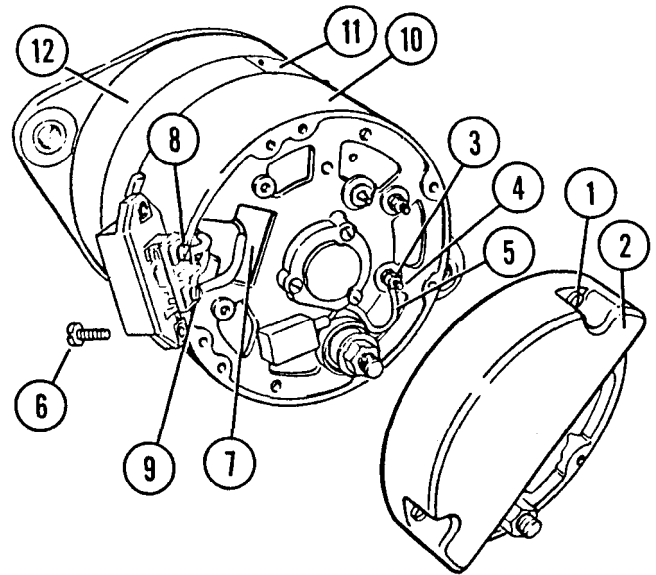

8. Remove four hex-socket head capscrews (13). Separate drive end shield (12) and rotor as an assembly from the rear housing (10) and stator frame (11).

9. Position drive end shield and rotor assembly (14) along with tooling in press.

10. Press out rotor (15) from drive end shield (12).

CAUTION

Take care not to damage bearing (16) while pressing out rotor.

11. Remove ring spacer (17).

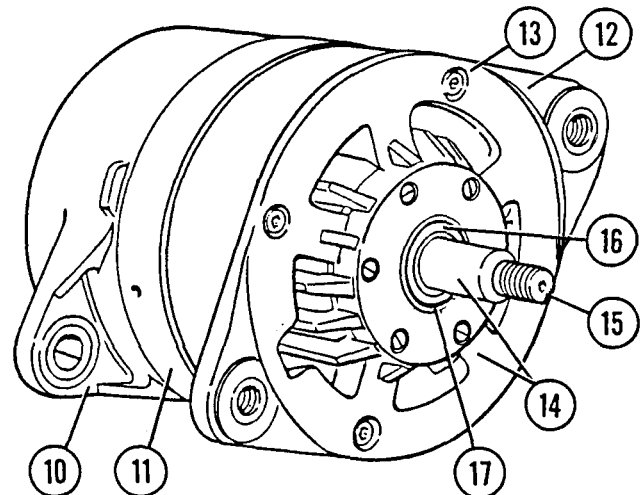

ENGINE

ALTERNATOR

12. Inspect bearing inner race (18) on rotor shaft (19) (rectifier end).
13. Only remove bearing (16) if worn or damaged. Replace both bearing (16) and bearing race (18) if bearing is replaced. Use bearing race puller (tooling C) to remove bearing race (18).
14. Remove epoxy from deep groove (20) in drive end shield.

CAUTION

Epoxy putty covers field winding lead (21) in next step. Care must be taken when removing this epoxy so that the lead is not damaged.

15. Remove six screws (22) on front side of drive end shield.
16. Remove pole body (field coil winding) (23) and lead (21).
17. Remove intermediate ring (24).
18. Remove bearing (16) from seat in drive end shield.
19. Disconnect three stator phase windings (25) from the three rectifier bridge terminals (26) by unsoldering and straightening the bent over leads.
20. Remove stator frame (11) from rear housing (10).

CAUTION

When unsoldering the (R) terminal, do not grip the soldering sleeve around its outside diameter. The sleeve will collapse with too much pressure. While heating with iron, grip the edge with long nose pliers.

21. Unsolder the soldering sleeve from terminal "R".
22. Remove two screws (27).

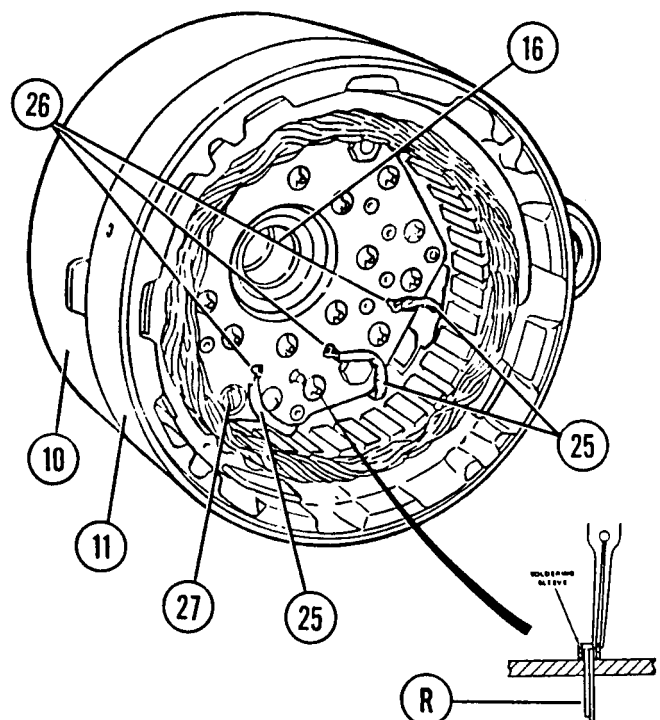
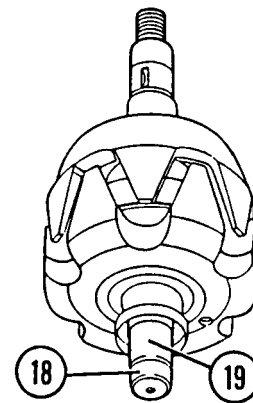
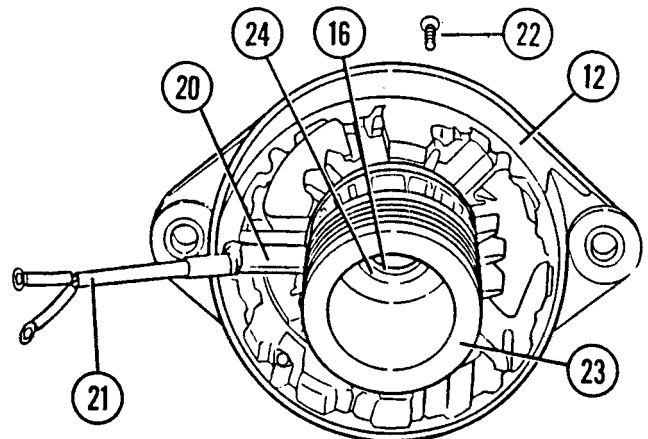

ALTERNATOR

23. Remove two rectifier terminal retaining nuts (28) using a 9/16" wrench, two washers (29) and insulator (30) from outside of rear frame assembly.
24. Remove two rectifier terminal retaining nuts (31) using a 3/8" wrench, two lockwashers (32), washer (33) and insulator (34).
25. Remove two rectifier terminal retaining nuts (35) using a 3/8" wrench and washers (36).

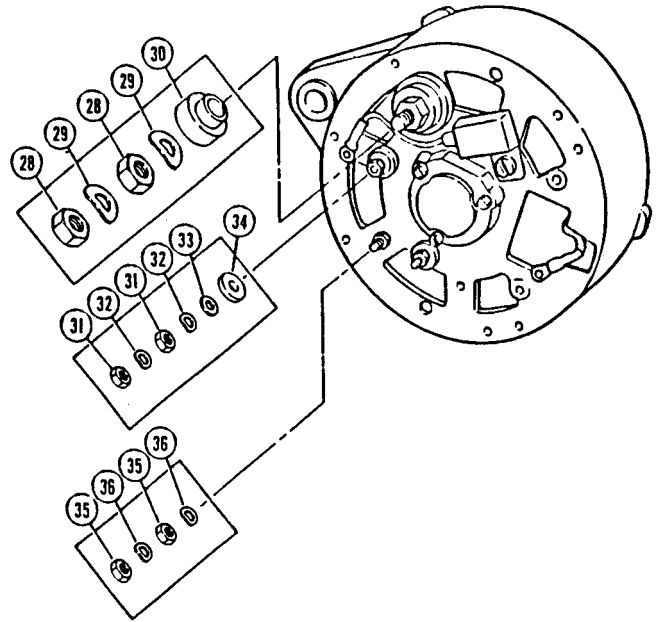

26. Remove three screws (37).

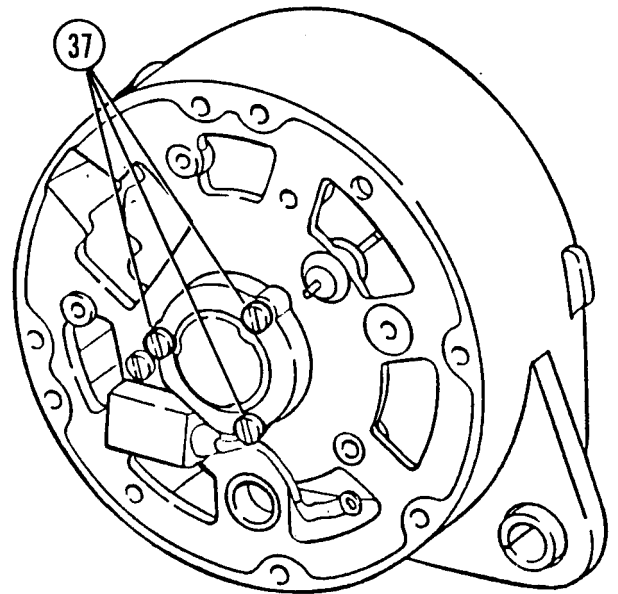

27. Remove ring (38) from rear frame.
28. Remove roller bearings (39) and retaining cage (40) with tooling C.

CAUTION

If bearing is removed in this step, it will be destroyed.

29. Remove bearing outer race (41) with tooling B.

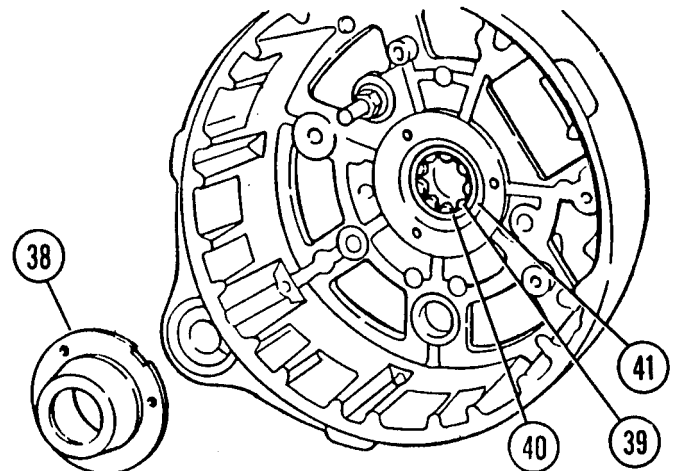

ALTERNATOR

ASSEMBLE ALTERNATOR 9G9538 (Bosch)

1. If removed, install bearing race (41) into housing (10).
2. Install roller bearings (39) and retaining cage (40) in rear frame with bearing installation tool.
3. Install ring (38) into rear frame.

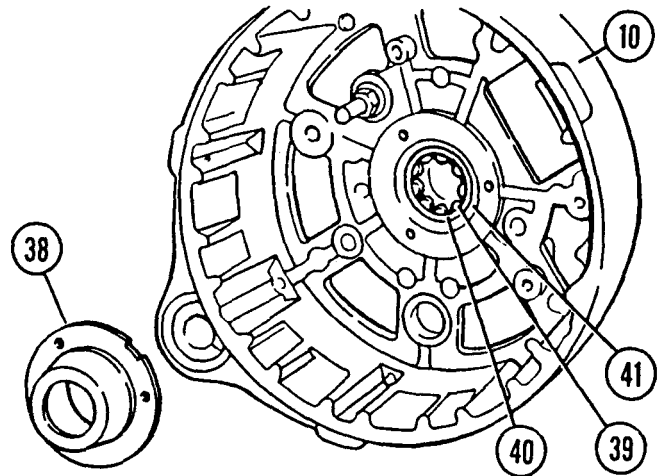

4. Install three screws (37) into housing (10).

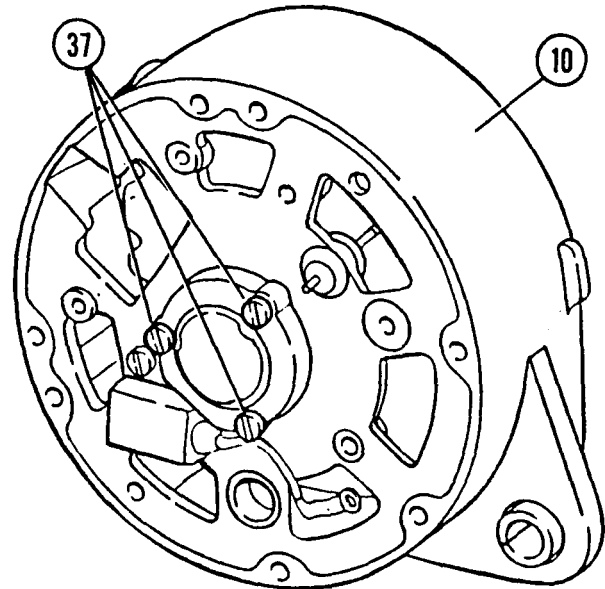

5. Install two washers (36) and use a 3/8" wrench to install two nuts (35).
6. Install insulator (34), washers (33), two lockwashers (32) and use a 3/8" wrench to install two retaining nuts (31).
7. Install insulator (30), two washers (29) and use a 9/16" wrench to install two retaining nuts (28).

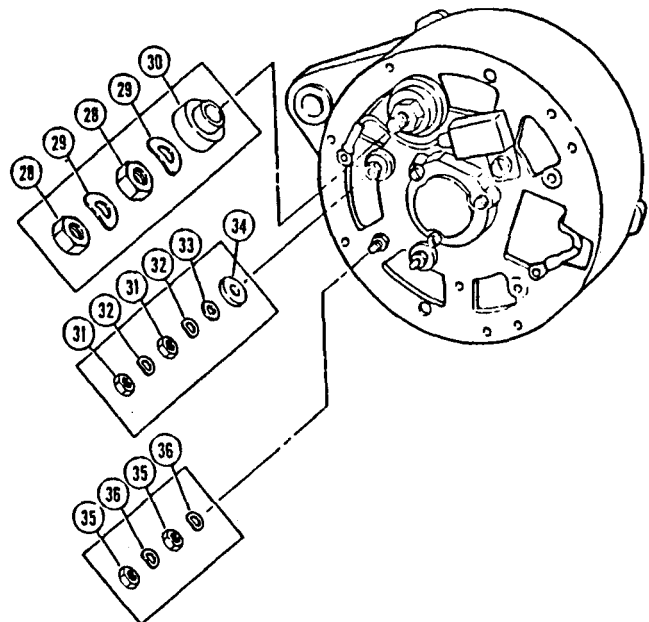

ALTERNATOR

8. Install two screws (27).
9. Install "R" terminal, if removed, by soldering the soldering sleeve to the terminal.
10. Position stator frame (11) on rear frame (10). Align the marks made during disassembly.
11. Solder three phase stator winding leads (25) to rectifier terminals (26).
12. If removed, install bearing (16) in drive end frame (12).

NOTE: This is a loose fit bearing.

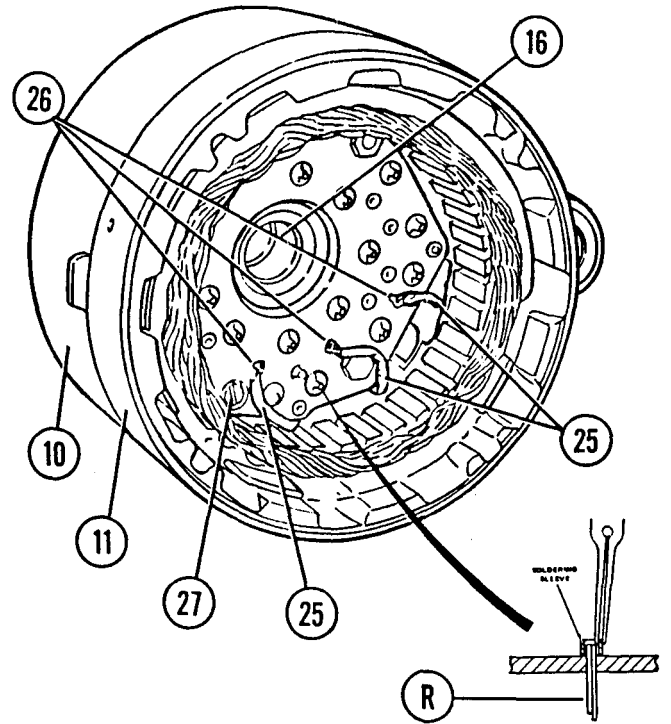

13. Install intermediate ring (24) in drive end frame (12).
14. Install field coil winding (23). Winding leads (21) must fit in deep groove (20). Install six screws (22). Apply epoxy putty over lead and groove.
15. Install spacer ring (25).

CAUTION

In the next step, the spacer ring must be supported so that the bearing inner race is supported.

16. Install rotor assembly (15) in drive end frame (12) using a press.
17. Heat bearing race (18) to 275°F. Install bearing race on rotor shaft (19).

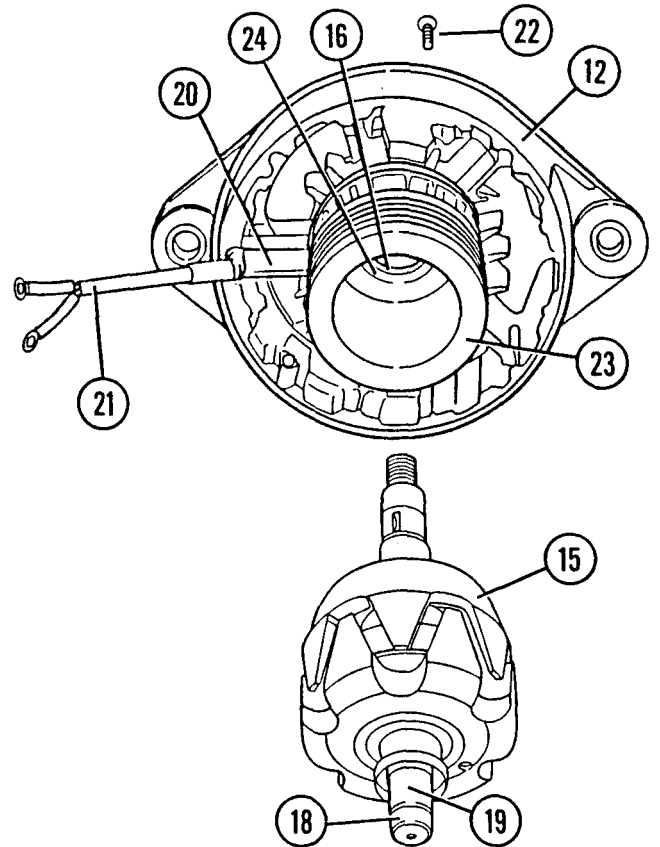

ENGINE

ALTERNATOR

18. Connect drive end shield (12) and rotor (15) as an assembly (14) to the rear housing (10) and stator frame assembly (11). Use marks made during disassembly to help alignment.
19. Install four hex-socket head capscrews (13). **DO NOT TIGHTEN.**
20. Insert three 0.3 mm (0.01 in.) feeler gauges between rotor and stator. Tighten screws (13) to a torque of 3 to 4 ft. lbs. Remove feeler gauges.

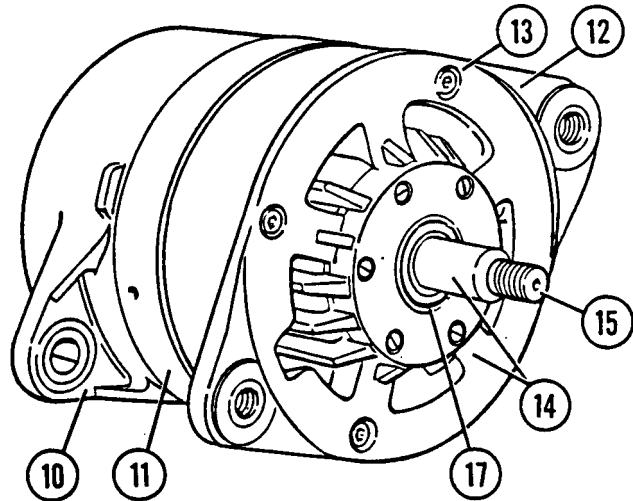

21. Connect the field coil lead (with large diameter hole) to the regulator (7) with a large diameter screw (9). Connect the rectifier lead and the remaining field coil winding lead to the regulator terminal (7). with a small diameter screw (8).

NOTE: To maintain the proper field coil lead polarity, one field coil lead has a small diameter hole.

22. Place regulator (7) on rear frame assembly and install two screws (6).
23. Install suppression capacitor lead (5) on the D+ terminal (4) and install nut (3) using a 3/8" wrench.
24. Install regulator cover (2) and install two screws (1).

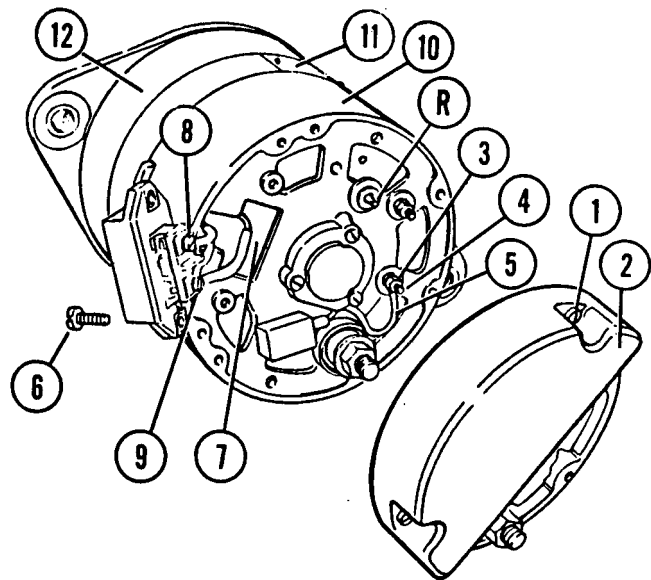

BOSCH ALTERNATOR TESTING AND ADJUSTING

ALTERNATOR TESTS

Tools Needed:

- 6V3030 Digital Multimeter
- 6V3032 Test Leads
- Test Lamp 24V 10W
- Generate; Test Bench

Suppression Capacitor Test

Remove cover plate from rectifier. Disconnect suppression capacitor lead (1) from D+ terminal. Connect ohmmeter between suppression capacitor lead and terminal B(-).

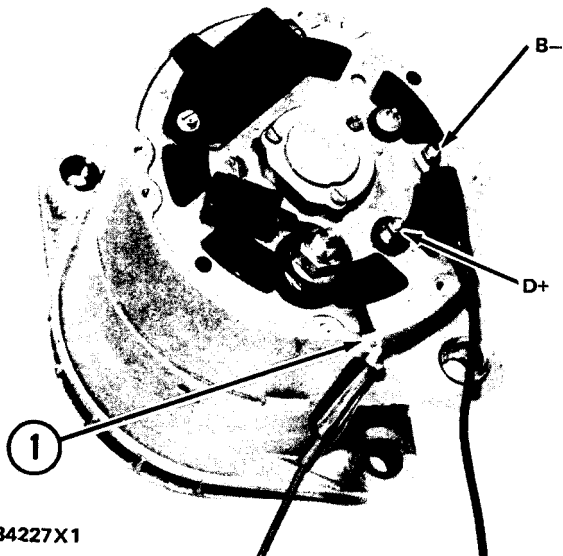

B34227X1

SUPPRESSION CAPACITOR TEST
1. Suppression capacitor lead.

If the meter reading is not 200K ohms or more, then replace the suppression capacitor.

WARNING

Discharge the suppression capacitor after testing. This prevents the igniting of cleaning fluid from sparks caused by capacitor discharge.

Pole Body (Stationary Field Coil) Tests

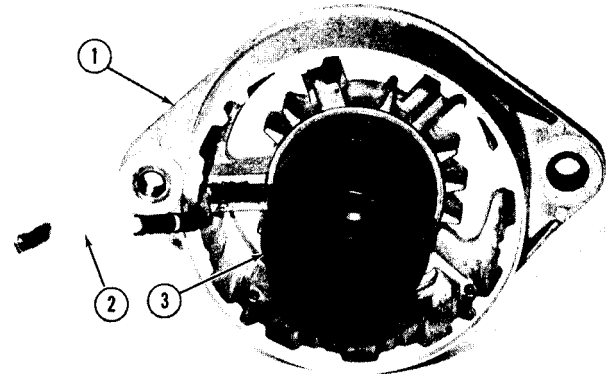

B34219X1

POLE BODY
(Alternator Disassembled for Illustration Purposes)
1. End frame. 2. Field winding leads. 3. Winding pole.

Remove regulator cover and regulator.

Winding Continuity Test

Connect ohmmeter between the field winding leads (2).

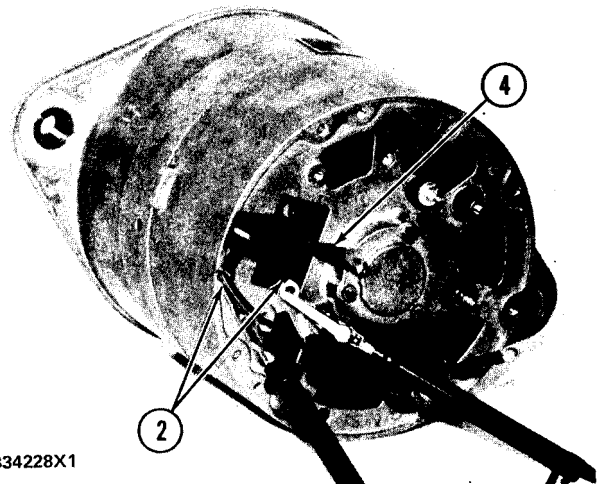

B34228X1

POLE BODY WINDING CONTINUITY TEST
2. Field winding leads. 4. Rectifier bridge lead.

The resistance should be 7 to 9 ohms.

If the resistance test values are not correct, there is an open or short between the windings (2).

Winding To Frame Test

Connect ohmmeter between the (B-) terminal and each of the two field coil winding leads (2). Each of the two readings should be high (indicating no shorts to frame).

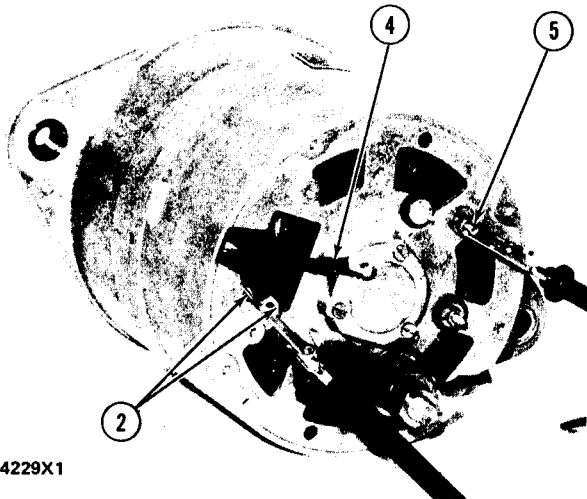

B34229X1

POLE BODY WINDING TO FRAME TEST

2. Field winding leads. 4. Rectifier bridge lead. 5. Terminal (B-).

Stator Winding to Frame Test

Connect the ohmmeter between each of the three stator windings and the frame (three readings). Resistance values should be very high (an indication of no shorts to frame).

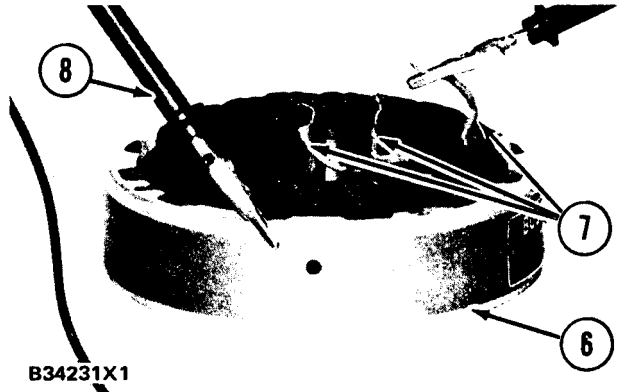

B34231X1

**STATOR WINDING TO FRAME TEST
(Test Other Two Leads As Shown)**

6. Stator. 7. Phase leads. 8. Test lead to frame.

Stator Test

Stator Winding Continuity Test

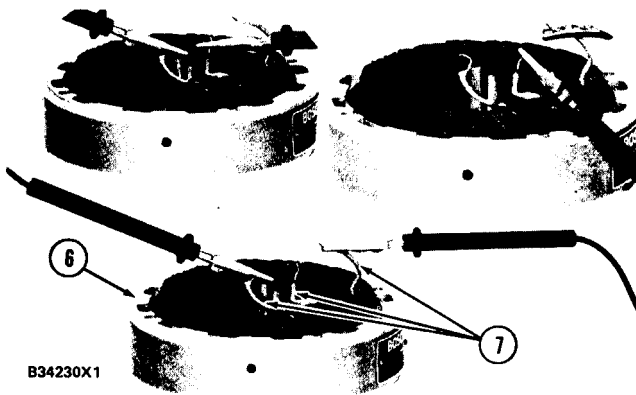

B34230X1

STATOR WINDING CONTINUITY TEST

6. Stator. 7. Phase leads.

Remove stator (6) from frame assembly. Connect ohmmeter between pairs of the three stator winding leads (7) (three readings). Resistance should be .15 to .25 ohms.

If the resistance test values are not correct, then the stator (6) has a defect.

Rectifier Test

Unsolder stator winding leads (7) from rectifier and remove stator (6). Disconnect capacitor lead from (D+) terminal. On the ohmmeter checks that follow, make one check then reverse the ohmmeter leads. One reading should be high and one low. If not, the rectifier has a defect and should be replaced.

Minus Diode Check

Connect ohmmeter between each rectifier solder phase terminal (9) and the frame (ground).

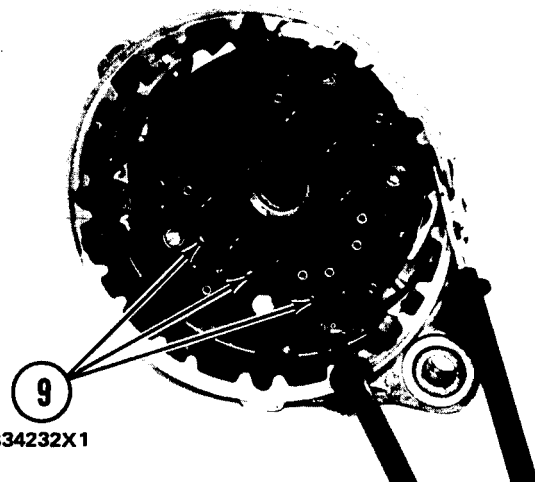

B34232X1

MINUS DIODE CHECK

9. Bridge rectifier terminals.

ENGINE

TESTING

Positive Diode Check

Connect ohmmeter between each rectifier solder phase terminal (9) and the (B+) terminal (12).

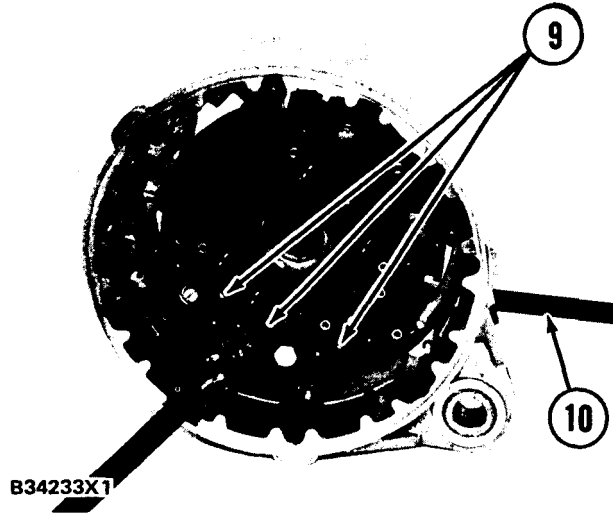

**POSITIVE DIODE CHECK
(Inside View)**

9. Bridge rectifier terminals. 10. To the (B+) terminal (12).

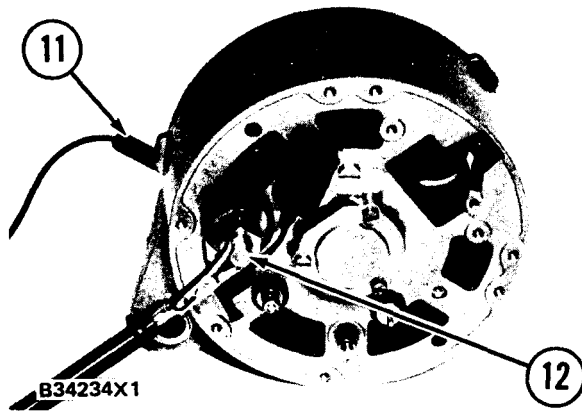

**POSITIVE DIODE CHECK
(Outside View)**

11. To the bridge rectifier terminals (9). 12. (B+) terminal.

Excitation Diode Check

Connect ohmmeter between each rectifier solder phase terminal (9) and the D+ terminal (14).

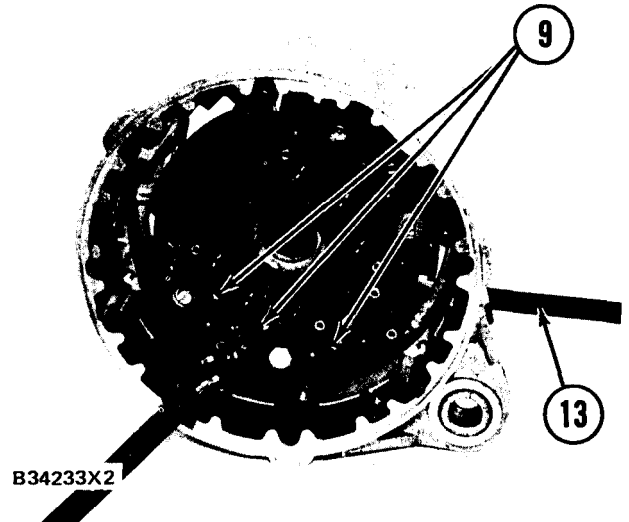

**EXCITATION DIODE CHECK
(Inside View)**

9. Bridge rectifier terminals. 13. To the (D+) terminal (14).

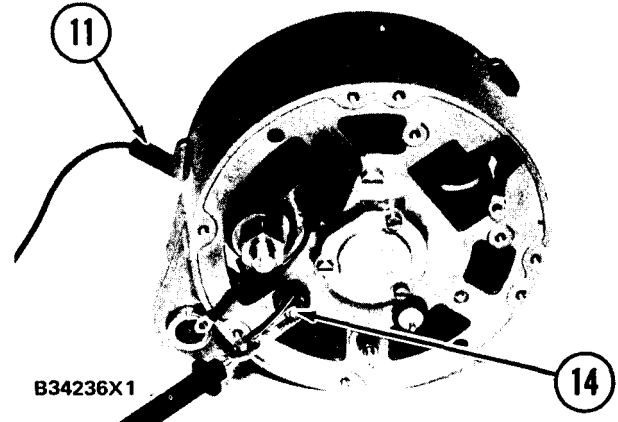

**EXCITATION DIODE CHECK
(Outside View)**

11. To the bridge rectifier terminals. 14. (D+) terminal.

REGULATOR TEST

Precautions

Do not recharge battery during tests. Generator must not be in operation (rotating) when the regulator is connected and disconnected. Alternator and voltmeter must each be connected in parallel (across) with the battery.

Disconnect the battery from the generator only when the generator is not in rotation. Do not operate the alternator without the battery.

Test Conditions and Connections

Regulator and generator cold [approximately 20° C (68° F)]. Carbon pile is connected in parallel with the battery.

Negative battery cable to generator terminal (D-) or (B-). Positive battery cable to ammeter. From ammeter to generator terminal (B+).

Voltmeter leads to generator terminals (B+) and (D-) or (B-).

CAUTION

Observe correct polarity when connecting voltmeter.

If needed for pre-excitation (only after assembly), connect a 24V indicator lamp (3 watt) between battery positive and generator D+ terminal. This procedure is needed when a new rotor is installed.

Test Procedure

Adjust generator speed to 5,000 RPM.

Set load current to 5A by adjusting the carbon pile. In one minute, the regulated voltage reading should be 27.5V to 28.3V.

NOTE: If the generator has been disassembled and then assembled with a new rotor, the generator must first be externally excited through a 3 watt, 24V lamp or 3 watt resistor. Thereafter, the generator is self-excited.

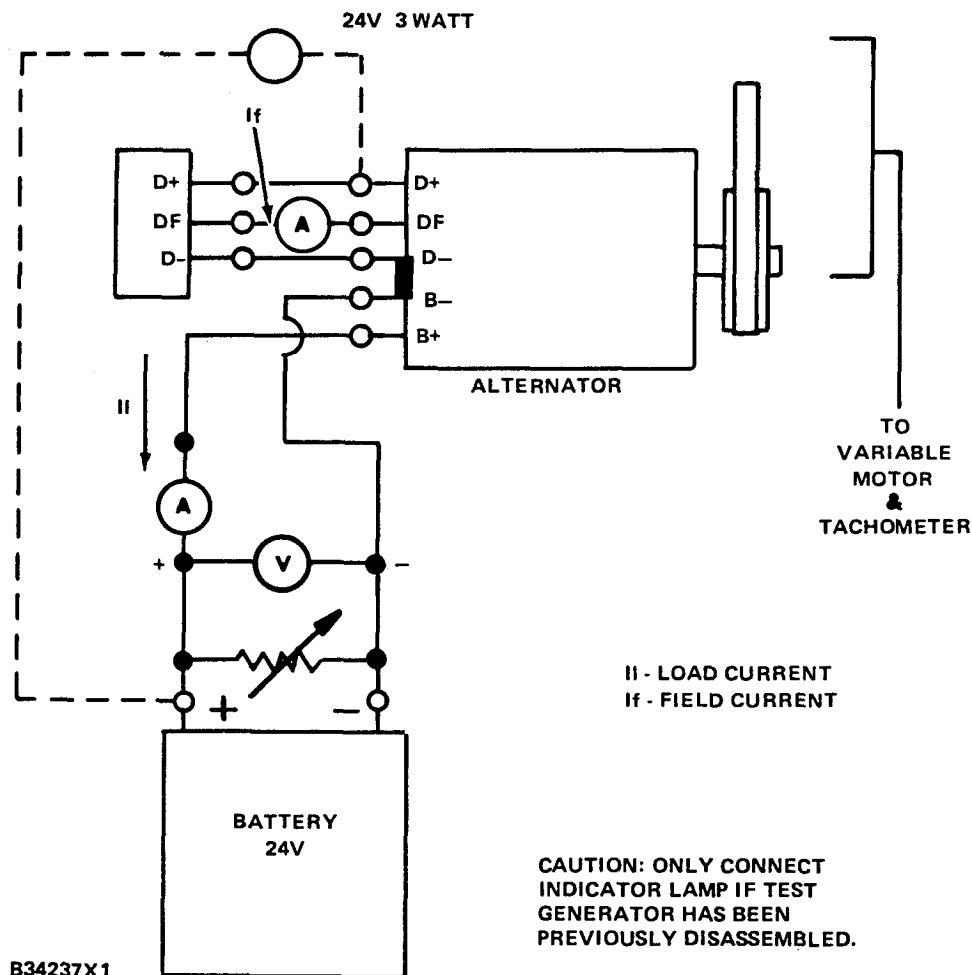

TEST BENCH SET-UP

ALTERNATOR

DISASSEMBLE ALTERNATOR

3T1888 (Delco-Remy)

1. Position alternator in a vise or similar clamping device.

CAUTION

Be careful not to overtighten alternator in vise, Damage is possible to alternator if vise is overtightened.

2. Retain alternator pulley and remove locknut (1, Figure A) and washer (2). Remove alternator pulley.

NOTE: Refer to page 5-12L for Figure A.

3. Remove fan (3).
4. Remove two bolts (4) and lockwashers (5). Pull end frame (6) and rotor (7) out of the alternator housing as an assembly.
5. Press rotor (7) out of end frame (6).
6. Remove shield (8).
7. Remove four screws (9) and retainer (10).
8. Remove gasket (11), collar (12), and seal (13).
9. Remove collar (14) and seal (15).
10. Press bearing (16) out of end frame (6).
11. Remove four screws (17), lockwashers (18) and regulator cover (19).
12. Remove two screws (20) and lockwashers (21). Remove five screws (22) and lockwashers (23).

13. Remove cover (24) and gasket (25).
14. Note how the leads are connected to the rectifier bridge (26). Disconnect three stator leads, six diode leads, and three regulator leads from rectifier bridge (26) by removing three nuts (27).
15. Remove nut (28), lockwasher (29) and field coil lead.
16. Remove screws (30), washers (31), lockwasher (32), and remaining field coil lead.
17. Remove regulator mounting screw (33) and regulator (34).
18. Remove alternator output terminal (35).
19. Remove screw (36) and lead assembly (37).
20. Remove screw (38), washers (39 and 40), insulator (41), and rectifier bridge (26).
21. Remove wiring grommet (42).
22. Remove three screws (43) and separate housing (44), stator (45), and field coil (46).
23. Remove cap (47).
24. If necessary, remove bearing (48) from housing and bearing race (49) from rotor.
25. If necessary, remove hinge bushing (50).
26. Terminals (51), grommet (52), and insulator (53) should not be removed unless visibly damaged.

NOTE: Refer to pages 5-12N & 5-120 for testing procedures.

ALTERNATOR

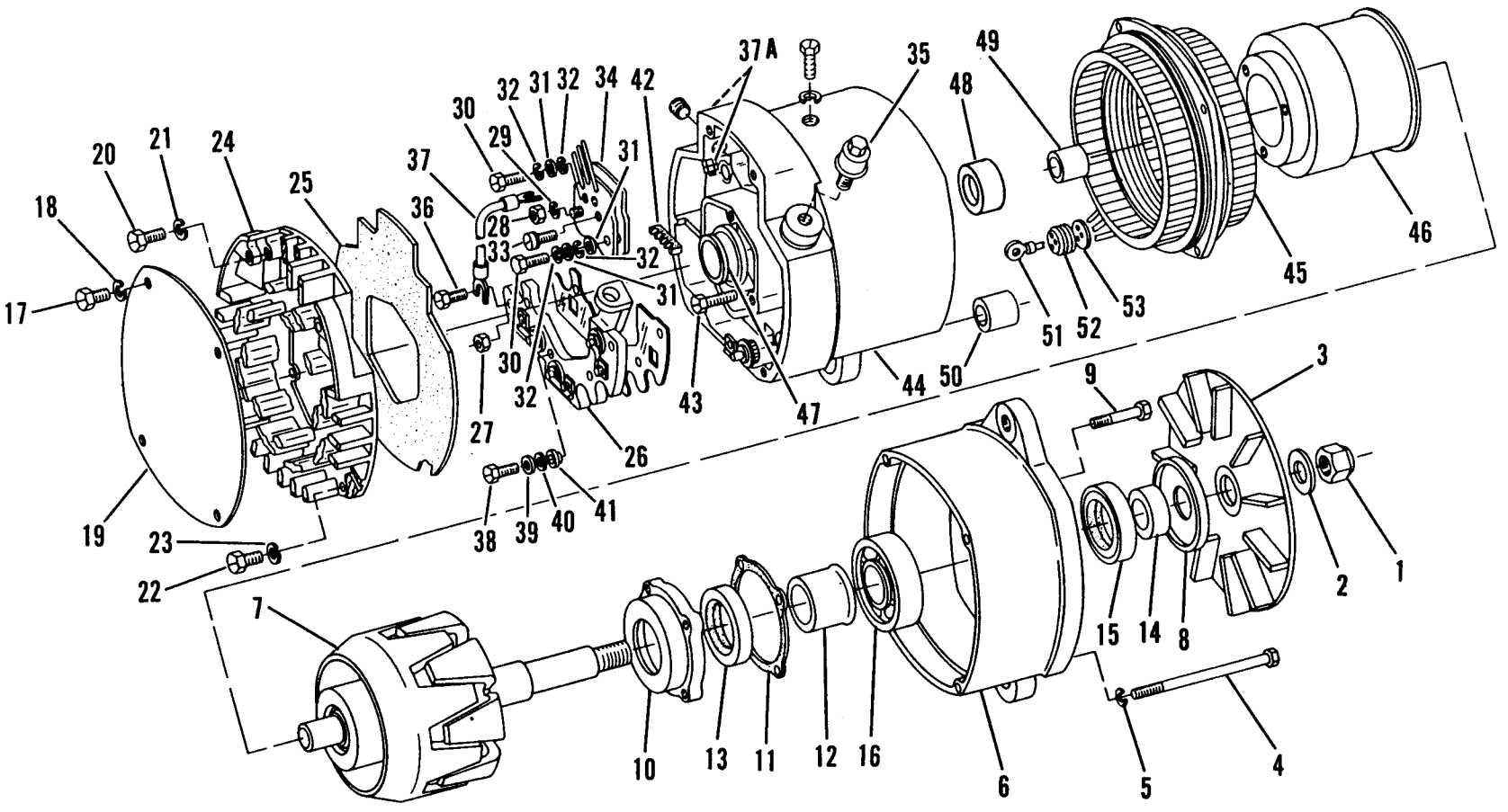
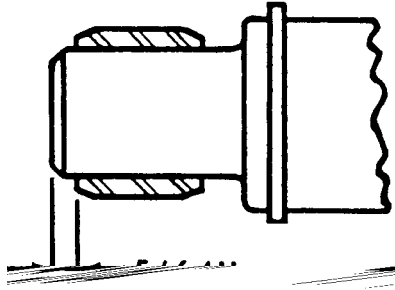

Figure A

ALTERNATOR

ASSEMBLE ALTERNATOR 3T1888 (Delco-Remy)

1. If removed, install hinge bushing (50).
2. If removed, install bearing race (49) to the dimension shown on the right.



INNER RACE LOCATION

3. If removed, install bearing (48) into housing (44) until bearing is flush with the inside of the housing.
4. Install cap (47).
5. Apply a light coating of silicone grease to grommet (52) and pull stator wiring into housing (44).
6. Attach field coil (46) and stator (45) to housing (44) with three screws (43).
7. Position wiring grommet (42) in stator housing.
8. Secure rectifier bridge (26) with insulator (41), washers (40 and 39), and screw (38).
9. Secure lead assembly (37) with screw (36).
10. Install alternator output terminal (35).
11. Secure regulator (34) with mounting screw (33).
12. Secure field coil leads with lockwashers (32), washers (31), screws (30), lockwasher (29), and nut (28).
13. Position the wiring on the rectifier bridge in this order:
 - (1) On each of the three rectifier studs, position two diode leads.
 - (2) Next, place a stator lead on each stud.
 - (3) Position the "R" terminal (37A) lead over one of the studs.

- (4) Secure wiring with three nuts (27).
14. Position gasket (25) and cover (24) on stator housing.
15. Install five lockwashers (23) and screws (22), Install two lockwashers (21) and screws (20).
16. Secure regulator cover (19) with lockwashers (18) and four screws (17).
17. Press bearing (16) into end frame (6) until bearing is flush with the inside surface of the end frame (6).
18. Install seal (15) and collar (14).
19. Install seal (13), collar (12).
20. Secure retainer (10) and gasket (11) with four screws (9).
21. Install shield (8).
22. Press rotor (7) into end frame (6).
23. Attach the end frame/rotor assembly to the stator housing with lockwashers (5) and bolts (4).
24. Install fan (3).
25. Position alternator in a vise or similar clamping device.

CAUTION

Be careful not to overtighten alternator in vise. Damage to the alternator is possible if the vise is overtightened.

26. Place alternator pulley on alternator and secure with washer (2) and locknut (1).
27. The alternator rotor usually retains magnetism to provide voltage buildup when the engine is started. However, after disassembly or servicing it may be necessary to reestablish the magnetism. Perform the following procedures to demagnetize the rotor.
 - (1) Install the alternator.
 - (2) Momentarily connect a jumper lead from the battery positive post to the "R" terminal (37A).

ENGINE

DELCO REMY ALTERNATOR TESTING

Tools Needed:

Multimeter

FIELD COIL TESTS

1. To check for grounds, connect a test lamp, or an ohmmeter, to one field coil lead and to the end frame as shown. If the lamp lights or if the ohmmeter reading is low (less than 10K), the field coil is grounded.

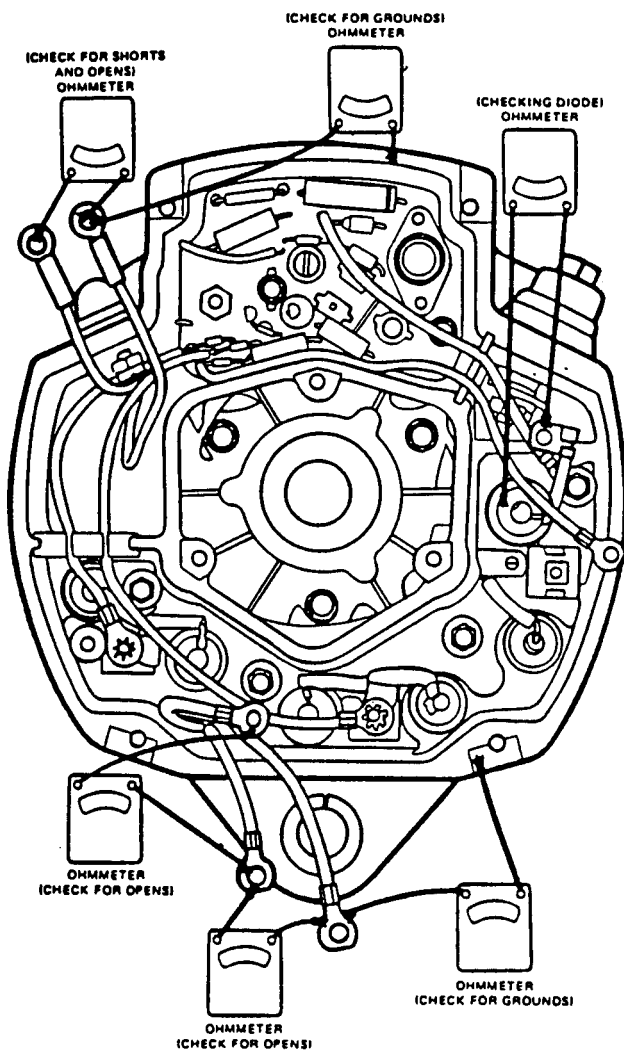

2. To check for opens, connect a test lamp, or an ohmmeter to the field coil leads as shown. If the lamp fails to light, or if the ohmmeter reading is high (infinite), the field coil is open.

3. The windings can be checked for shorted circuits by connecting a battery and ammeter in series with the field coil. The specified field current is 2.5 to 2.9A at 80°F. An ammeter reading above the specified value indicates shorted windings.

DIODE TESTS

1. Check each of the six diodes by removing each diode lead from the stud and connecting an ohmmeter (set at lowest range) to the diode lead and case. Reverse the ohmmeter leads to the diode lead and case.

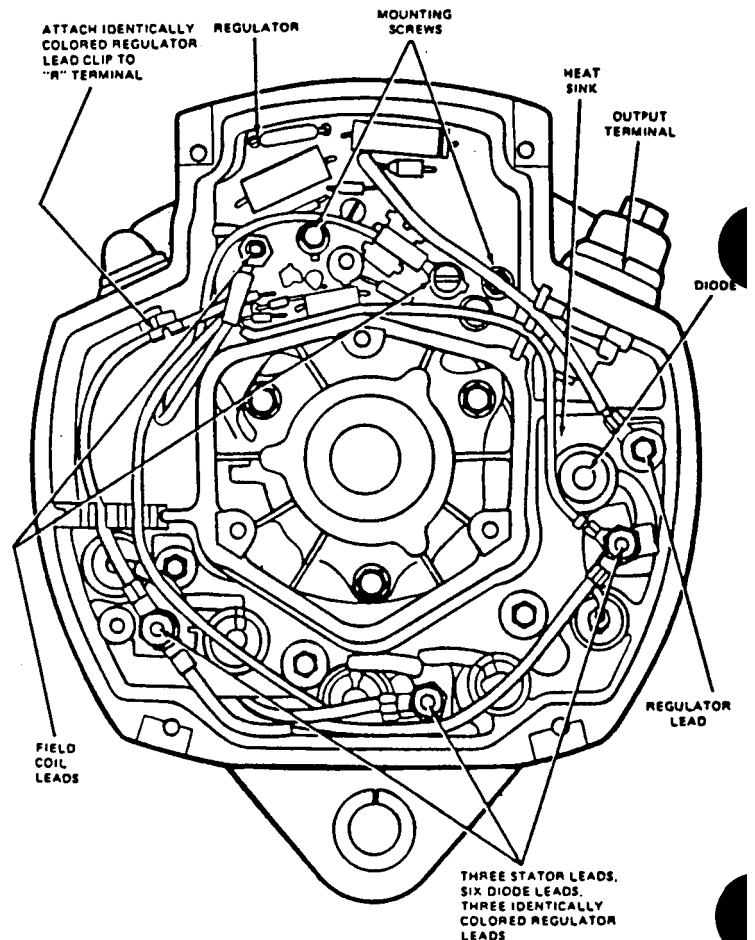

2. If both readings are the same, replace the regulator assembly. A good diode will have one high and one low reading.

Disassembly AND ASSEMBLY

ALTERNATOR TESTING**STATOR TESTS**

1. The stator windings may be checked with a 110 volt test lamp or an ohmmeter. If the lamp lights or if the meter reading is low when connected from any stator lead to the frame, the windings are grounded.
2. If the lamp fails to light, or if the meter reading is high (infinite) when successively connected between each pair of stator leads, the windings are open.
3. A short circuit in the stator windings is difficult to locate without laboratory test equipment due to the low resistance of the windings. However, if all other electrical tests are normal and the alternator fails to supply the rated output, shorted stator windings are indicated.
4. If the stator windings are found to be faulty, replace the regulator assembly.

ENGINE

STARTING MOTOR

DISASSEMBLE STARTING MOTOR 3T4584

Tools Needed		A	B
1P510	Driver Group	1	
1P1855	Retaining Ring Pliers		1

1. Disconnect wire assembly (1, Figure A) from solenoid assembly (2).

NOTE: Refer to page 5-12Q for Figure A.

2. Remove nuts (3), lockwashers (4), and terminal connector (5) from starter motor housing.
3. Remove four screws (6, Figure B), nuts (7), washers (8) and pull terminal assembly (9) far enough away from the solenoid assembly (2) to access the three leads connected to the solenoid terminal assembly (9).

NOTE: Refer to page 5-12R for Figure B.

4. Disconnect three leads from terminal assembly (9). If necessary, remove nuts, washers and lockwashers (10, Figure B), insulator (11), and spring (12) from solenoid.
5. Remove contact assembly (13) and bushing (14) from solenoid. If necessary, remove terminals (15) and terminal nuts (16).
6. Remove retainer (17, Figure C) and remove four bolts (18, Figure A), Remove solenoid assembly (2).

NOTE: Refer to page 5-12S for Figure C.

7. Remove plug (19, Figure C) and gasket (20). Remove nut (21) and solenoid plunger assembly.

8. If necessary, remove retaining ring (22) spring (23), boot (24), retainer (25), and washer (26) from plunger (27).
9. Remove three plugs (28, Figure A) and gaskets (29). Disconnect three field winding leads from brush plate assembly (30).
10. Scribe a line across the starter motor housing, shift lever housing, drive housing, and end frame. The line will be used for alignment during reassembly.
11. Remove nut (31), washers (32), and negative (-) wire assembly (33).
12. Remove six bolts (34), washers (35) and pull end frame assembly (36) back far enough to access the brushes.
13. Pull each brush spring up and place springs along sides of each brush. This will release the brush pressure against the commutator.
14. Remove end frame assembly (36) and thrust washer (37). Remove bushing (38) from end frame assembly with tool A.
15. Remove screws (39) and brushes (40). Remove negative terminal nut (41), lockwasher (42), washer (43), and insulator (44). Bushing (45) is not removed unless visibly damaged.
16. Remove three screws (46), brush plate (47), insulator (48), washers (49), and gasket (50) from end frame assembly (36).
17. Remove screws (51), washers (52), brush holders (53), plates (54), plate (55), and insulator (56).
18. Remove six screws (57, Figure C), and drive housing assembly (58).
19. Remove bushing (59) from drive housing with tool A.
20. Remove armature assembly (60, Figure A).

STARTING MOTOR

DISASSEMBLY AND ASSEMBLY

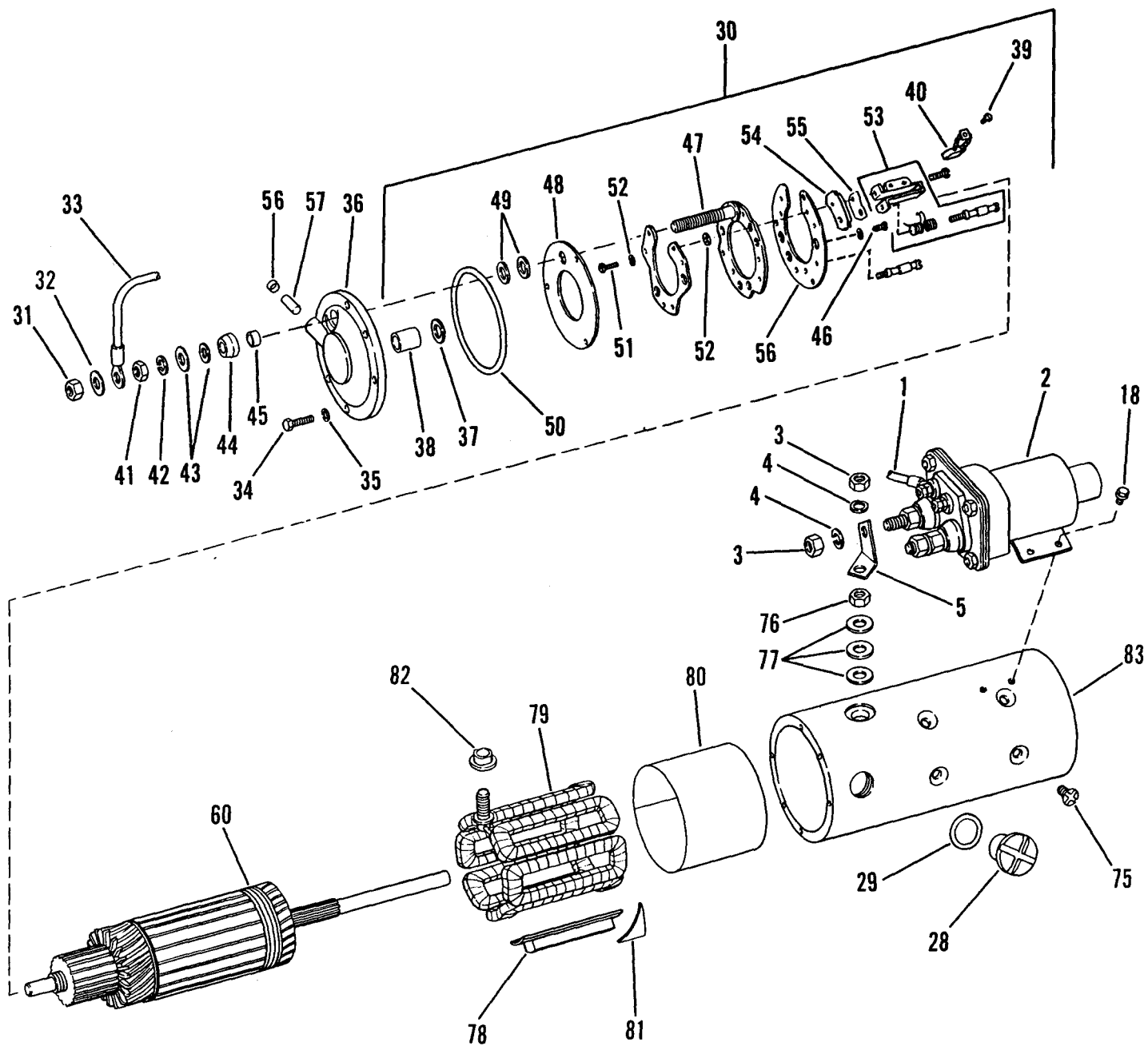

5-12q

Figure A. 3T4584 Starting Motor – Part 1 of 3

STARTING MOTOR

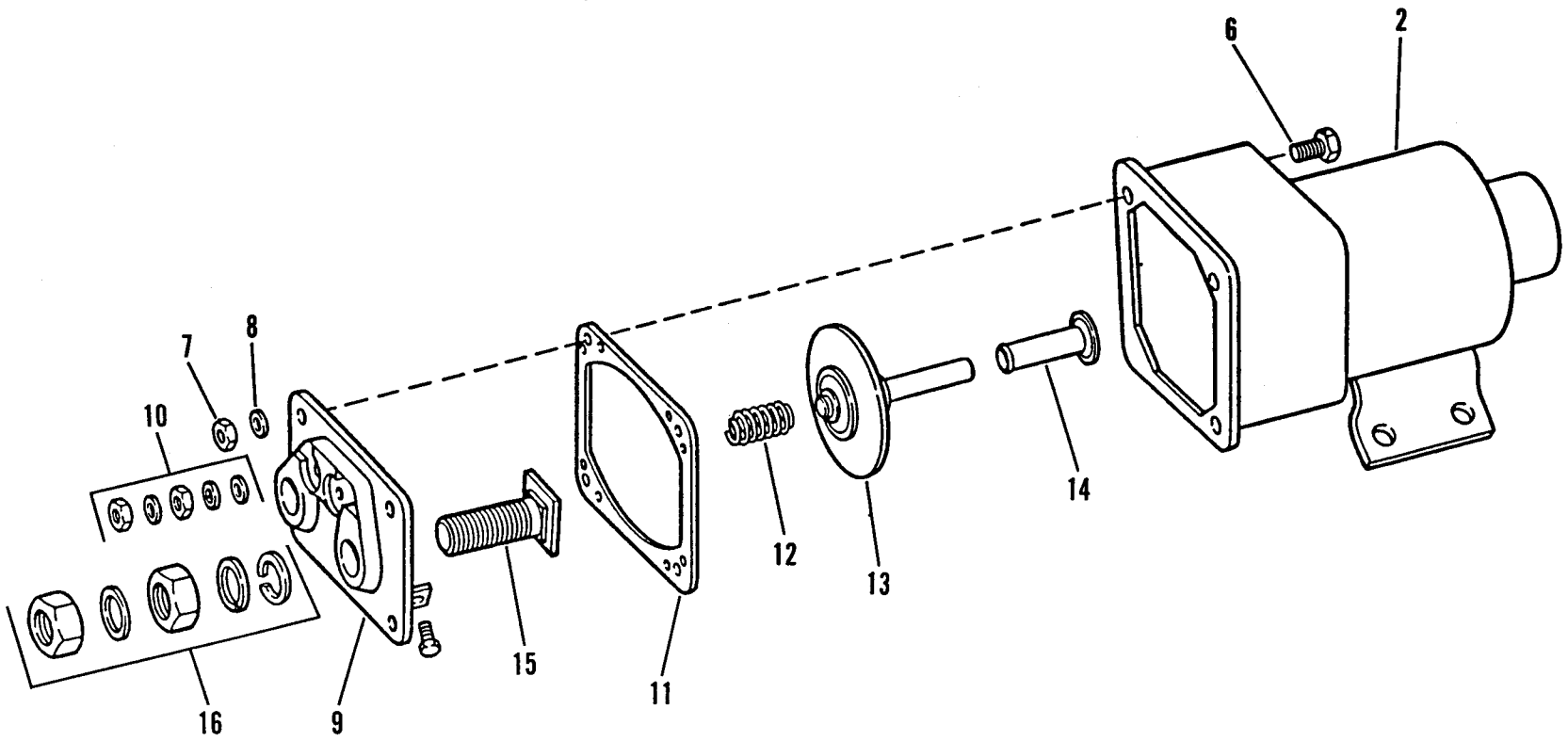
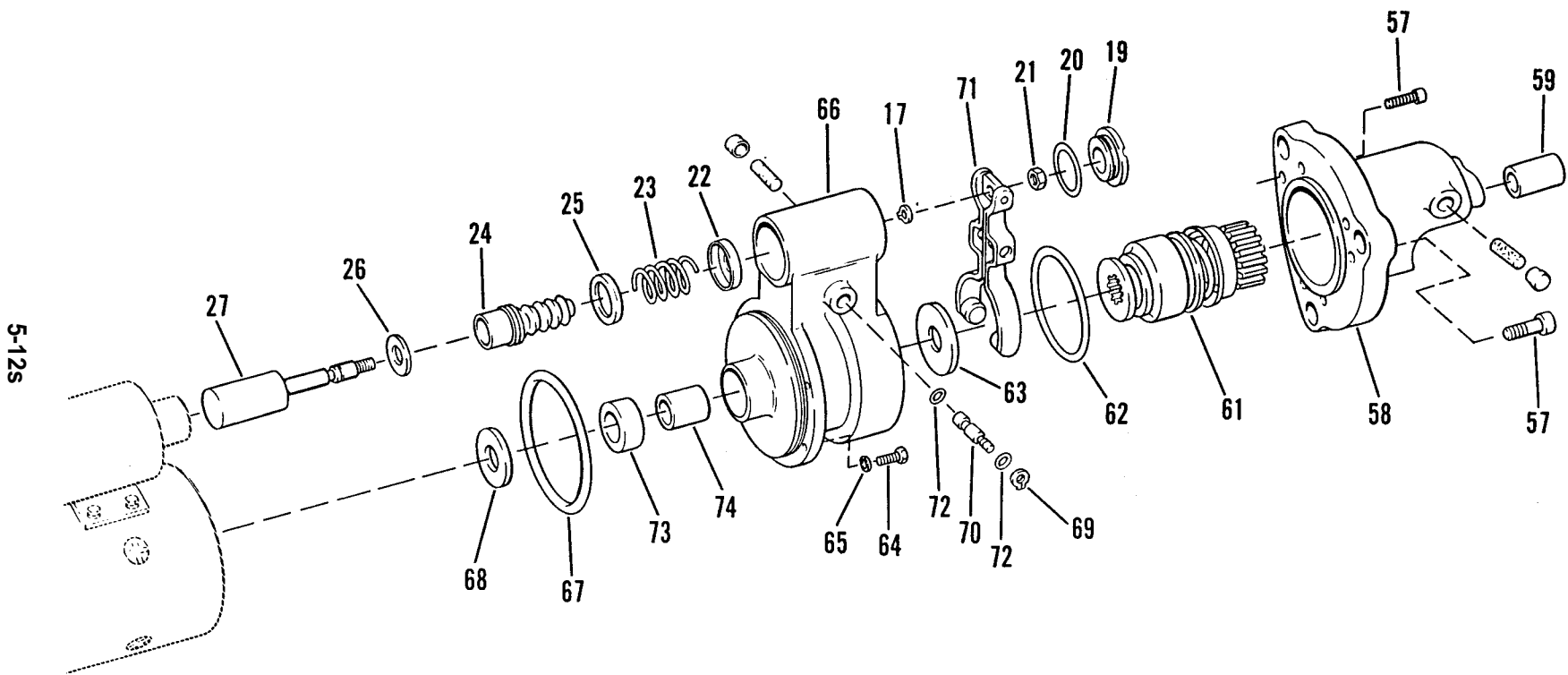

Figure B. 3T4584 Starting Motor – Part 2 of 3

STARTING MOTOR



5-12s

Figure C. 3T4584 Starting Motor – Part 3 of 3

ENGINE

STARTING MOTOR

21. Remove drive assembly (61, Figure C) and seal (62). Spacer (63) will fall out of housing when armature and pinion drive assemblies are removed.
22. Remove seven bolts (64), washers (65), and shift lever housing assembly (66). Remove seal (67) and washer (68).
23. Remove snap ring (69) with tool B. Remove shaft (70) and shift lever (71). If necessary, remove seals (72) from shaft (70). Note that one seal (72) is larger than the other. Do not interchange the two seals.
24. Remove seal (73) and bushing (74) with tool A.
25. Remove twelve screws (75, Figure A), terminal nuts (76), washers (77), pole shoes (78), field coil (79), insulator (80), three insulators (81) and terminal insulator (82).

NOTE: It may be necessary to use an impact driver to remove screws (75).

ASSEMBLE STARTING MOTOR 3T4584

Tools Needed		A	B
1P510	Driver Group	1	
1P1855	Retaining Ring Pliers		1

1. Apply clean SAE 20W lubricating oil on all busings, seals, and oil wicks.
2. Position field coil (79, Figure A) and pole shoes (78) with insulators (80), (81), and (82) in starter motor housing (83).
3. Install twelve screws (75).
4. Install terminal washers (77) and nut (76). Tighten nut to a torque of 20 to 22 lb. ft. (27 to 33 N.m).
5. Install bushing (74, Figure C) and seal (73) in the shift lever housing using tool A.
6. Install seals (72) on shaft (70). Position shift lever (71) in the shift lever housing. Note that one seal (72) is larger than the other. Do not interchange the two seals.

7. Install shaft (70) and snap ring (69) using tool B.
8. Install seal (67) on shift lever housing (66).
9. Place shift lever housing (66) on starter motor housing (83). Aline marks made during disassembly and install and tighten seven bolts (64) with washers (65). Tighten bolts (64) to a torque of 84 to 132 lb. in. (9.5 to 14.9 N-m).
10. Apply multipurpose grease on armature (60, Figure A) where the armature contacts the armature bushings. Do not apply grease to the armature windings or commutator.
11. Place pinion drive assembly (61) in position on the fork of shift lever (71).
12. Place washer (68) on armature shaft and install armature in starter motor and shift lever housings. Place spacer (63) on armature shaft and position drive assembly (61) on armature shaft.
13. Install bushing (59, Figure C) into drive housing (58) with tool A.
14. Place drive housing (58) on shift lever housing (65). Aline marks made during disassembly. Install six screws (57). Tighten screws (57) to a torque of 13 to 17 lb. ft. (17 to 23 N-m).
15. Position insulator (56, Figure A), plate (55), plates (54) and brush holders (53) on the brush plate assembly (47).
16. Install screws (51) and washers (52).
17. Install bushing (38) in end frame assembly with tool A.
18. Install seal (50) on end frame. Position insulator (56) on brush plate assembly (47).
19. Position washers (49) on negative brush plate terminal.
20. Position brush plate (47) on end frame and secure with three screws (46).

STARTING MOTOR

21. Install insulator (44), lockwasher (42), and nut (41) on negative terminal. Tighten nut to a torque of 17 to 35 lb. in. (1.9 to 3.9 N·m).
22. Install brushes (40), and secure with screws (39). Position brush springs along side of brushes. Tighten brush lead screws (34) to a torque of 17 to 35 lb. in. (1.9 to 3.9 N·m).
23. Place washer (37) on armature assembly.
24. Position end frame assembly (36) over the armature commutator.
25. Position end frame assembly (36) against the starter motor housing. Make sure that the marks made during disassembly are aligned.
26. Install six bolts (34) and washers (35) which secure housings and tighten bolts to a torque of 84 to 132 lb. in. (9.5 to 14.9 N·m).
27. Install negative wire assembly (33) and secure with nut (31) and washer (32).
28. Connect field winding leads to brush plate assembly (30). Tighten brush plate screws to a torque of 17 to 35 lb. in. (1.9 to 3.9 N·m).
29. Install three access plugs (28) with seals (29).
30. Install washer (26, Figure C), retainer (25), boot (24), spring (23), and retainer (22) on plunger (27) shaft.
31. Position plunger assembly (27) into shift lever housing (65) and shift lever (70). Install retainer (17) and nut (21). Tighten nut (21) finger tight, the plunger assembly will be adjusted after the starter is completely assembled.
32. Position solenoid (2, Figure A) over plunger assembly.
33. Install bolts (18) and tighten bolts to a torque of 84 to 132 lb. in. (9.5 to 14.9 N·m).
34. Install contact assembly (13, Figure B) and bushing (14). Install insulator (11), terminals (15), terminal assembly (9), and spring (12).
35. Install nuts, lockwashers and washers (10) and tighten nuts to a torque of 17.8 to 22.2 lb. in. (2.0 to 2.5 N·m).
36. Connect solenoid leads to terminal assembly (9).
37. Install and tighten bolts (6), washers (8), and nuts (7) which secure contact assembly to solenoid. Tighten nuts to a torque of 17.8 to 22.2 lb. in. (2.0 to 2.5 N·m).
38. Install and tighten terminal nuts and washers (16) to a torque of 20 to 24 lb. ft. (27 to 33 N·m).
39. Check the starter pinion clearance between the end of the pinion and the end of the drive housing (58) with starter solenoid engaged. Refer to starter motor specifications in Chapter 2. If clearance is not within specifications, remove plug (19) and gasket (20). Adjust nut (21) as required, to achieve proper pinion clearance. Install plug (19) with gasket (20).

NOTE: Refer to Chapter 4 for starter testing procedures.

ENGINE

AIR COMPRESSOR

REMOVE AIR COMPRESSOR

1065-11

WARNING

Do not disconnect the air lines until the air pressure in the system is at zero.

NOTE: Port locations are different between models 950BS/950BNS and 950BSCE/950BNSE. Procedures are the same for both.

1. Drain the coolant from the radiator.
2. Remove tube assemblies (1), (2) and (3) from the engine.
3. Disconnect air line (5) from the air compressor.
4. Disconnect air line (6) from the air compressor governor.
5. Disconnect oil line (4) from the air compressor.
6. Remove fitting (7) from air compressor (8).
7. Remove the bolts and air compressor (8) from the timing gear cover.

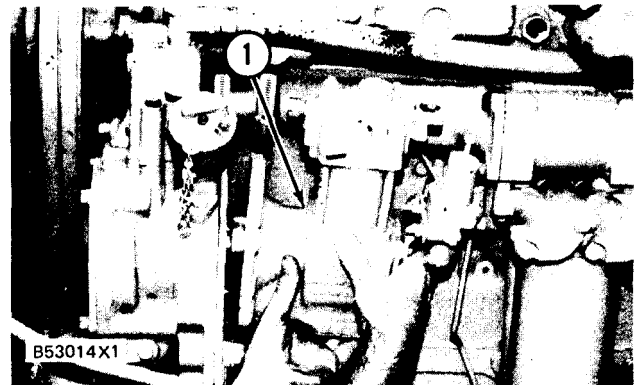
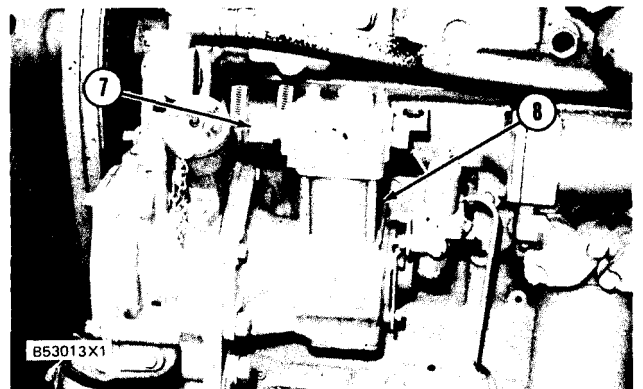
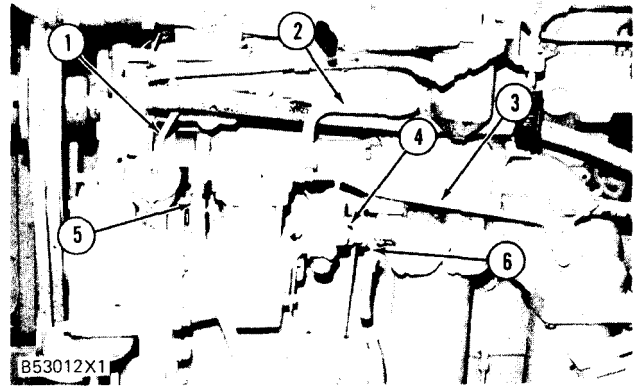

INSTALL AIR COMPRESSOR

1. Make sure all gasket surfaces are clean and free of dirt.
2. Put the gasket and air compressor (1) in position on the timing gear cover as shown and install the nuts and bolts.
3. Install fitting (6) on the air compressor.
4. Install tube assemblies (2), (3) and (4) as shown.
5. Connect air line (7) to the air compressor, air line (8) to the compressor governor and oil line (5) to the air compressor.
6. Fill the radiator to the correct level with coolant.

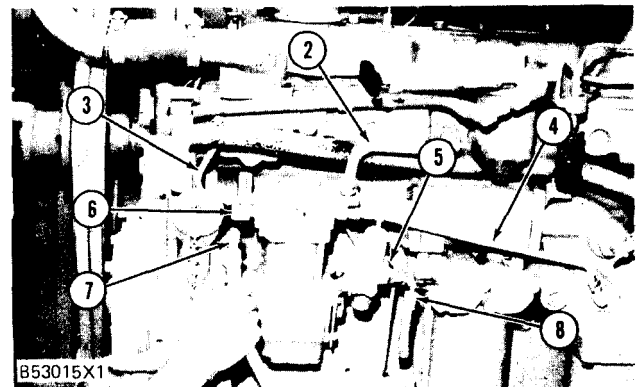

AIR COMPRESSOR HEAD ASSEMBLY

Models 950BNS and 950BS

REMOVE HEAD ASSEMBLY

11-1065

1. Loosen two set screws (1) and cover (2).
2. Put alignment marks on head assembly (3) and on cylinder (5) and also on the cylinder and on crankcase (7) so parts can be put in correct location when they are assembled.
3. Disconnect air line (4) and remove two bolts (8) and governor assembly (6).
4. Remove four nuts (9) and remove head assembly (3).

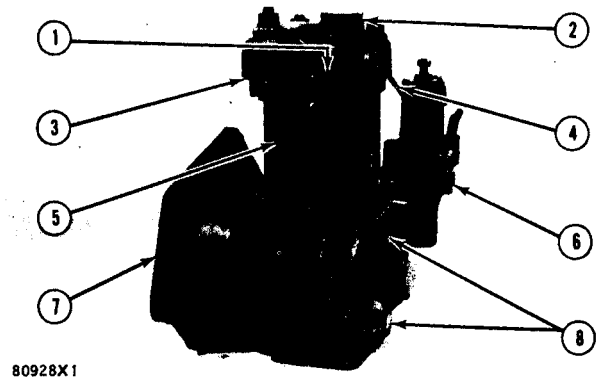

80928X1

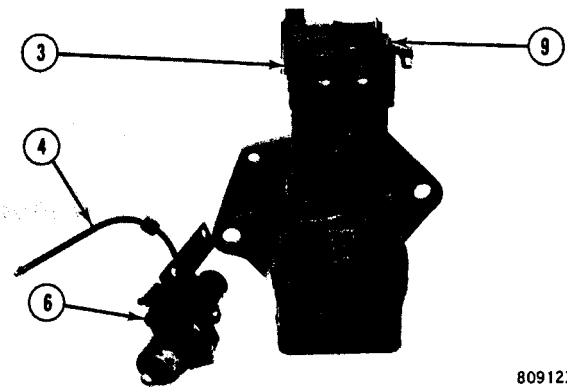

80912X1

NOTE: If needed, hit head assembly (3) with a soft hammer and then remove the head assembly.

INSTALL HEAD ASSEMBLY

12-1065

1. Install new gasket (4) on cylinder (2).
2. Install head assembly (1) on cylinder (2).
3. Put alignment marks on the cylinder and head assembly together and tighten four nuts (8). Torque for nuts is 14 ± 3 lb. ft (1.9 ± 0.4 mkg).
4. Install governor assembly (6) on end cover (5) and tighten bolts (10). Torque for bolts is 10 lb. ft. (1.38 mkg). Connect air line (3) to head assembly (1).
5. Tighten cover (7). Torque for cover is 60 lb. ft. (8.3 mkg).
6. Tighten two set screws (9), Torque for set screws is 50 to 96 lb.in. (57.6 to 110.7 cm kg).

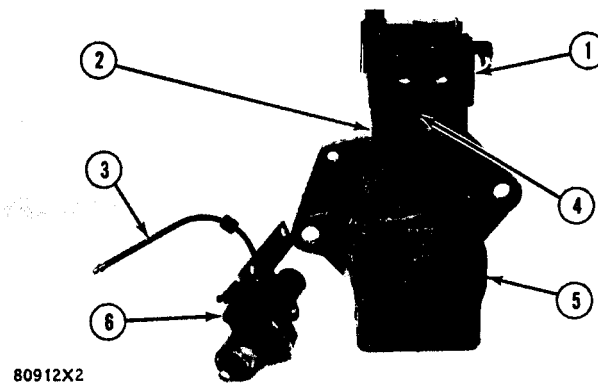

80912X2

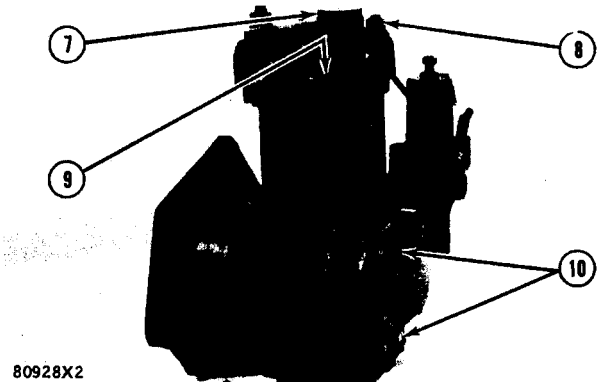

80928X2

AIR COMPRESSOR HEAD ASSEMBLY

Models 950 BNS and 950BS

DISASSEMBLE AND ASSEMBLE 17-1065

start by:

a) remove head assembly

1. Remove cover (7), unloader valve (1) and spring (2) from top half (3) of head and clean the unloader valve.
2. Remove two set screws from top half (3) and hit either top half (3) or bottom half (4) with a soft hammer to separate the head.
3. Remove and clean exhaust valve (5) and spring (6).
4. Remove and clean inlet valve (8) and spring.
5. Clean all of the passages in both top half (3) and bottom half (4).
6. Place a new gasket (10), spring (6) and exhaust valve (5) on bottom half (4) of the head.
7. Place inlet valve (8) and spring (9) on top half (3) of the head.
8. Carefully put half (3) on half (4). Inlet valve (8) can be moved to the correct location with a rod through the opening for the unloader valve.
9. Install the two set screws to hold the top half (3) and the bottom half (4) of the head together.
10. Install unloader valve (1), spring (2) and cover (7) in the head.

end by:

a) install head assembly

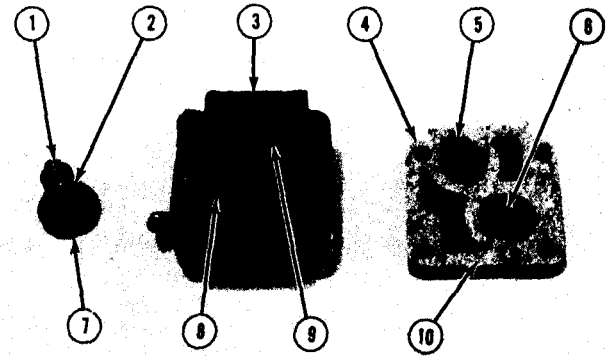

80923X1

AIR COMPRESSOR PISTON AND ROD

Models 950BNS and 950BS

PISTON AND ROD REMOVAL

11-1065

start by:

a) remove head assembly

1. Remove cylinder (1) and gasket (2).

2. Remove bolts (3) and end cover (4).

3. Remove four bolts and cover (6).

4. Put marks on rod cap (9) and rod (10) so rod and rod cap can be installed on crankshaft (11) in the same location as they were removed.

5. Bend lock (7) and remove bolts (8) and rod cap (9). Remove rod (10) and piston (12) from crankcase (5).

6. Mark piston (12) so it can be installed on rod (10) in the same location as it was removed.

7. Remove pin lock (13) and push pin (14) out of piston (12) and rod (10).

8. Clean all parts.

9. Remove piston rings and clean the ring grooves in piston (12) with a piece of hard wood.

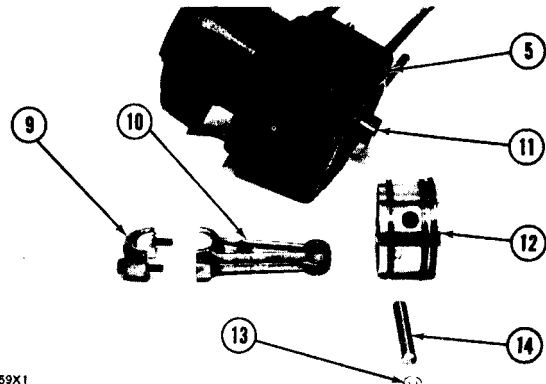
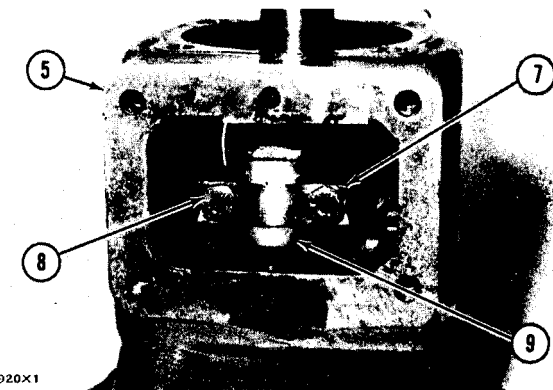
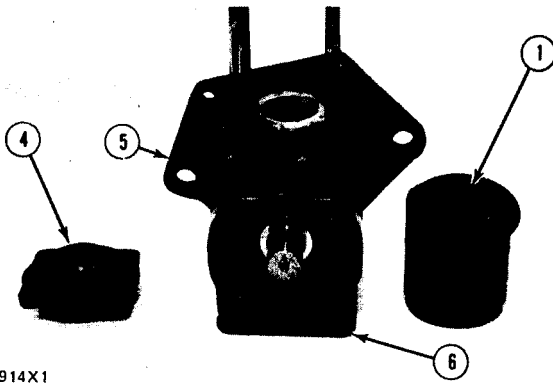
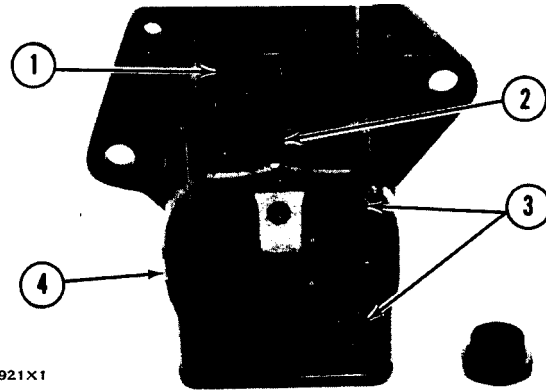

AIR COMPRESSOR PISTON AND ROD

Models 950BNS and 950BS

INSTALL PISTON AND ROD

12-1065

1. The gap for oil ring (1) and the gap for rings (2) is measured with the rings near the bottom in cylinder (12). The gap for each ring is .003 to .009 in. (0.08 to 0.23 mm).

2. Install rings (1) and (2) on piston (3). The gap for each ring must not be near the piston pin bore and each gap must be approximately 120° from the gap in the next ring.

3. Install pin (4) in piston (3) and rod (6). Install pin lock (7). The mark put on the piston shows if the location of the piston on the rod is correct.

4. Put rod (6) and piston (3) into crankcase (11). Install rod cap (5). The marks put on the rod cap and rod show the correct location of the rod in crankcase (11).

5. Tighten bolts (9) to a torque of 35 to 40 lb.in. (40.6 to 46.1 cm.kg). Bend lock (10) over bolt heads.

6. Put a new gasket on both end cover (13) and cover (15) and install the covers and gaskets on crankcase (11).

7. Put a new gasket (14) on cylinder (12) and put the gasket and cylinder on crankcase (11). The marks put on the cylinder and crankcase, before the head assembly was removed, must be together.

end by:

a) install head assembly

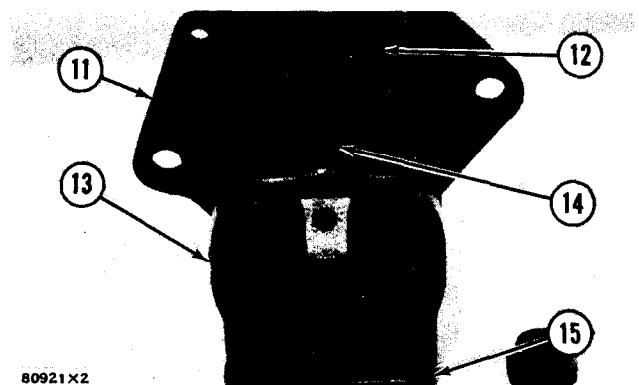
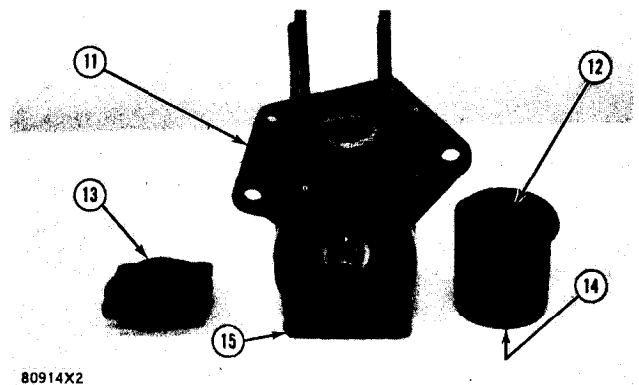
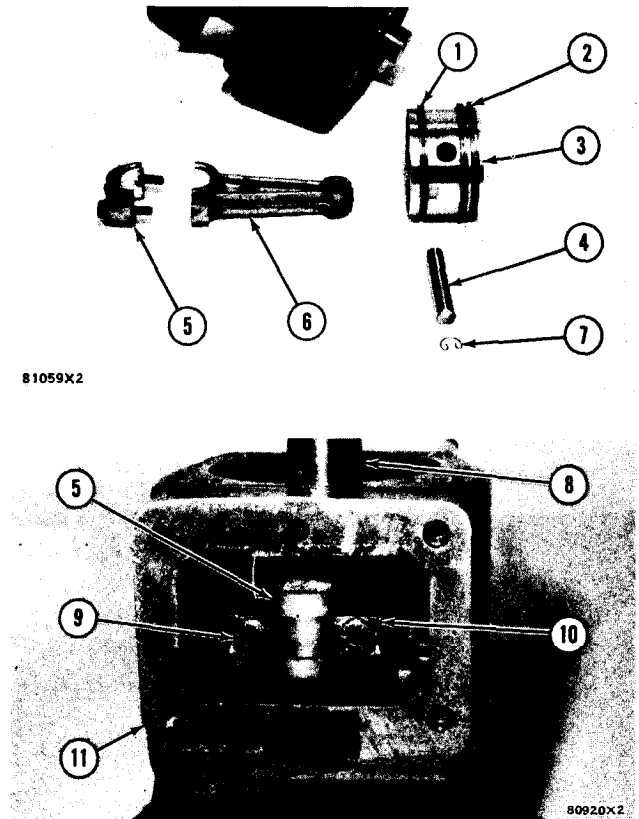

AIR COMPRESSOR CRANKSHAFT

Models 950BNS and 950BS

REMOVE CRANKSHAFT

11-1065

start by:

- a) remove head assembly
- b) remove piston and rod

1. A press (1) can be used to remove crankshaft (3) from crankcase (4).

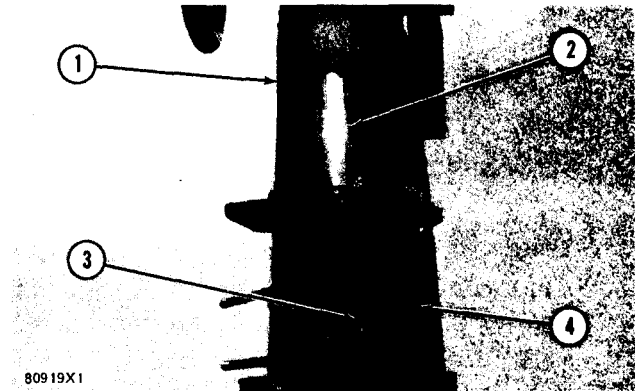

2. Put a pipe (2), with a bore larger than 1.03 in. (26.2 mm) and a diameter of approximately 2 in. (50.8 mm) with an approximate length of 6 in. (152.4 mm), over the end of crankshaft (3) and on bearing (5).

3. Push crankshaft (3) and bearing (5) out of crankcase (4) as a unit.

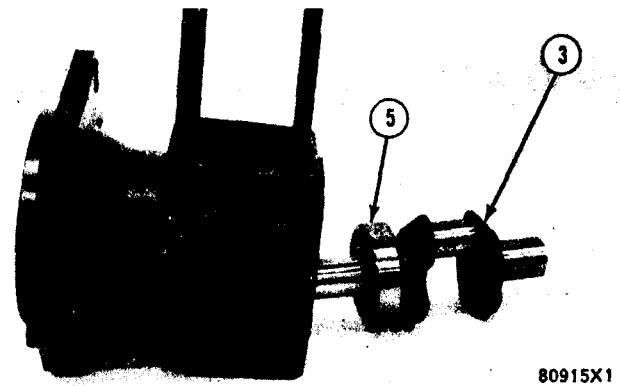

4. Remove bearing (5).

INSTALL CRANKSHAFT

12-1065

1. Heat the crankshaft ball bearing in oil to a temperature of not over 350°F (175°C) and put the bearing on crankshaft (3).

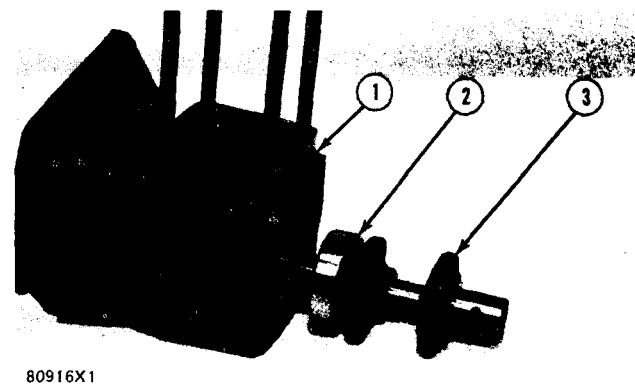

2. Put the bearing and crankshaft (3) into crankcase (1) with the crankcase resting on the large flange end.

3. Outer race (2) of the bearing is pushed into the crankcase with a soft metal rod put at many locations on outer race (2) while hitting the rod with a hammer.

end by:

- a) installing piston and rod
- b) installing head assembly

ENGINE

HEAD ASSEMBLY

REMOVE HEAD ASSEMBLY

start by:

a) remove air compressor

1. Remove two bolts and washers (1).
2. Remove governor (2) and gasket (3).
3. Remove two bolts and washers (4); adapter (5), and gasket (6).
4. Remove four bolts (7) and remove head assembly (8).

NOTE: It may be necessary to tap the head assembly with a soft hammer to break the gasket seal.

5. Remove and discard gasket (9).

INSTALL HEAD ASSEMBLY

NOTE: Make sure all of the old gasket material is removed from the mating surfaces of the head and crankcase.

NOTE: Gaskets (3, 6, and 9) are also available with Repair Kit 7C0569 (Refer to Head Assembly, Disassemble and Assemble).

1. Install new gasket (9).
2. Install head assembly (8) and tighten four bolts (7) in a cross-pattern to 175-225 lb. in. (202-260 kg.cm).
3. Install new gasket (6), adapter (5), and bolts and washers (4).
4. Install new gasket (3).
5. Install governor (2) with bolts and washers (1).

end by:

a) install air compressor

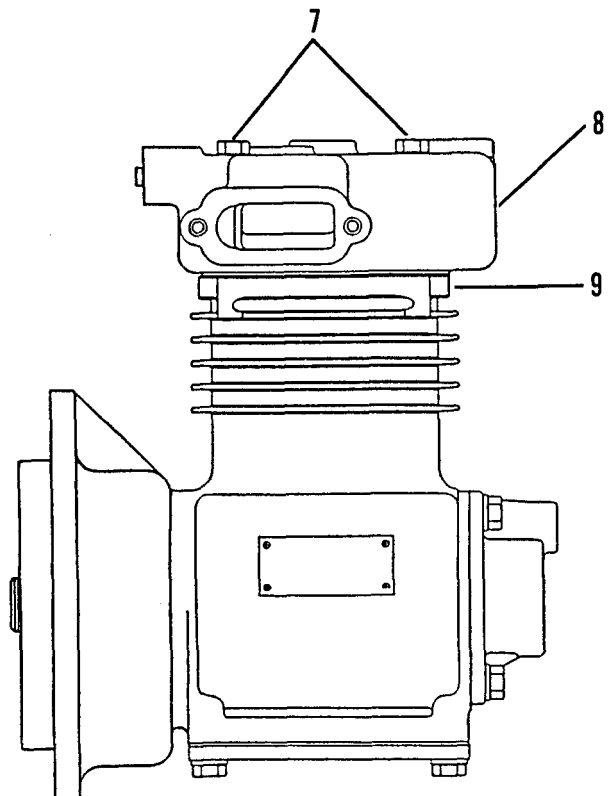
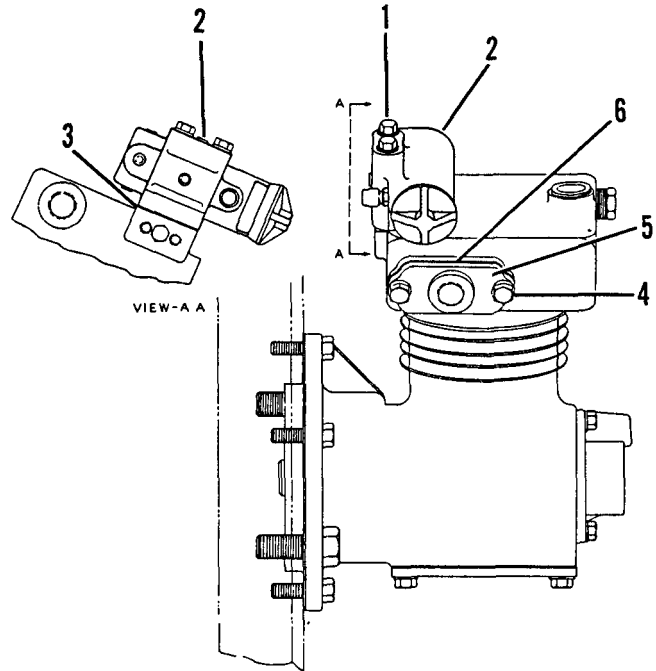

ENGINE

HEAD ASSEMBLY

DISASSEMBLE AND ASSEMBLE

start by:
 a) remove head assembly

NOTE: Replacement parts are available only in kits.

REPLACEMENT PARTS

Item	Part No.	Description
1,2	7C0571	Unloader Kit
1-11	7C0569	Major Repair Kit

1. Remove unloader stop assembly (1) and discard.
2. Remove piston assembly (2) and discard.
3. Use a spanner wrench to remove inlet valve stop (3).
4. Remove and discard inlet valve spring (4), inlet valve (5), valve seat (6), unloader gasket (7), and unloader spring (8).
5. Remove discharge valve seat (9) using a 9/16" Allen wrench.
6. Remove and discard discharge valve (10) and spring (11).
7. Remove all carbon deposits, rust, and scale from all cavities in the cylinder head. Scrape head assembly and crankcase mating surfaces taking care not to allow foreign material to fall into the cylinder.
8. Inspect the inlet valve stop (3) for excessive wear, nicks, and scratches. If necessary, "dress" surfaces with a lapping stone to remove nicks and scratches.
9. If inlet valve stop is not salvageable, replace it with a new part.

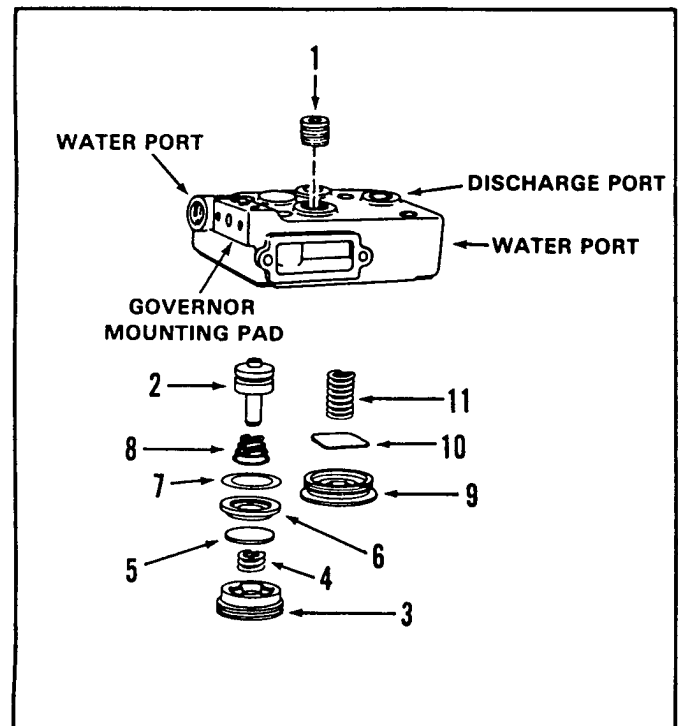

HEAD ASSEMBLY

10. Install unloader stop assembly (1). Tighten to 175-225 lb. in. (202-260 kg.cm) torque.
11. Install unloader piston assembly (2), short stem first.
12. Install unloader spring (8), small end first, onto the long stem of the unloader piston assembly (2).
13. Install unloader gasket (7) over the unloader spring and rest it on the shoulder of the hole in the unloader cavity.
14. Install valve seat (6) on top of the unloader gasket, bevel side of valve seat up.
15. Install inlet valve (5) on valve seat.
16. Install inlet valve spring (4) on inlet valve.
17. Install inlet valve stop (3). Tighten to 840-1080 lb. in. (970-1247 kg.cm) torque.
18. Install discharge valve spring (11).
19. Install discharge valve (10) on top of discharge spring, and retain with valve seat (9).
20. Using a 9/16" Allen wrench, tighten valve seat (9) to 840-1080 lb. in. (970-1247 kg.cm) torque.

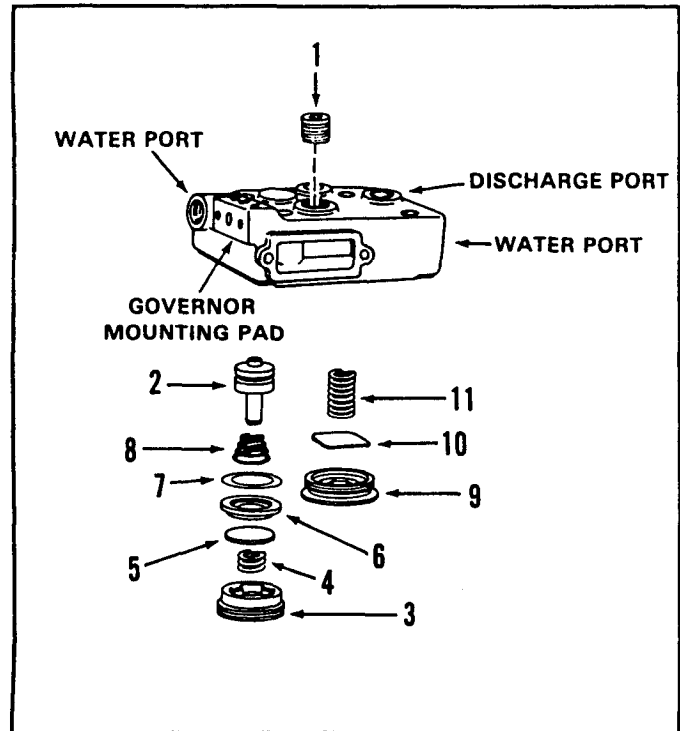

PISTON AND ROD

PISTON AND ROD REMOVAL

start by:

a) remove head assembly

1. Remove four bolts and lockwashers (1). Remove cover (2) and seal (3).
2. Remove four bolts and lockwashers (4). Remove cover (5) and gasket (6).
3. Put matching identification marks on the rod cap (7) and piston rod (8) to ensure correct assembly.
4. Remove bolts (9) and rod cap (7), then remove piston and rod (8) from the crankcase.
5. Put matching identification marks on the piston and the rod to ensure correct assembly.
6. Remove retaining ring from wrist pin (10) and push pin from piston and rod.
7. Clean all parts.
8. Remove piston rings (11) and oil rings (12). Clean ring grooves in piston (13) with a piece of hard wood.

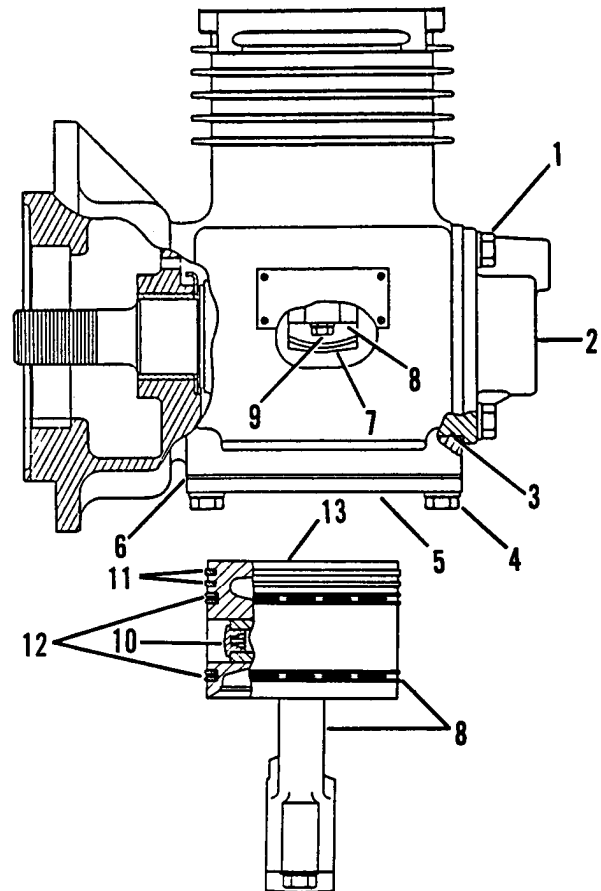

INSTALL PISTON AND ROD

1. Inspect piston for scoring, cracks, or enlarged ring grooves. Replace piston if any of these conditions exist.
2. Check wrist pin installation. If pin can be inserted through the piston and rod with only slight pressure, fit is acceptable. If pin is a loose fit, the piston and rod assembly must be replaced.
3. Install piston rings (1) and oil rings (2). The gap for each ring must not be near the piston pin bore, and each gap must be approximately 1200 from the gap in the next ring.

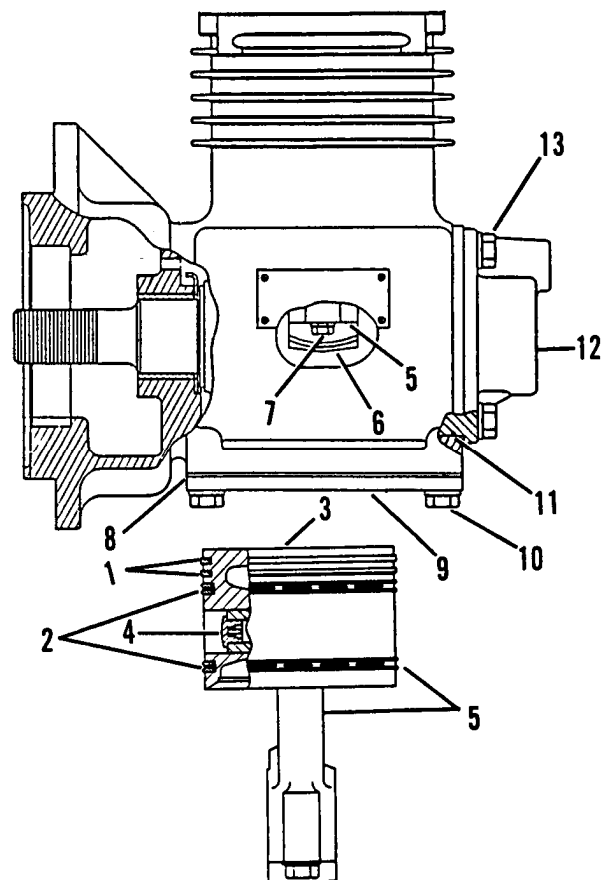

PISTON AND ROD

4. Measure clearance between grooves and piston rings (1), and between grooves and oil rings (2). Clearance must be 0.004 to 0.012 in. (0.10 to 0.30 mm).
5. Assemble piston (3) to rod. Be sure identification matching marks made during disassembly are aligned.
6. Install wrist pin (4) and secure in place with retaining ring.
7. Install rod and piston (5) in crankcase.
8. Measure piston and oil ring gaps with piston and rod (5) installed in cylinder bore.

Piston Ring Gap Clearance: 0.002 to 0.004 in. (0.05 to 0.010 mm).

Oil Ring Gap Clearance: 0.0015 to 0.0035 in. (0.04 to 0.09 mm).

9. Align matching marks of rod cap (6) and piston rod (5). Install rod cap (6) and bolts (7).
10. Install new gasket (8). Install cover (9), and bolts and lockwashers (10).
11. Install new seal (11), cover (12), and bolts and lockwashers (13).

end by:

- a) install head assembly

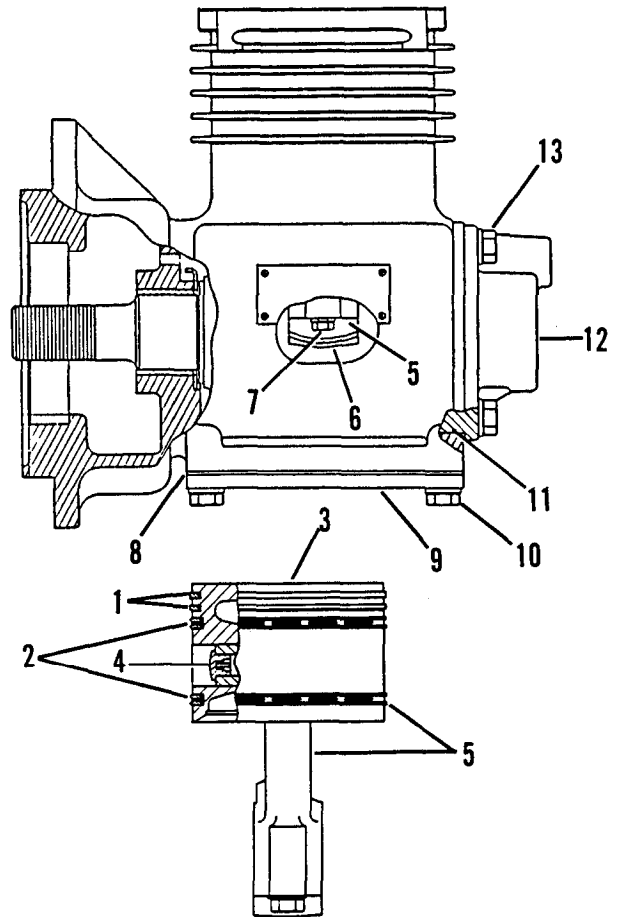

ENGINE

CRANKSHAFT**REMOVE CRANKSHAFT**

start by:

a) remove piston and rod

1. Use a suitable press to remove crankshaft (1) from the crankcase (2).
2. Push crankshaft (1) and bearings (3) out of crankshaft, as a unit, in the direction shown in the illustration.
3. Remove bearings (3) and two washers (4) from crankshaft. Discard bearings.

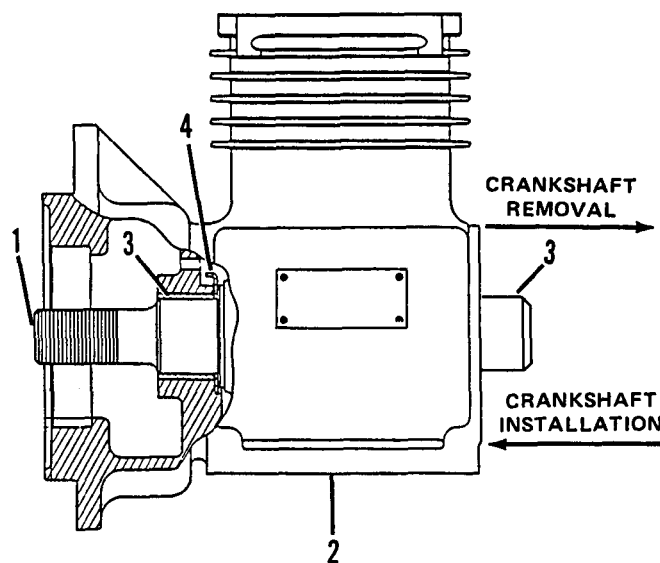
**INSTALL CRANKSHAFT**

1. Install two washers (4) and new bearings (3) onto crankshaft (1).
2. Install crankshaft (1), with bearings, in the direction shown in the illustration.

end by:

a) install piston and rod

AIR GOVERNOR

Models 950BNS and 950BS

DISASSEMBLE AIR GOVERNOR

15-1 065

1. Remove air governor from air compressor. Remove air line (1) from body (11).
2. Put a mark (A) on cover (4) and body (11) so the cover can be installed on the body in the correct location.
3. Measure the distance from cover (4) to the top of screw (5) and make a record of the measurement. Loosen the locknut and remove screw (5).
4. Remove four screws (2), identification tag (3), cover (4), spring (6) and spring seat (7).
5. Remove nut (8), plunger (10) and diaphragm (9) as a unit.
6. A rod with a diameter of .12 in. (3.05 mm) put in the hole in plunger (10) is used to hold the plunger when nut (8) is removed.
7. Remove screw (17) and exhaust diaphragm (16).
8. Remove exhaust nut (14), spring (15), exhaust valve (12) and spring retainer (13).
9. Clean all of the parts and the passages in body (11) and plunger (10).

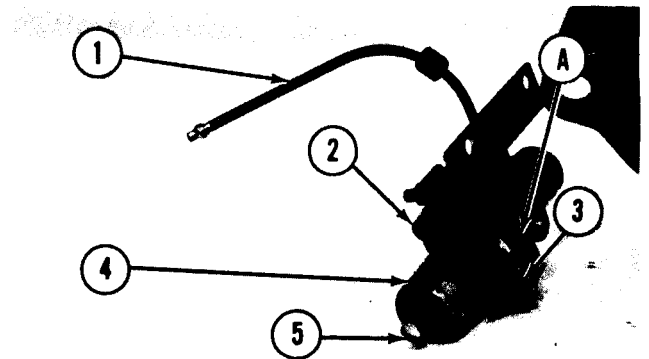

80912X3

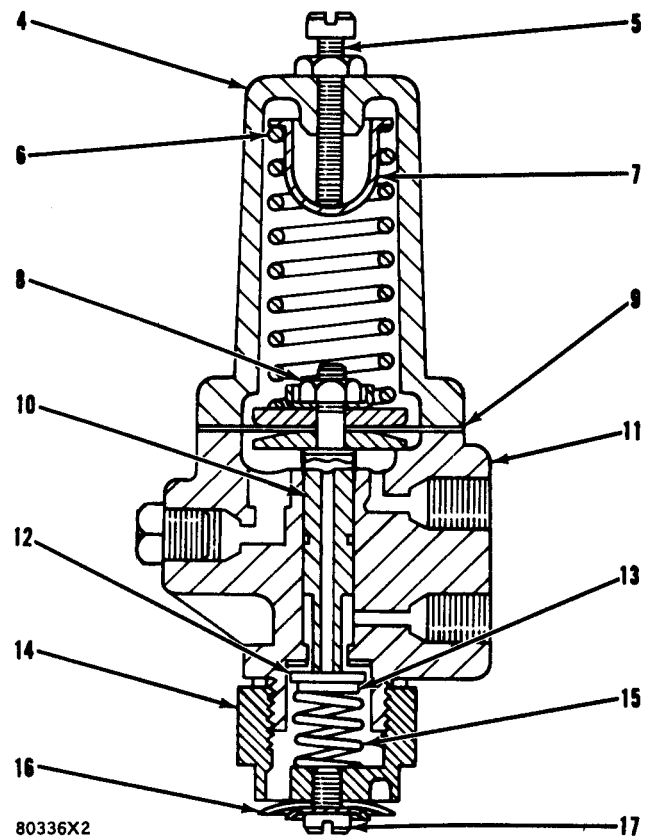

80336X2

ENGINE

AIR GOVERNOR

Models 950BNS and 950BS

ASSEMBLE AIR GOVERNOR

16-1065

1. Install seal (12) on plunger (11).
2. Put new soft washer (10), follower (9), new diaphragm (8), follower (7), spring guide (5) and new nut (6) on plunger (11).

NOTE: The diaphragm is between the chamfered sides of followers (7) and (9).

3. A rod with a diameter of .12 in. (3.05 mm) put in the hole in plunger (11) is used to hold the plunger when nut (6) is tightened.
4. Lubricant is put on plunger (11) and in body (13). Install plunger in body.
5. Install spring seat (3) in spring (4) and put them on spring guide (5).
6. Install cover (2) over spring seat (3) and spring (4). Mark (A) on cover (2) must be in alignment with mark (A) on body (11) when the four lockwashers and screws in the cover are tightened.

NOTE: The governor identification tag is under one of the four screws.

7. Install screw and nut (1) in cover (2). Make an adjustment for the length of the screw to get the same measurement before the screw was removed from the cover.
8. Install screw and diaphragm washer (20) and new exhaust diaphragm (19) on exhaust nut (18).
9. Install spring (17), spring retainer (16) and new exhaust valve (15) in exhaust nut (18).
10. Install washer (14) and exhaust nut (18), spring retainer and spring in body (13). Install air governor and air line on air compressor.

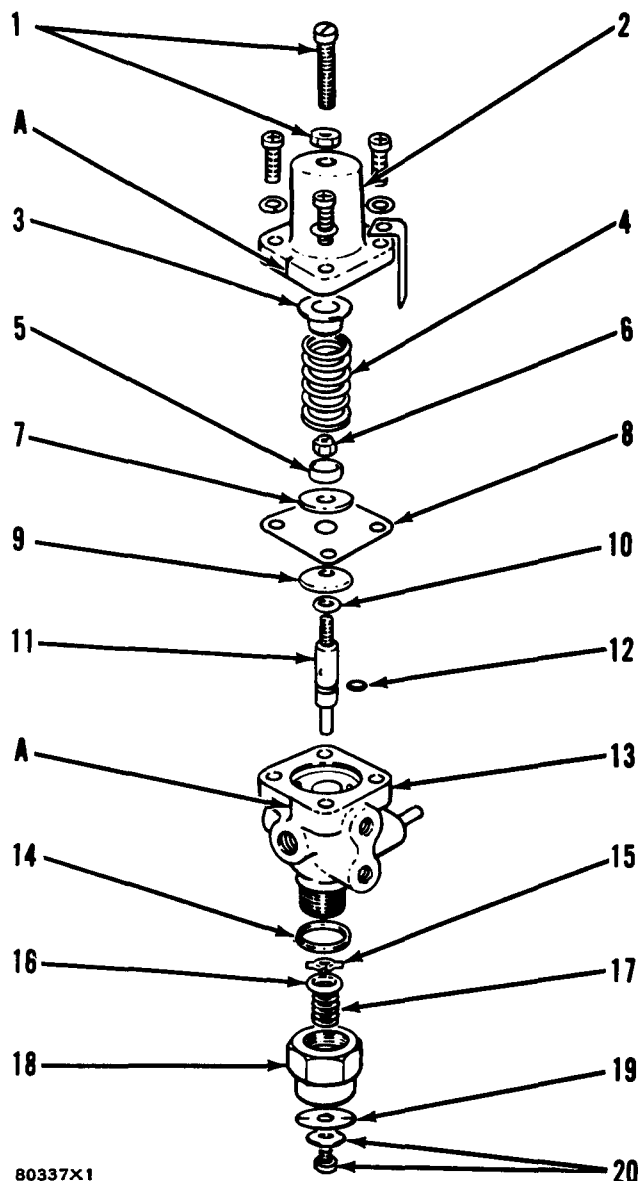

80337X1

ENGINE

DISASSEMBLY AND ASSEMBLY

AIR GOVERNOR

Models 950 BNSCE and 950BSCE

DISASSEMBLE AIR GOVERNOR

1. Unscrew cover (1) until cover is released from governor adjusting screw (2). Remove O-ring (3).
2. Remove spring retaining ring (4).
3. Pull adjusting screw (2) with spring assembly (5) out of governor body (6).

NOTE: Spring assembly (5) is not normally disassembled. Parts of this assembly cannot be purchased separately.

4. To disassemble spring assembly (5), remove locknut (7) and spring seat (8) from adjusting screw (2).
5. Remove spring (9), lower spring seat (10), spring guide (11), and the remaining lower spring seat (12).
6. Gently tap the open end of the valve body on a flat surface to remove exhaust stem (13), spring (14) and piston assembly (15).

NOTE: Items (13) and (15) may be made of either metal or plastic.

7. Remove O-rings (16) from the piston assembly.
8. Using a hooked wire, remove O-Ring (17) from piston assembly. On plastic piston assemblies (15) it may be necessary to remove washer (18) and retaining ring (19) before removing O-ring (17).
9. If piston assembly is plastic, insert the blade of a small screwdriver between the two ears of retaining ring (20) and pry retaining ring (20) out of piston. Remove valve spring (21) and inlet/exhaust valve (22).
10. If piston assembly is metallic, remove valve spring (21) from recess in piston. Remove inlet/exhaust valve (22).

WARNING

If NBC exposure is suspected, all air filter media should be handled by personnel wearing protective equipment. Consult your unit NBC Officer or NBC NCO for appropriate handling or disposal instructions.

11. Remove and discard filters (23) from unloader and reservoir ports in governor body.

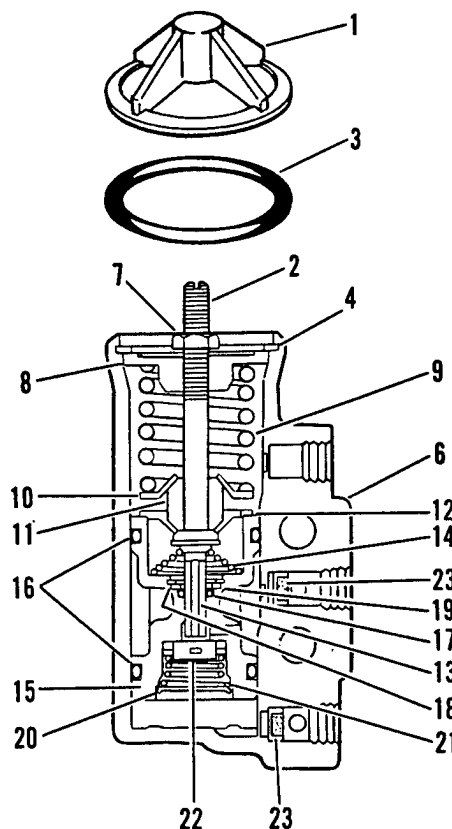

5 — 2, 7, 8, 9, 10, 11, 12

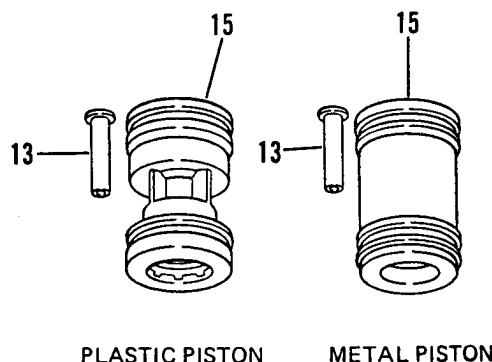

AIR GOVERNOR

Models 950BNSCE and 950BSCE

ASSEMBLE AIR GOVERNOR

1. Prior to assembly, lubricate the two lower body bores, all O-rings and O-ring grooves.
2. Install O-ring (1) in piston (2).
3. On plastic pistons only, install washer (3) and retaining ring (4).
4. Position inlet/exhaust valve (5) into bottom of piston (2).
5. If piston is plastic, install spring (6) with small end of spring against valve (5). Install retaining ring (7) on top of the large end of spring (6). Make sure that the concave side of retaining ring (7) is facing away from piston (2). Press retaining ring into piston (2) with finger pressure only. Do not use a pressor or hammer to install retaining ring.
6. If piston is metallic, install spring (6) with the small end of the spring against valve (5). Press the spring down until the larger coiled end snaps into the recess in piston (2).
7. Install piston O-rings on piston (2).
8. Install exhaust stem spring (8) in piston (2). Make sure that the large coil end of spring is next to piston (2).
9. Install exhaust stem (9) in piston (2) through spring (8) into piston (2).
10. Install lower spring seat (10), spring guide (11), spring seat (12), spring (13), and hex shaped upper spring seat (14) on adjusting screw (15).
11. Screw the upper spring seat (14) onto adjusting screw (15) until the distance from the top of the seat to the bottom of the adjusting screw head is approximately 1-7/8 inches.
12. Install locknut (16).
13. Install adjusting screw and spring assembly in the governor housing.

WARNING

If NBC exposure is suspected, all air filter media should be handled by personnel wearing protective equipment. Consult your unit NBC Officer or NBC NCO for appropriate handling or disposal instructions.

14. Install snap ring (17). Make sure that snap ring is completely seated in the groove in the governor housing.
15. Install O-ring (18) and cover (19).
16. Install filters (20) in governor housing.

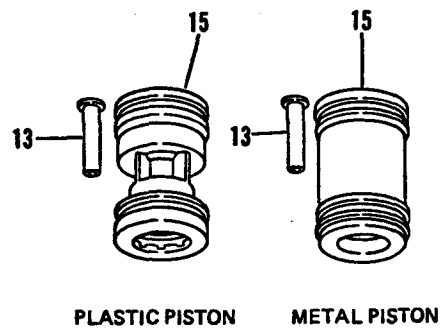
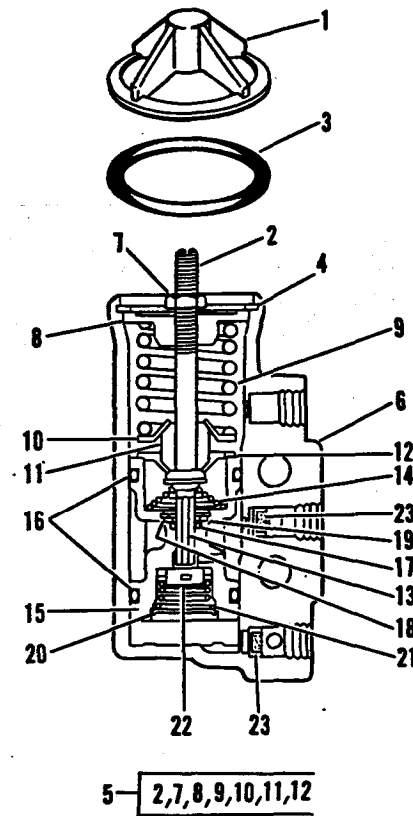

ENGINE

FAN

REMOVE FAN

1356-11

- start by:
a) rem-eve hood

NOTE: The vee belt can be disconnected from the alternator for easier access to the fan bolts.

1. Drain the coolant from the cooling system.

2. Loosen hose clamps (2) and (3) and remove tube assembly (1) from the radiator and engine.

3. Remove bolts (5) and fan guard (4) from the radiator.

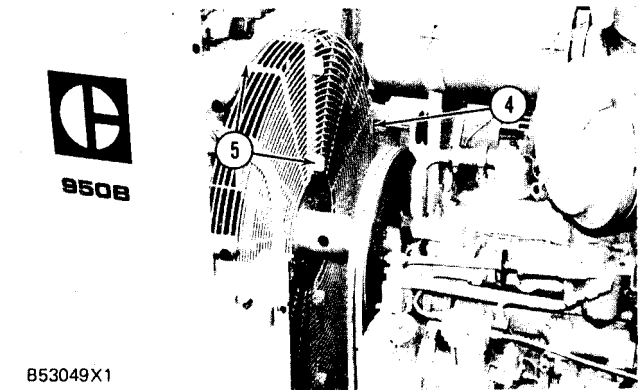
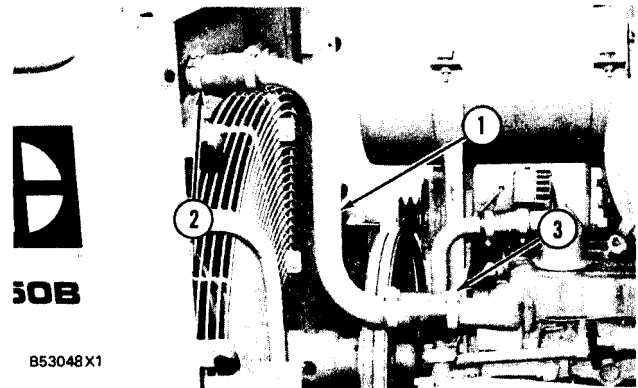

CAUTION
Do not damage the radiator core with fan (6).

4. Fasten a strap and hoist to fan (6) as shown.

5. Remove bolts (7) and disconnect fan (6) from the adapter.

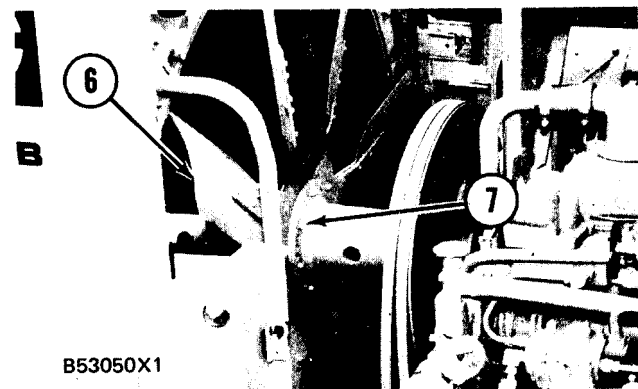

6. Carefully put fan (6) against the radiator.

7. Remove bolts (9) and adapter (8) from the fan drive.

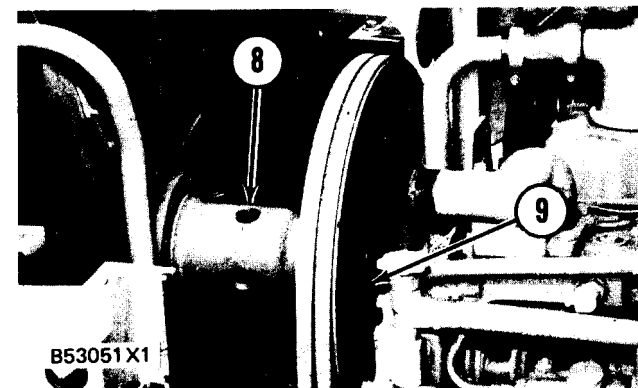

8. Remove fan (6) from the machine.

FAN

INSTALL FAN

1356-12

CAUTION

Do not damage the radiator core with fan (2).

1. Put fan (2) in position on the machine and carefully put it against the radiator as shown.

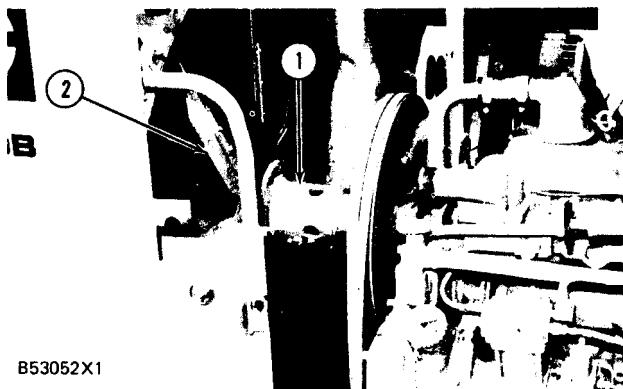

2. Install adapter (1) on the fan drive.

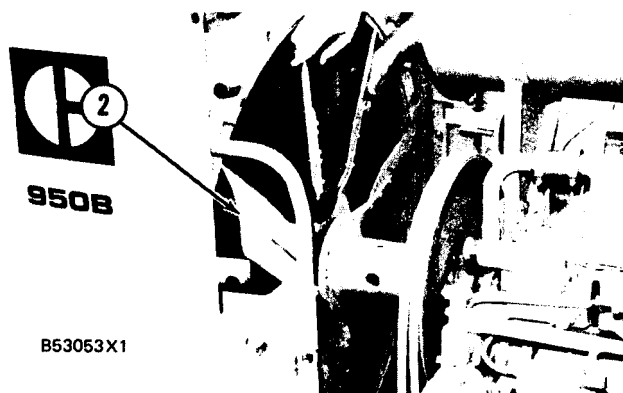

3. Put fan (2) in position on the adapter and install the bolts that hold it.

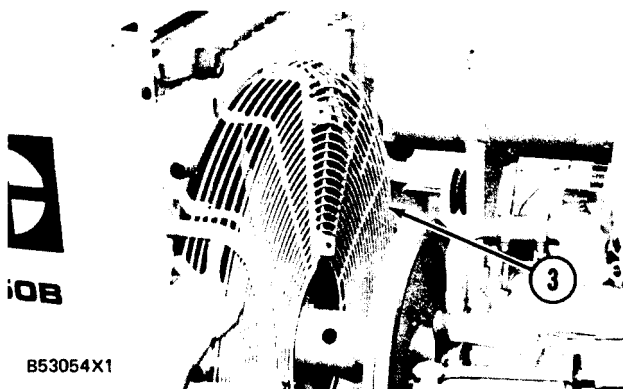

4. Install fan guard (3) on the radiator.

5. Install tube assembly (4) on the engine and radiator as shown.

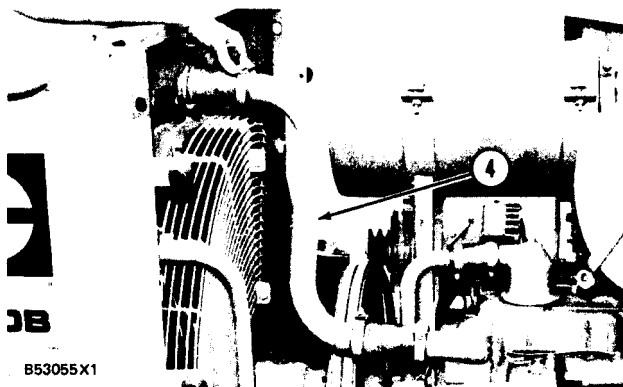

6. Fill the cooling system with coolant.
end by:
a) install hood

FAN DRIVE

REMOVE FAN DRIVE

1359-11

start by:
a) remove hood

1. Loosen the lower nut on adjusting rod (1) to loosen the vee belt tension.

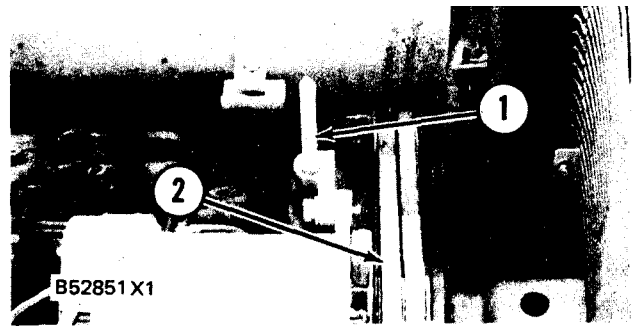

2. Remove the vee belts (2) from the alternator pulley.

CAUTION

Do not damage the radiator core when the fan is disconnected from the fan drive.

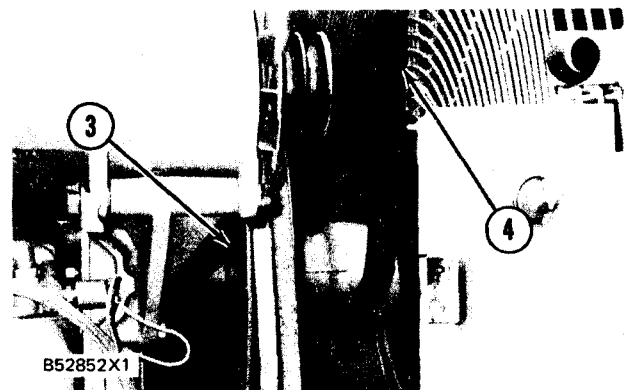

3. Fasten strap (4) and hoist to the adapter and fan.

4. Remove bolts (3) that hold the adapter and fan to the fan drive.

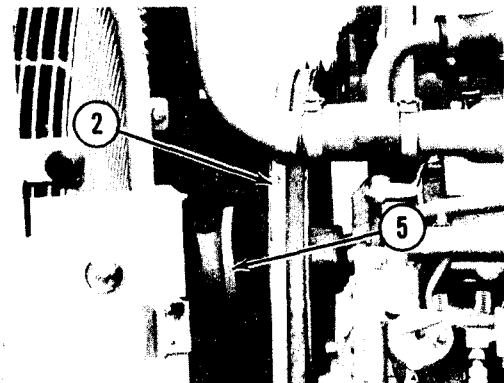

5. Carefully put the fan and adapter (5) in position against the radiator core.

6. Remove vee belts (2) from the fan drive.

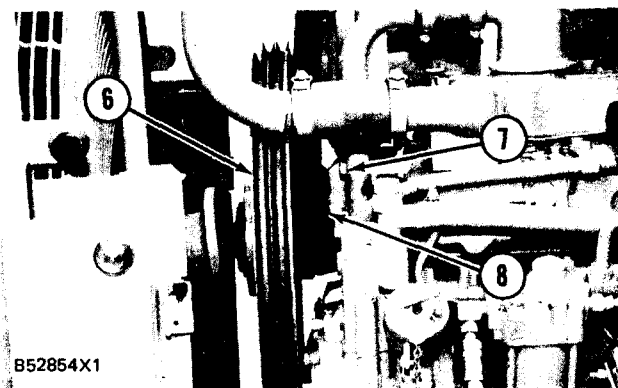

7. Fasten strap (8) and a hoist to fan drive (6).

8. Remove bolts (7), the nuts and fan drive (6).
The weight of the fan drive is 29 kg (65 lb.).

FAN DRIVE

INSTALL FAN DRIVE

1359-12

1. Fasten a strap and hoist to fan drive (1) and put it into position on the engine and install the nuts and bolts.

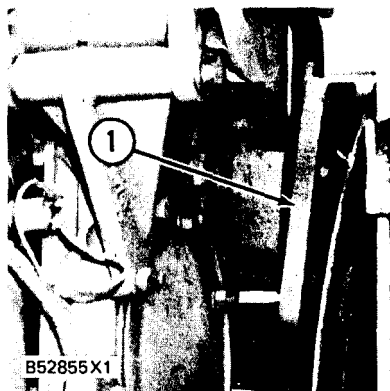

2. Install vee belts (2) on the fan drive as shown.

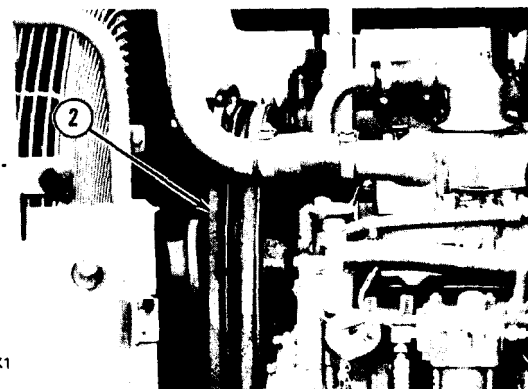

3. Fasten strap (3) and a hoist to adapter (4) and the fan.

4. Put adapter (4) and the fan in position and install the bolts.

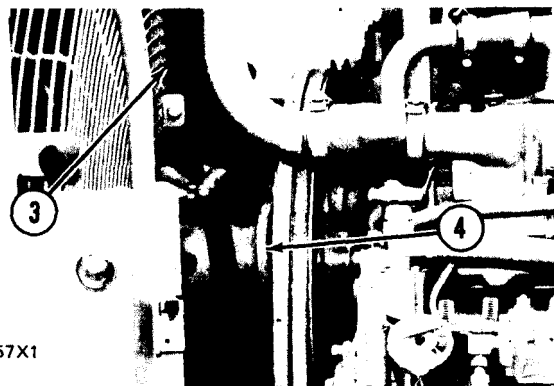

5. Install vee belts (5) on the alternator pulley as shown.

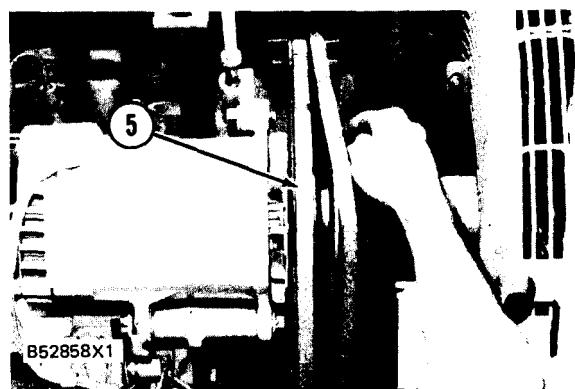

6. Use a belt tension gauge such as Borroughs Tool Company Part No. BT-33-72C or an equivalent and make an adjustment of vee belts. Measure the belt nearest the radiator. Tighten new belts until the gauge indication is 534 ± 22 N (120 ± 5 lb.). Tighten the bolts that hold the alternator in position. Operate the engine at high idle for a minimum of 30 minutes. Make another adjustment of the belt tension. The correct gauge indication for used belts is 400 ± 44 N (90 ± 10 lb.).

end by:

- a) install hood

FAN DRIVE

DISASSEMBLE FAN DRIVE

1359-15

start by:

a) remove fan drive

1. Remove O-ring seal (2) from around the bearing.

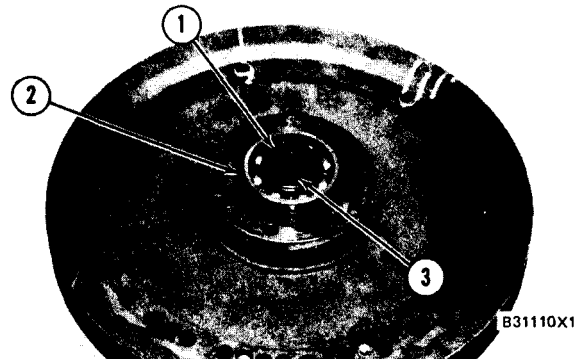

2. Bend the tabs on lock (1) down.

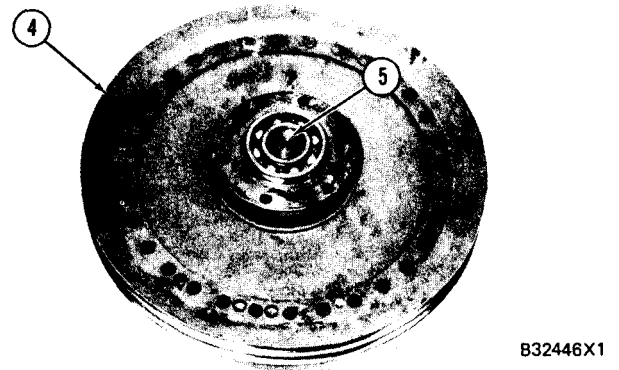

3. Remove the bolts, lock (1) and washer (3).

4. Remove pulley (4), the spacer and the hub from shaft assembly (5).

5. Remove bearing (6) from the hub. Remove the pulley from the hub.



NOTE: Bearing (7) and lip type seal (8) can stay with the pulley and hub when it is removed.

6. Remove bearing (7) and lip type seal (8) from shaft assembly (5).



7. Remove the spacer from the shaft assembly.

FAN DRIVE

ASSEMBLE FAN DRIVE

1359-16

	Tools Needed	A
1P510	Driver Group	1

1. Install pulley (1) on hub (2) as shown.

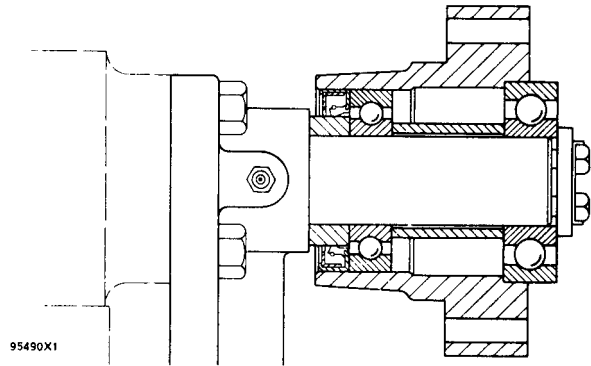

NOTE: The pulley must be installed on the hub with the spacer down against the shoulder of the hub.

2. Install the bearing in the hub.
3. Use tooling (A) to install lip type seal (4) in the hub with the lip of the seal up. The top of the seal must be even with the end of the hub.

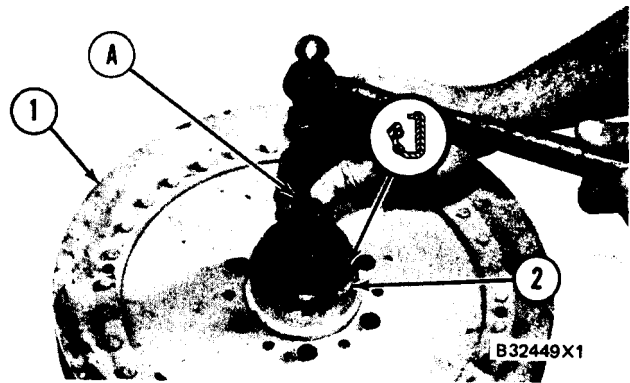

4. Put 5P960 Multipurpose Type Grease on the lip of the seal.

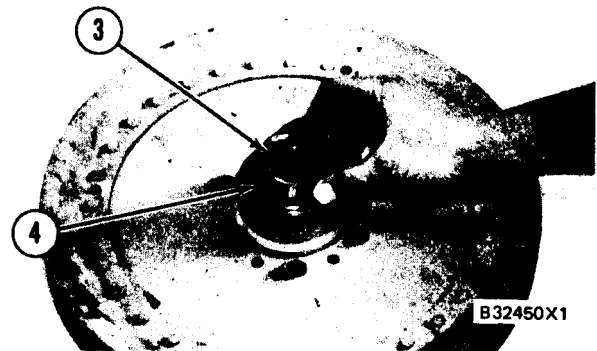

5. Install spacer (3) in seal (4).

NOTE: Make sure mounting bolts (7) are put in position before the pulley and hub are installed on the shaft.

6. Put pulley and hub assembly (5) on shaft assembly (6).

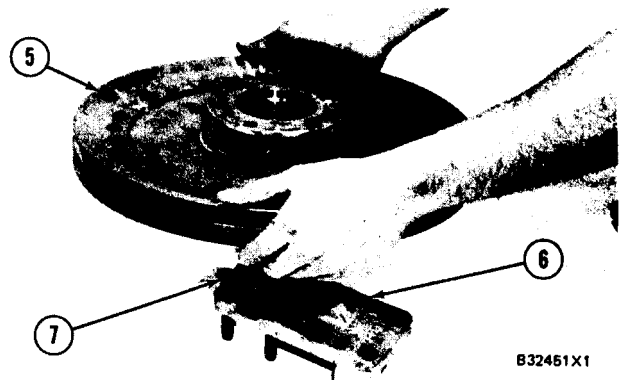

FAN DRIVE

7. Install spacer (8) on the shaft assembly.

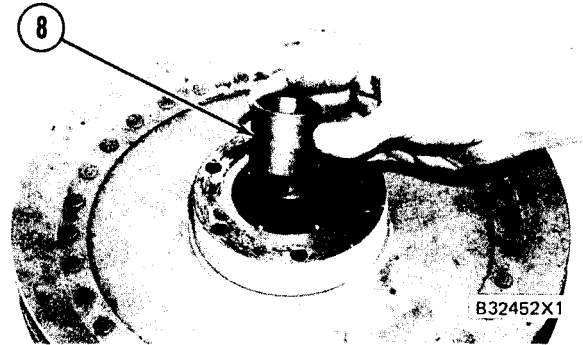

8. Fill the hub with 5P960 Multipurpose Type Grease.



9. Put bearing (9) in position in the hub. Make sure the bearing makes a seat in the counter-bore of the hub.

10. Put washer (10) in position on the bearing.

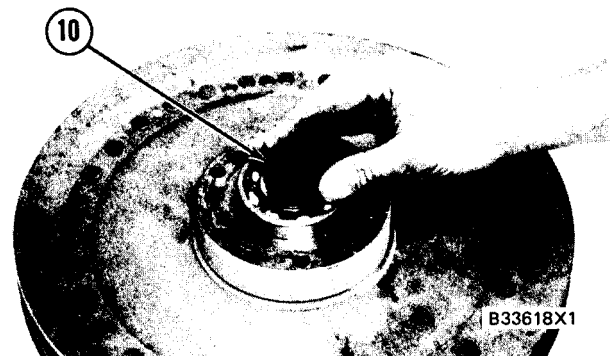

11. Install lock (13) and bolts (12). Bend the tabs on the lock around the bolts.

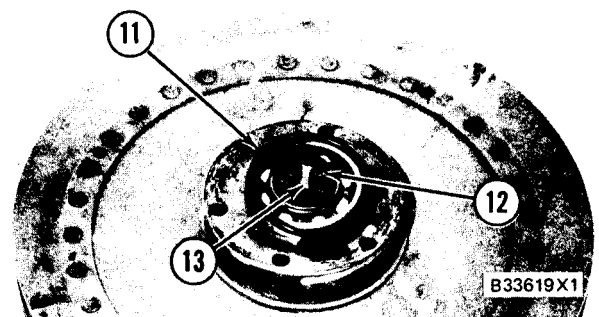

12. Install O-ring seal (11) on the hub.
end by:
a) install fan drive

WATER PUMP

REMOVE WATER PUMP

1361-11

1. Drain the coolant from the cooling system.

2. Loosen the clamp and disconnect hose (1).

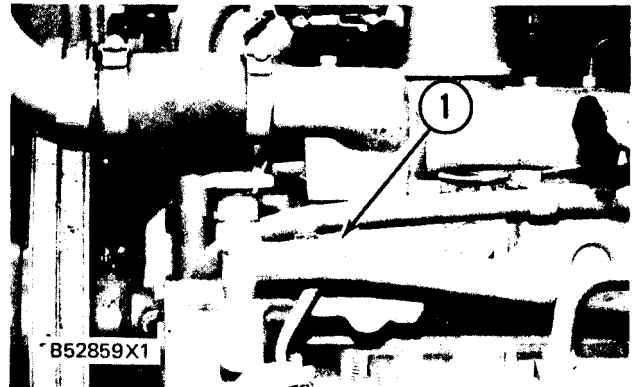

3. Loosen clamps (2) and disconnect hose (3) from the water pump.

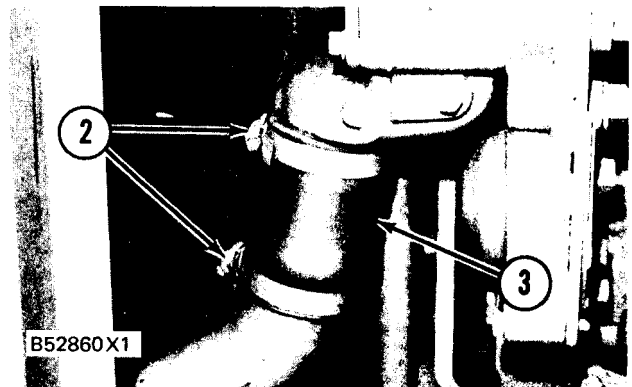

4. Put marks on wires (4) and disconnect them from the sending unit.

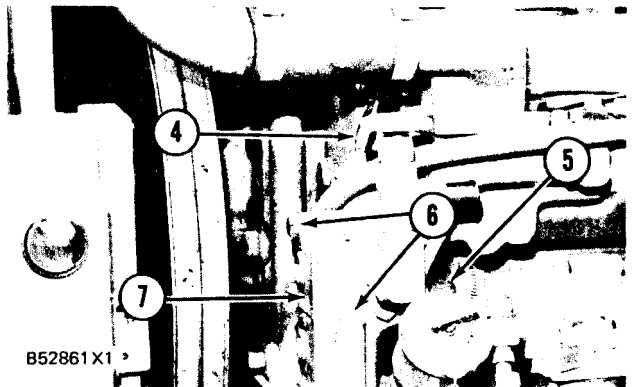

5. Loosen the clamp that holds hose (5) to elbow (7).

6. Remove bolts (6) and elbow (7) from the water pump.



7. Loosen the nut on adjusting rod (8) to loosen the tension on the vee belts.

ENGINE

WATER PUMP

8. Fasten strap (9) and a hoist as shown for support of the fan drive. Loosen bolts (10) and the nuts so there is enough clearance to remove the water pump bolts.

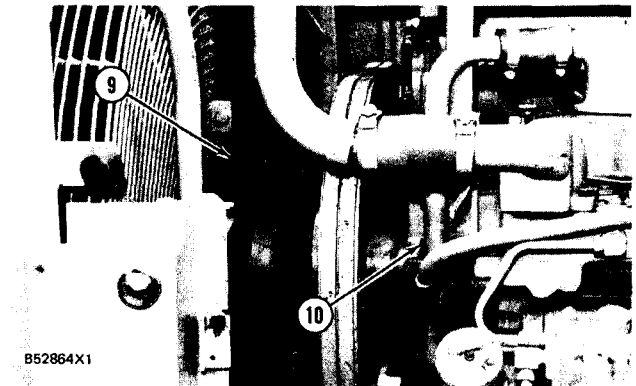

9. Loosen two bolts (12) so water pump (11) and O-ring seal can be removed from the front cover.

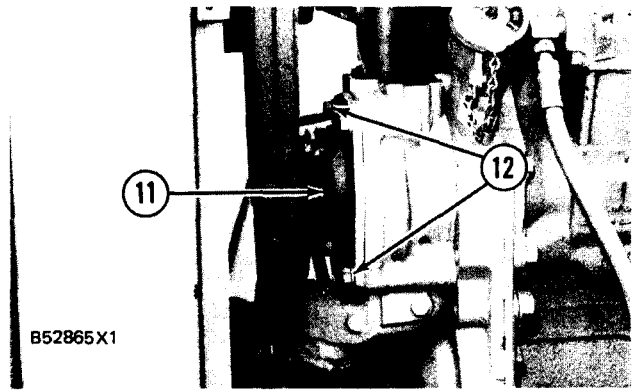

INSTALL WATER PUMP

1361-12

1. Make sure O-ring seal is in position on water pump (1).

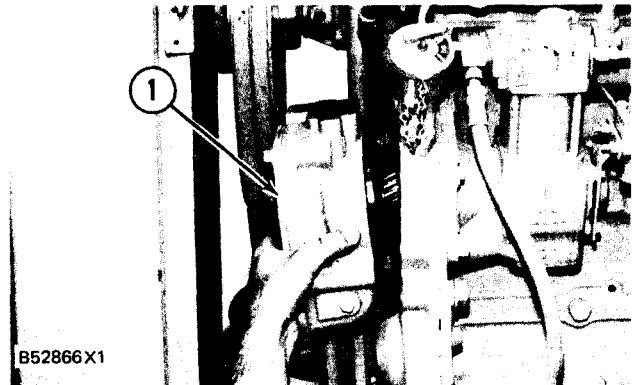

2. Install water pump (1) on the front cover as shown.

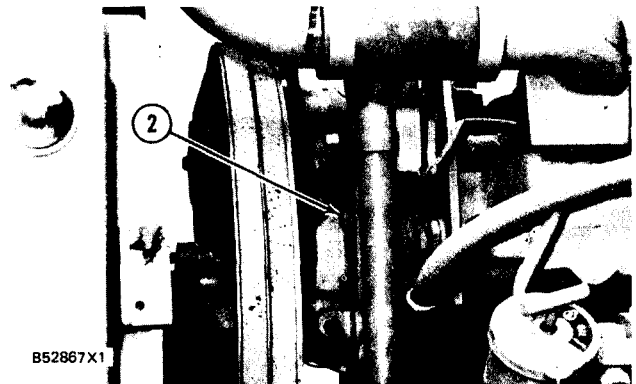

3. Tighten bolts (2) and the nuts that hold the fan drive to the engine.

WATER PUMP

4. Tighten vee belts (3) to the correct tension. See INSTALL FAN DRIVE.

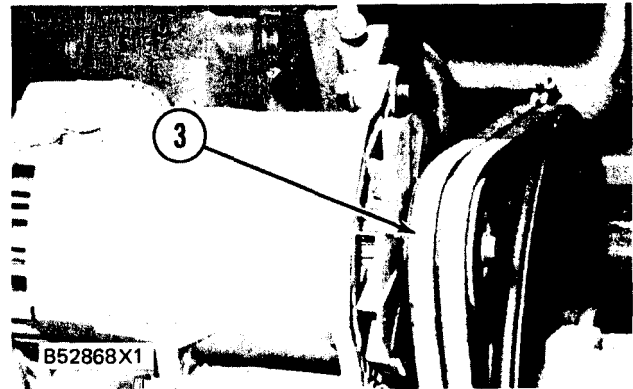

5. Make sure all gasket surfaces are clean and free of dirt.

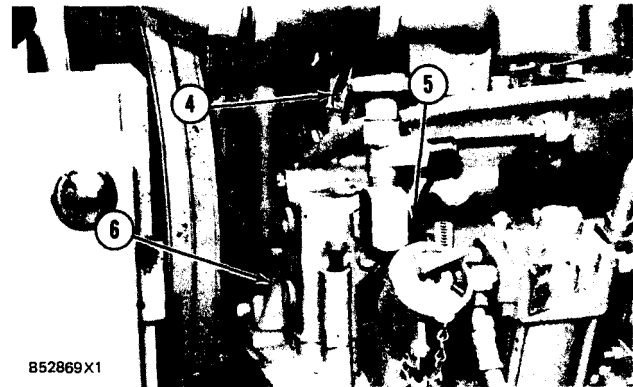

6. Install the gaskets and elbow (6) on the water pump.

7. Tighten the clamp that holds hose (5) to the elbow.

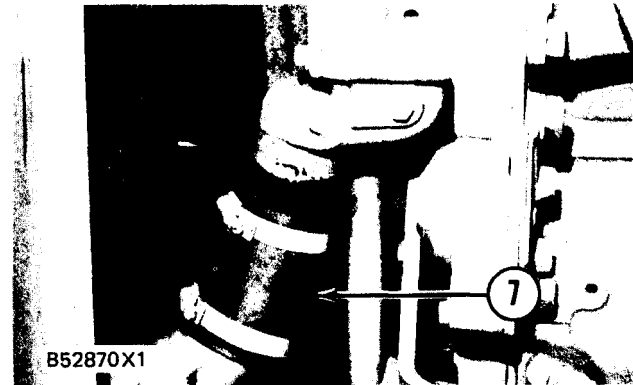

8. Connect wires (4) to the sending unit.

9. Connect hose (7) to the water pump.

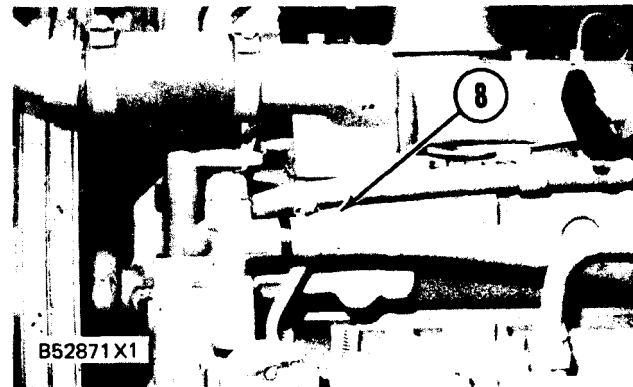

10. Connect hose (8) to the elbow and tighten the clamp.

11. Fill the cooling system with coolant to the correct level.

ENGINE

WATER PUMP

DISASSEMBLE WATER PUMP

1361-15

Tools Needed		A	B	C
8H663	Bearing Puller Attachment	1		
5P475B	Pliers		1	
1P510	Driver Group			1

start by:

a) remove water pump

1. Turn the housing over and remove bolt and washer (7). Remove bearing (8) and gear (9) as a unit.
2. Use tool (A), tooling (C) and a press to remove bearing (8) from gear (9).
3. Remove snap ring (10) with tool (B).
4. Remove cover (1) from water pump (2).
5. Loosen bolt (3) 6.35 mm (.25 in.). Hit the bolt with a soft hammer to remove impeller (4) from the shaft.

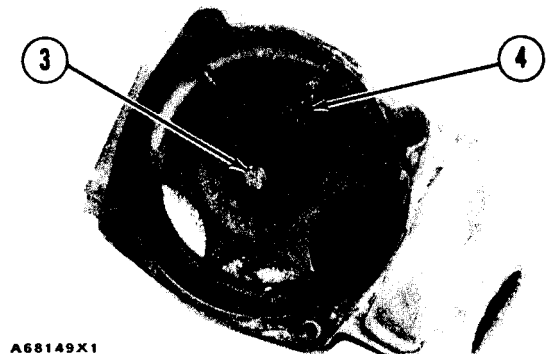
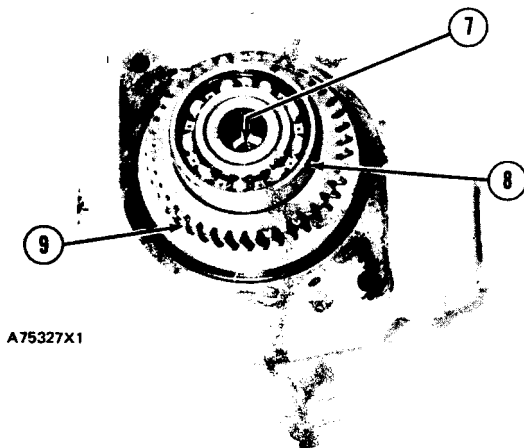
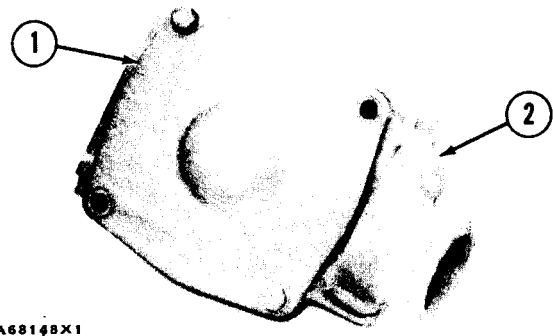
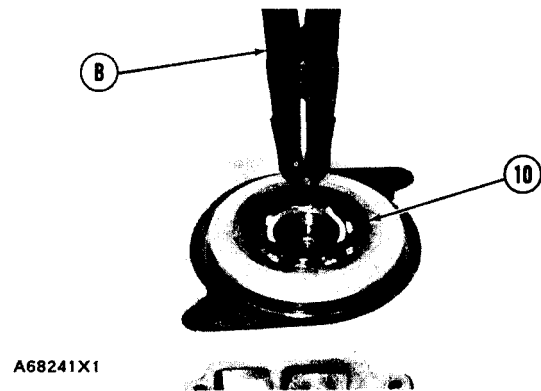
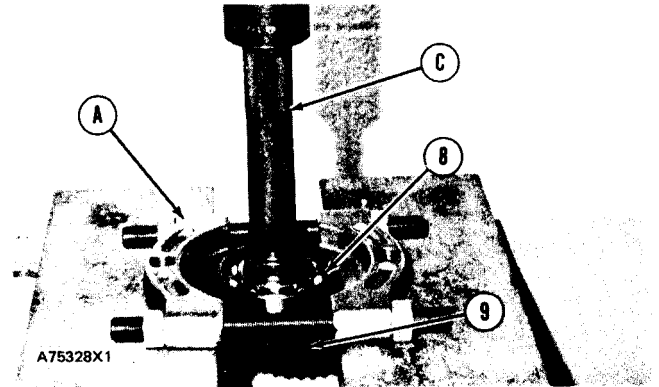

WATER PUMP

6. Remove spring and seal assembly (5) from the shaft (6).

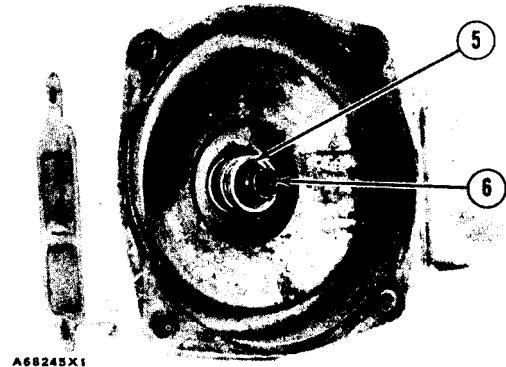

7. Remove bearing (11) and shaft (6) as a unit.

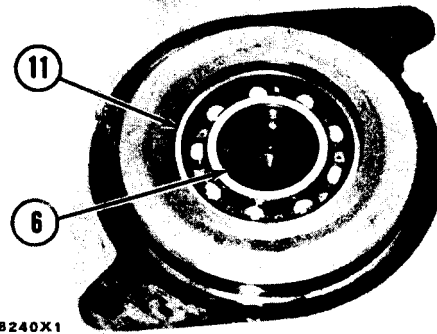

8. Use tool (A) and a press move bearing (11) from the shaft.

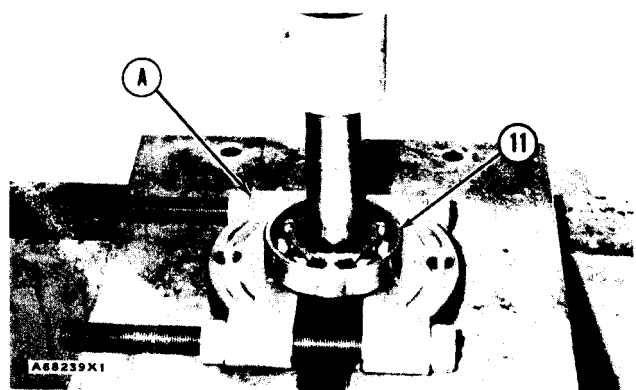

9. Remove the ceramic ring and seal (12) from the housing.

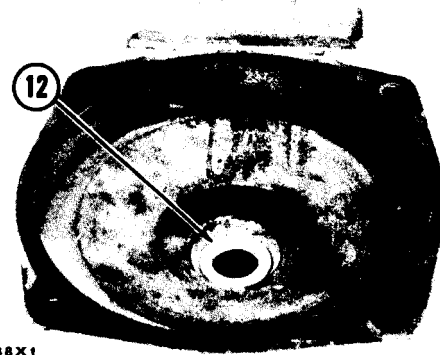

10. Remove the lip seal (13) from the housing with tool (c).

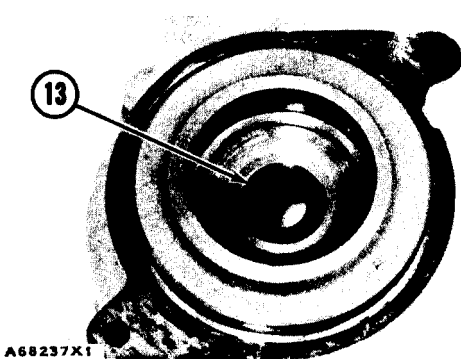

WATER PUMP

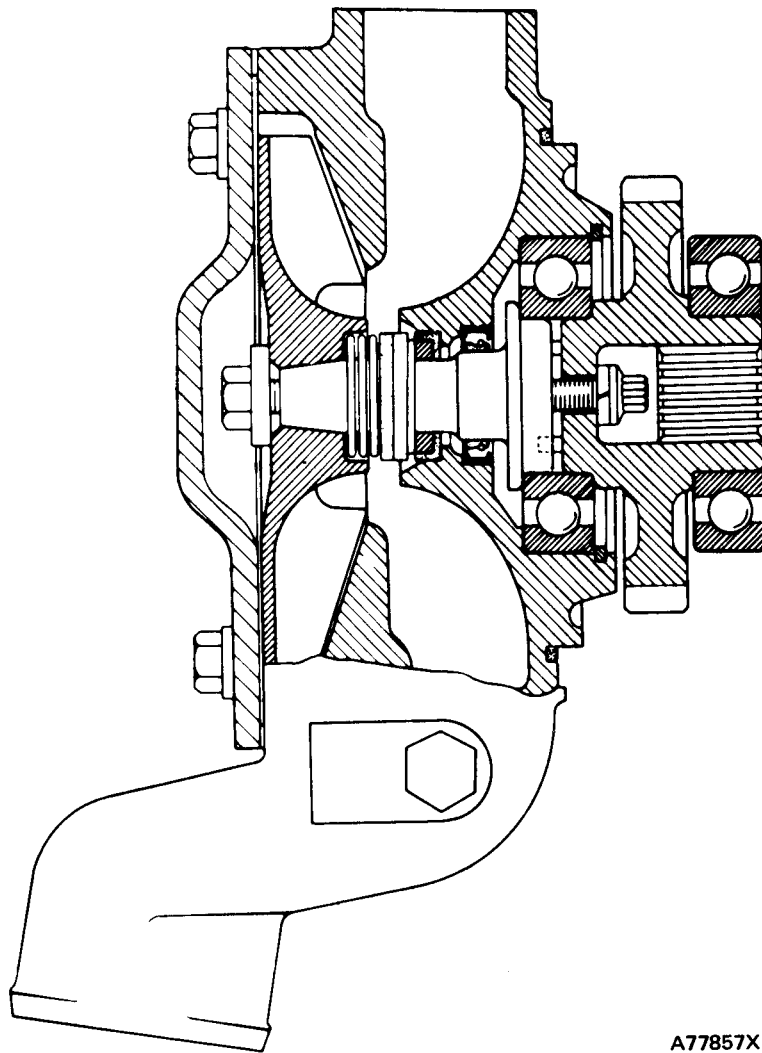

A77857X1

WATER PUMP

ASSEMBLE WATER PUMP

1361-16

Tools Needed		A	B
1P510	Driver Group	1	
5P4758	Pliers		1

1. Install lip seal in water pump housing with tooling (A). The lip of the seal must be toward the bearings. Put clean SAE 30 engine oil on the lip of the seal.

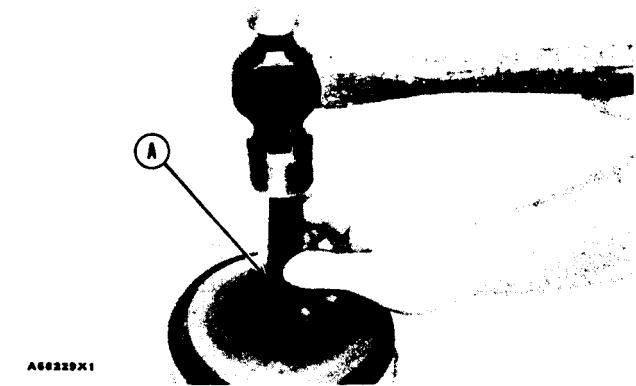

2. Use a press to install shaft (1) in bearing (2).

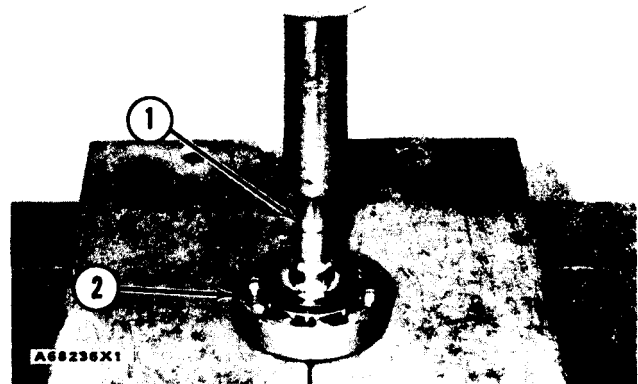

3. Install the shaft (1) and bearing in the housing (3).

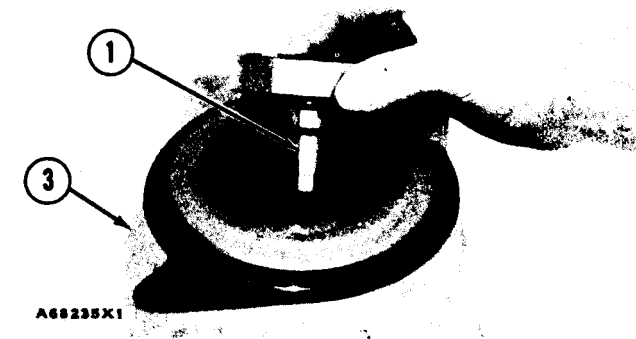

4. Install snap ring (4) in housing with tool (B).

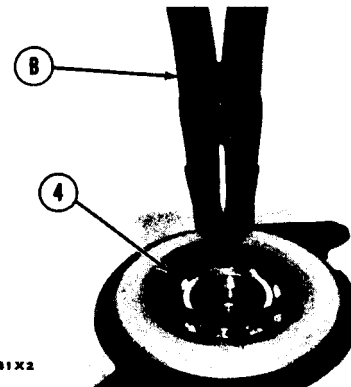

5. Use a press and tooling (A) to install bearing (5) on gear (6).

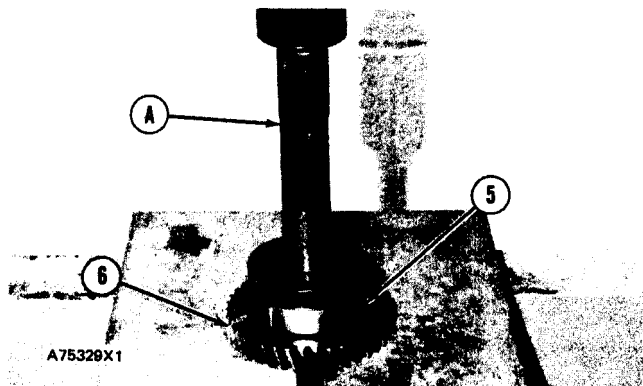

WATER PUMP

6. Put gear (6) and bearing in position on shaft and install bolt and washer.

CAUTION

Clean water only is permitted for use as a lubricant for assembly. Do not damage or put hands on the wear surface of the carbon ring or the ceramic ring. Install the ceramic ring with the smoothest face of the ring toward the carbon seal assembly.

7. Put the ceramic ring (7) in position in the rubber seal. Use hand pressure and the tool (which is with the replacement ring) to install the ceramic ring.

8. Remove spring from the seal assembly (8). Use hand pressure and the tool (which is with the replacement ring) to install the seal assembly. Push seal assembly on shaft until seal faces make light contact.

9. Install spring (9). Put impeller (10) in position and install washer and bolt. Tighten bolt to a torque of 38 ± 1.4 N·m (27 ± 1 lb. ft.).

10. Install gasket and cover on the housing.

end by:

- a) install water pump

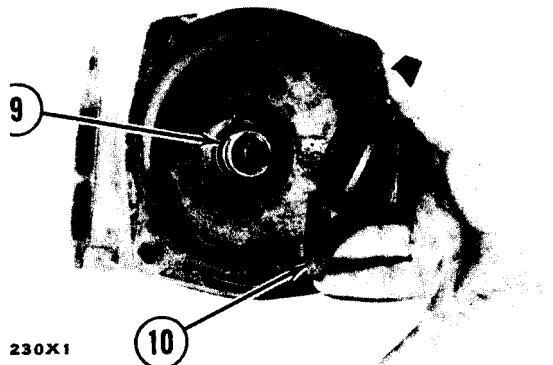
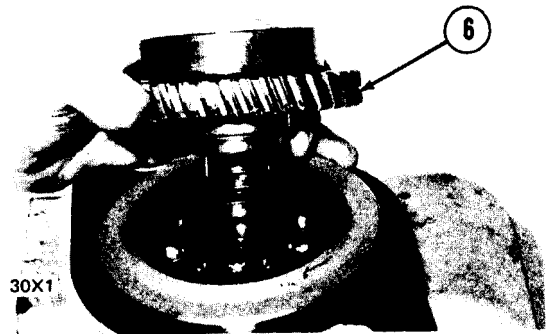

WATER TEMPERATURE REGULATOR

REMOVE WATER TEMPERATURE REGULATOR

1355-11

NOTE: Model 950BSCE and 950BNSCE have radiator hoses slightly different from 950BS and 950BNS. 950BS and 950BNS are shown. Procedure is similar for both.

1. Drain the coolant from the cooling system.
2. Loosen hose clamps (1) and slide hose (3) on to the tube assembly.
3. Remove the bolts and adapter (2) from the cylinder head.
4. Remove the gasket and water temperature regulator (4) from the cylinder head.

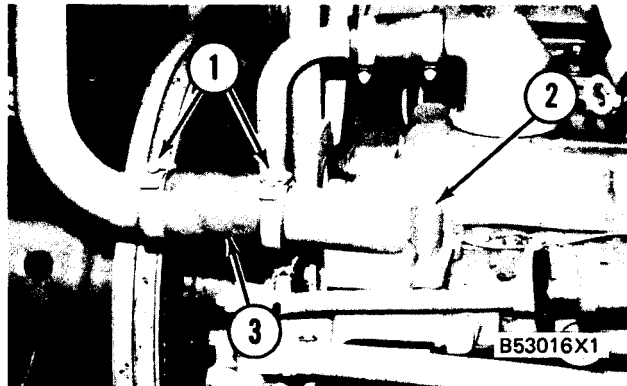

INSTALL WATER TEMPERATURE REGULATOR

1355-12

1. Clean all gasket material and rust from contact surfaces.
2. Install water temperature regulator (2) in the cylinder head with the spring toward the inside as shown.

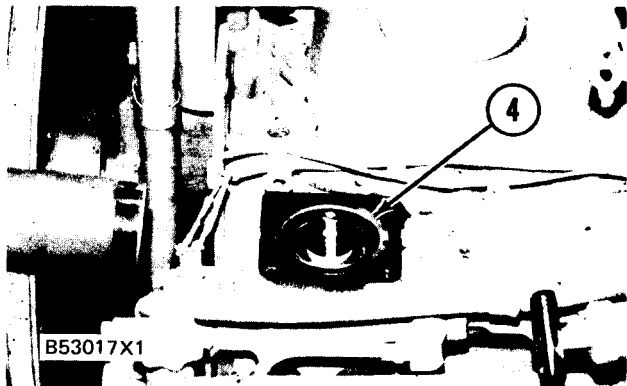

CAUTION

The engine will run hot if the water temperature regulator is installed wrong.

3. Install the gasket with the notch over vent hole (1) in the cylinder head.

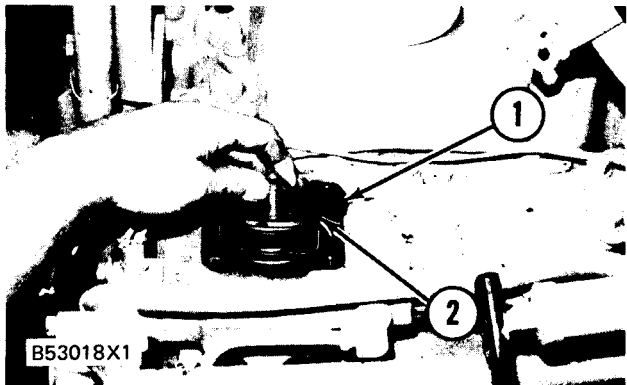

CAUTION

Make sure the vent hole is open and do not use liquid gasket material on the gasket. The cylinder head can be damaged if the vent hole is not open or if the gasket is installed wrong.

4. Install adapter (4) on the cylinder head.
5. Put hose (3) in position on adapter (4) and tighten the clamps.
6. Fill the cooling system to the correct level with coolant.

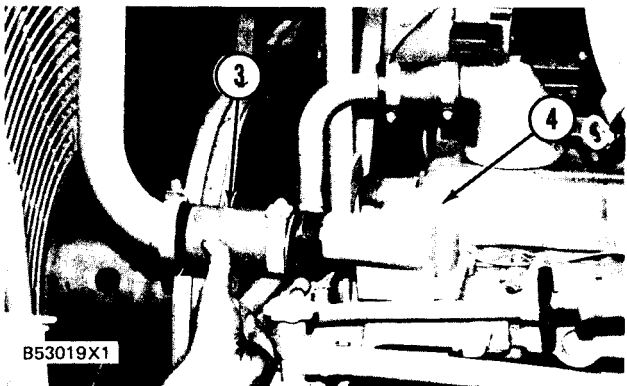

TORQUE CONVERTER OIL COOLER

REMOVE TRANSMISSION OIL COOLER

1366-11

1. Drain the engine and radiator coolant.
2. Remove the bolts and disconnect tube assembly (1), the flange and clip from the transmission oil cooler.
3. Remove bolts (2) and (5) and remove lower tube assembly (3) and flange (4).
4. Remove bolt (7) and disconnect bracket (6) from the transmission oil cooler.
5. Remove four bolts (9) and transmission oil cooler (8) from the engine.
6. Remove bolts (10), nuts (11) and bonnet (12) from the transmission oil cooler.

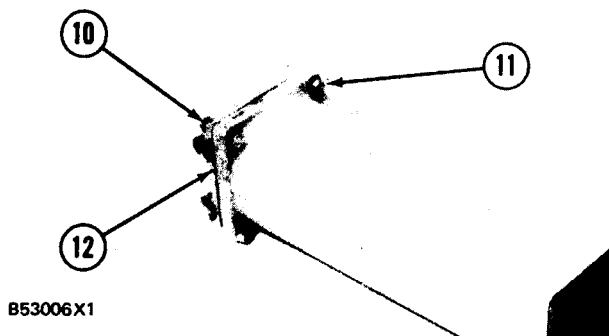
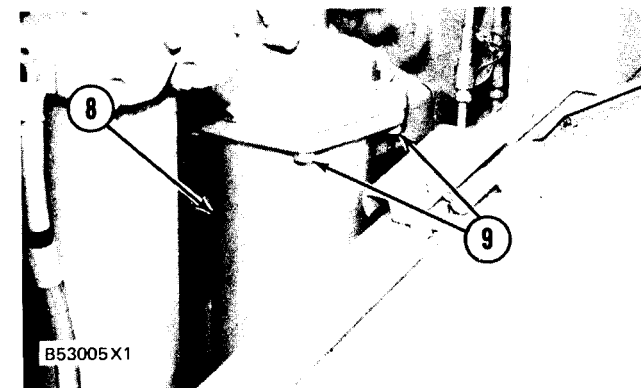
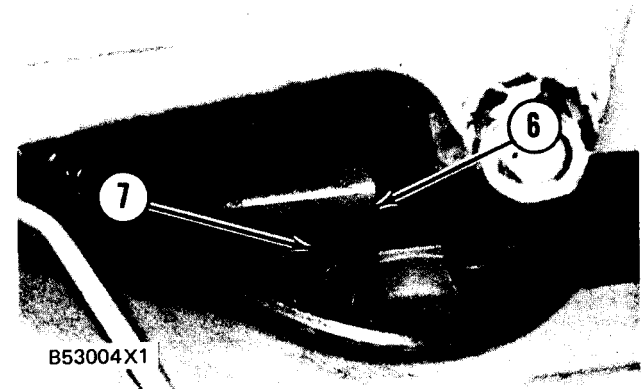
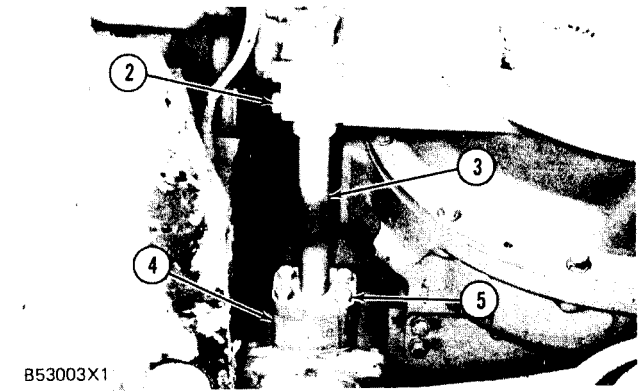
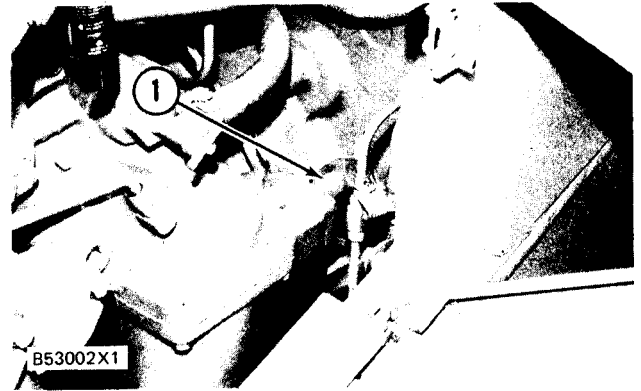

TORQUE CONVERTER OIL COOLER

- Clean the tubes of the transmission oil cooler with a 3.175 mm (.125 in.) diameter rod (13) as shown.



B53007X1

INSTALL TRANSMISSION OIL COOLER

1366-12

- Clean all gasket surfaces.
- Install the gasket and bonnet (1) on the transmission oil cooler.
- Put gasket (2) and transmission oil cooler (3) into position on the engine with the bolts that hold it.
- Connect the bracket that holds the transmission oil cooler to the oil pan.
- Install the seals, flange (5) and tube assembly (4) as shown.
- Make sure seals are in position and connect the flange and tube assembly (6) to the transmission oil cooler.

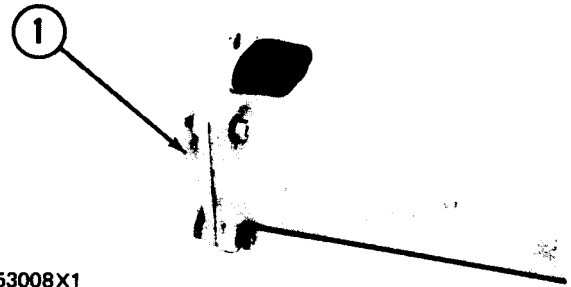

B53008X1

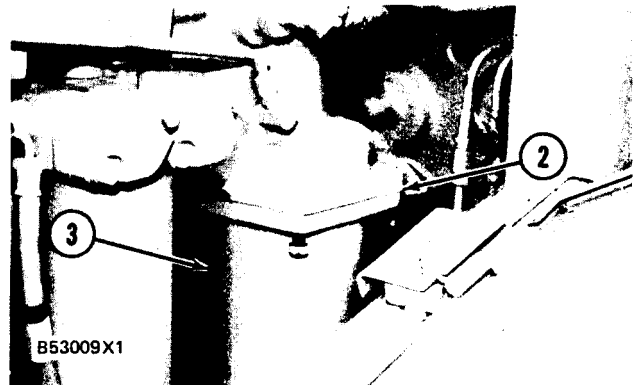

B53009X1

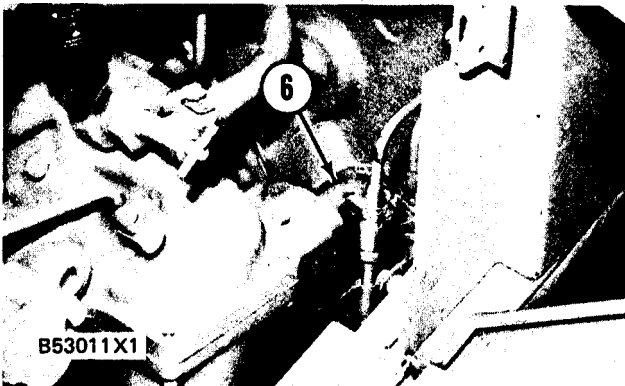

B53011X1

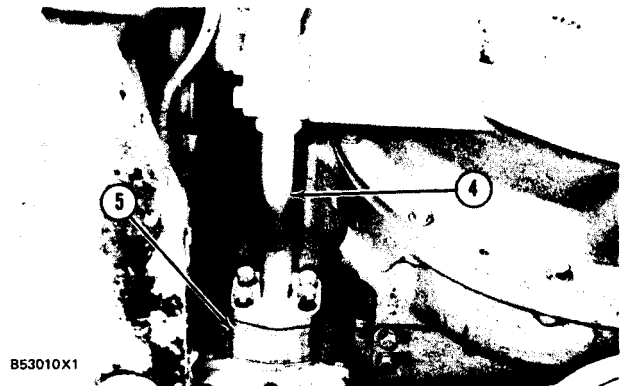

B53010X1

RADIATOR, OIL COOLER AND GUARD

Models 950BNS and 950BS

REMOVE RADIATOR, OIL COOLER AND GUARD 1374 & 1381-11

Tools Needed		A
5P9736	Link Bracket	4

start by:

a) remove hood

1. Drain the coolant from the radiator.
2. Drain the oil from the hydraulic tank.
3. Loosen the clamps and move hoses (1) and (2) down on the lower tube assemblies. If necessary, loosen clamp (3).
4. Loosen the clamps and move hose (4) on to tube (5).
5. Disconnect wire harness (6). Remove the bolt and disconnect the clip and wire (7) from the frame.
6. Loosen the clamps and move hose (9) on to tube (8).
7. Remove the bolt and disconnect clip (10) that holds the battery cables to the guard.

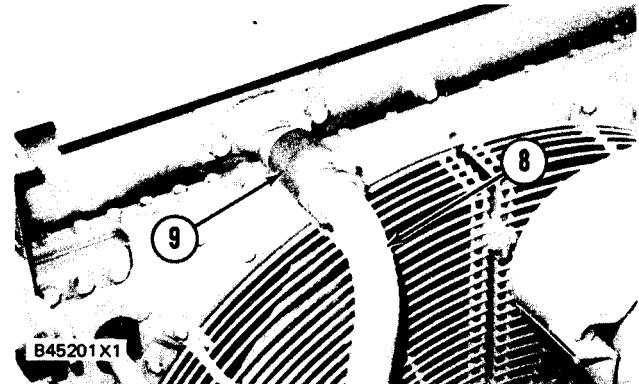
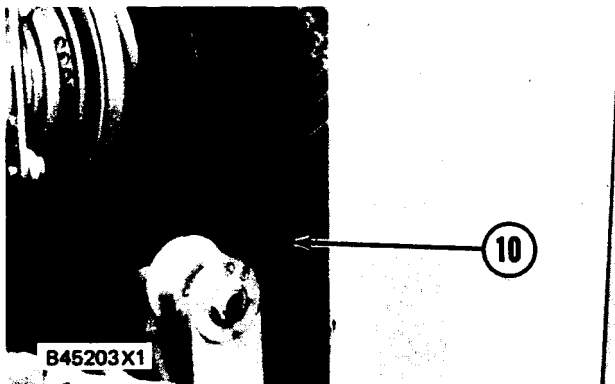
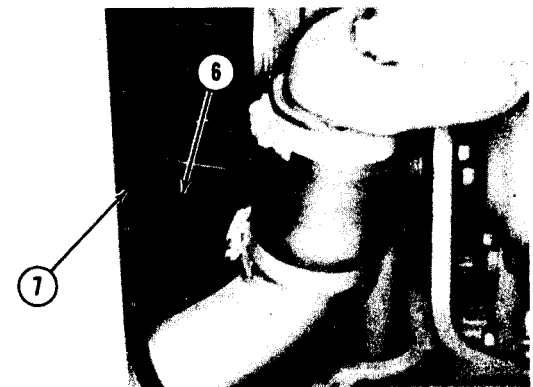
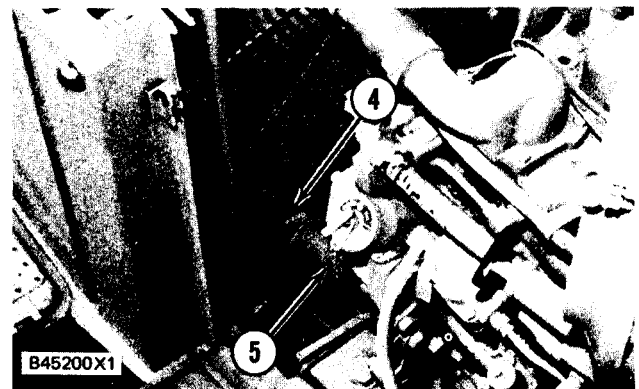
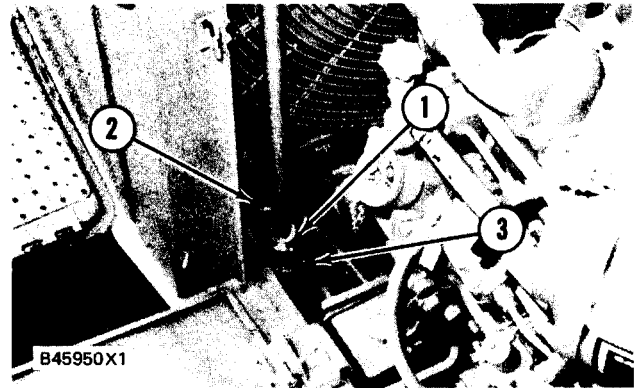

RADIATOR, OIL COOLER AND GUARD

Models 950BNS and 950BS

- Fasten strap (13) and a hoist to fan assembly (11) and remove bolts (12).

CAUTION

Do not damage the radiator core with the fan assembly when fan is disconnected from the fan drive.

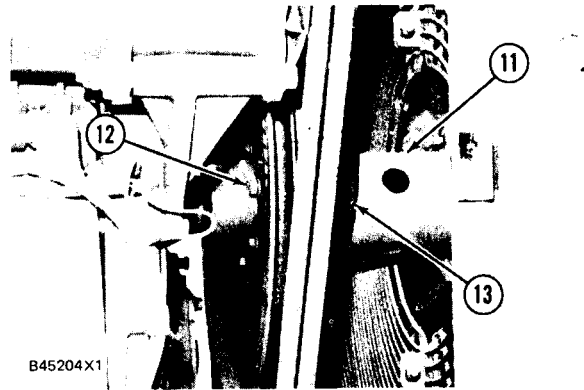

- Carefully lower fan assembly (11) into the radiator guard.

- Fasten strap (14) and a hoist to grille (15). Remove the bolts and grille (15) from the guard. The weight of the grille is 23 kg (50 lb.).

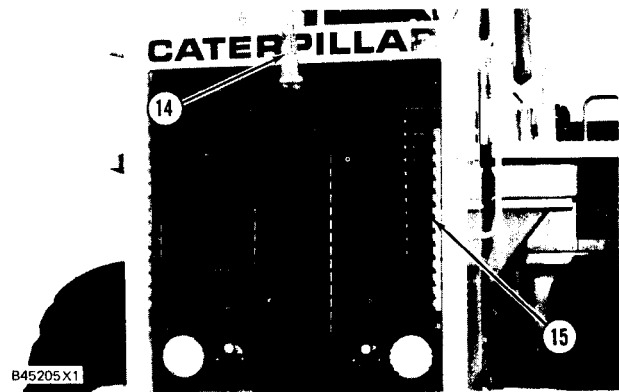

- Fasten tool (A), straps (16) and a hoist to radiator, oil cooler and guard (17) as shown.

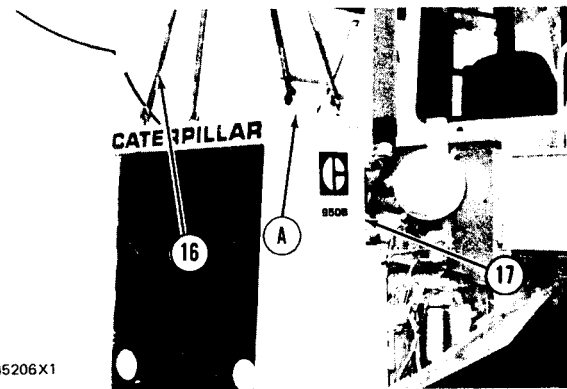

- Remove six bolts (18) that hold the guard to the frame.

NOTE: Two bolts are behind the rear lights.

- Remove radiator, oil cooler and guard (17) from the machine. The weight of the guard assembly is 499 kg (1100 lb.).

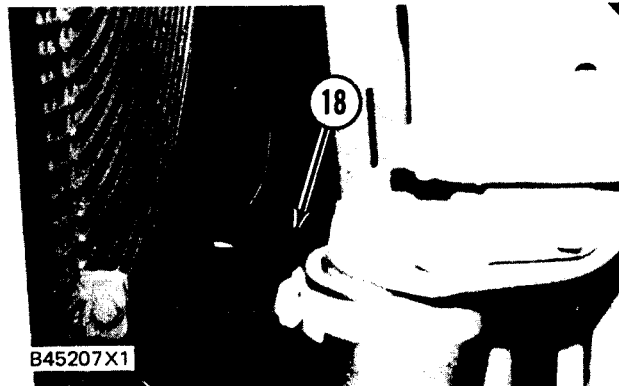
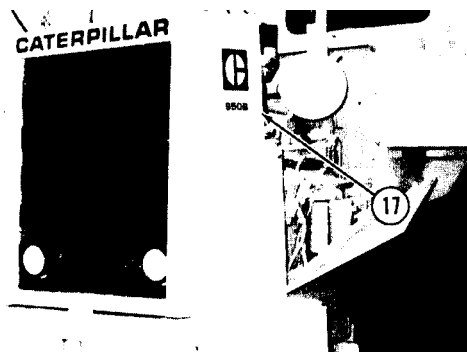

RADIATOR, OIL COOLER AND GUARD

Models 950BNS and 950BS

INSTALL RADIATOR, OIL COOLER AND GUARD 1374 & 1381-12

Tools Needed		A
5P9736	Link Bracket	4

1. Fasten tool (A), straps (1) and hoist to radiator, oil cooler and guard (2) and install on the machine as shown.

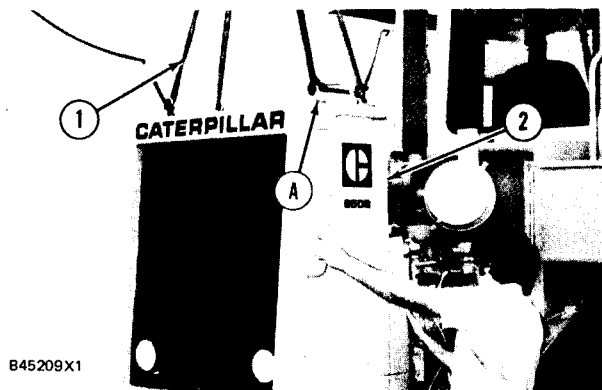

2. Install the six bolts that hold the guard assembly to the machine.

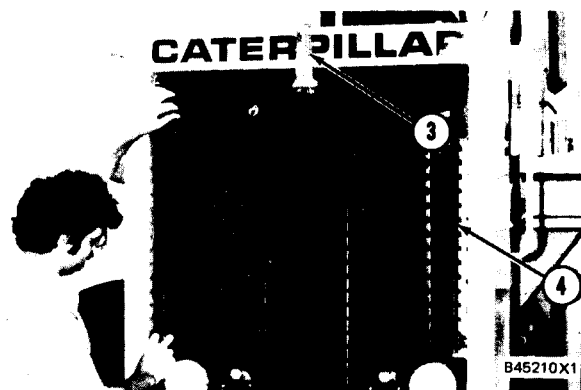

3. Fasten strap (3) and a hoist to grille (4) and install on the guard assembly.

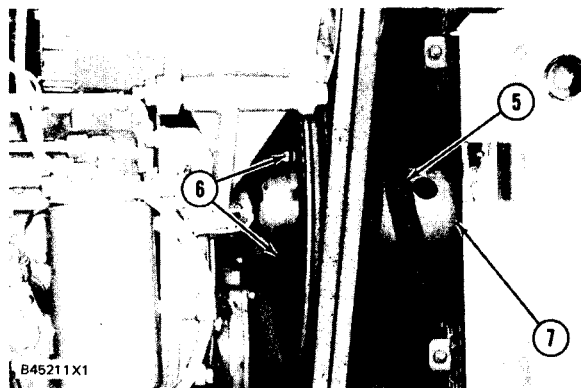

4. Fasten strap (5) and a hoist to fan (7) and put it into position on the fan drive.

5. Install bolts (6) that hold fan (7) to the fan drive.



6. Connect clip (8) that holds the battery cables to the guard assembly.

RADIATOR, OIL COOLER AND GUARD

Models 950BNS and 950BS

7. Connect wire harness (9) and connect the clip that holds wire (10) to the bottom of the guard assembly.

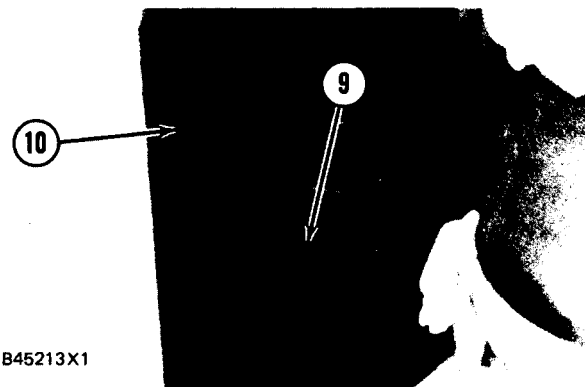

8. Move hose (11) into position on the elbow and tighten the clamps.



9. Move the hoses on to tube assemblies (12) and (13) and tighten the clamps.

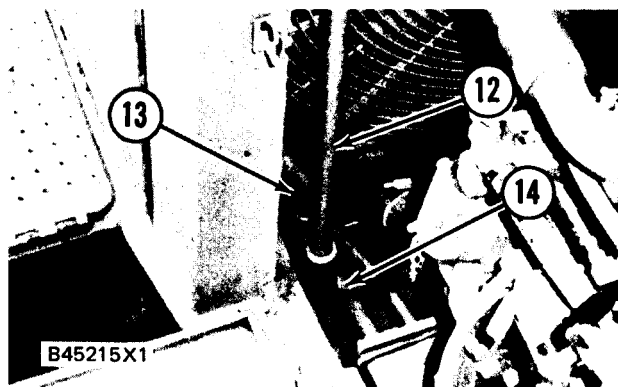

10. Move clamp (14) into position and tighten the bolt.

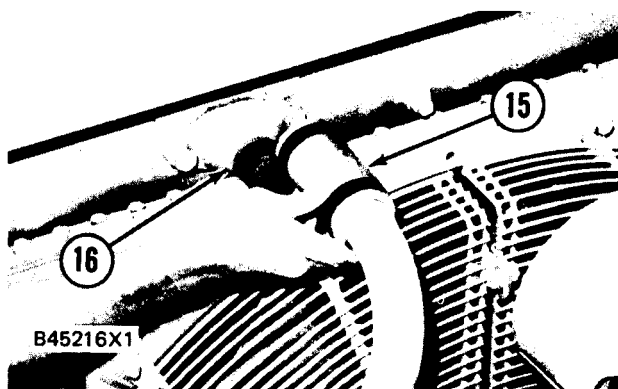

11. Move hose (15) on to pipe (16) and tighten the clamps.
end by:
a) install hood

RADIATOR, OIL COOLER, AND GUARD

Models 950BNSCE, 950BSCE

REMOVE RADIATOR, OIL COOLER AND GUARD

Tools Needed		
5P9736	Link Bracket	1

start by:
Remove hood

1. Drain the coolant from the radiator.
2. Drain the oil from the hydraulic tank.
3. Remove clamps (1) and (2).
4. Slide hoses (3) and (4) from the radiator (5).
5. Remove hoses (6) and (7) at connectors (8).
6. Disconnect wiring harness for any lighting installed on radiator guard.

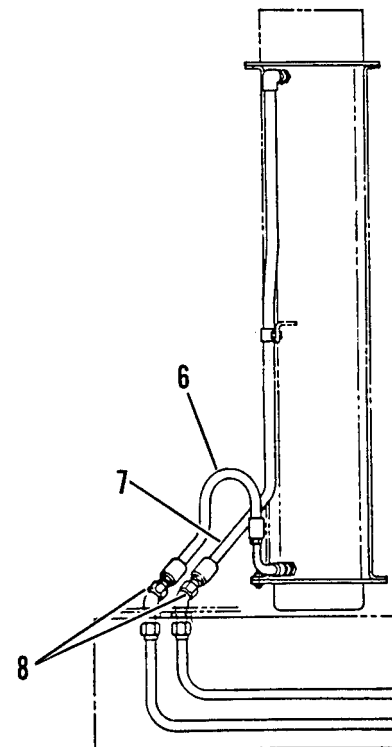
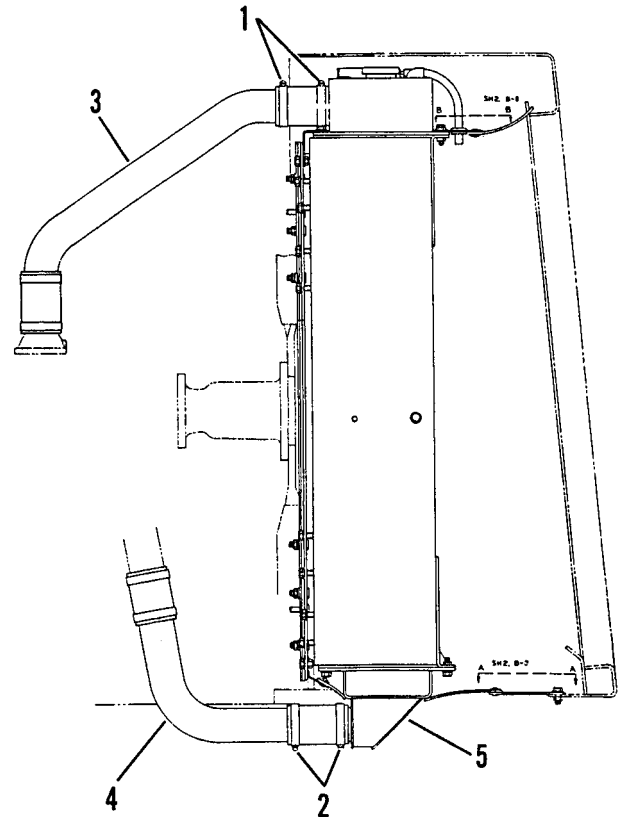

ENGINE

RADIATOR, OIL COOLER, AND GUARD Models 950BNSCE, 950BSCE

7. Remove the bolt and disconnect clip (9) that holds the battery cables to the guard.

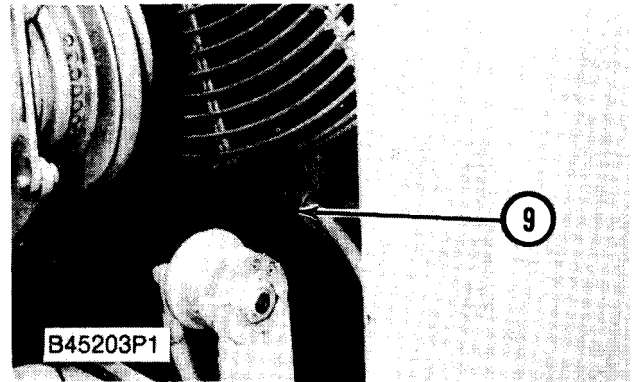

8. Fasten strap (10) and a hoist to fan assembly (11) and remove bolts (12).

CAUTION

Do not damage the radiator core with the fan assembly when fan is disconnected from the fan drive.

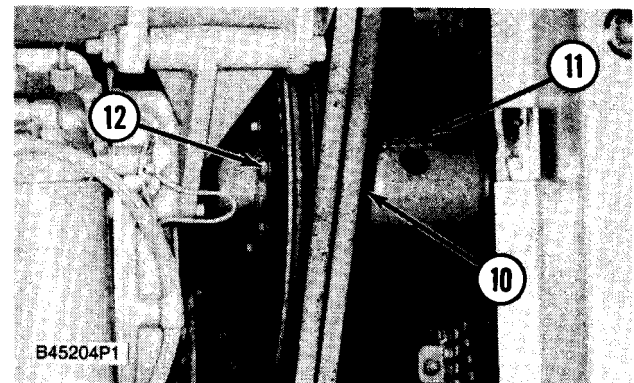

9. Carefully lower fan assembly (11) into the radiator guard.

10. Fasten a strap and a hoist to grille (13). Remove bolts (14) and grille from the guard. The weight of the grille is 25 kg (55 lb.).

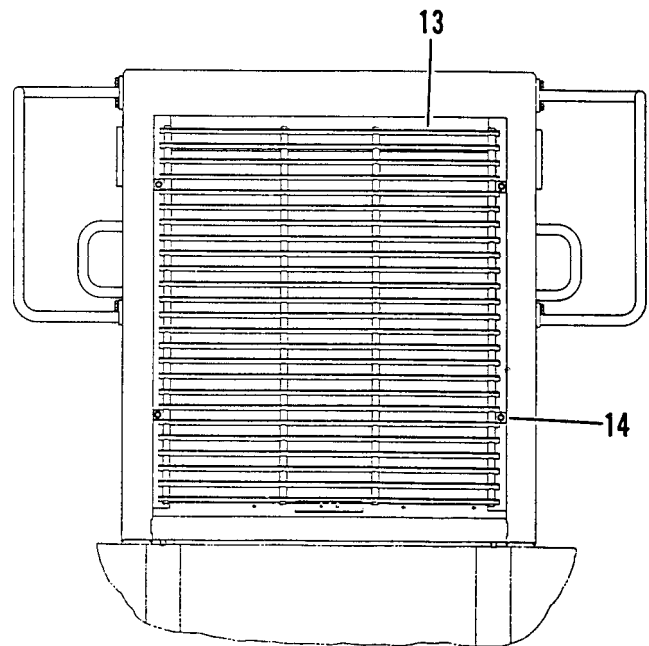

RADIATOR, OIL COOLER, AND GUARD Models 950 BNSCE, 950BSCE

11. Fasten tool (A), straps (15) and a hoist to radiator, oil cooler and guard (16) as shown.
12. Remove bolts that secure the guard to the frame.
13. Remove radiator, oil cooler and guard from the machine. The weight of the guard assembly is approximately 499 kg (1100 lb.).

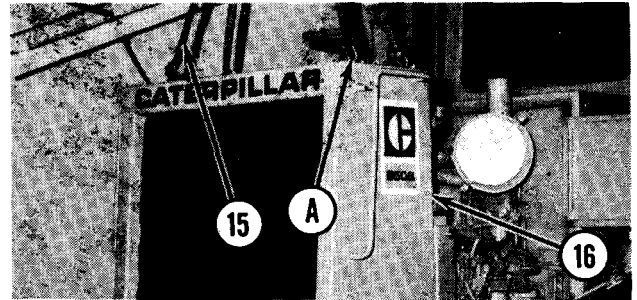

INSTALL RADIATOR, OIL COOLER AND GUARD

Tools Needed		
	Tools Needed	A
5P9736	Link Bracket	1

1. Fasten tool (A), straps (15) and a hoist to radiator, oil cooler and guard (16) as shown.
2. Install radiator, oil cooler and guard onto the machine. The weight of the guard assembly is approximately 499 kg (1100 lb.).
3. Install bolts that secure the guard to the frame.
4. Fasten a strap and a hoist to grille (13). Install bolts (14) and grille onto the guard. The weight of the grille is 25 kg (55 lb.).

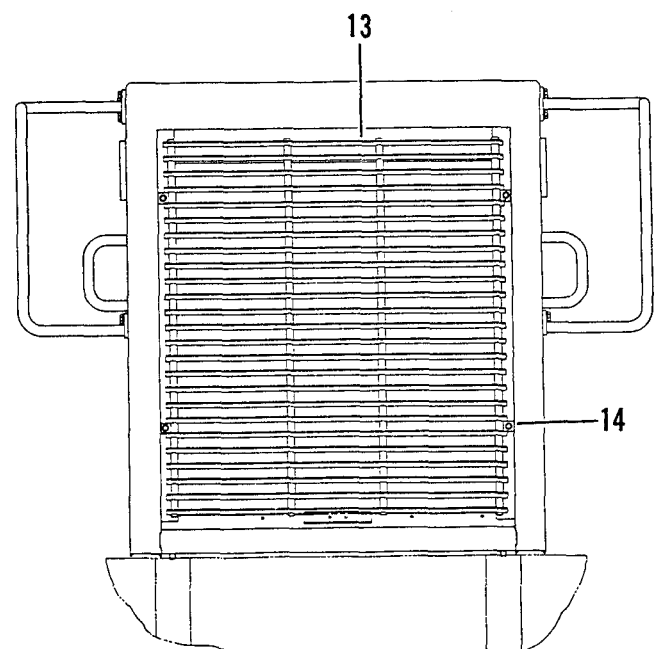
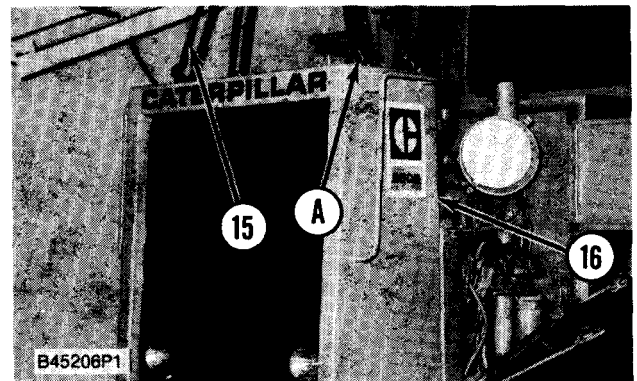

RADIATOR, OIL COOLER, AND GUARD Models 950BNSCE, 950BSCE

5. Fasten strap (10) and a hoist to fan assembly (11).
6. Carefully raise fan assembly (11) onto fan drive and install bolts (12).

CAUTION

Do not damage the radiator core with the fan assembly when fan is mounted onto the fan drive.

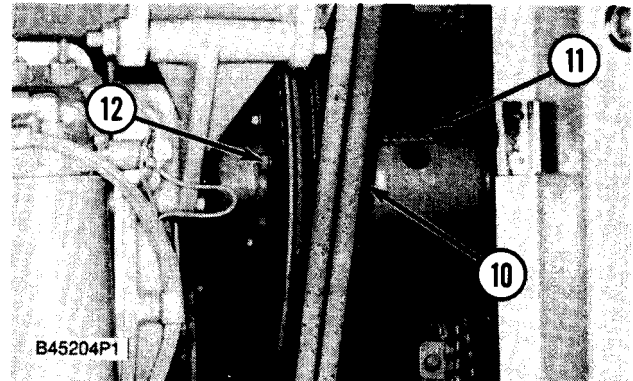

7. Install the bolt and clip (9) that secure battery cables to guard.
8. Connect wiring harness for any lighting installed on radiator guard.

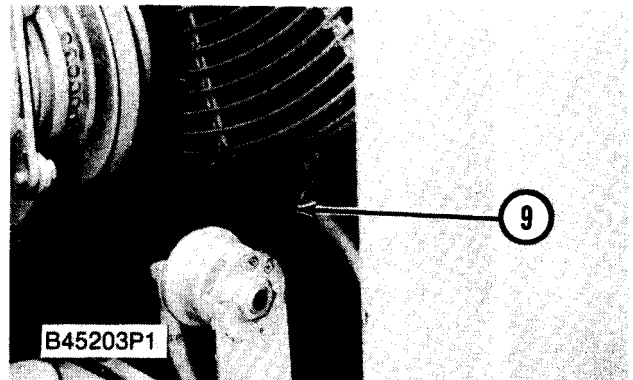

9. Install hoses (6) and (7) at connectors (8).

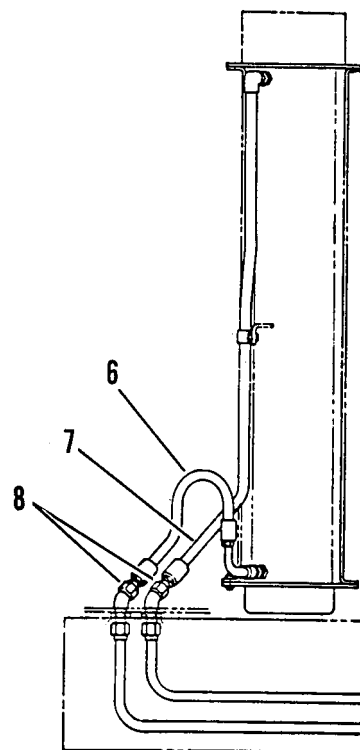

RADIATOR, OIL COOLER, AND GUARD Models 950BNSCE, 950BSCE

10. Slide hoses (3) and (4) onto the radiator (5).
11. Install clamps (1) and (2).
12. Fill the hydraulic system with the proper amount of hydraulic fluid and check for leaks.
13. Fill the radiator with the proper amount of coolant and check for leaks in the system.

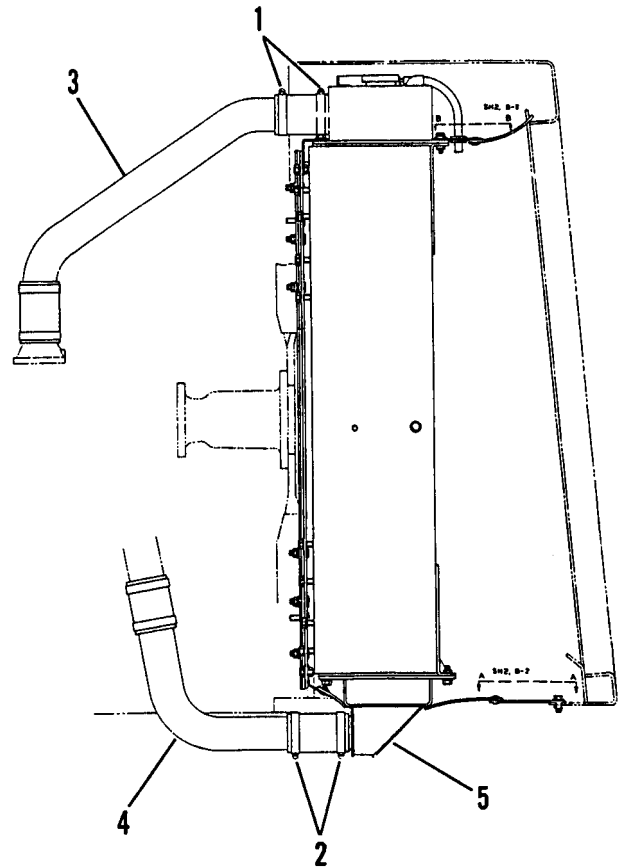

RADIATOR AND HYDRAULIC OIL COOLER

COOLER

1353 & 1374-11

Tools Needed	A
OTC Model 1790 Transmission Jack	1

1. Drain the coolant from the radiator.
2. Fasten a strap and hoist to grille (1) as shown.
3. Remove the bolts and grille (1) from the radiator guard. The weight of the grille is 25 kg (55 lb.).
4. Put tool (A) in position under guard (2) as shown.
5. Remove the bolts and guard (2) from the machine. The weight of the guard is 32 kg (70 lb.).
6. Remove the bolts and plate (3) from the radiator guard.
7. Remove the bolts and disconnect tube assembly (4) from the hydraulic oil cooler.
8. Remove tube nuts, the screw and side panel (5) from the radiator guard.

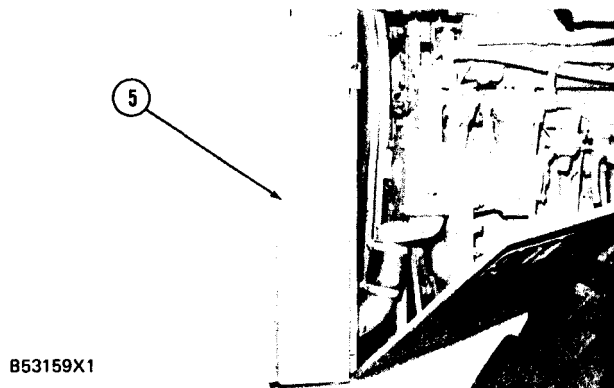
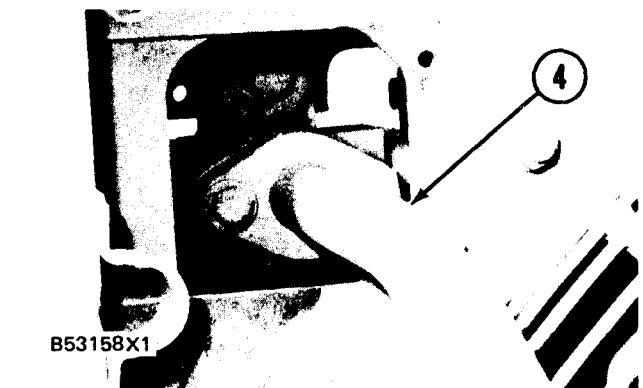
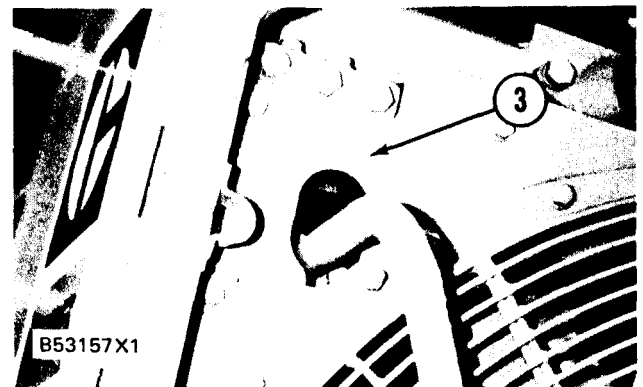
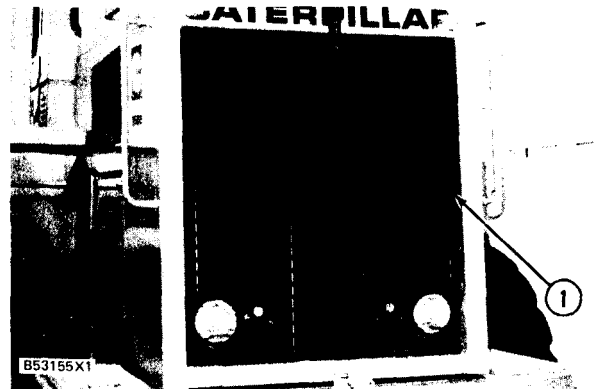

ENGINE

RADIATOR AND HYDRAULIC OIL COOLER

Models 950BNS and 950BS

9. Remove the bolts and plate (6) from the radiator guard.

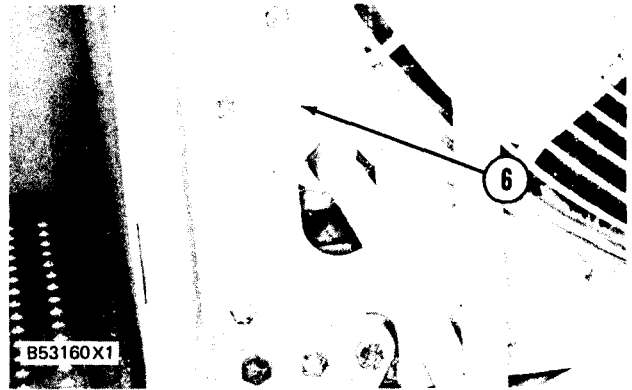

10. Remove the bolts and disconnect tube assembly (7) from the hydraulic oil cooler.

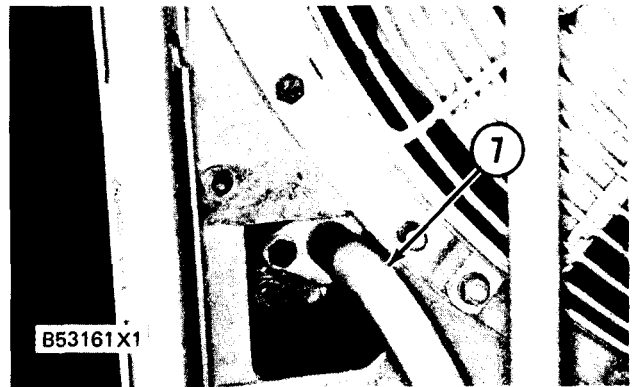

NOTE: There will be some oil loss when tube assembly (7) is disconnected.

11. Loosen hose clamps (8) and remove tube assemblies (4) and (7) from the machine.

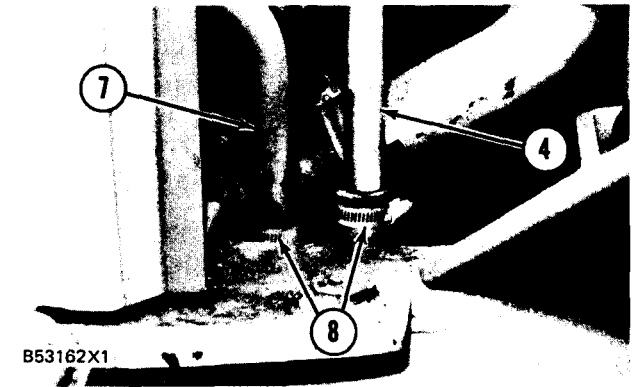

12. Put caps or plugs in the ends of the hoses to prevent oil loss.

13. Remove the bolts and disconnect elbow (9) from the top of the radiator assembly.

14. Remove the bolts and disconnect elbow (10) from the bottom of the radiator assembly.

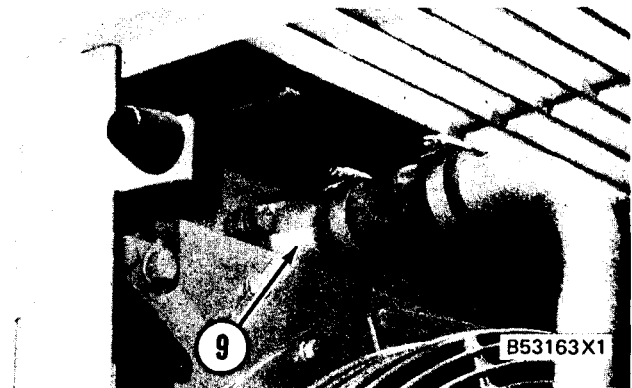
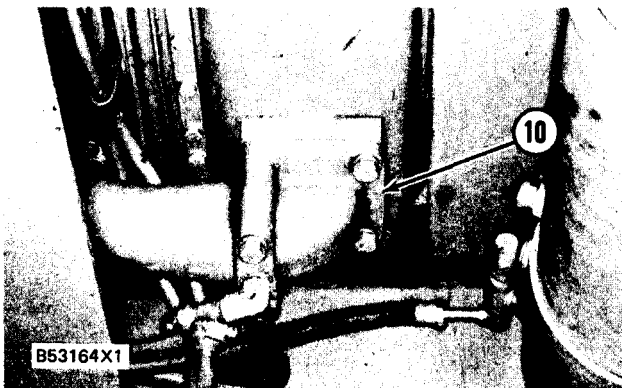

ENGINE

RADIATOR AND HYDRAULIC OIL COOLER

Models 950BNS and 950BS

15. Remove the bolts and panel (11) from the radiator guard.

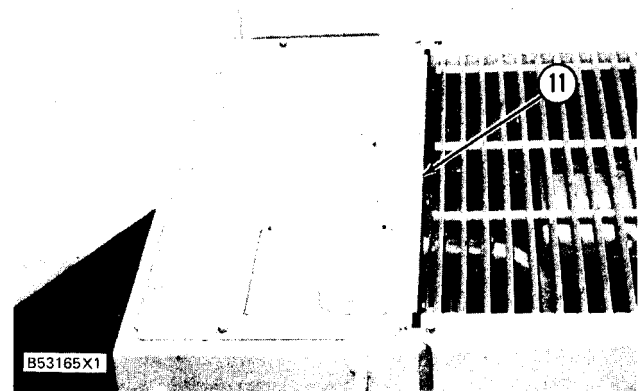

16. Loosen the bolts and nuts (12) and slide panel (13) away from the radiator assembly.

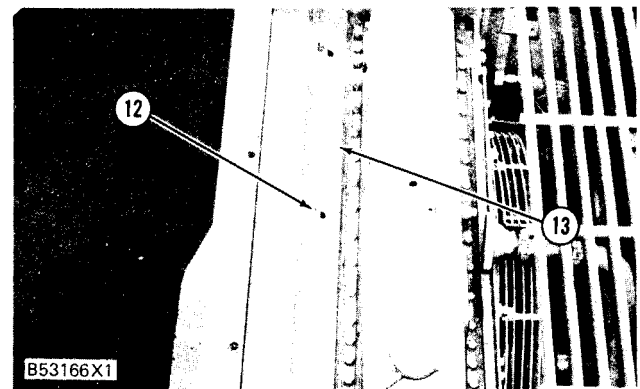

17. Install a 5/8"-11 NC forged eyebolt (15) and a hoist on radiator assembly (16) as shown.

18. Remove bolts (14) from the four corners of the radiator guard.

19. Make sure strips (17) both top and bottom are pulled away from radiator assembly (16).

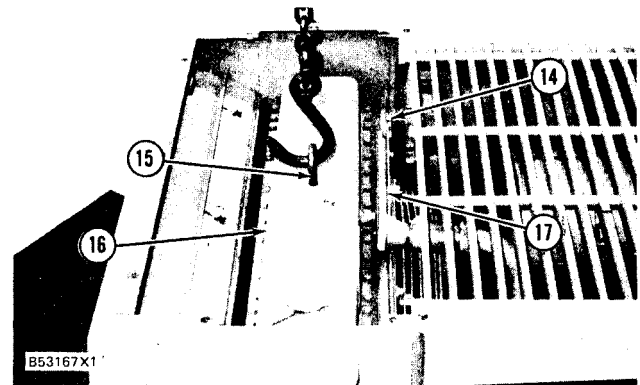

20. Remove radiator assembly (16) from the machine. The weight of the radiator assembly is 197 kg (435 lb.).

21. Put the radiator assembly on blocks as shown.

22. Remove the bolts and guard (18) from the radiator assembly.

23. Remove bolts (21) and the bracket from the radiator assembly.

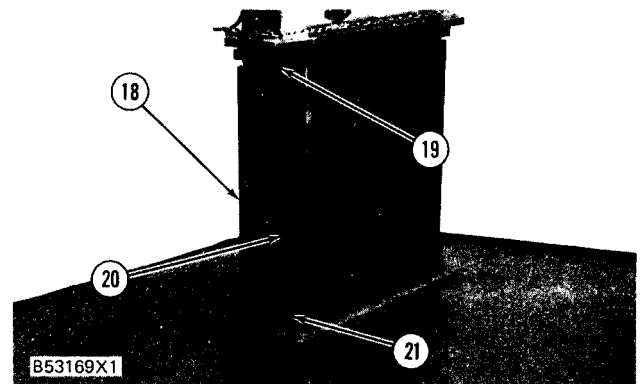

24. Remove bolt (19) and hydraulic oil cooler (20) from the radiator assembly. The weight of the hydraulic oil cooler is 23 kg (50 lb.).

ENGINE

RADIATOR AND HYDRAULIC OIL COOLER

Models 950BNS and 950BS

INSTALL RADIATOR AND HYDRAULIC OIL COOLER 1353 & 1374-12

Tools Needed	A
OTC Model 1790 Transmission Jack	1

1. Put hydraulic oil cooler (3) in position on the radiator assembly and install bolt (1) and bracket (4) that hold it.

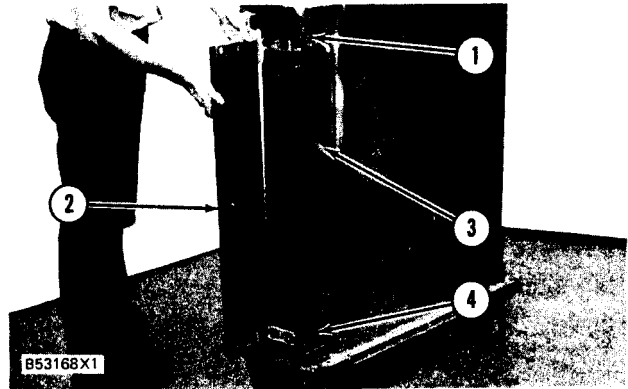

2. Install guard (2) on the radiator assembly as shown.

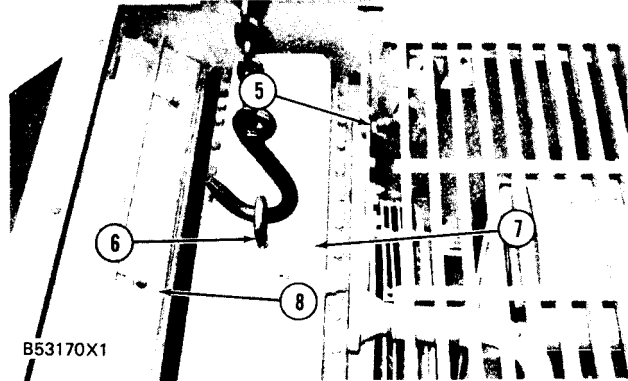

3. Install 5/8"-11 NC forged eyebolt (6) and a hoist on radiator assembly (7) as shown.

4. Put radiator assembly (7) in position in the radiator guard and install bolts (5) in the four corners to hold it in place.

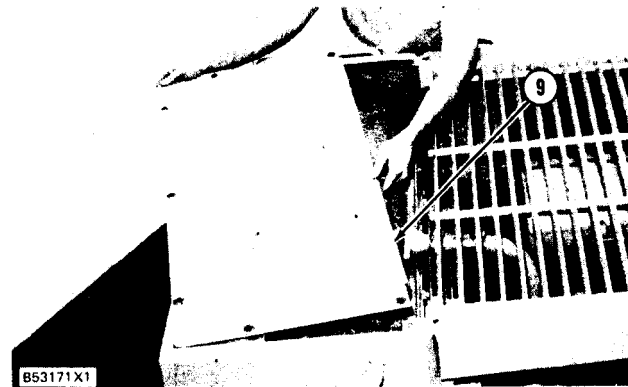

5. Move plate (8) against the radiator assembly and tighten the bolts and nuts.

6. Install plate (9) on the radiator guard.

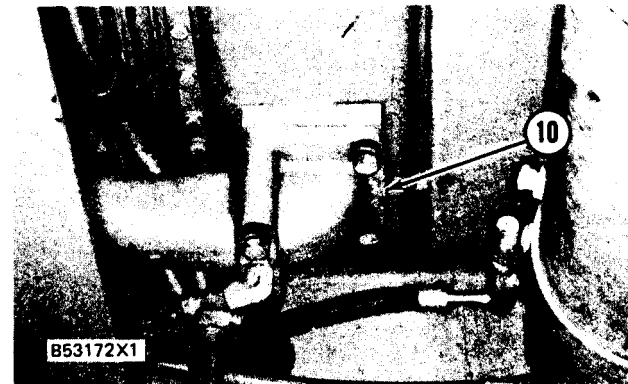

7. Make sure the gasket is in position and connect elbow (10) to the bottom of the radiator.

RADIATOR AND HYDRAULIC OIL

Models 950BNS and 950BS

8. Make sure the gasket is in position and connect elbow (11) to the radiator.

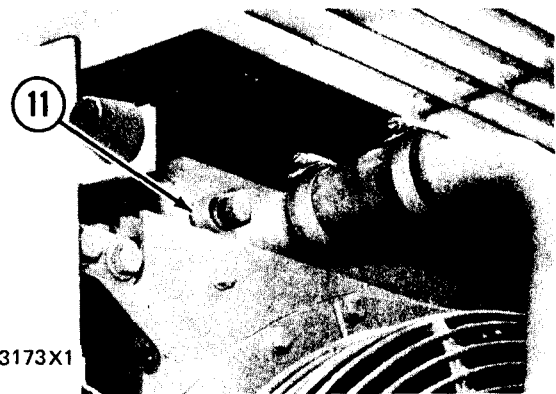

B53173X1

9. Install tube assemblies (12) and (13) in the hoses and tighten the clamps.

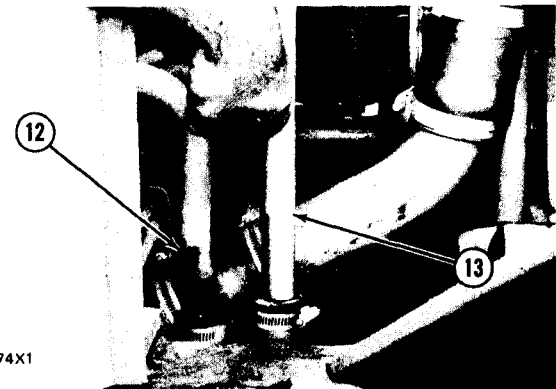

B53174X1

10. Put the O-ring seal in position on tube assembly (12) and connect it to the hydraulic oil cooler.

11. Install plate (14) on the radiator guard.

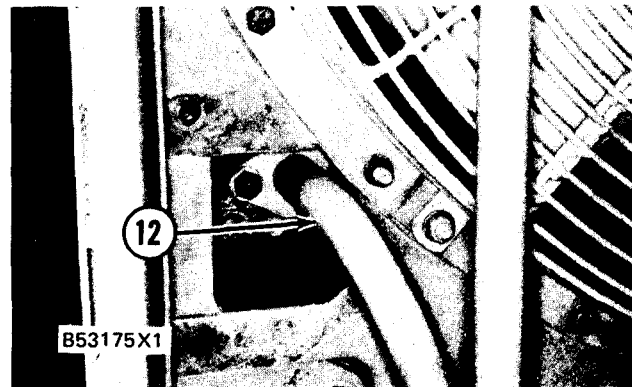

B53175X1

12. Install side panel (15) on the radiator guard as shown.



B53176X1

RADIATOR AND HYDRAULIC OIL COOLER

Models 950BNS and 950BS

13. Put the O-ring seal in position on tube assembly (13) and connect it on the hydraulic oil cooler.

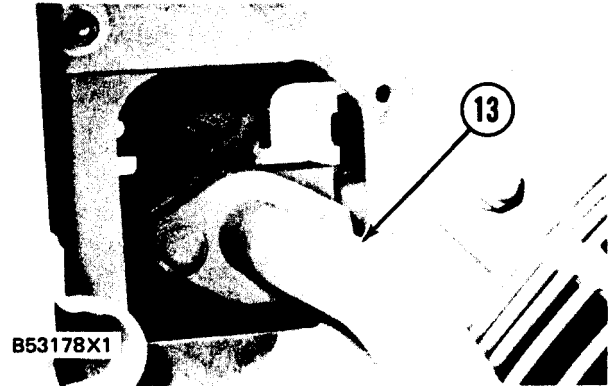

14. Install plate (16) on the radiator guard.



15. Use tool (A) and install guard (17) to the bottom of the machine.

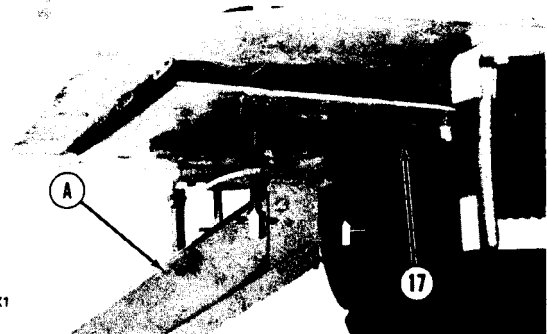

16. Fasten a strap and hoist to grille (18) and install it on the radiator guard as shown.



17. Fill the radiator with coolant.

RADIATOR AND HYDRAULIC OIL COOLER

Models 950BNSCE and 950BSCE

REMOVE RADIATOR AND HYDRAULIC OIL COOLER

Tools Needed	A
OTC Model 1790 Trans. Jack	1

1. Drain the coolant from the radiator.
2. Fasten a strap and hoist to grill (1).
3. Remove the bolts and grill (1) from the radiator guard. The weight of the grill is 30 kg (66 lb.).
4. Remove hydraulic oil cooler lines at couplings (2). Remove clamp (3). Remove oil cooler lines (4) and (5) from radiator and guard.

NOTE: One of the cores of the radiator is used as a hydraulic oil cooler and is not part of the engine cooling system.

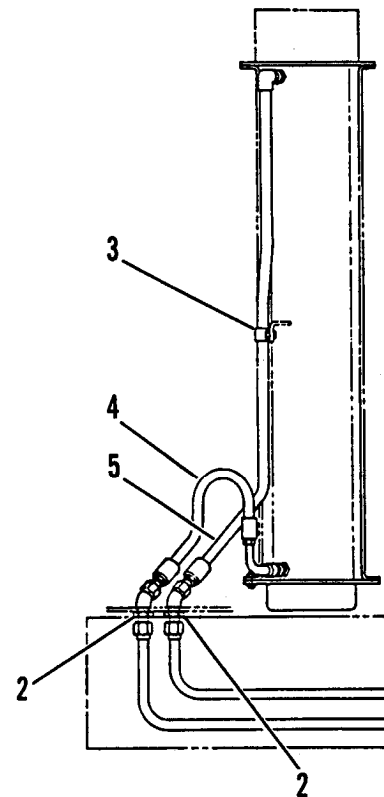
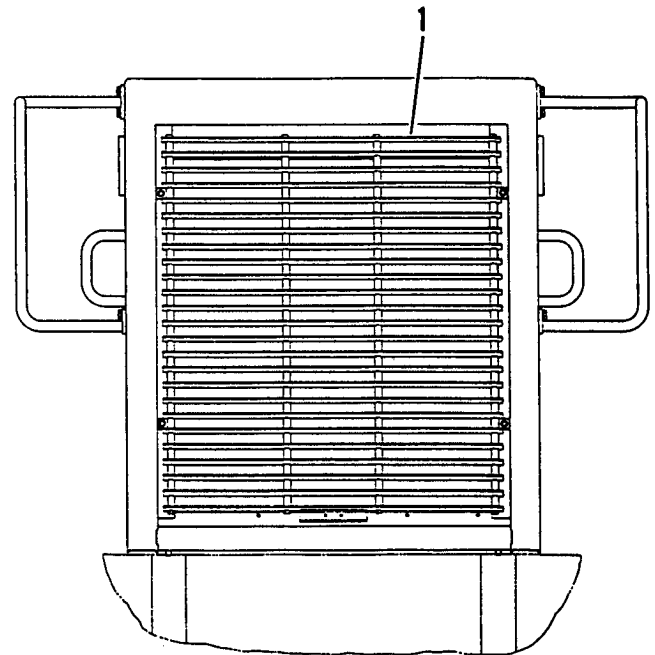

ENGINE

RADIATOR AND HYDRAULIC OIL COOLER Models 950BNSCE and 950BSCE

5. Put tool (A) in position under guard (6) as shown.
6. Remove the bolts and guard (6) from the machine. The weight of the guard is 40 kg (88 lb.).



7. Remove side panel (7) from the radiator guard.

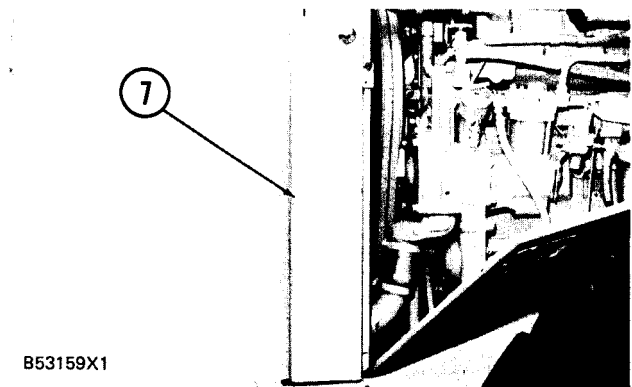

8. Remove bolts and panel (8) from top of radiator guard.

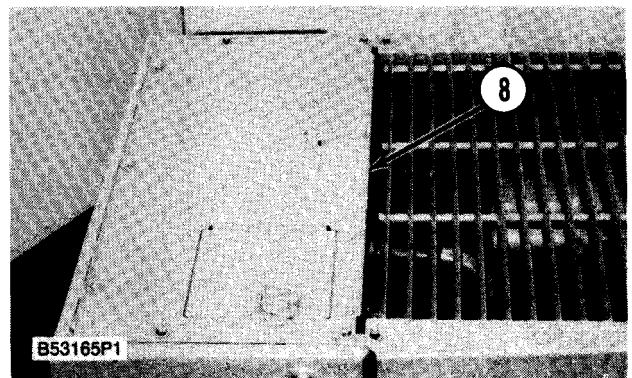

RADIATOR AND HYDRAULIC OIL COOLER Models 950BNSCE and 950BSCE

9. Loosen clamps (9) and (10) from hose (11) and remove hose (11) from machine.
10. Loosen clamps (12) and (13) from hose (14) and remove hose (14) from machine.

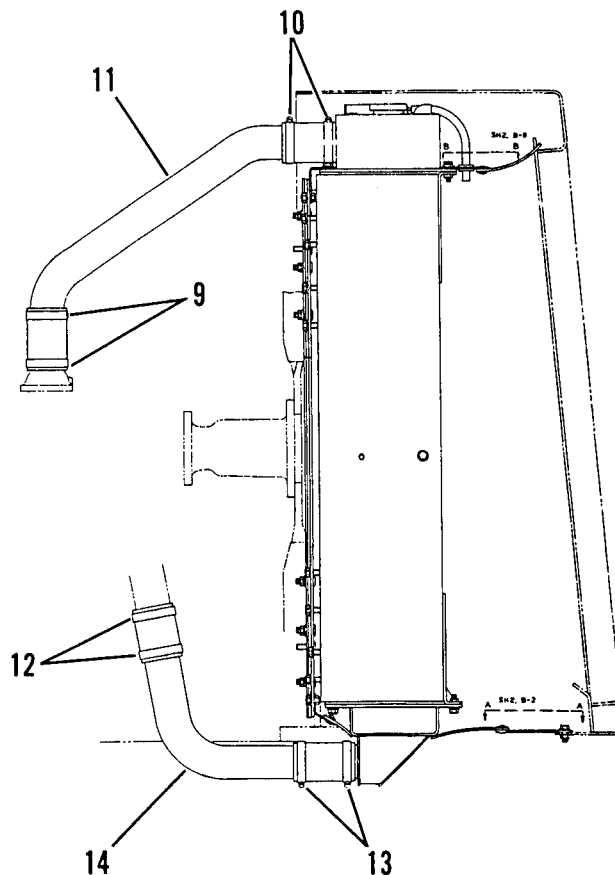

11. Loosen bolts and nuts (15) and slide panel (16) away from the radiator assembly.

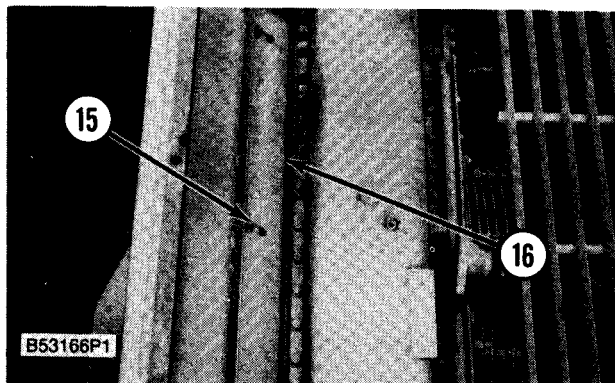

12. Install a 5/8" - 11 NC forged eyebolt (17) and a hoist on radiator assembly (18) as shown.

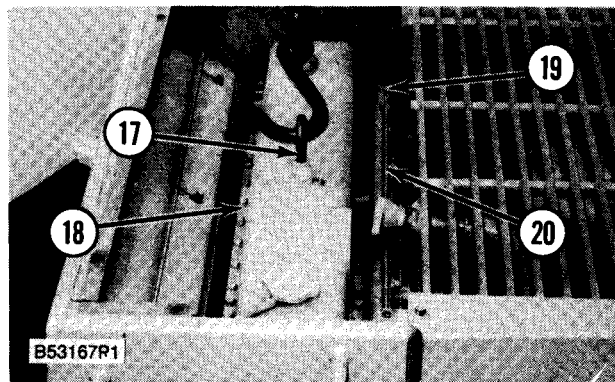

13. Remove bolts (19) from the four corners of the radiator.
14. Make sure strips (20) both bottom and top are pulled away from radiator assembly (18).
15. Remove radiator assembly (18) from the machine. The weight of the radiator assembly is approximately 225 kg (500 lb.).
16. Place radiator assembly on blocks for disassembly.

ENGINE

RADIATOR AND HYDRAULIC OIL COOLER

Models 950 BNSCE and 950BSCE

INSTALL RADIATOR AND HYDRAULIC OIL COOLER

Tools Needed	A
OTC Model 1790 Trans. Jack	1

1. Install a 5/8" - 11 NC forged eyebolt (17) and a hoist on radiator assembly (18) as shown.
2. Install radiator assembly (18) onto the machine. The weight of the radiator assembly is approximately 225 kg (500 lb.).
3. Make sure strips (20) both bottom and top are in position on radiator assembly (18).
4. Install bolts (19) onto the four corners of the radiator.
5. Slide panel (16) onto the radiator assembly. Install bolts and nuts (15).
6. Install hose (14) onto machine and tighten clamps (12) and (13).
7. Install hose (11) onto machine and tighten clamps (9) and (10).

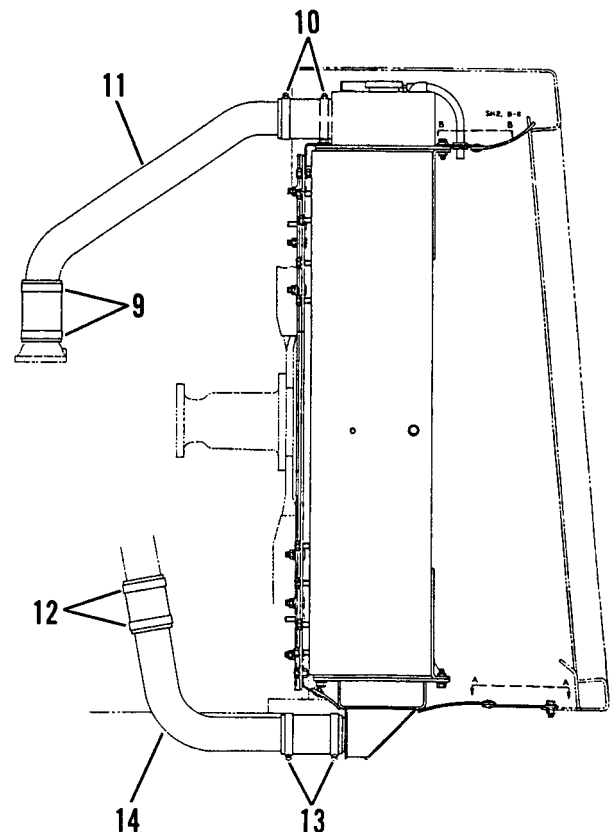
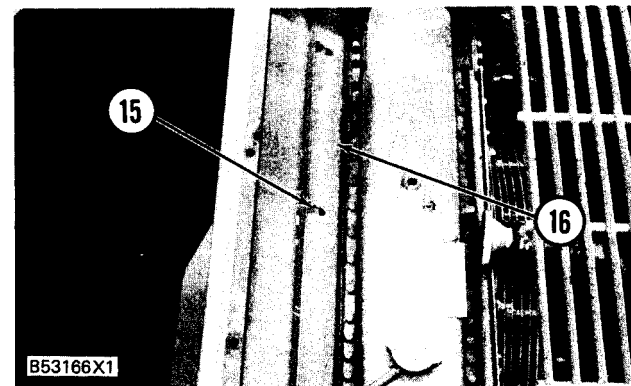
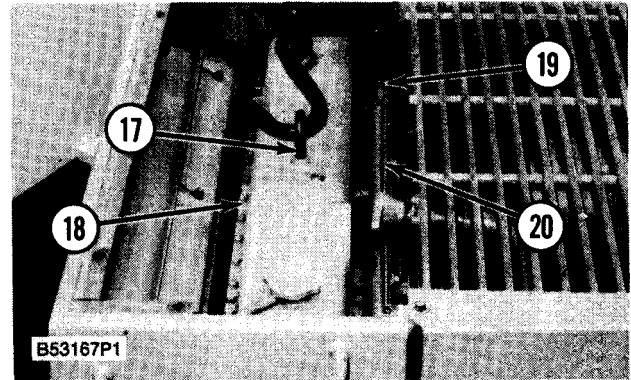

RADIATOR AND HYDRAULIC OIL COOLER

Models 950BNSCE and 950BSCE

8. Place panel (8) into position on top of radiator guard and install bolts.

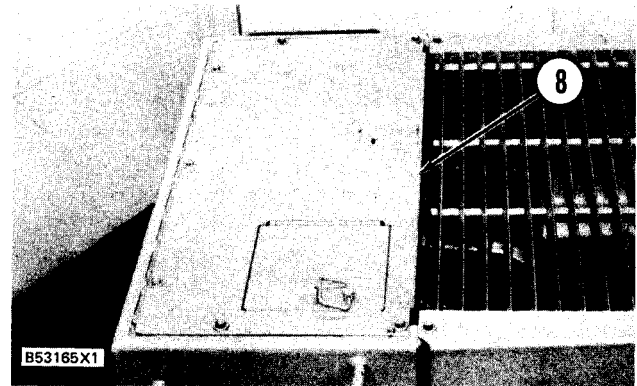

9. Install side panel (7) onto the radiator guard.

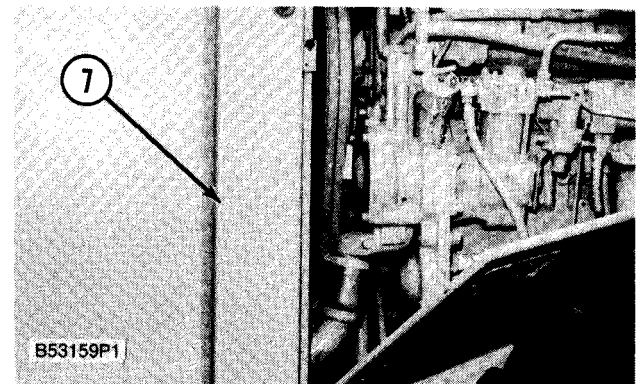

10. Place tool (A) in position under guard (6) as shown.
11. Raise guard into position and secure guard (6) with bolts to the machine. The weight of the guard is 40 kg (88 lb.).

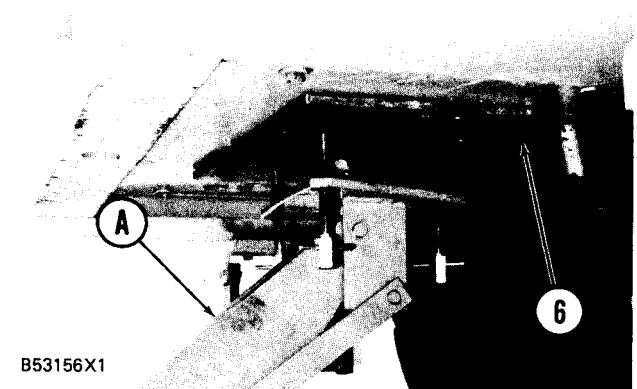

ENGINE

RADIATOR AND HYDRAULIC OIL COOLER

Models 950BNSCE and 950BSCE

12. Install hydraulic oil cooler lines at couplings (2). Install clamp (3). Install oil cooler lines (4) and (5) onto radiator and guard.

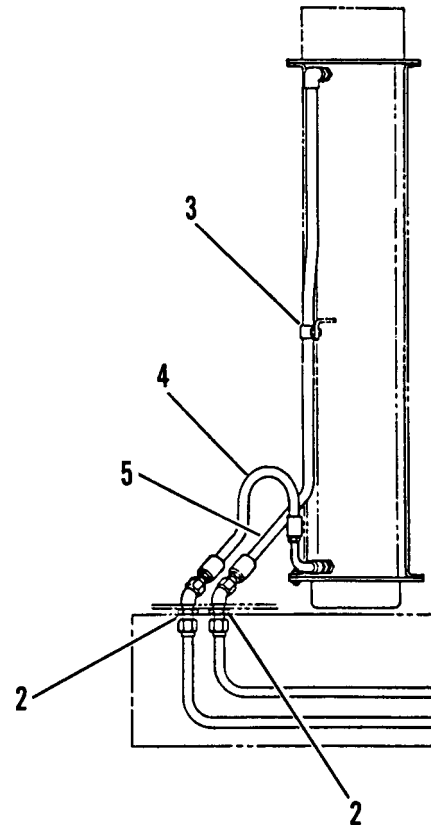

13. Lift grill (1) into position with strap and hoist and secure with bolts to the radiator guard. The weight of the grill is 30 kg (66 lb.).

14. Add coolant to the radiator.

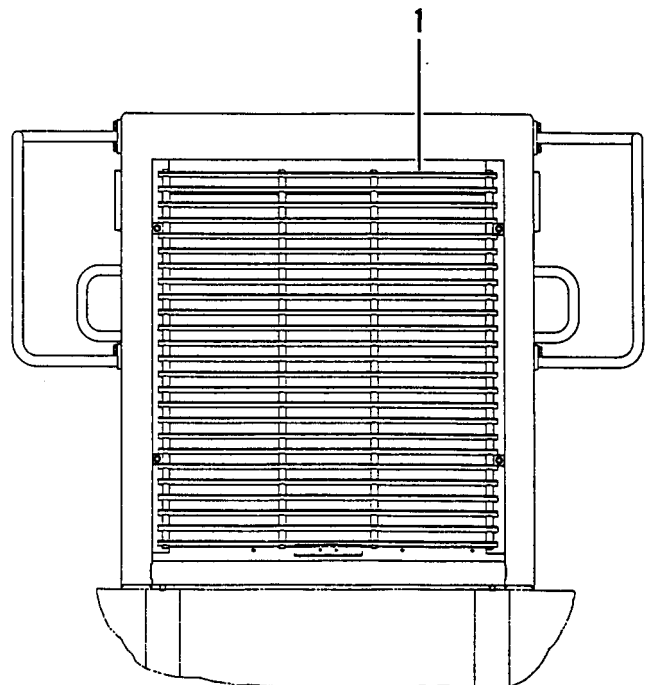

DISASSEMBLY AND ASSEMBLY

RADIATOR AND HYDRAULIC OIL COOLER

Models 950BNSCE and 950BSCE

DISASSEMBLE RADIATOR AND HYDRAULIC OIL COOLER

1. Remove bolts (1) that secure strip (2) to shield assembly (3).
2. Remove bolts (4) that secure shield assembly (3) to radiator.

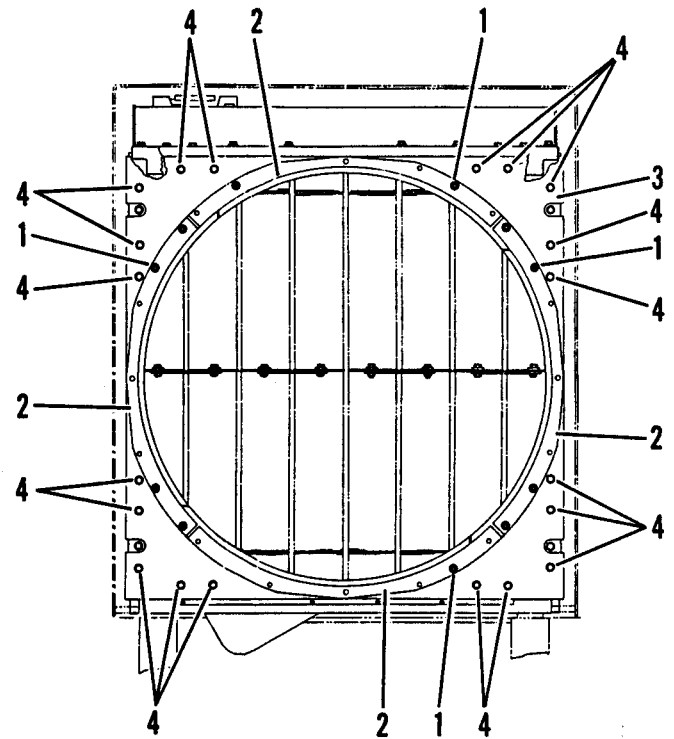

3. Remove baffle assemblies (5) and (6).

NOTE: The radiator assembly used in the following illustrations has 12 cores instead of 8 and should only be used as a guide for disassembly of your radiator.

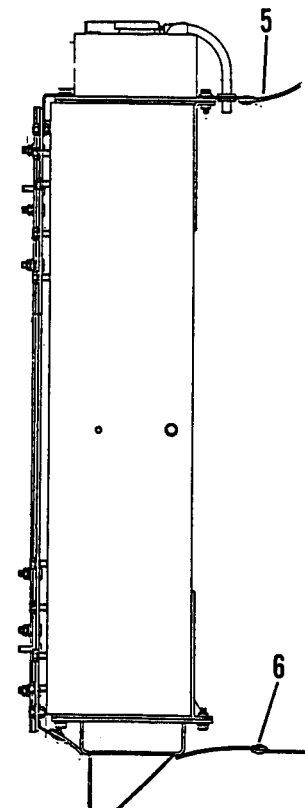

ENGINE

RADIATOR AND HYDRAULIC OIL COOLER Models 950BNSCE and 950BSCE

4. Remove twelve bolts (7) that hold the channels to the top tank. Remove top tank and the seals.



5. Remove bolt (8) from each side that holds the bracket for the outside cores in place.
6. Remove straps (9) that hold cores (10) together.

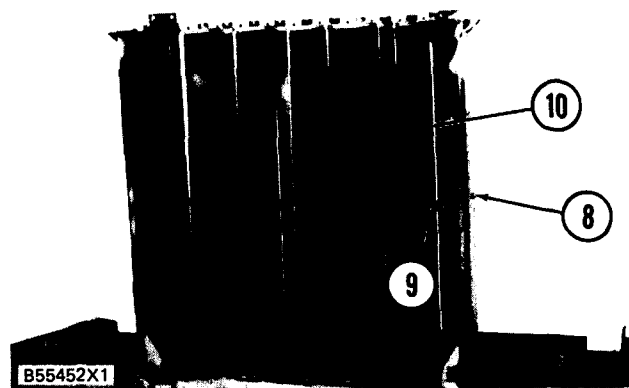

7. Remove cores from the bottom tank (11).
8. Remove seals (12) from the bottom tank (11).

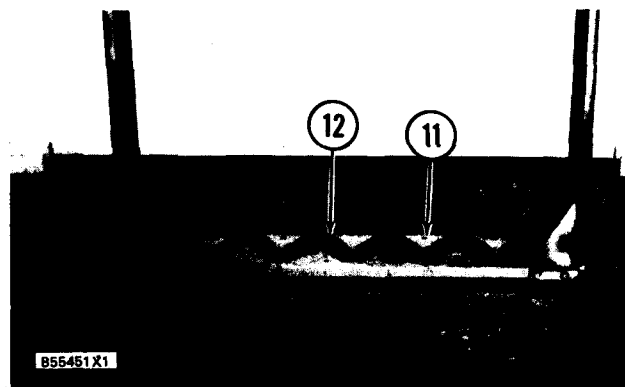

9. Remove bolts (13) and channels (14) and (15) from the bottom tank (11).

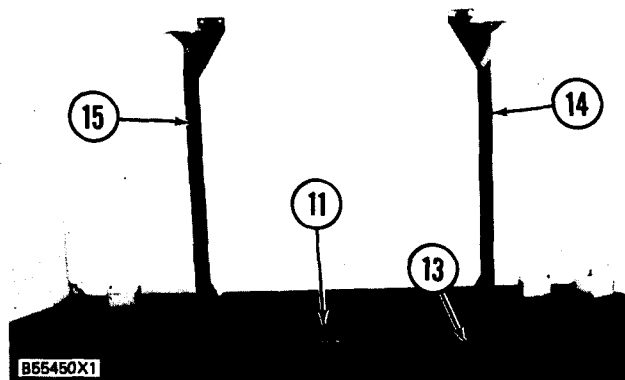

RADIATOR AND HYDRAULIC OIL COOLER

Models 950BNSCE and 950BSCE

10. Inspect seal strips (16) in the channels. If necessary remove the bracket that holds the seal strip in place and remove seal strip (16) from each channel.

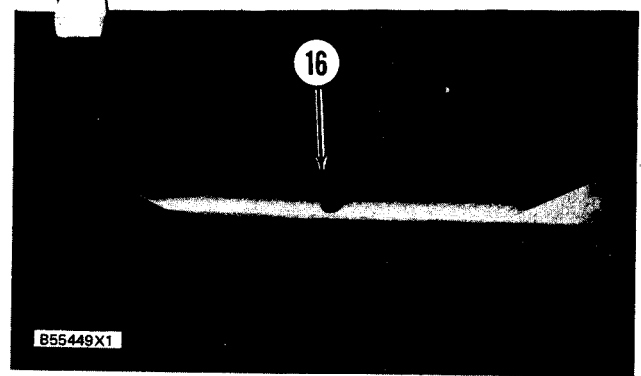

ENGINE

RADIATOR AND HYDRAULIC OIL COOLER

Models 950BNSCE and 950BSCE

ASSEMBLE RADIATOR

1. Place bottom tank (1) in position on wooden blocks as shown.

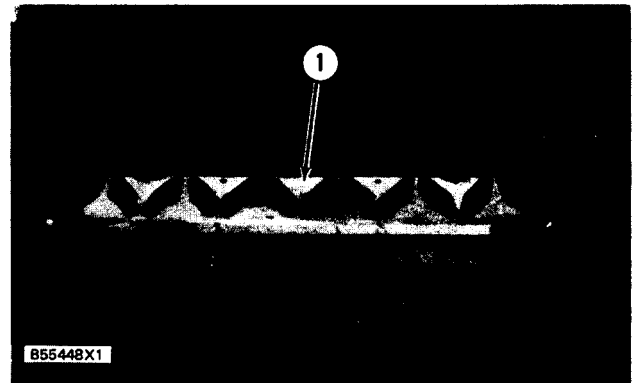

2. If a replacement was necessary, put a seal strip (2) that is 42.13 in. (107 cm) long in position in each channel with the side that has adhesive on it down. Install the bracket that holds the seal strips in place in the channels. The seal strips go toward the back of the radiator.

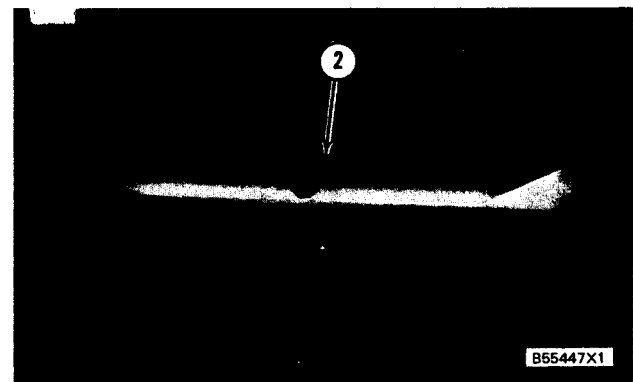

3. Install channels (3) and (4) on the bottom tank. Make sure the seal strips in the channel are toward the back of the radiator.

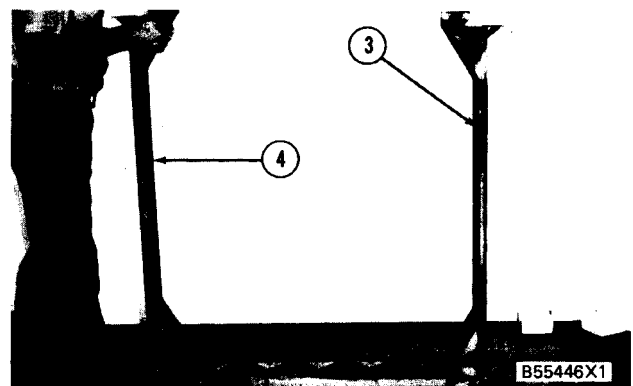

4. Make sure the holes in the bottom tank are clean. Put liquid soap on the sealing areas and install seals (5) on the bottom tank.

NOTE: Put the liquid soap on the seals just before assembly.

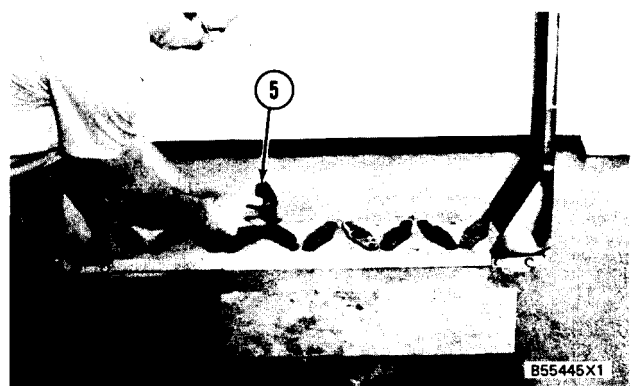

RADIATOR AND HYDRAULIC OIL COOLER Models 950BNSCE and 950BSCE

- Put liquid soap inside the holes of seals (5). Install bracket (6) to each of the end cores. Do not tighten the bolts. Install core (7) and install the bolt that holds bracket (6) to the channel.

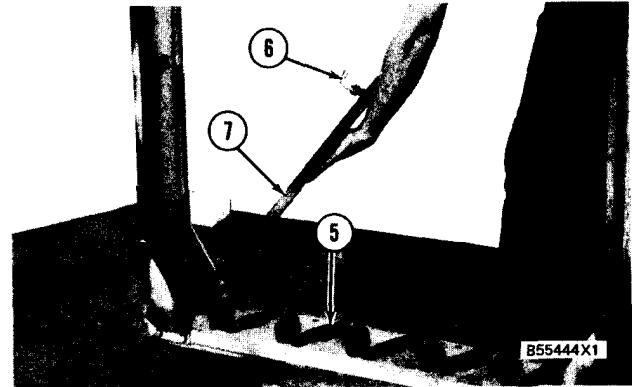

- Install the next core (7) with the bevels together as shown.
- Install strap (8) that holds the cores together. Do not tighten the bolts.

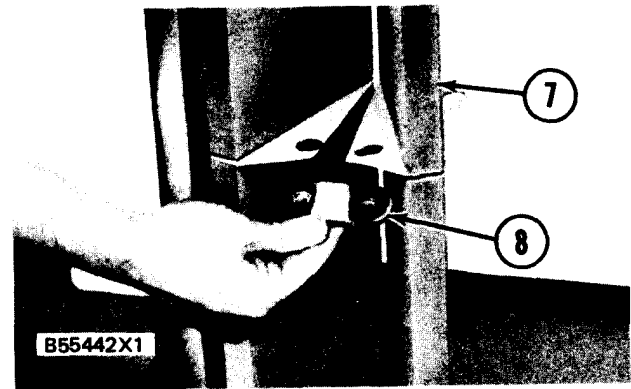

- Install the remainder of cores (7) in the bottom tank with the bevels together. Connect the cores with straps (8). Do not tighten the bolts. Make sure bracket (6) is installed on the other end core.

NOTE: Put the liquid soap on the seals just before assembly.

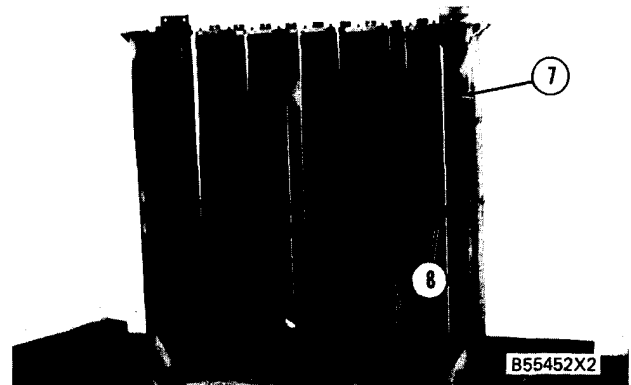

- Put liquid soap on the sealing areas of seals (9). Put liquid soap inside the holes of seals (9). Put seals (9) on the cores.

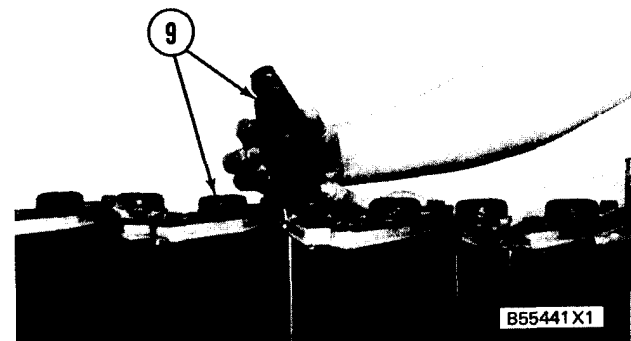

ENGINE

10. Make sure each hole in top tank (10) is clean. Put liquid soap on the sealing areas of the top tank for the seals. Install top tank (10). Make sure each core is in alignment with the holes in the top tank. Carefully push top tank (10) into position on the cores. Install the bolts that hold the channels to the top tank.

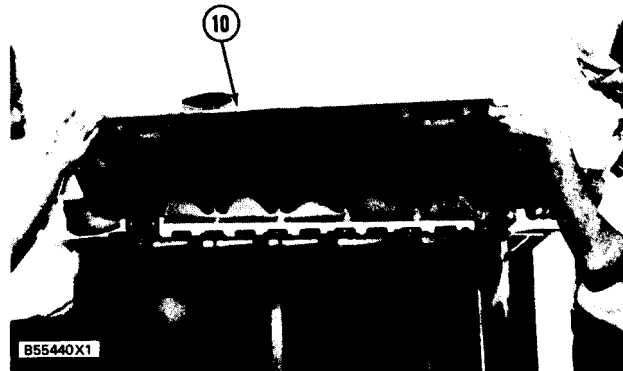

11. Make an adjustment to the cores to get a gap (X) of .25 in. (6.4 mm) between the bevel end of the cores (grille side).
12. Tighten straps (8) as the adjustments are made. Tighten the remainder of the bolts that hold the cores and top tank in place.



13. Install baffle assemblies (11) and (12).

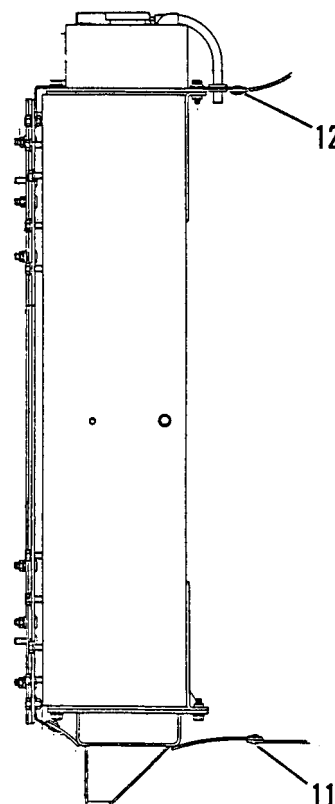

DISASSEMBLY AND ASSEMBLY

- 14. Secure shield assembly (13) to radiator with bolts (14).
- 15. Secure strip (15) to shield assembly with bolts (16).

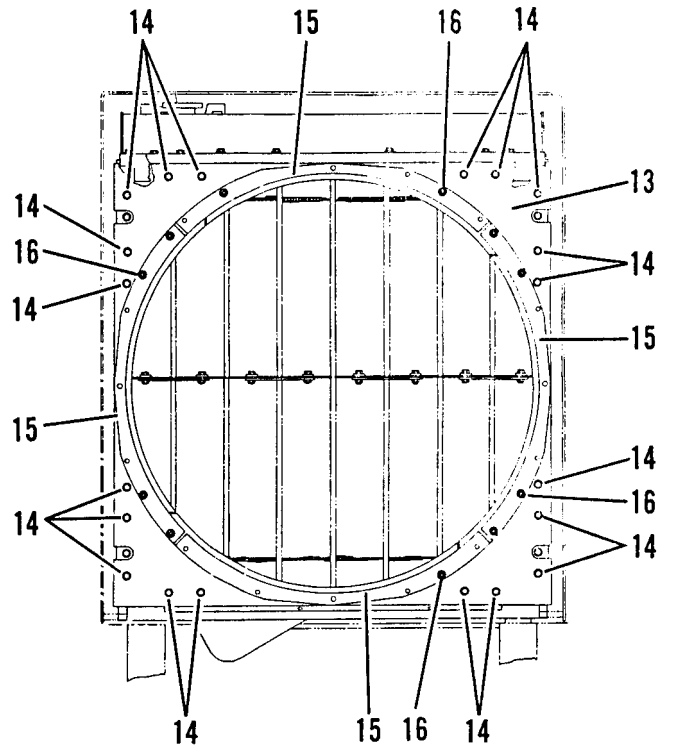

TURBOCHARGER

REMOVE TURBOCHARGER

start by:

a) remove muffler

1. Remove bolt (1), the nut and clips (2) from the tube assemblies.



2. Loosen nut (5) and remove bolts (3), the gasket and tube assembly (4) from the turbocharger and engine block.

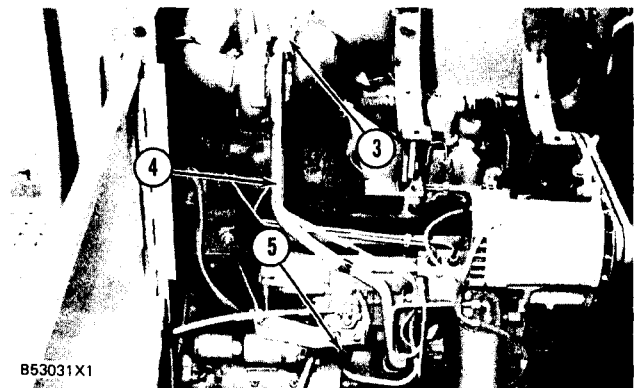

3. Remove bolts (6), the gasket and tube assembly (7) from the turbocharger and engine.

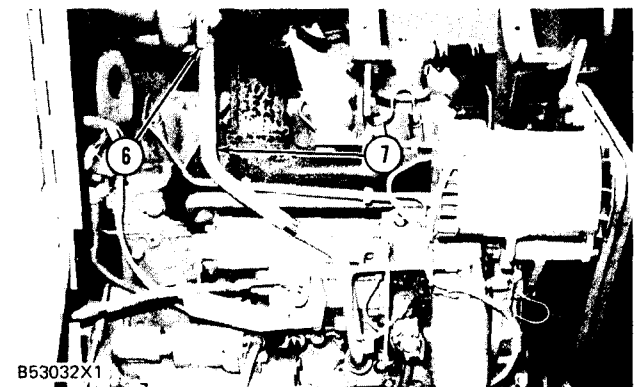

4. Loosen hose clamps (8) and (10).

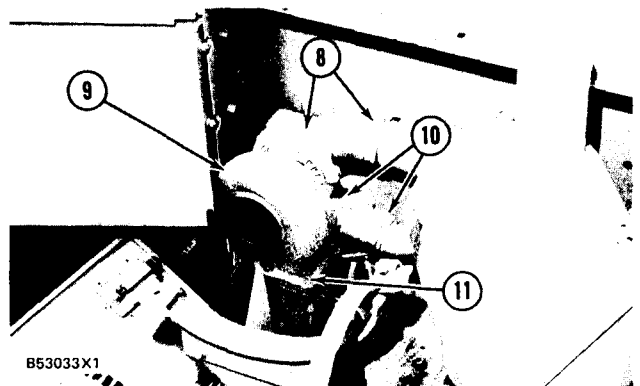

5. Remove bolts (11), the nuts, turbocharger (9) and the gasket from the engine.

TURBOCHARGER

INSTALL TURBOCHARGER

1052-12

1. Put gasket (2) and turbocharger (1) in position as shown. Install the bolts and nuts that hold the turbocharger to the exhaust manifold. Put 5P3931 Anti-Seize Compound on the threads of the bolts.



2. Make sure the O-ring seal is in position on the bottom of tube assembly (3) and install it in the engine.

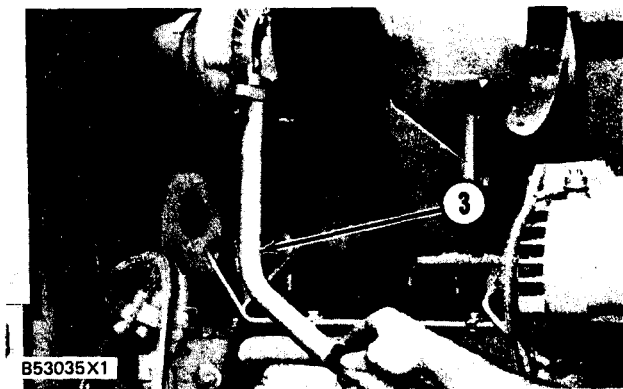

3. Put the gasket in position and connect tube assembly (3) to the turbocharger.

4. Install tube assembly (4) on the engine.

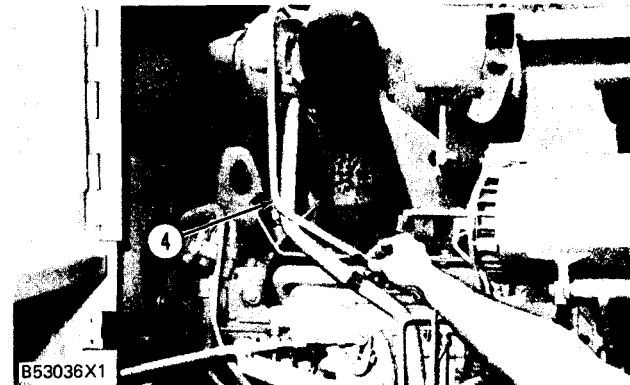

5. Put the gasket in position and connect tube assembly (4) to the turbocharger.

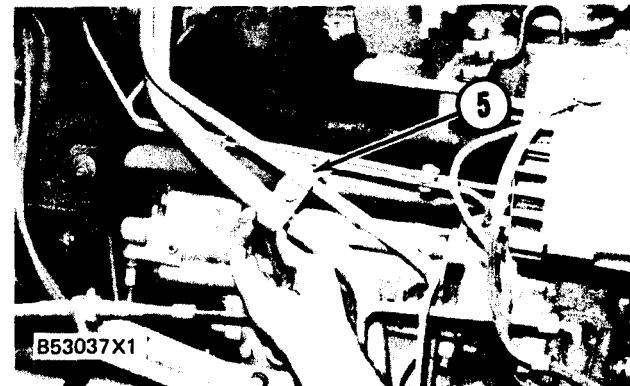

6. Install clips (5) that hold the tube assemblies together.
end by:
a) install muffler

TURBOCHARGER

DISASSEMBLE TURBOCHARGER 1052-15

Tools Needed		A	B	C
9S6363	Turbocharger Fixture Group 1			
9S6343	Fixture Assembly		1	
5S9566	T-Wrench			1

start by:

a) remove turbocharger

1. Put the turbocharger in position tool (A).
 2. Put a mark on compressor housing (1) and the backplate assembly for use at assembly. Remove the compressor housing from the backplate assembly.
 3. Change the position of tool (A) so the compressor wheel is up as shown.
 4. Put a mark on housing (2) and turbine housing (3) so that the housing can be put back in the same position in the turbine housing at assembly.
 5. Remove the bolts, lockplates and clamps that hold the housing in the turbine housing and remove the housing.
 6. Put the housing in position on tool (B).
 7. Use tool (C) and a socket of the correct size to remove nut (5) from the shaft.
- CAUTION**
Do not put a side force on the shaft when the nut is removed.
8. Remove compressor wheel (4) from the shaft.
 9. Remove the housing from the shaft.
 10. Remove shroud (6) from the turbine wheel and shaft.

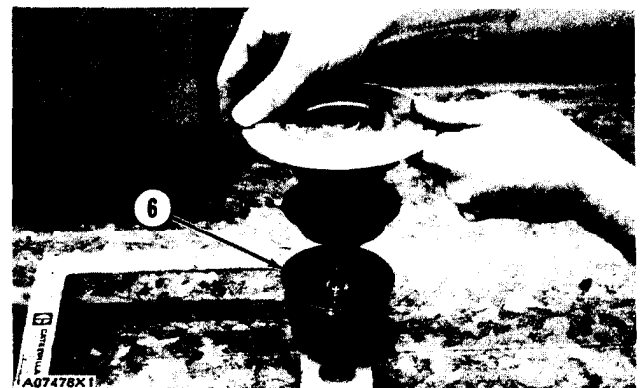
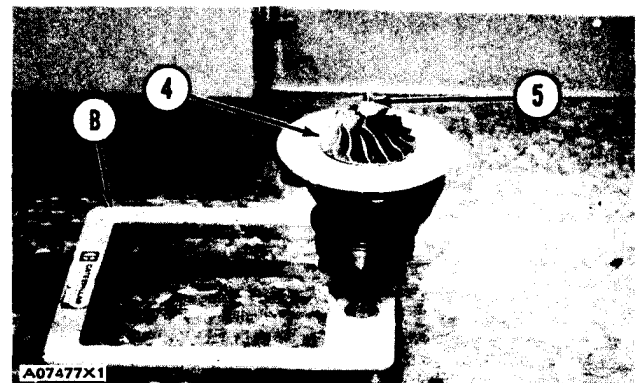
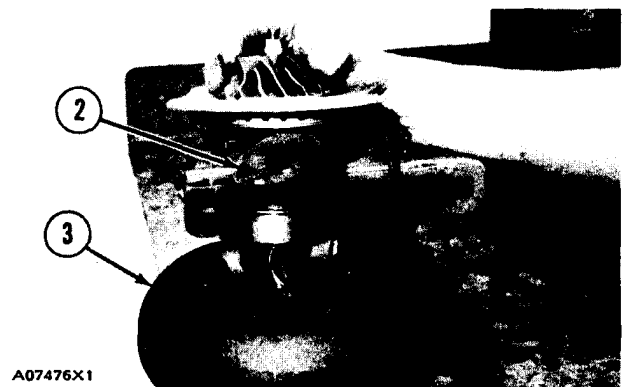

TURBOCHARGER

11. Remove seal ring (7) from the turbine wheel.

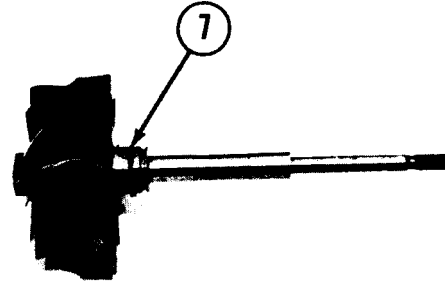

A07479X1

12. Put a mark on the housing and backplate assembly for use at assembly. Remove the bolts and plates that hold the housing to the backplate assembly. Remove the housing.

13. Remove bearing (8), collar (9) and the seal ring from backplate assembly (10).

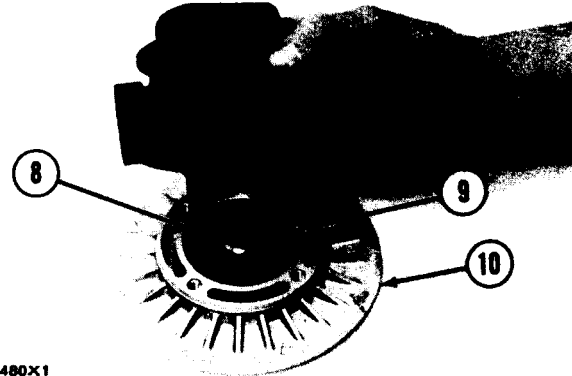

A07480X1

14. Remove the seal ring and bearing from the collar.

15. Remove seal ring (11) from the housing.

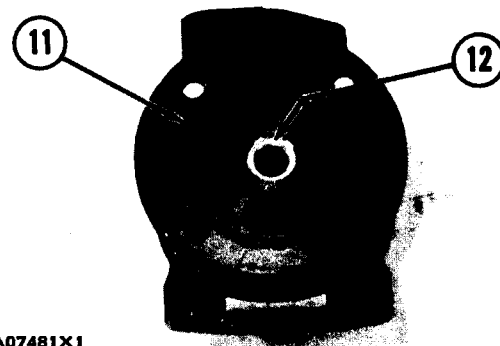

A07481X1

16. Remove the snap ring, bearing (12) and the snap ring from each side of the housing.

ASSEMBLE TURBOCHARGER 1052-16

	Tools Needed	A	B	C	D
9S6343	Fixture Assembly	1			
9S6363	Turbocharger Fixture Group		1		
9S9143	Gauge Group			1	
5S9566	T-Wrench				1

1. Make sure all oil passages are clean and free of all dirt or foreign material. Put clean engine oil on all of the parts before assembly.
2. Install the inner snap ring, bearing (1) and snap ring (2) in each side of the housing.

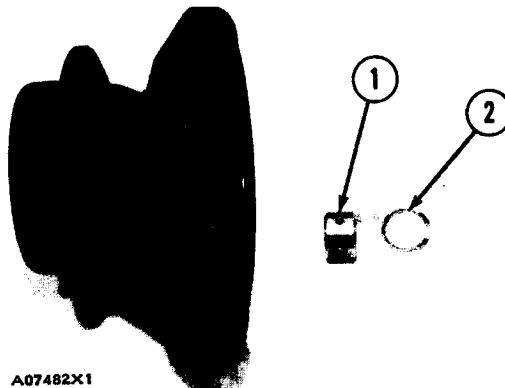

A07482X1

NOTE: The snap rings must be installed with the round side toward the bearing.

TURBOCHARGER

3. Install the seal ring on collar (4).

4. Put bearing (3) in position on the collar.

CAUTION

The oil grooves in the bearing must be clean and free of all dirt or foreign material. The bearing must be installed with the oil grooves toward the housing.

5. Put the bearing and collar in position on the housing so the oil grooves in the bearing are toward the housing and the holes in the bearing are in alignment with the pins in the housing.

CAUTION

Be extra careful during installation of the bearing and collar not to cause damage to the seal ring on the collar.

6. Install the seal ring on the housing.

7. Put the backplate assembly in position on the housing respective to the marks put on the housing and backplate at disassembly. Install the plates and bolts. Tighten the bolts to a torque of 8.5 - 10.2 N·m (75 - 90 lb.in.).

8. Install shroud (5) on the housing.

9. Put 6V2055 High Vacuum Grease in the groove for seal ring (7). Make sure the grease fills the groove approximately one half or more of the groove depth for the complete circumference of the groove to help make a carbon dam under the seal. Install seal ring (7). Carefully install turbine wheel and shaft (6) in the hous-

10. Put the housing, turbine wheel and shaft and the backplate assembly in position on tool (A).

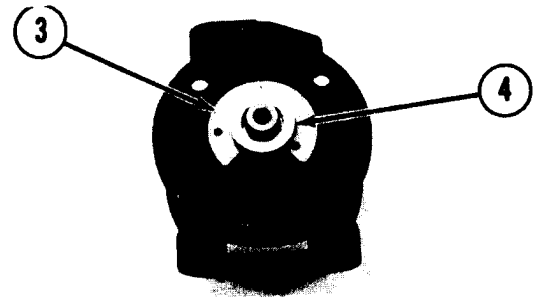

A07483X1

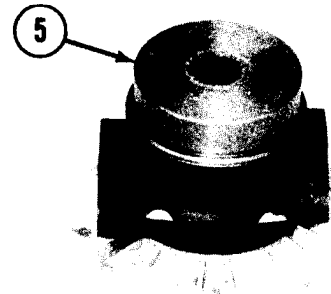

A07484X1

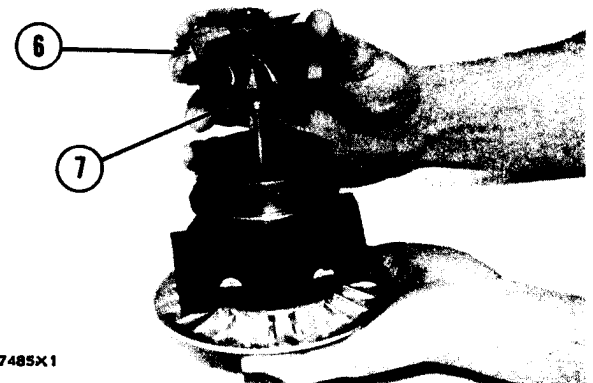

A07485X1

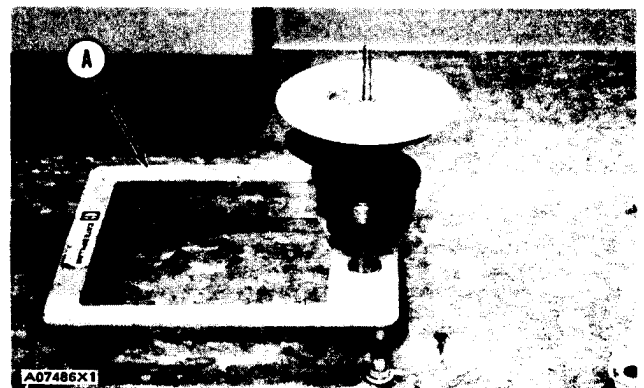

A07486X1

TURBOCHARGER

11. Install compressor wheel (8) on the turbine shaft.
12. Put clean engine oil on the threads of the shaft. Install the nut that holds the compressor wheel in place. Tighten the nut with tool (D) to a torque of 2.3 N·m (20 lb.in.). Put a mark on the nut and shaft. Tighten the nut 100° more.

CAUTION

When the nut is tightened, do not put a side force on the shaft.

13. If the turbine housing was removed from tool (B), put the turbine housing in position on tool (B).
14. Put the housing and wheels in position in the turbine housing respective to the marks put on the housings at disassembly.
15. Put 5P3931 Anti-Seize Compound on the threads of bolts (9). Install the clamps, lockplates and the bolts (9). Tighten the bolts to a torque of 13 ± 1.7 N·m (115 ± 15 lb.in.). Bend the lockplates against the bolt heads.

16. Put compressor housing (10) in position on the backplate assembly respective to the marks put on the housing and backplate assembly at disassembly.
17. Install the clamps, lockplates and bolts that hold the compressor housing in place. Tighten the bolts to a torque of 13 ± 1.7 N·m (115 ± 15 lb.in.). Bend the lockplates against the bolt heads.
18. Remove the turbocharger from tool (B).

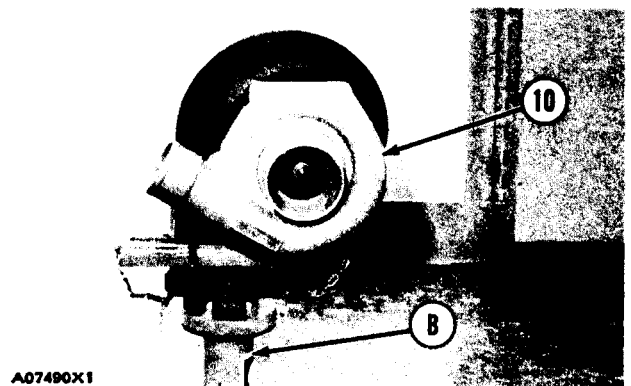
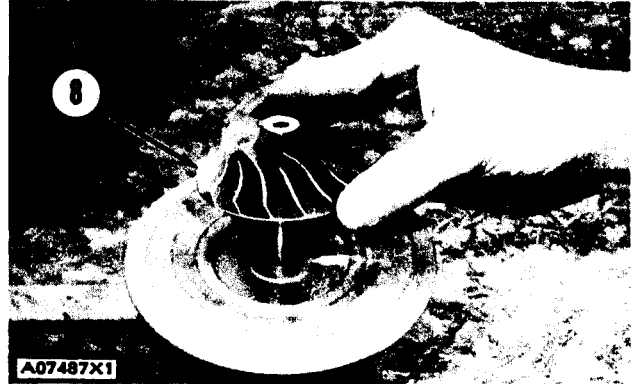

ENGINE

OIL FILTER BASE

REMOVE OIL FILTER BASE

1306-11

Tools Needed		A
2P8250	Strap Wrench	1

1. Open the rear right side access panel looking from the operator's seat.

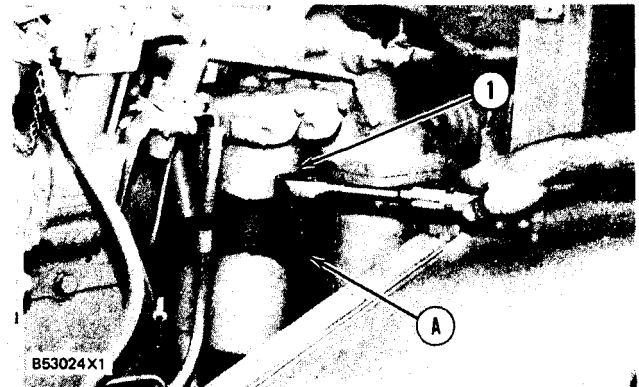

2. Use tool (A) and remove oil filter (1).

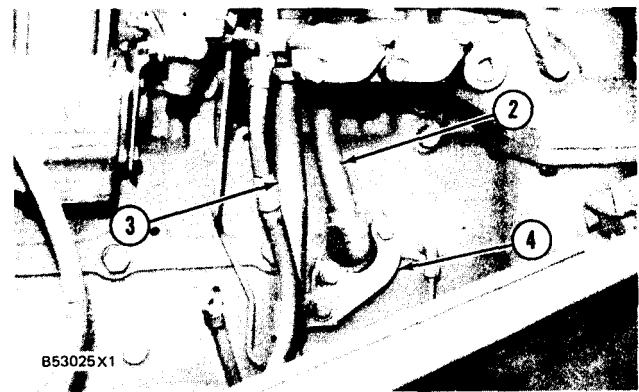

3. Remove the bolts, bracket (4) and tube assemblies (2) and (3) from the oil filter base and engine block.

4. Remove bolts (6) and oil filter base (5) from the oil cooler.

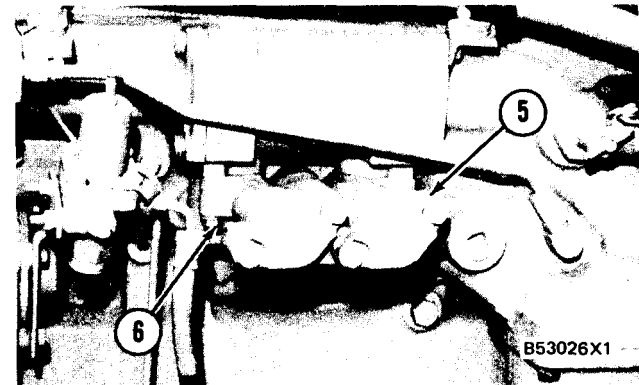

INSTALL OIL FILTER BASE

1306-12

1. Put clean oil on O-ring seals (1) and install them on oil filter base as shown.

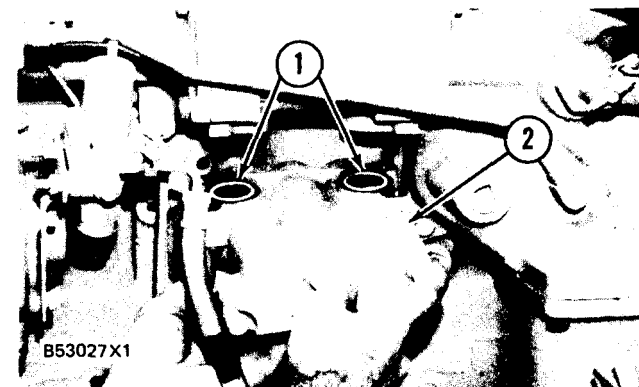

2. Install oil filter base (2) on the oil cooler.

OIL FILTER BASE

3. Install O-ring seals (3) on tube assemblies (4) and (5) and put clean oil on them.
4. Install tube assemblies (4) and (5) on the oil cooler and engine block.
5. Install bracket (6) on tube assemblies (4) as shown.
6. Put clean oil on the filter seal and install oil filter (7) on the oil filter base. Tighten the oil filter 1/2 turn after the seal makes contact with the filter base.
7. Close the access panel.

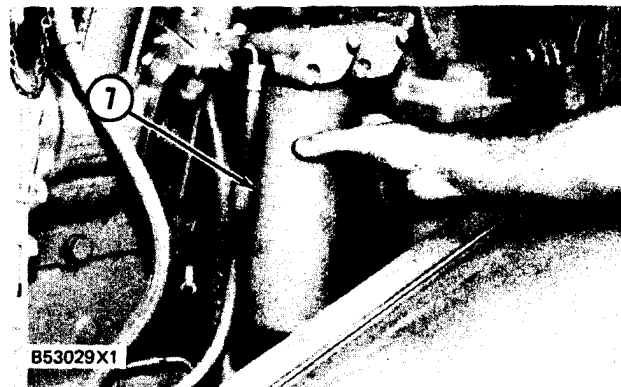
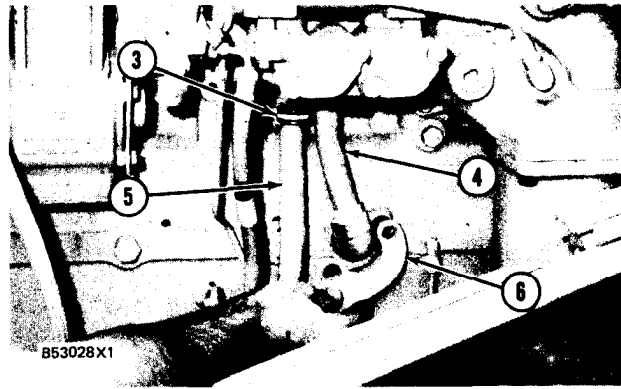

DISASSEMBLE OIL FILTER BASE 1306-15

start by:

- a) remove oil filter base

1. Remove three bolts (1) and covers (2) for the bypass valve.
2. Remove the springs and plungers from the base.

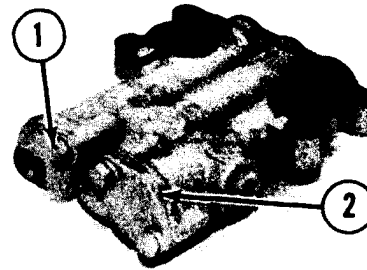

ASSEMBLE OIL FILTER BASE 1306-16

1. Install plunger (4), spring (3), cover (2) and bolts (1) for the cooler bypass valve in the oil filter base.
 2. Install plunger (7), spring (6), cover (5) and the bolts for the oil filter bypass valve in the oil filter base.
- end by:
- a) install oil filter base

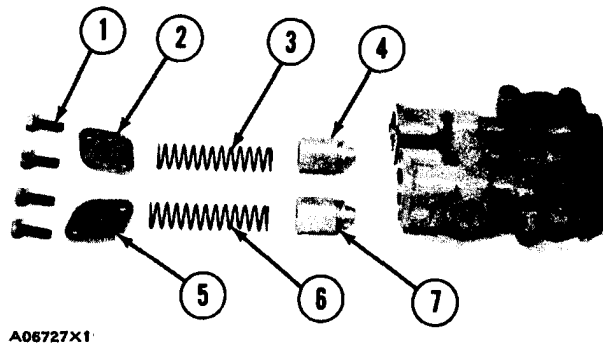

ENGINE

ENGINE OIL COOLER**REMOVE ENGINE OIL COOLER 1378-11**

start by:

a) remove oil filter base

1. Drain the coolant from the engine.
2. Remove bolt (4) that holds pipe (2) to the block.
3. Loosen clamps (1).
4. Remove bolts (3) and remove pipe (2) toward the front of the engine.
5. Remove four bolts (6), oil cooler (5) and the gaskets from the engine.

NOTE: The bottom rear bolt is a 3/8" twelve point head bolt.

6. Use a 3.175 mm (.125 in.) diameter rod (7) to clean each tube of the oil cooler.

INSTALL ENGINE OIL COOLER 1378-12

1. Make sure all gasket surfaces are clean and free of dirt.
 2. Put the gasket and oil cooler (2) in position on the bonnet and install the bolts.
 3. Move pipe (1) to connect it with oil cooler (2) and install the gasket and the bolts.
 4. Install the bolt that holds pipe (1) to the engine.
 5. Tighten hose clamps (3).
- end by:
- a) install oil filter base

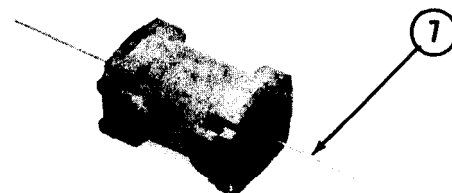
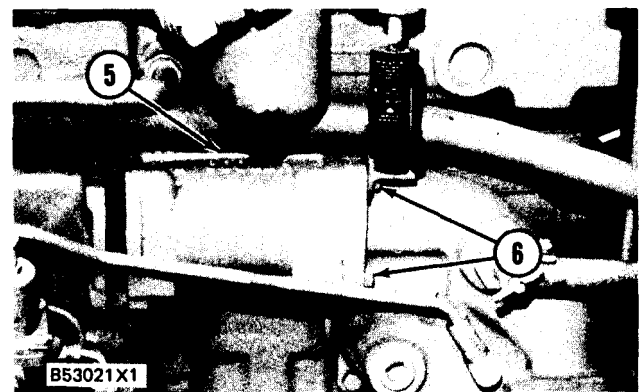
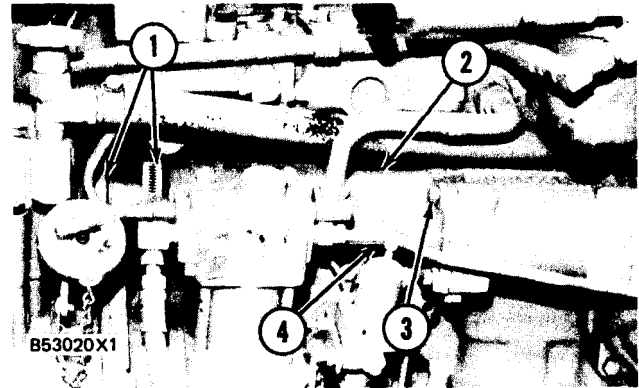

B53022X1

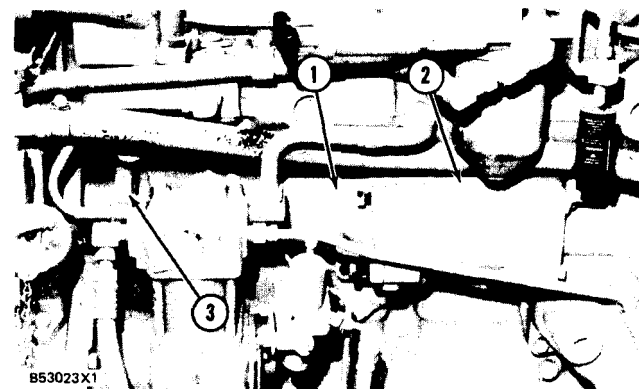

CRANKSHAFT PULLEY

REMOVE CRANKSHAFT PULLEY 1205-11

Tools Needed		A
8B7559	Adapter	2
8B7561	Step Plate	1
8B7550	Leg	2
8H684	Ratchet Box Wrench	1
8B7548	Puller Assembly	1

start by:

- a) remove radiator and guard
- b) remove fan

1. Loosen the nuts and bolts from the air conditioner compressor and remove vee belt (1) (if so equipped).
2. Loosen the bolt in the end of crankshaft pulley (2) until there is approximately 9.5 mm (3/8") between the retainer and crankshaft pulley. Install tooling (A) and loosen crankshaft pulley (2) from the crankshaft.
3. Remove tooling (A), the bolt, washer and crankshaft pulley (2) from the crankshaft.

INSTALL CRANKSHAFT PULLEY 1205-12

Tools Needed		A
Borrighs Tool Company Part No. BT-33-95		1

1. Put crankshaft pulley (1) in position on the crankshaft.
2. Install washer (2) so the maximum flat area is next to the crankshaft pulley and bolt (3) as shown.
3. Install two 1/2"-13 NC bolts 2 in. long in the pulley. Put a pry bar between the bolts and against the frame so the crankshaft will not turn while bolt (2) is tightened to the correct torque.
4. Tighten bolt (2) to a torque of 312 ± 27 N·m (230 ± 20 lb. ft.). Hit the bolt with a hammer. Tighten the bolt again to a torque of 312 ± 27 N·m (231 ± 20 lb.ft.).
5. Install vee belt (4) on the air conditioner compressor and the crankshaft pulley (if so equipped).
6. Use tool (A) to measure the belt tension. Adjust the belt tension until the gauge reading for a new belt is 534 ± 22 N (120 ± 5 lb.). Adjust the belt tension until the gauge reading for a used belt is 400 ± 44 N (90 ± 10 lb.). A used belt is one which has more than 30 minutes of operation at rated engine speed. When the belt tension is correct, tighten all the bolts and nuts in the mounting bracket.

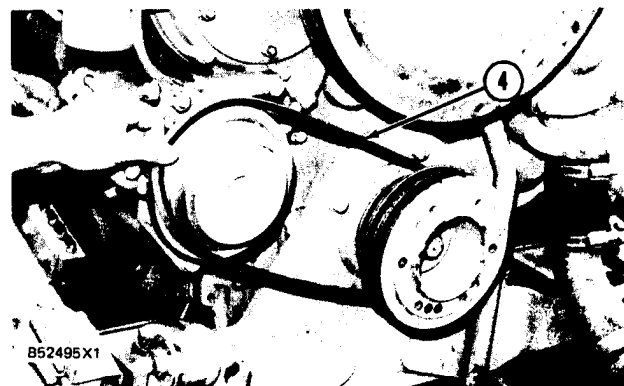
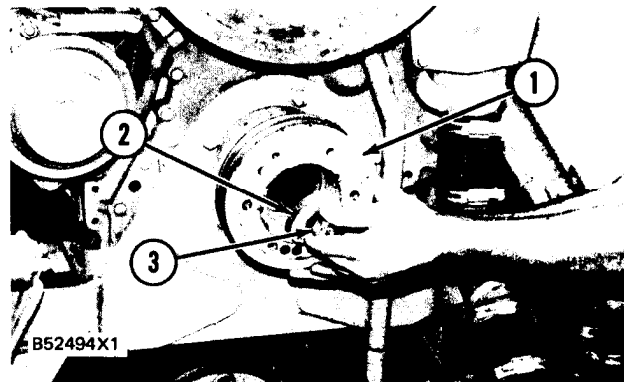
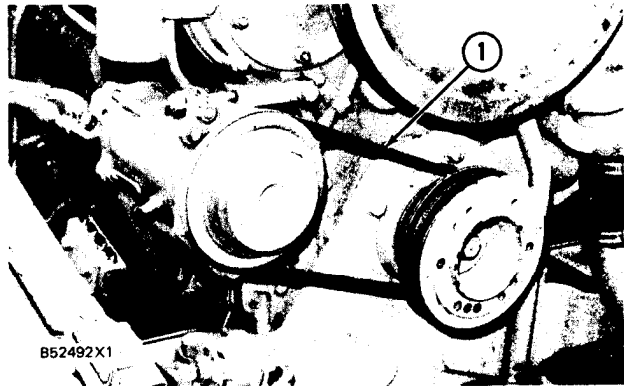

CRANKSHAFT FRONT SEAL AND WEAR SLEEVE**REMOVE CRANKSHAFT FRONT SEAL
AND WEAR SLEEVE**

1160-11

Tools Needed		A	B	C
1P3075	Puller Assembly	1		
5P7312	Distorter		1	
5P7315	Ring			1

start by:

a) remove crankshaft pulley

NOTE: When a replacement of the front seal is made, a replacement of the wear sleeve is to be made also.

1. Remove the crankshaft front seal with tooling (A).
2. Install tool (C) into the seal bore.
3. Install tool (B) between tool (C) and the wear sleeve. Turn tool (B) until the edge of the tool makes a flat place (crease) in the wear sleeve. Do this in two or more places until the wear sleeve is loose.
4. Remove tool (C) and the wear sleeve by hand.

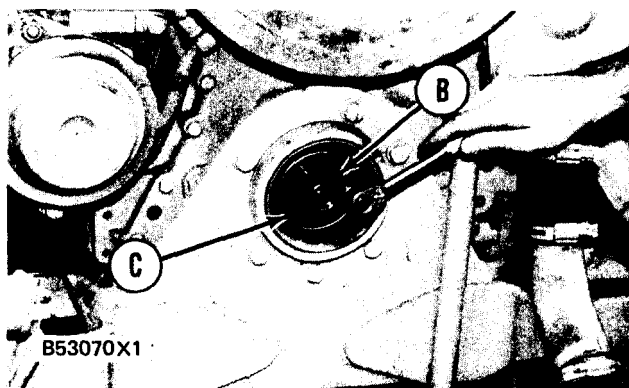
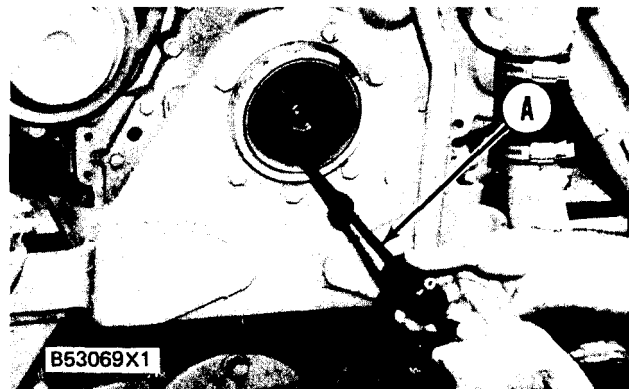
**INSTALL CRANKSHAFT FRONT SEAL
AND WEAR SLEEVE**

1160-12

Tools Needed		A
5P7299	Installer	1
7F8022	Bolt	1

NOTE: The wear sleeve and seal must be installed together.

1. Put clean engine oil on the seal lip and on the outside diameter of wear sleeve (1). Install the seal on the wear sleeve as shown with the lip of the seal toward the side of the wear sleeve that has the chamfer on the inside diameter.
2. Use 6V1541 Quick Cure Primer to remove any oil from inside diameter "X" of the wear sleeve and surface "Y" of the crankshaft. Make an application of 9S3265 Retaining Compound to surfaces "X" and "Y".
3. Put the wear sleeve and seal on to the crankshaft as shown with the lip of the seal toward the engine.
4. Install tooling (A) as shown and put lubricant between the bolt head and installer.
5. Use tooling (A) to push the wear sleeve and seal on to the crankshaft until the installer is against the end of the crankshaft. The wear sleeve and seal will then be in the correct location.
6. Remove tooling (A).

end by:

a) install crankshaft pulley

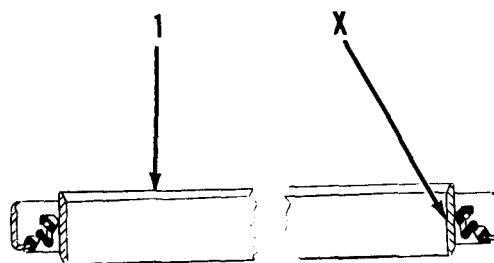

A44158X1

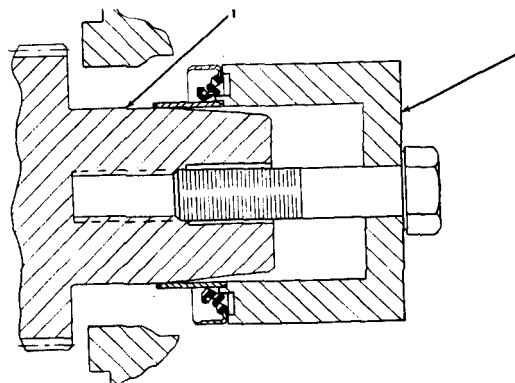

A44172X1

OIL PAN

REMOVE OIL PAN

1302-11

Tools Needed		A	B
	OTC Model 1790 Transmission Jack	1	
8S7630	Stand		2
8S7615	Pin		2
8S7621	Tube		2

1. Put tool (A) in position under guard (1) as shown. Remove the bolts and guard (1) from the machine. The weight of the guard is approximately 32 kg (70 lb.).
2. Drain the oil from the engine.
3. Remove the bolt and disconnect the clip that holds breather tube (2) to the engine.
4. Loosen clamps (3) and remove breather tube (2) from the engine.
5. Loosen nuts (7) and (4) and remove tubes (5) and (6) from the engine.
6. Remove eight nuts (8) and the bolts that hold the rear axle housing and support (10) to the machine.
7. Install eight 12" long guide bolts (9) to keep rear axle housing and support in alignment.
8. Lift the rear of the machine approximately 101.6 mm (4 in.) so there is enough clearance to remove the oil pan. Install tooling (B).

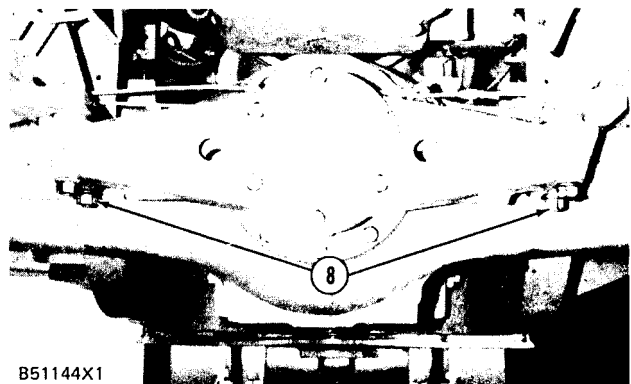
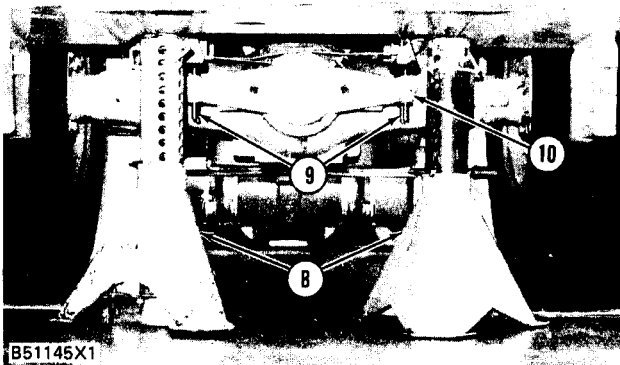
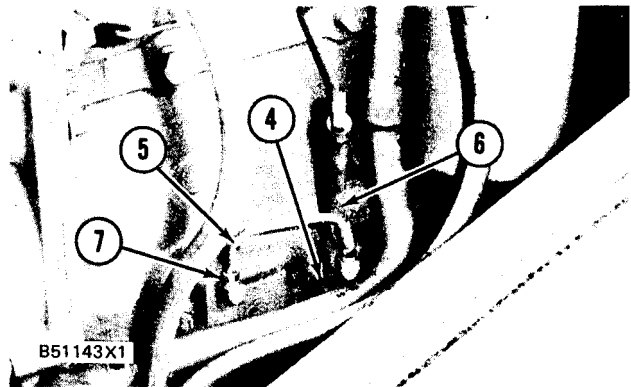
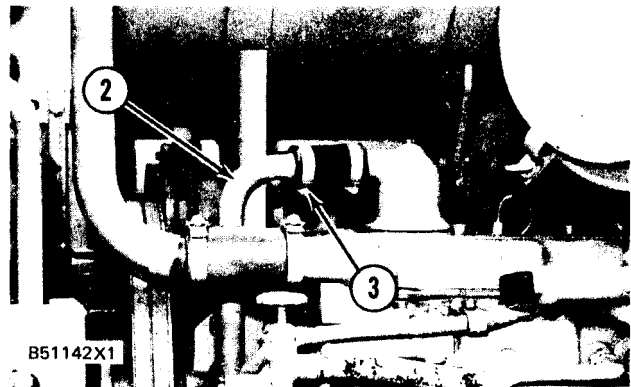
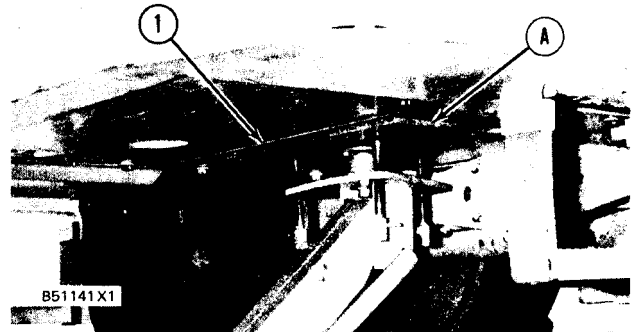

ENGINE

OIL PAN

9. Remove oil cooler bracket (11) from the oil pan and the cooler.
10. Remove the bolt, nut and breather tube bracket (12) from the oil pan.
11. Remove bolts (13) and oil pan (14) from the engine.

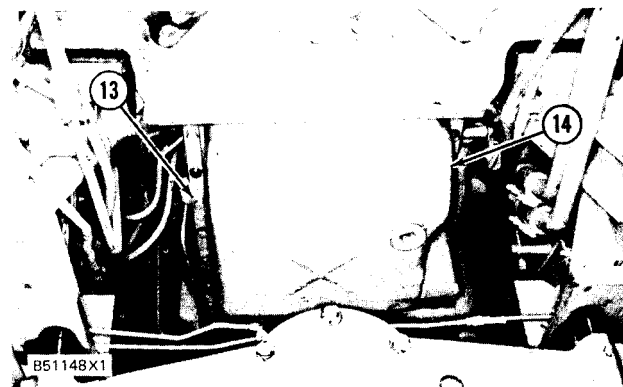
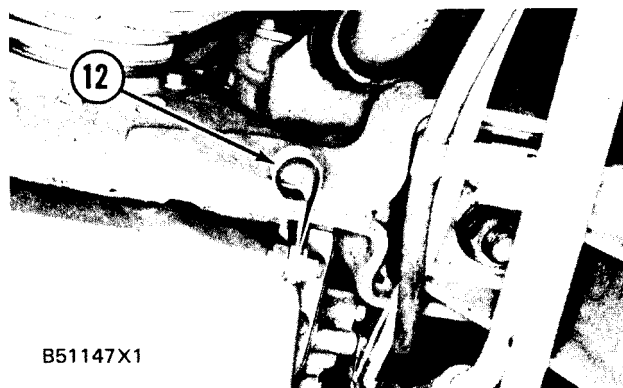
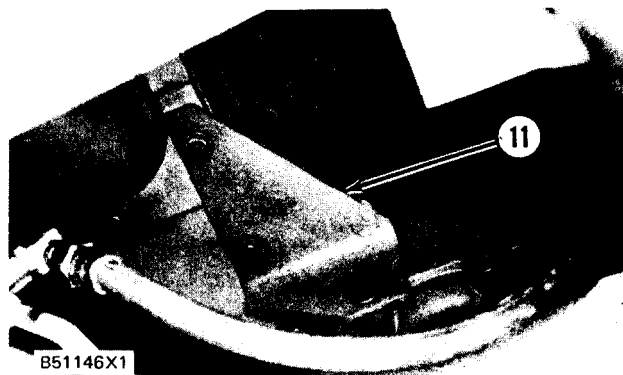

INSTALL OIL PAN

1302-12

Tools Needed		A	B
8S7630	Stand	2	
8S7615	Pin	2	
8S7621	Tube	2	
OTC Model 1790 Transmission Jack			1

1. Inspect the oil pan gasket and make a replacement if necessary.
2. Put oil pan (3) in position and install bolts (2) that hold it.
3. Install breather bracket (1) on the oil pan.
4. Install oil cooler bracket (4) to the oil pan and the cooler.

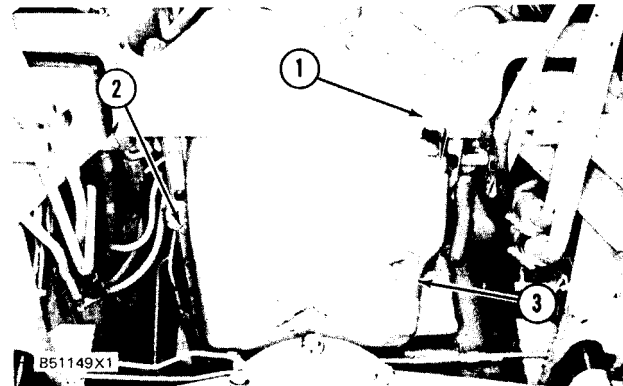
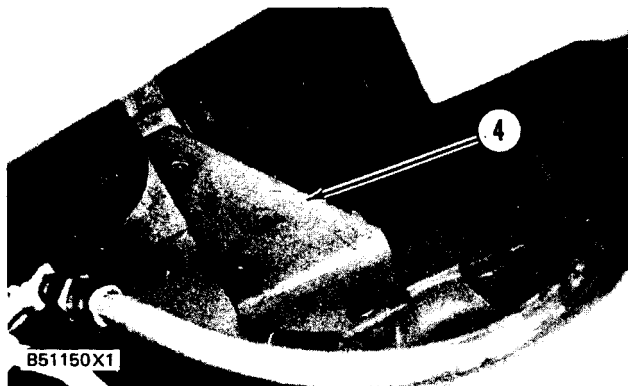

OIL PAN

5. Lift the rear of the machine and remove tool (A).

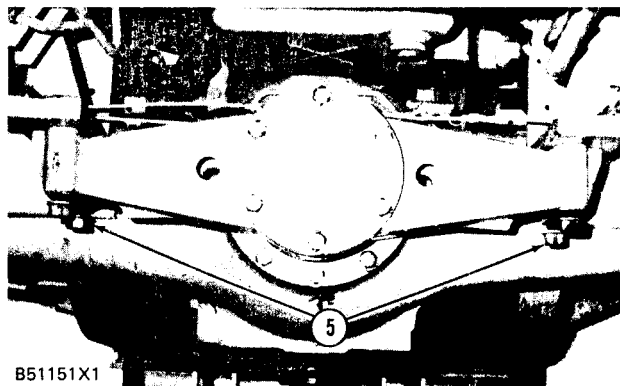

6. Remove the guide bolts and install the bolts and nuts (5) that hold the rear axle and support to the machine. Tighten the bolts to a torque of 475 ± 50 N·m (350 ± 37 lb. ft.).

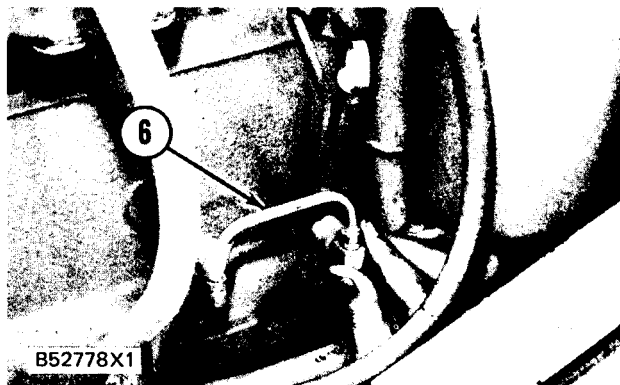

7. Install tube assemblies (6) on the engine as shown.

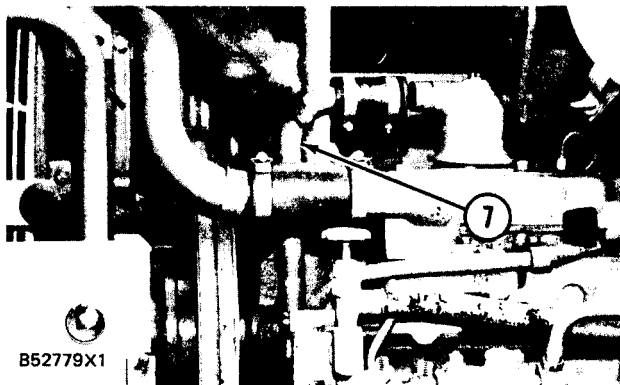

8. Install breather tube (7) on the breather as shown.

9. Use tool (B) to install guard (8) as shown.

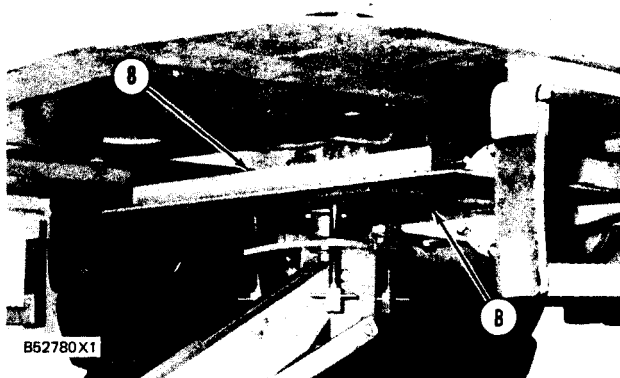

10. Fill the engine with clean oil to the correct level. See MAINTENANCE GUIDE.

OIL PAN PLATE

REMOVE OIL PAN PLATE

1302-11

start by:

- a) remove oil pan

NOTE: The suction bell has been removed for photo illustration only.

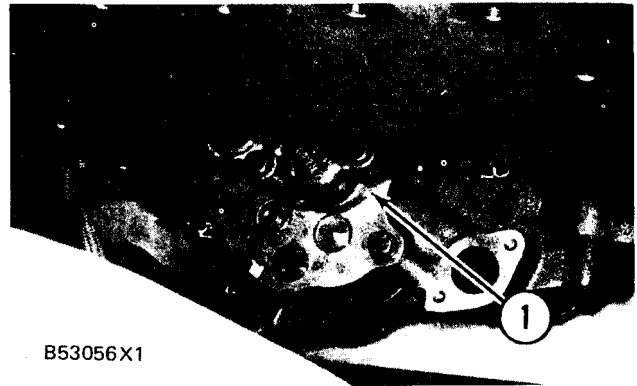

1. Remove the bolts that hold tube assembly (1) in place.

2. Remove bolts (2), oil pan plate (3) and the gasket from the engine.

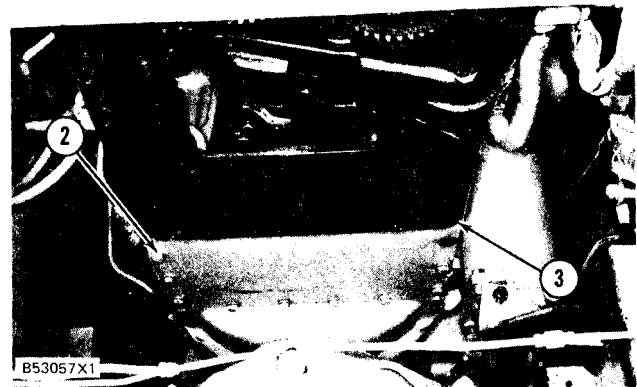

3. Remove the old gasket material from the plate and cylinder block.

INSTALL OIL PAN PLATE

1302-12

1. Put 5H2471 Gasket Cement on the flywheel and timing gear joints.

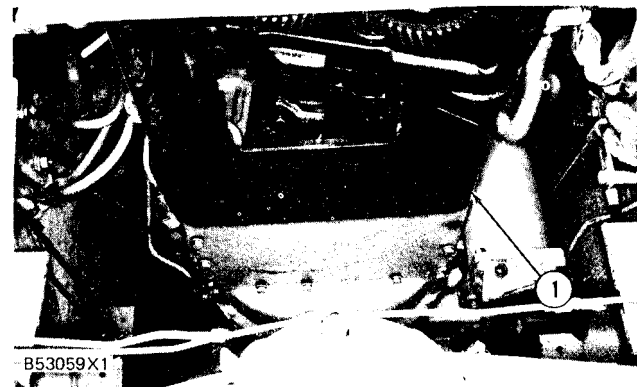

2. Install the gasket on oil pan plate (1).

3. Install oil pan plate (1) on the cylinder block.

4. Install bolts (2) that hold the tube assembly to the oil pump.

end by:

- a) install oil pan

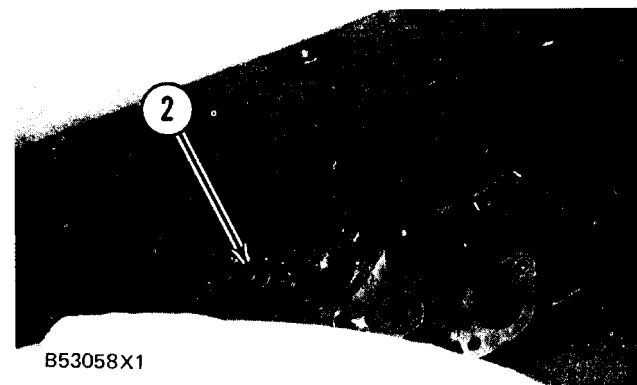

OIL PUMP

REMOVE OIL PUMP

1304-11

start by:

a) remove oil pan

1. Remove the bolts, the locks and suction bell (1) from the oil pump.
2. Remove bolts (2) and make a separation of the tube from oil pump (3).

CAUTION

The larger gear is not fastened to the pump.

3. Remove bolts (4), the locks and oil pump (3) from the engine block.

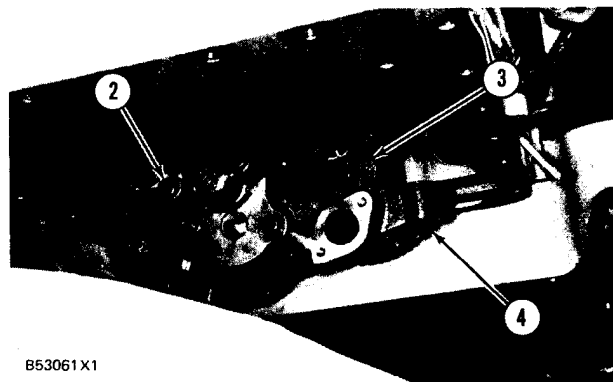
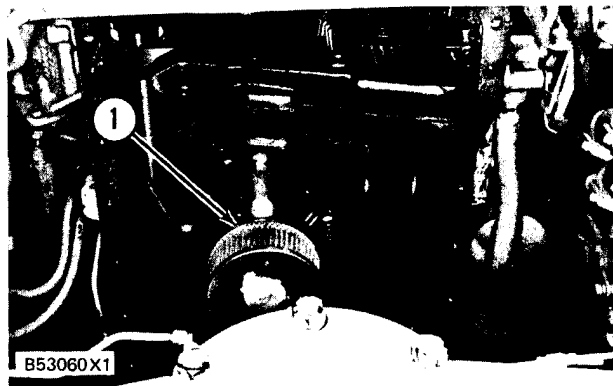

INSTALL OIL PUMP

1304-12

1. Turn the crankshaft until the No. 1 piston is at the top center compression position. See INSTALL FUEL INJECTION PUMP HOUSING AND GOVERNOR.
2. Turn both balancer shafts until the flat part on each shaft is away from the oil pan plate. Install two 3/8"-16 NC bolts (1) 1 1/2" long through the oil pan plate and into the holes in the balancer shafts. This will make the shafts so they will not turn. Do not tighten the bolts against the bottom of the holes in the shafts.
3. Put the oil pump (2) in position on the engine block and install the locks (left side only) and bolts that hold the oil pump in place.
4. Remove bolts (1). Check to see that the balancer shaft timing is correct. The balancer shaft timing is correct when the holes in the balancer shafts are in alignment with the holes in the oil pan plate, and No. 1 piston is at the top center compression position.
5. Connect tube assembly (4) to the oil pump.
6. Install suction bell (3) and the gasket to the oil pump.

end by:

a) install oil pan

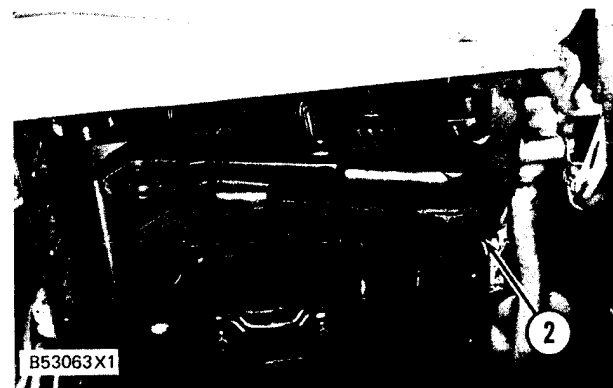
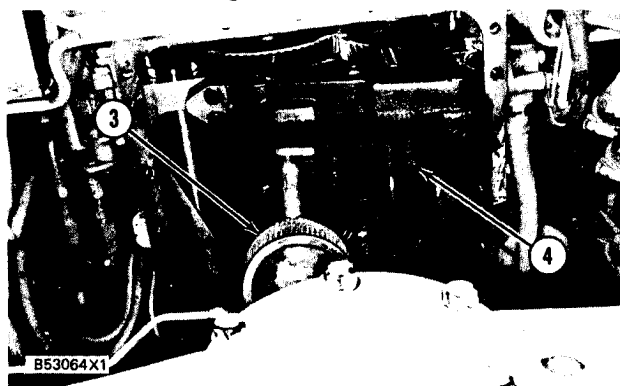
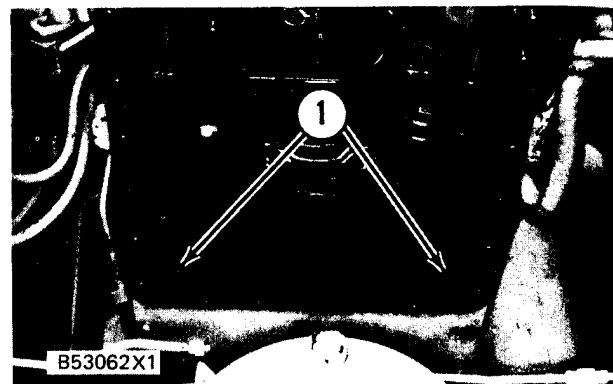

OIL PUMP

DISASSEMBLE OIL PUMP

1304-15

Tools Needed		A	B	C
1P2320	Puller Assembly	1		
867560	Step Plate	1		
1P529	Handle		1	1
1P466	Drive Plate		1	
1P465	Drive Plate		1	
1P462	Drive Plate			1
1P461	Drive Plate			1

start by:

a) remove oil pump

1. Remove idler gear (2).
2. Remove bearing (1) from gear (2) with tooling (B).
3. Remove the bolt and the washer from the oil pump drive gear.
4. Remove the drive gear from the shaft with tooling (A).
5. Remove the key from the pump shaft.
6. Remove bolts (3) from the pump body.
7. Remove body (8), two gears (7), keys and spacer (4) from the pump.
8. Remove two shafts (5) and the gears.
9. Remove bolts (6), the cover and the pressure relief valve from the body.
10. Remove the bearings from the oil pump body assembly and the scavenge pump body assembly with tooling (C).

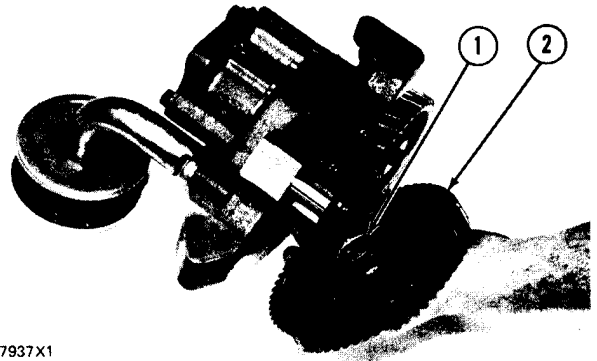

B37937X1

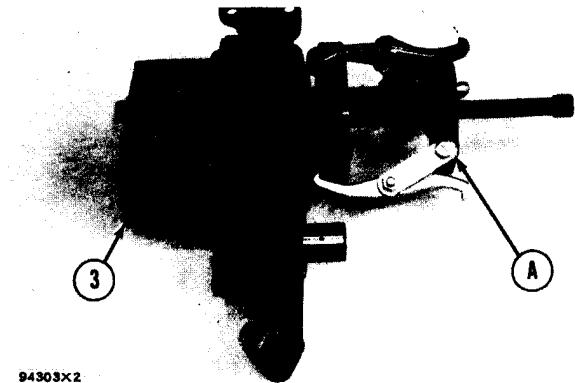

94303X2

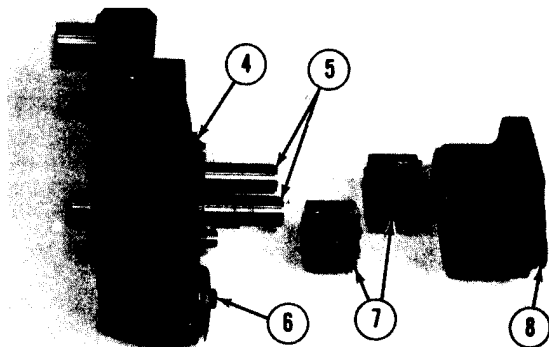

94307X2

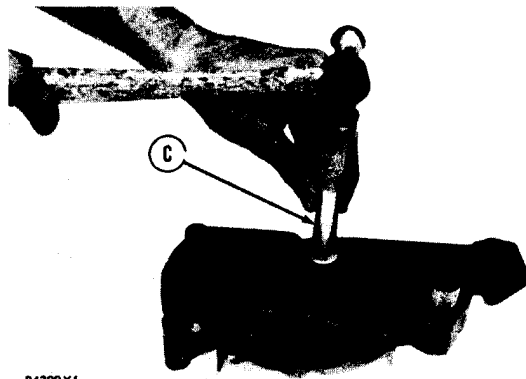

94299X1

OIL PUMP

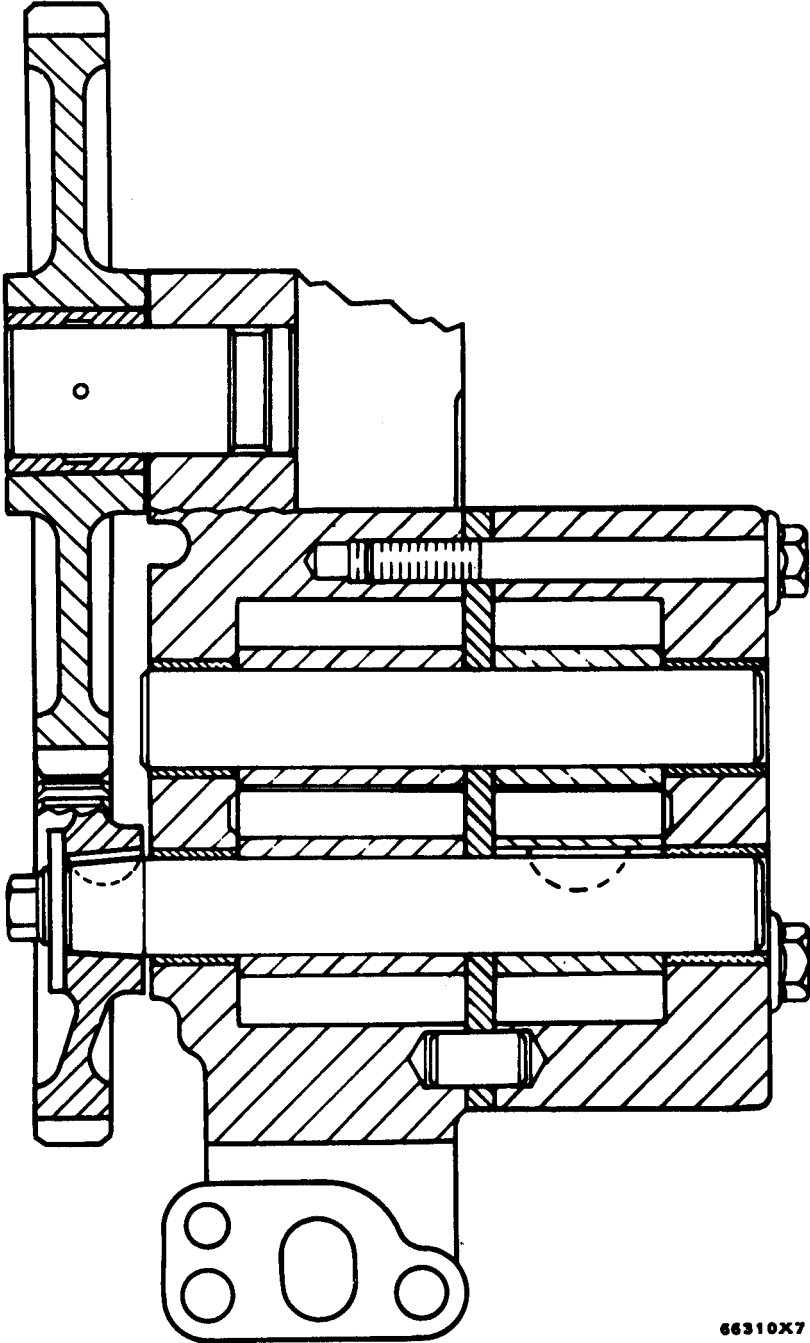

66310X7

OIL PUMP

ASSEMBLE OIL PUMP

1304-16

Tools Needed		A	B
1P529	Handle	1	1
1P461	Drive Plate	1	
1P462	Drive Plate	1	
1P465	Drive Plate		1
1P468	Drive Plate		1

1. Install the bearings in the scavenge pump body assembly with tooling (A) as follows:
 - a) Put bearings (1) in position on the inside of the scavenge pump body assembly with the chamfer on the bearing toward the outside of the pump body. Install the bearing until it is .060 in. (1.52 mm) below the inside machined surface of the scavenge pump body assembly. Make sure the joints in the bearings are at an angle of $30^\circ \pm 15^\circ$ from the center line through the bores in the scavenge pump body and toward the outlet passage of the pump. The outlet passage has a cavity between the bearing bores.

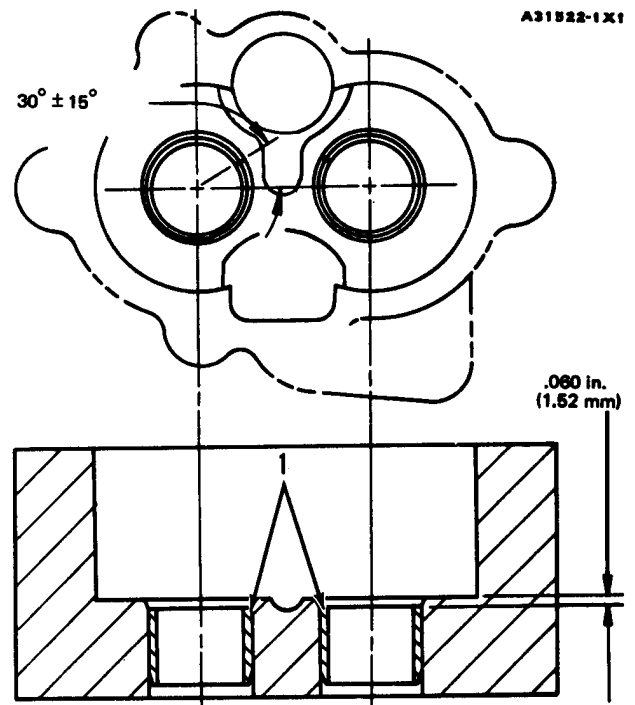

2. Install the bearings in oil pump body assembly with tooling (A) as follows:
 - a) Put bearings (2) in position on the inside of the oil pump body assembly with the chamfer on the bearings toward the outside of the pump body. Install the bearings until they are even with the outside of the pump body. Make sure the joints in the bearings are at an angle of $30^\circ \pm 15^\circ$ from the centerline through the bearing bores and toward the outlet passage of the pump. The outlet passage has a cavity between the bearing bores.

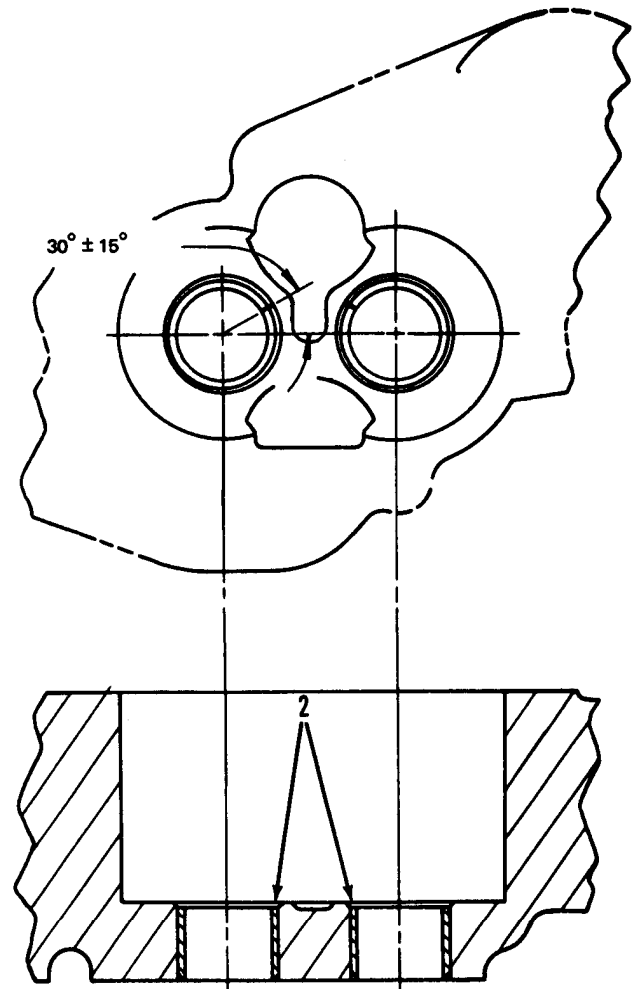

3. Check the condition of the relief valve. Check the condition and specifications for all the parts of the oil pump before it is assembled. See OIL PUMP (2P1785) in SPECIFICATIONS.

OIL PUMP

4. Put clean engine on all of the parts of the oil pump.

5. Install pressure relief valve (3), cover (4) and bolt (5) in the oil pump body assembly.

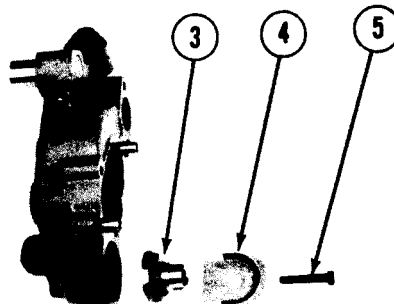

94308X3

6. Install gears and shafts (6) in the oil pump body assembly.

7. Install spacer (7) and the two keys in shafts (6).

8. Install two gears and scavenge pump body assembly (8).

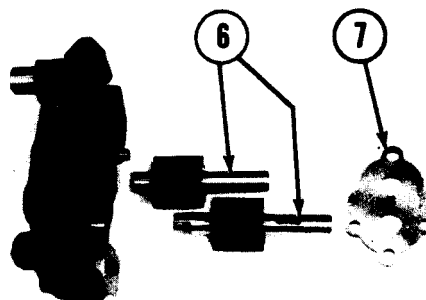

94302X3

9. Install key (9), drive gear (11), the washer and bolt (10). Tighten the bolt to a torque of 43 ± 7 N·m (32 ± 5 lb. ft.).

10. Install the bearing in the idler gear with tooling (B) until it is even with the outside surface of the gear.

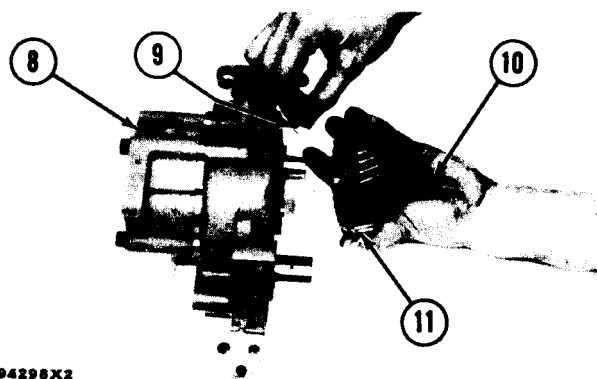

94298X2

11. Install the idler gear (13) and suction bell (12).

CAUTION

The oil pump must turn freely by hand after it is assembled.

end by:

- a) install oil pump

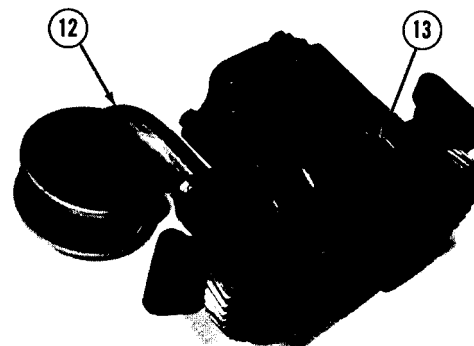

B37938X1

ENGINE FRONT SUPPORT**REMOVE ENGINE FRONT SUPPORT 1153-11**

Tools Needed		A
2B9886	Hydraulic Jack	2
FT1321	Support Beam	1

start by:

- a) remove crankshaft pulley
- b) remove oil pan

1. Remove the bolts and suction bell (1) from the engine.

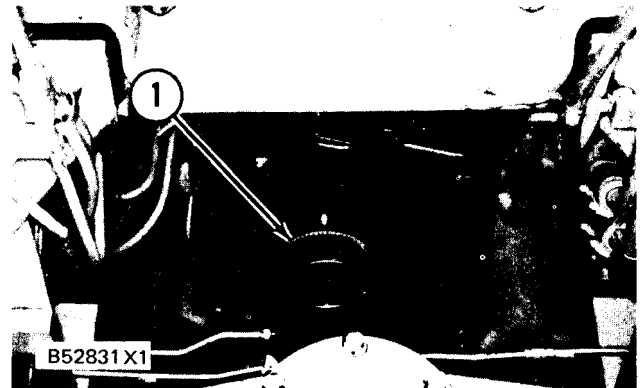

2. Put tooling (A) and wooden blocks in position under the engine as shown to support the front of the engine.

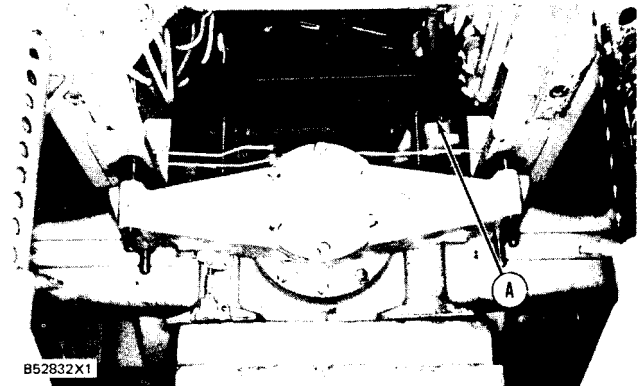

3. Loosen clamp (2) and remove elbow assembly (3) from the water pump.

4. Remove bolts (4) and mount assemblies (5) from the machine.

NOTE: Models 950BNS and 950BS is shown. Front support for 950BNSCE and 950BSCE is similar.

5. Use tooling (A) to lift the front of the engine to a maximum of 25.4 mm (1 in.) so there is no weight on front supper (7).

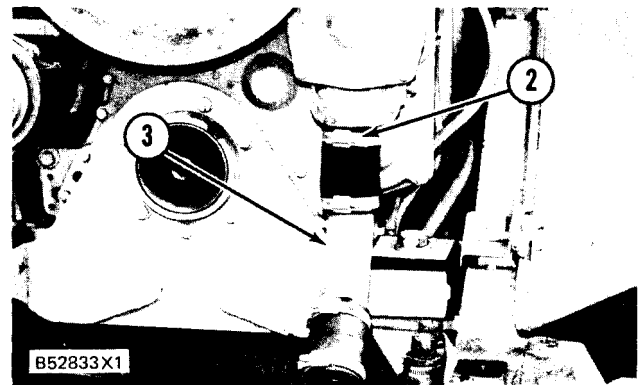

6. Remove bolts (6) and rent support (7) from the engine.

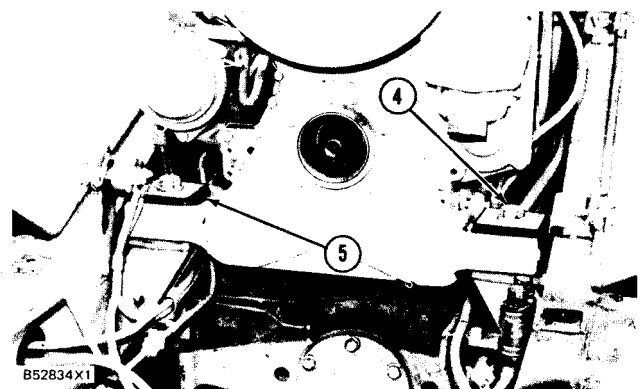
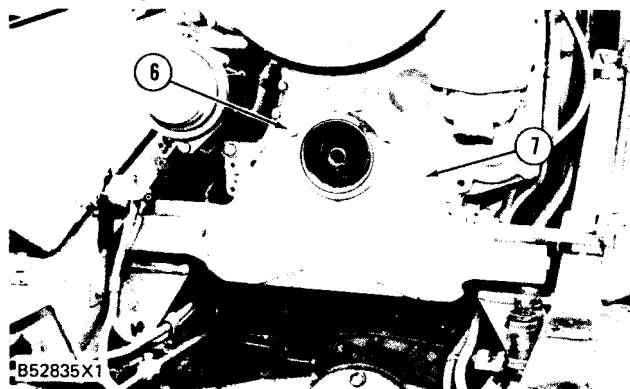

ENGINE FRONT SUPPORT

INSTALL ENGINE FRONT SUPPORT 1153-12

Tools Needed		A
2B9886	Hydraulic Jack	2
FT1321	Support Beam	1

1. Put front support (1) into position on the engine and install the bolts that hold it.

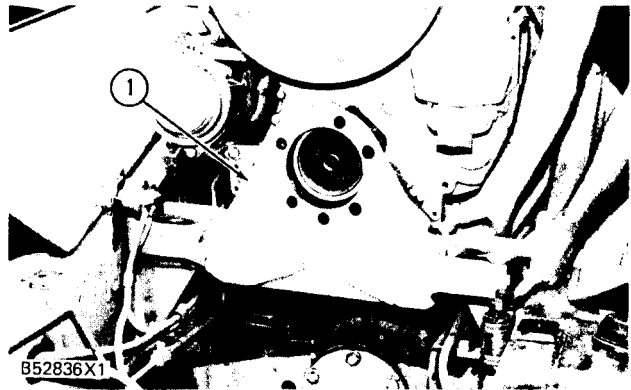

2. Lower tooling (A) so the weight of the front of the engine is on front support (1).

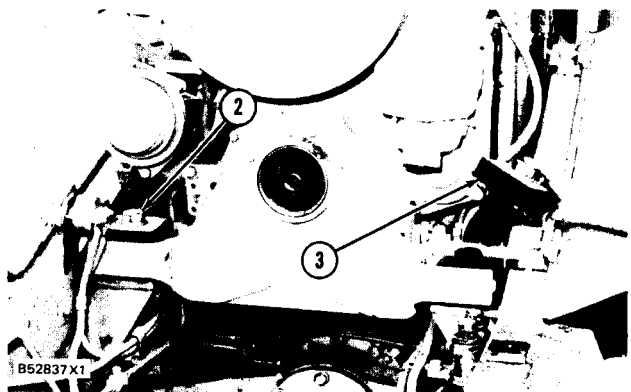

3. Install mount assemblies (3) and bolts (2) on bolt sides of the frame.

4. Install elbow assembly (4) on the water pump.

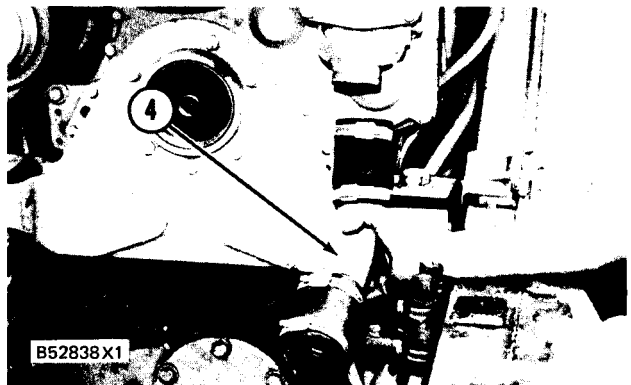

5. Remove tooling (A) from under the engine.

6. Install suction bell (5) on the engine.

end by:

- a) install crankshaft pulley
- b) install oil pan

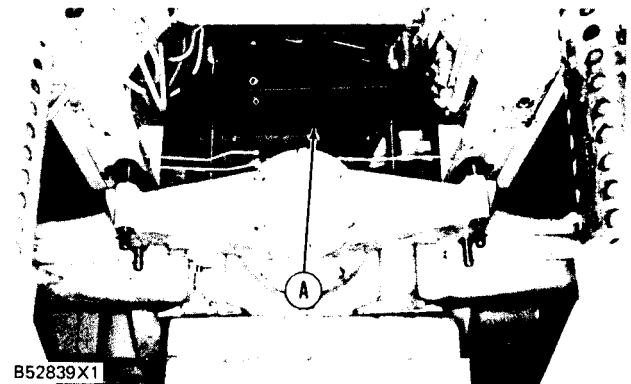
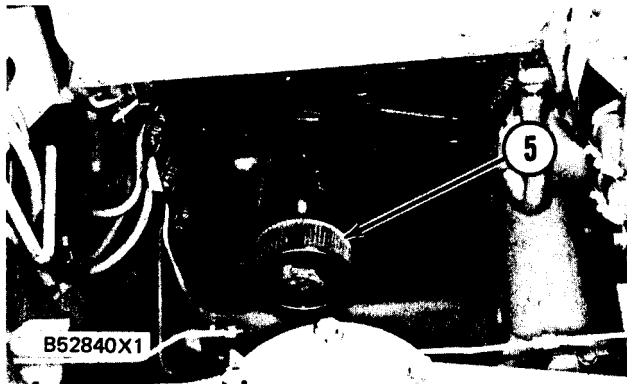

ENGINE

TIMING GEAR COVER

REMOVE TIMING GEAR COVER

1166-11

start by:

- a) remove air compressor
- b) remove alternator
- c) remove air conditioning compressor
- d) remove water pump
- e) remove fan drive
- f) remove engine front support

1. Remove the bolts and disconnect clips (4) and (5) from the engine.
2. Disconnect fuel line (2) from the fuel priming pump and move it away from the front cover.
3. Remove the bolt and disconnect ground wire from alternator bracket (3).
4. Remove the bolts and alternator bracket (3) from the front cover.
5. Remove the bolt and adjusting bracket (1) from the front cover.
6. Install spacers (8) to each side of engine between oil pan plate and the engine block as shown.

CAUTION

Use care when the trunnion is removed and installed to prevent damage to the crankshaft front seal.

7. Remove bolts (7), trunnion (6) and the O-ring seal from the front cover.
8. Remove bolts (9), cover (10) and the gasket from the timing gear plate.

NOTE: Put marks on all the bolts and their location on timing gear cover (11) before removal. For information about bolts at locations (X), see Page 5-72.

9. Remove bolts (11) and timing gear cover (12) from the engine.
10. Clean the old gasket from the contact surfaces of the timing gear cover and timing gear plate.

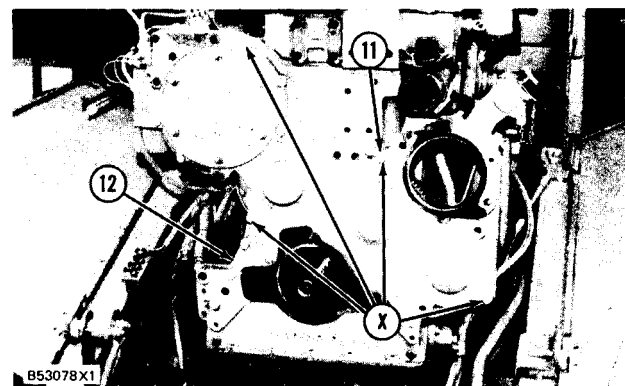
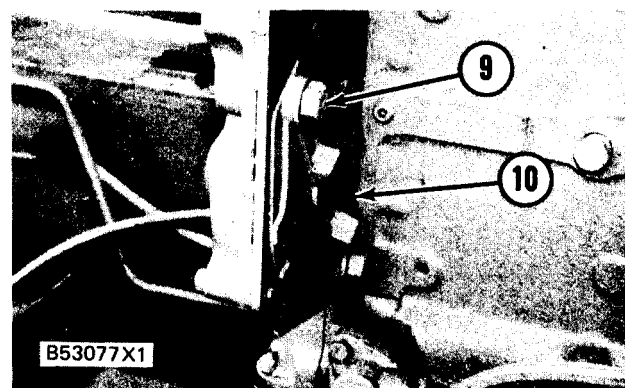
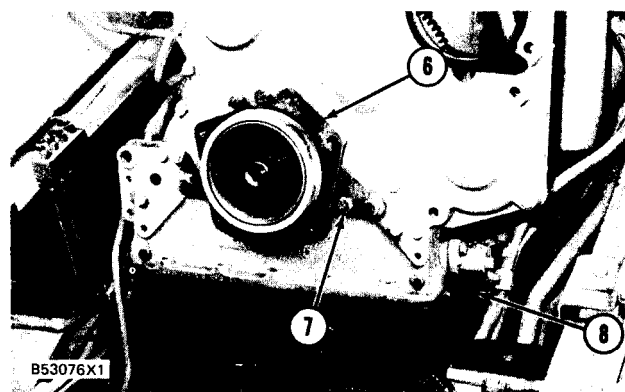
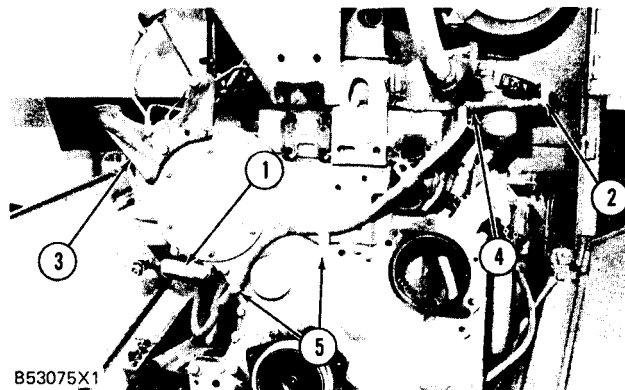

TIMING GEAR COVER

INSTALL TIMING GEAR COVER 1166-12

1. Install a new gasket on the timing gear plate. Cut the gasket even with the bottom face of the cylinder block. Put 5H2471 Gasket Cement on the bottom of the gasket where the gasket makes contact with the gasket for the oil pan plate.
2. Put timing gear cover (1) in position on the timing gear plate and install the bolts that hold it in place.

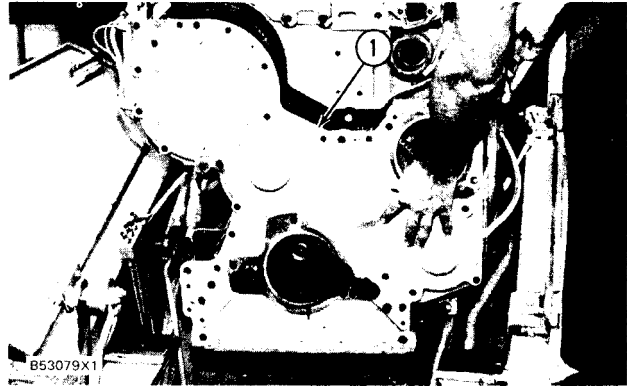

NOTE: Tighten bolts (X) to a torque of 23 ± 4 N·m (17 ± 3 lb.ft.). For location of bolts (X) see picture B53078X1 on Page 5-71.

3. Put the O-ring seal and cover (2) in position on the timing gear plate with the bolts that hold them.
4. Be sure the O-ring seal is in position on trunnion (3). Put trunnion (3) in position on the timing gear cover and install bolts (5). Tighten the bolts to a torque of 135 ± 15 N·m (100 ± 11 lb. ft.).

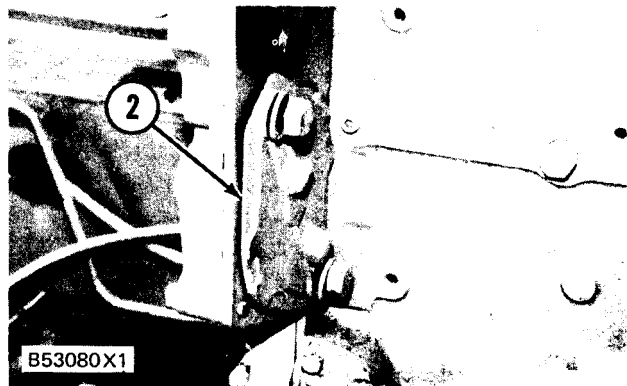

5. Remove spacers (4) from between the oil pan plate and the engine block.
6. Install alternator bracket (7) on the timing gear cover.
7. Connect the ground wire to alternator bracket (7).

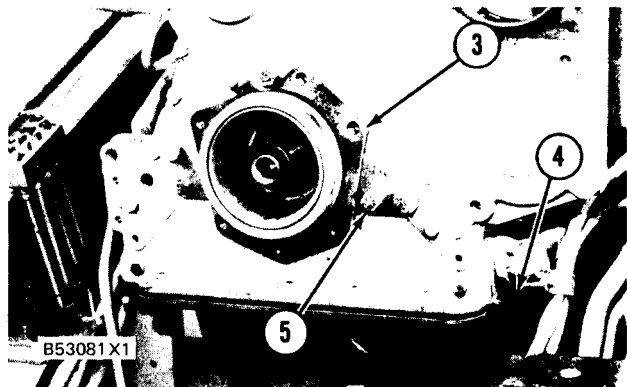

8. Install adjusting bracket (9) to the timing gear cover.
9. Connect fuel line (6) to the fuel priming pump and clips (8) that hold the fuel line to the engine end by:

- a) install engine front support
- b) install fan drive
- c) install water pump
- d) install air conditioning compressor
- e) install alternator
- f) install air compressor

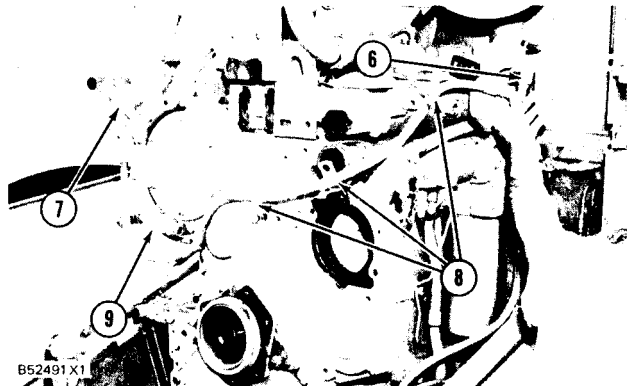

TIMING GEARS**REMOVE TIMING GEARS AND PLATE**

1206 & 1152-11

Tools Needed		A	B
8S2264	Puller Group	1	
867560	Step Plate	1	
1B3680	Bolt (3/8"-24 NF x 3 3/4 in. long)	2	
5M2894	Flat Washer (3/8 in.)	2	
1P510	Driver Group		1

start by:

a) remove timing gear cover

1. Loosen the bolt that holds gear (1) on the fuel injection pump camshaft approximately 6.35 mm (.25 in.). Install tooling (A) on gear (1) and use tooling (A) to loosen the gear on the shaft. Remove tooling (A), the bolt, washer and gear (1) from the shaft.

2. Remove bolts (3), the plate and idler gear (2) from the shaft.

3. If necessary use tool (B) and a press to remove the bearing from idler gear (2).

CAUTION

Do not turn crankshaft after camshaft gear (6) has been removed. It will cause damage to the valves.

4. Turn the crankshaft and camshaft so the "C" marks (4) are in alignment on both crankshaft gear (5) and camshaft gear (6).

5. Remove the bolts and camshaft gear (6) from the camshaft.

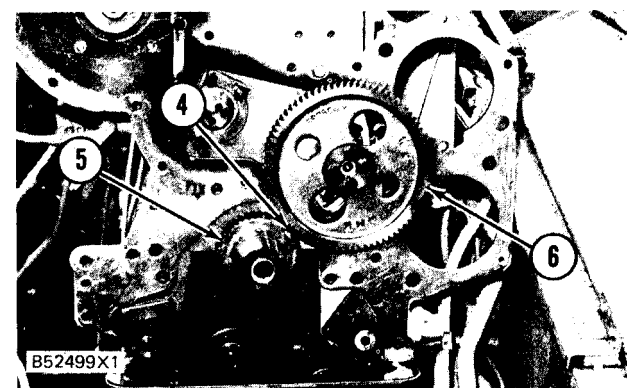
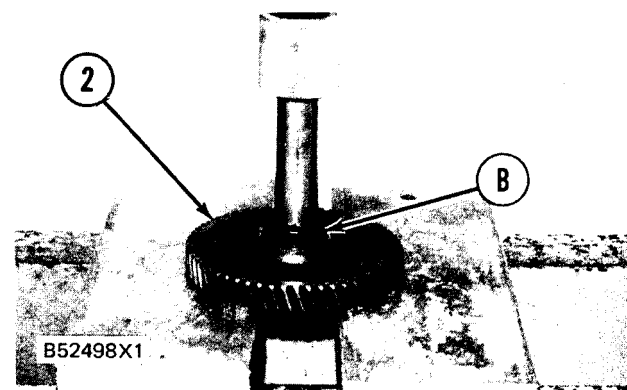
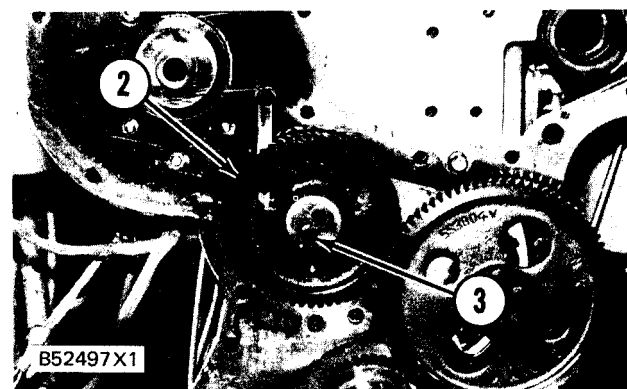
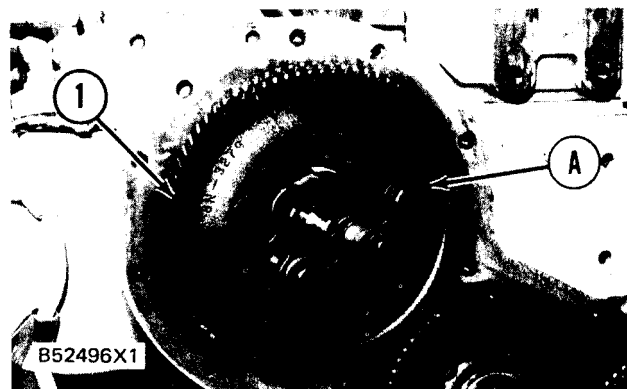

TIMING GEARS AND PLATE

6. Remove the three nuts (opposite side) from studs (7) that hold the fuel injection pump housing to the timing gear plate.

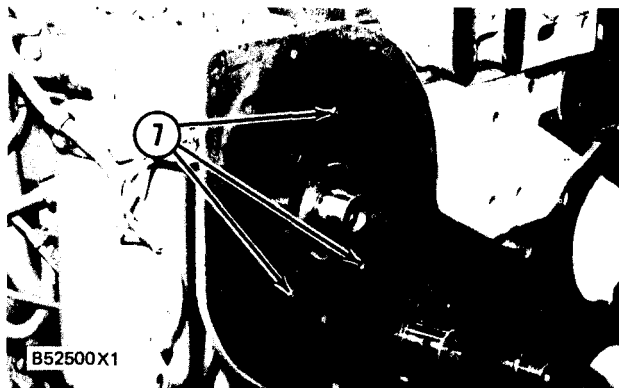

7. Remove six bolts (8), the locks and timing gear plate (9) from the engine block.

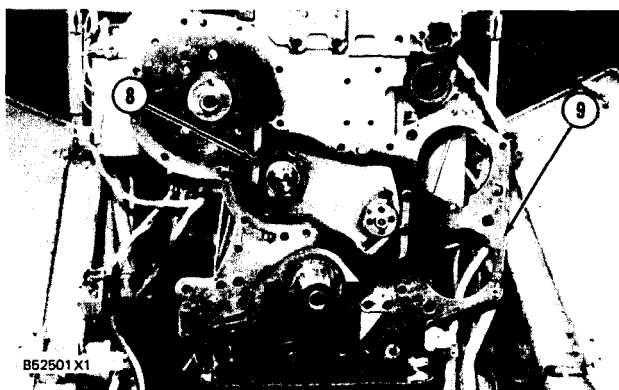

INSTALL TIMING GEARS AND PLATE

1206 & 1162-12

Tools Needed		A
1P510	Driver Group	1

1. Clean the old gasket from the contact surfaces of the timing gear plate and cylinder block. Install a new gasket on the cylinder block. Cut the gasket even with the bottom face of the cylinder block. Put 5H2471 Gasket Cement on the bottom of the gasket where the gasket makes contact with the gasket for the oil pan plate.



2. Be sure O-ring seals (1) are in position on the end of the fuel injection pump housing.

3. Put timing gear plate (2) in position on the cylinder block and install the locks and bolts that hold it in place. Install the three washers and nuts that hold the fuel injection pump housing to the back of the timing gear plate.

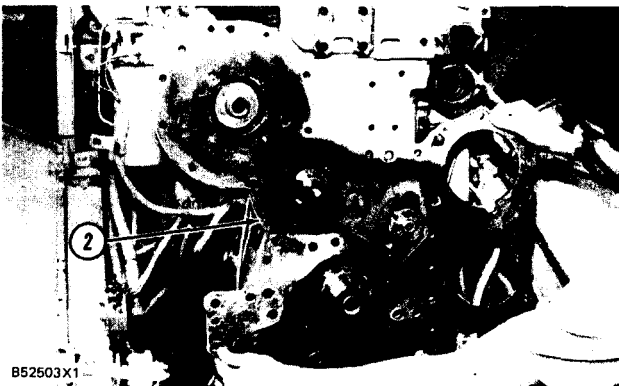

ENGINE

TIMING GEARS AND PLATE

CAUTION

After the timing gear plate is installed be sure the rack is free to move in the fuel injection pump housing. The O-ring seal on the drive end of the fuel injection pump housing can hold the rack and prevent free rack movement. Rack movement can be seen through hole (3) in the timing gear plate. If the rack does not move freely, remove the timing gear plate and check the O-ring seal on the drive end of the fuel injection pump housing.

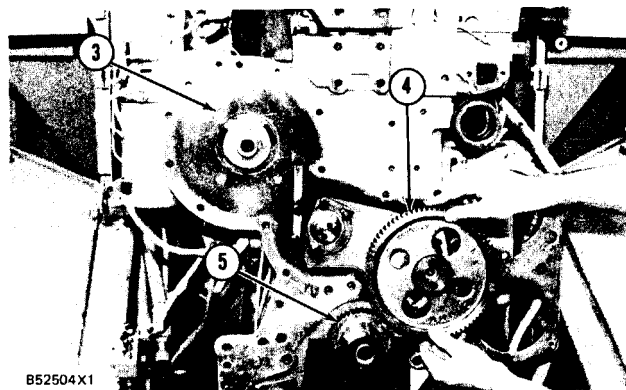

4. Install camshaft gear (4) on the camshaft so the "C" marks on both crankshaft gear (5) and camshaft gear (4) are in alignment. Install the bolts that hold camshaft gear (4) on the camshaft and tighten them to a torque of 55 ± 7 N·m (41 ± 5 lb. ft.).

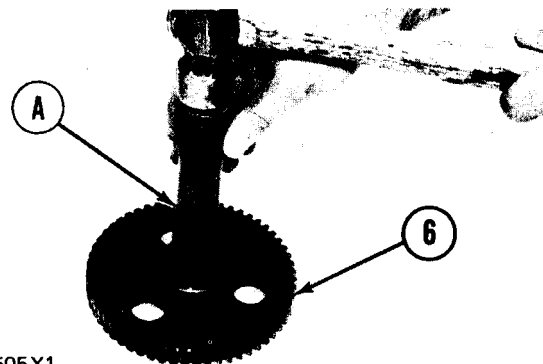

5. Use tool (A) and install the bearing in idler gear (6). The end of the bearing must be 1.52 mm (.060 in.) below the face of the gear hub.

6. Be sure the oil hole in the shaft for gear (6) is open. Install idler gear (6) on the shaft. Put the plate in position with the finished side toward gear (6) and install the bolts that hold the plate and gear (6) on the shaft.

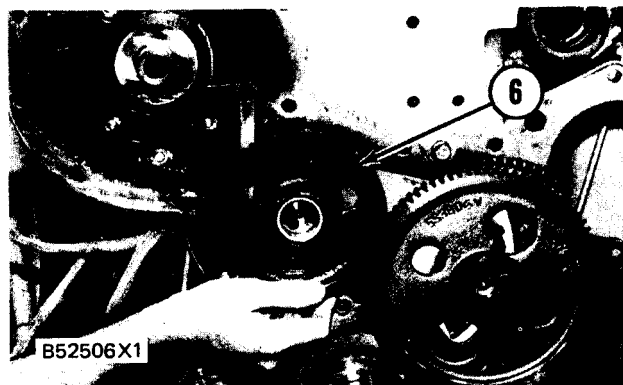

7. Put fuel injection pump drive gear (7) in position on the fuel injection pump camshaft. Install the washer and bolt that hold the gear in place but do not tighten. The flat side of the washer must be away from the gear. For correct installation of the fuel injection pump drive gear and timing of the engine, see INSTALL FUEL INJECTION PUMP HOUSING AND GOVERNOR.

end by:

- a) install timing gear cover

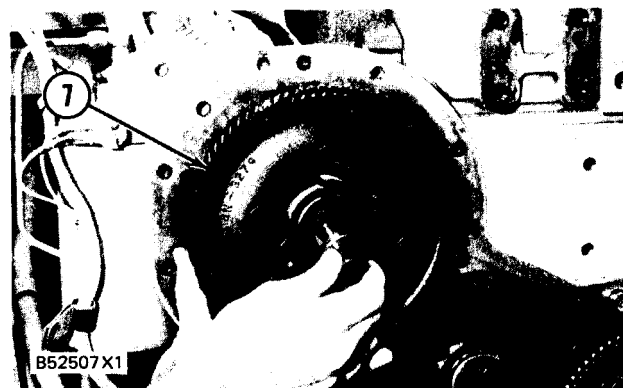

FUEL INJECTION LINES

REMOVE FUEL INJECTION LINES 1252-11

1. Disconnect fuel lines (3) from the fuel injection pump housing.
2. Remove bolts (1) that hold the fuel lines to the engine.

CAUTION

Do not let the tops of fuel nozzles turn when the fuel lines are loosened. The nozzles will be damaged if the top of the nozzle turns in the body. The engine will be damaged if a defective fuel injection nozzle is used because the shape of fuel (spray pattern) that comes out of the nozzles will not be correct.

3. Use two wrenches, one to hold the fuel nozzles so they will not turn and one to disconnect fuel lines (2) from the nozzles.
4. Remove the fuel lines from the engine.
5. Put caps and plugs on the nozzles, fuel lines and fuel injection pump housing to keep dirt out of the fuel system.

INSTALL FUEL INJECTION LINES 1252-12

1. Make sure the fuel injection lines are clean and dry.
2. Put fuel injection lines (1) in position and connect them to the fuel injection pump housing.

CAUTION

Do not let the tops of fuel nozzles turn when the fuel line nuts are tightened. The nozzles will be damaged if the top of the nozzle turns in the body. The engine will be damaged if a defective fuel injection nozzle is used because the shape of fuel (spray pattern) that comes out of the nozzles will not be correct.

3. Use a wrench to hold the nozzles so they will not turn and connect fuel lines (1) to the nozzles. Tighten the fuel lines to a torque of 40 ± 7 N·m (30 ± 5 lb.ft.).
4. Install bolts (2) that hold the fuel lines to the engine.
5. Remove (bleed) the air from the fuel system. See MAINTENANCE GUIDE.

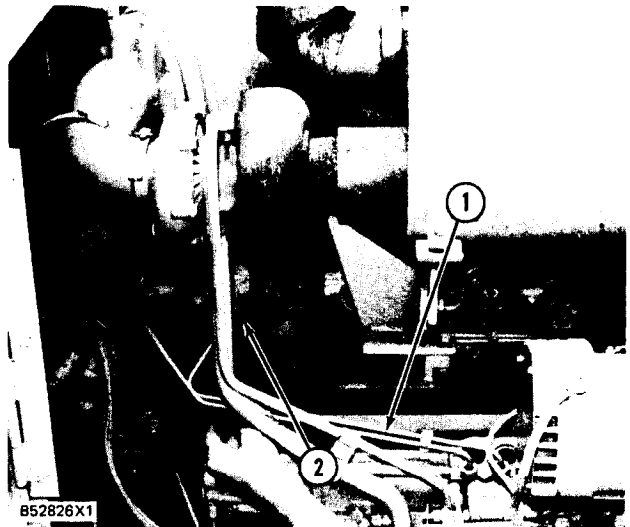
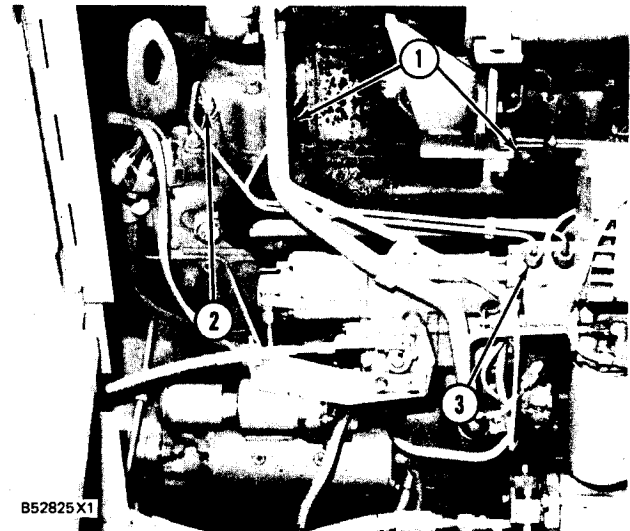

FUEL INJECTION NOZZLES

REMOVE FUEL INJECTION NOZZLES 1254-11

Tools Needed		A	B
6V3129	Nozzle Puller Group	1	
FT 1533	Nozzle Puller Adapter		1
1P74	Slide Hammer		1

start by:

- a) remove fuel injection lines

CAUTION

Do not let the tops of the fuel nozzles turn when the fuel lines are loosened. The nozzles will be damaged if the top of the nozzle turns in the body.

1. Remove bolt (1) and the clamp.
2. Install tooling (A) on fuel injection nozzle (2). Make sure the bottom of the screw in tooling (A) is in alignment with the hole for bolt (1).

CAUTION

Do not exceed a torque of 17 N-m (150 lb.in.) on the screw in tooling (A) to remove the nozzle.

3. If the nozzle can not be removed with tooling (A), tooling (B) must be used.
4. To remove the nozzles with tooling (B), remove any components necessary to give better access.
5. Remove the carbon dam seal on the end of the nozzle.

INSTALL FUEL INJECTION NOZZLES 1254-12

Tools Needed		A
6V4979	Carbon Stop Seal Tool	1

1. Use tool (A) to install carbon dam seal (2) on nozzle (1).
2. Put nozzles(1) in position with bleed screw (3) away from the valve cover.
3. Install the clamp and bolt. Make an alignment with the clamp and the openings in the nozzle.

CAUTION

Do not let the tops of the fuel nozzles turn when the fuel lines are tightened. The nozzles will be damaged if the top of the nozzle turns in the body.

end by:

- a) install fuel injection lines

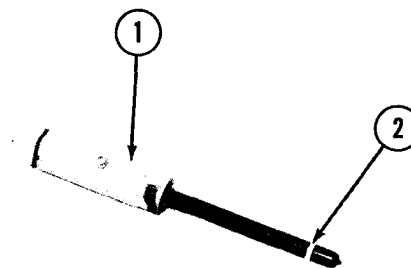
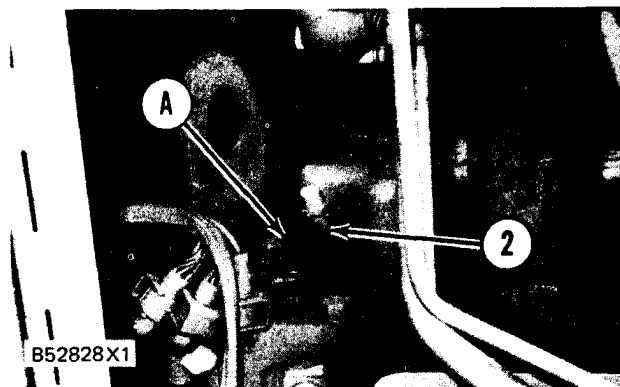
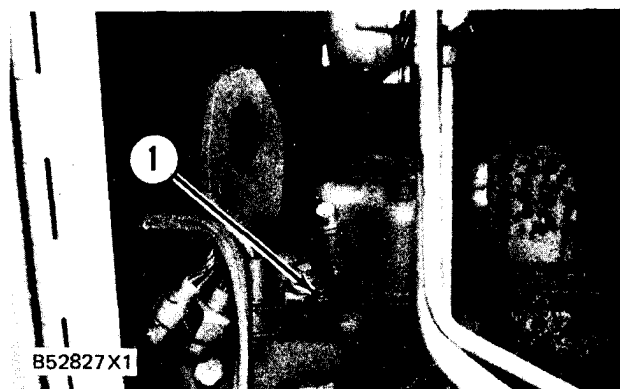

B52829X1

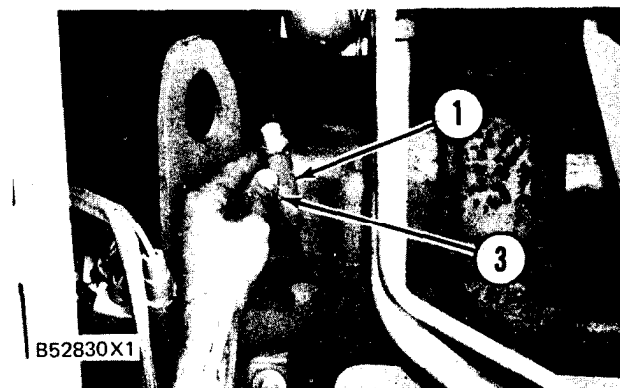

FUEL INJECTION PUMPS

DISASSEMBLE FUEL INJECTION PUMPS

1251-15

start by:

- a) remove fuel injection pumps

CAUTION

Be careful when the injection pumps are disassembled. Do not damage the surfaces of the plungers, barrels and bonnets. Any scratches will cause leakage inside the fuel injection pump. The plunger and barrel for each pump are made as a set. Do not put the plunger of one pump in the barrel of another pump. If one part has wear, install a complete new pump assembly. Be careful when the plunger is put into the bore of the barrel.

1. Pull plunger (1) and washer (5) out of barrel (3) and spring (2).
2. Remove washer (5) from plunger (1).

CAUTION

Do not remove the gear from the plunger. The gear and plunger are assembled and adjusted at the factory.

3. Remove spring (2) from barrel (3).
4. Remove ring (6) and make a separation of barrel (3) and bonnet (4).
5. Remove check assembly (7) and spring (8) from bonnet (4). If check assembly (7) is disassembled, do not mix parts with parts from another check assembly.

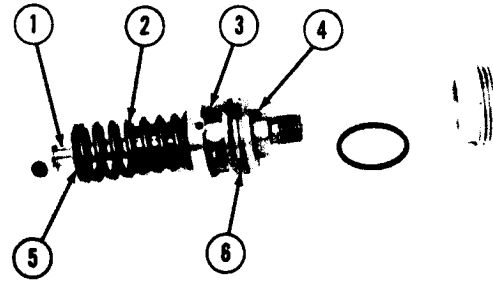

B6275X1

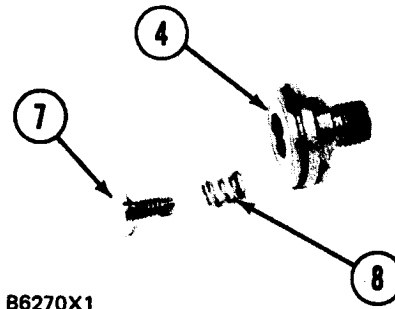

B6270X1

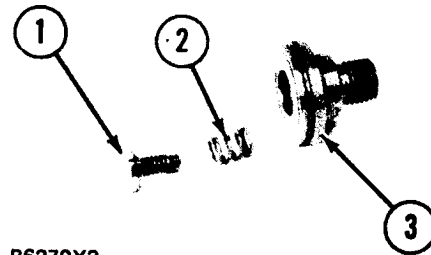

B6270X2

ASSEMBLE FUEL INJECTION PUMPS

1251-16

CAUTION

Put clean fuel oil on all parts during assembly.

1. Install spring (2) and check assembly (1) in bonnet (3).
2. Install bonnet (3) on barrel (4) and install ring (5) to hold them together. Do not slide bonnet (3) across barrel (4) because check assembly (1) in the bonnet can cause damage to the face of barrel (4).
3. Install spring (8) on barrel (4).
4. Install washer (7) on plunger (6) with the flat side toward the gear on the plunger.
5. Install plunger (6) in barrel (4) until washer (7) is engaged in the spring.

end by:

- a) install fuel injection pumps

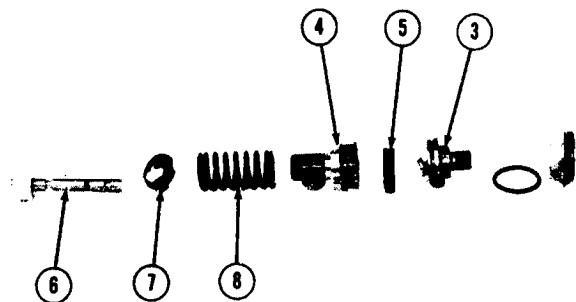

B6269X1

EXHAUST MANIFOLD**REMOVE EXHAUST MANIFOLD**

1059-11

start by:

- a) remove muffler
- b) remove turbocharger
- c) remove fuel injection lines

1. Remove the bolts, nuts and muffler bracket (1) from the exhaust manifold.
2. Remove nut (2), the bolt and heat shield (3) from the engine.
3. Remove spacers (6), nuts (5) and the washers that hold exhaust manifold (4) to the engine.
4. Remove exhaust manifold (4) and the gaskets.

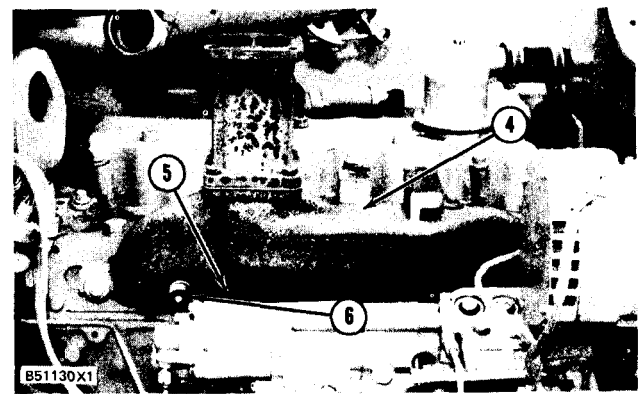
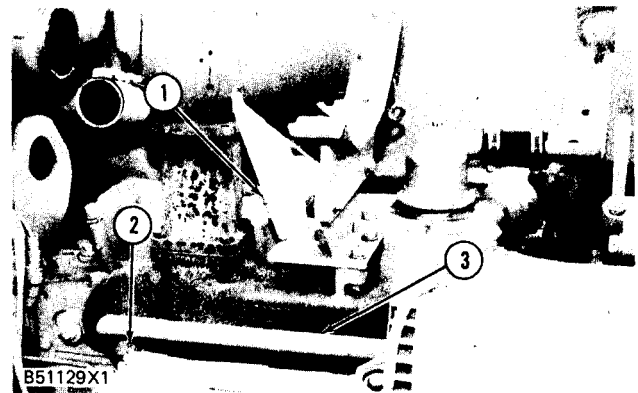
**INSTALL EXHAUST MANIFOLD**

1059-12

1. If a replacement of studs (1) is necessary, put 5P3931 Anti-Seize Compound on the threads of the studs. Install the new studs and tighten to a torque of 27 ± 4 N·m (20 ± 3 lb. ft.).
2. Install new gaskets on the studs with the tabs toward the front of the engine.
3. Put 5P3931 Anti-Seize Compound on the threads of the studs and nuts.
4. Put exhaust manifold (2) in position on the engine and install the washers and nuts.
5. Install spacers (4) on the stud.
6. Install heat shield (5) on the engine.
7. Install muffler bracket (3) on the exhaust manifold.

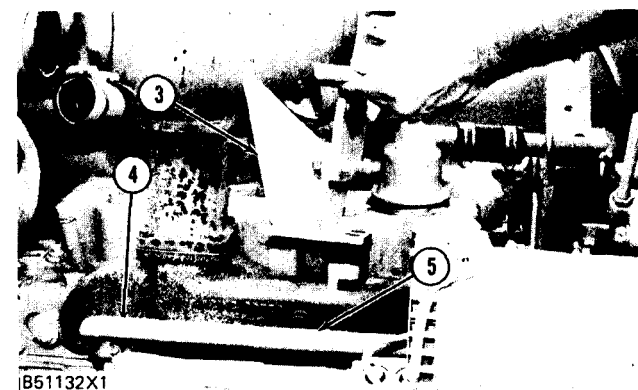
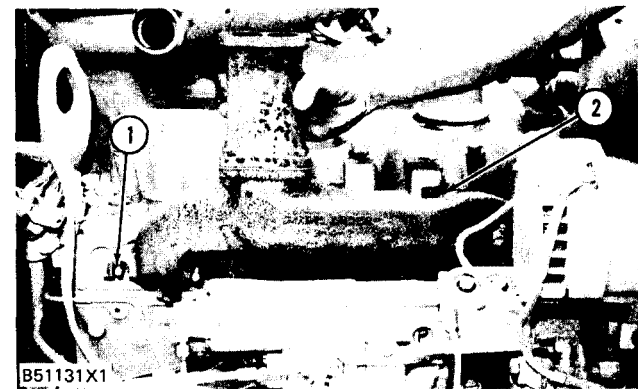

end by:

- a) install muffler
- b) install turbocharger
- c) install fuel injection lines

FUEL SHUTOFF SOLENOID AND FUEL RATIO CONTROL

REMOVE AND INSTALL SHUTOFF SOLENOID 1259-10

NOTE: The fuel ratio control was removed for photo illustration only. Models 950BNS and 950BS are shown. Procedure same for all models.

1. Put identification on wires (2) and disconnect them from fuel shutoff solenoid (1).
2. Remove the bolts and fuel shutoff solenoid (1) from the governor.

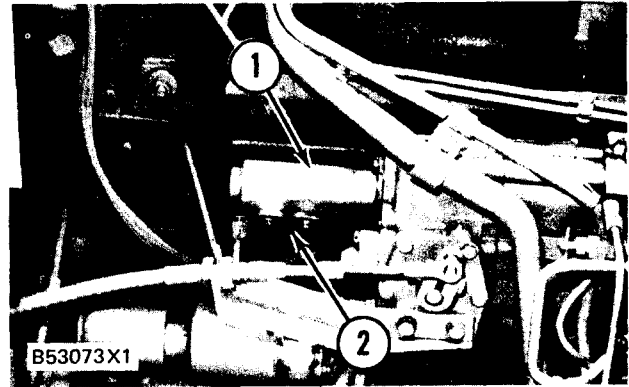

NOTE: The following steps are for installation.

1. Put the gasket and fuel shutoff solenoid (1) in position on the governor and install the bolts.
2. Connect the wires on fuel shutoff solenoid (1).

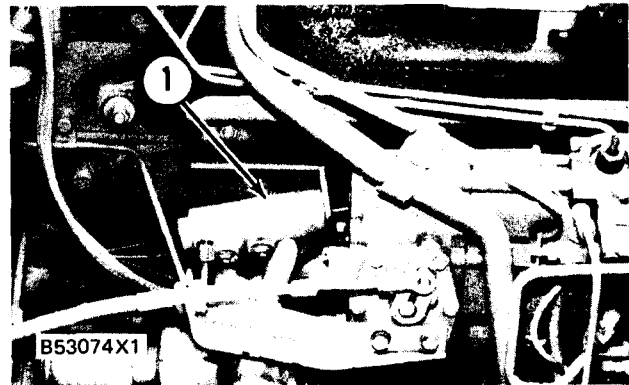

REMOVE AND INSTALL FUEL RATIO CONTROL 1278-10

1. Disconnect tube (2) from fuel ratio control (1).
2. Remove the two bolts that hold fuel ratio control (1) to the governor.
3. Make sure the stem on the fuel ratio control is disengaged from the lever in the governor. Remove fuel ratio control (1) from the governor.
4. Inspect and make a replacement if necessary of the-screen assembly and three O-ring seals on the governor housing and O-ring seal on the fuel ratio control.

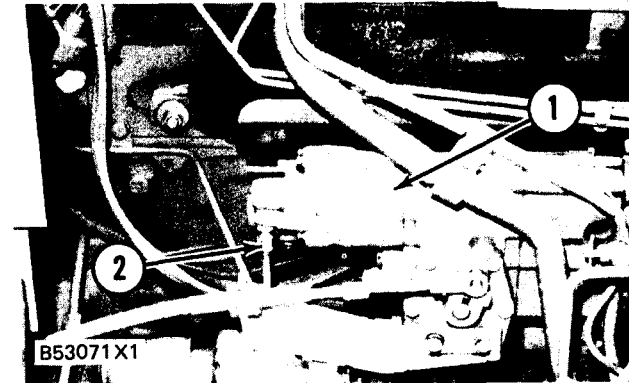

NOTE: The following steps are for installation.

5. Put fuel ratio control (1) in position on the governor. Make sure the stem fits into the (slot) groove in the lever. Install the bolts.
6. Connect the tube assembly to the fuel ratio control.
7. Make an adjustment to the fuel ratio control See TESTING AND ADJUSTING.

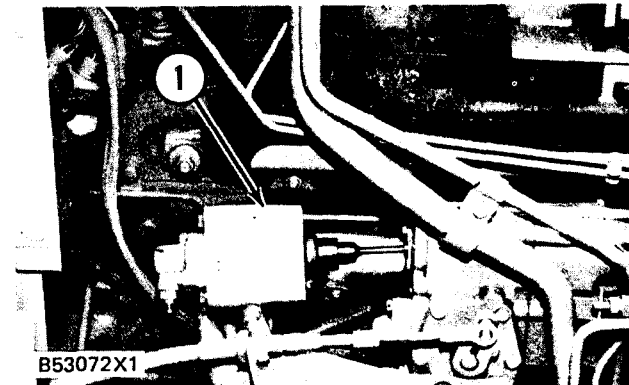

FUEL RATIO CONTROL

DISASSEMBLE THE FUEL RATIO CONTROL

1278-15

Tools Needed		A
1P1859	Snap Ring Pliers	1

start by:

a) remove fuel ratio control

1. Remove bolts (2) which hold cover (1) to housing (3). Be careful when bolts (2) are removed because cover (1) is under spring force.
2. Make a separation of the components of the fuel ratio control: cover (1), spring (4), valve (5), spring (6), retainer (7), spring (8), valve assembly (9) and housing (3).
3. Make a separation of the covers (1).
4. Remove nut (11) and stop (10) from the cover for models 950BNS and 950BS only.

NOTE: Washer (13) is not used on models 950 BNSCE and 950BSCE.

5. Remove nut (12) and make a separation of nut (12), washer (13), washer (14), diaphragm (15), valve extension (17), spring (16) and valve (18).

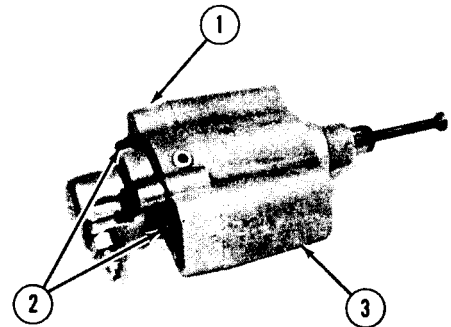

B40206X1

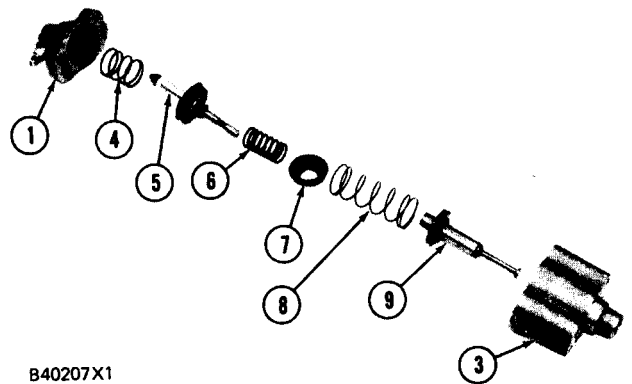

B40207X1

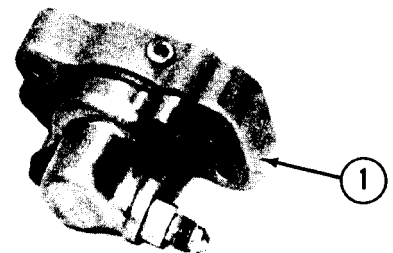

B40208X1

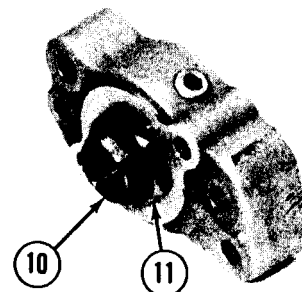

B40209X1

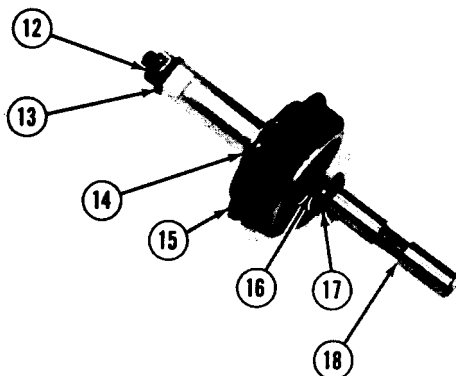

B40210X1

FUEL RATIO CONTROL

6. Use tooling (A) to remove snap ring (19).
7. For models 950BNSCE and 950BSCE only, remove two washers (22) behind snap ring.
8. Remove piston (20) from valve (18).
9. Remove seal (21) from piston (20).
10. Inspect all parts and make replacements if necessary.

ASSEMBLE THE FUEL RATIO CONTROL

1278-16

Tools Needed		A
1P1859	Snap Ring Pliers	1

1. Put seal (1) on piston (2). Install the seal so the lip is toward the direction of the center of piston (2).
 2. Put piston (2) on valve assembly (3). For models 950BNSCE and 950BSCE only, put two washers (22) on valve assembly.
 3. Use tooling (A) to put the snap ring (4) in position.
 4. Put O-ring seal (5) in position on valve extension (6).
 5. Put diaphragm (10) on retainer (13). The outer lip of the diaphragm must be toward the hole with thread.
- NOTE: Spacer (12) is not used on models 950BNSCE and 950BSCE.
6. Put engine oil on the seal (5) on valve extension (6) and put valve extension (6) into retainer (13). Install spacer (12) and nut (11).
 7. Put spring (7) into valve extension (6) and engage internal valve (8) with hook on the valve extension (6).
 8. Put washer (9) on diaphragm (10). The flat side of washer (9) must be in contact with diaphragm (10). For models 950BNSCE and 950BSCE, put larger diameter of washer in contact with diaphragm.

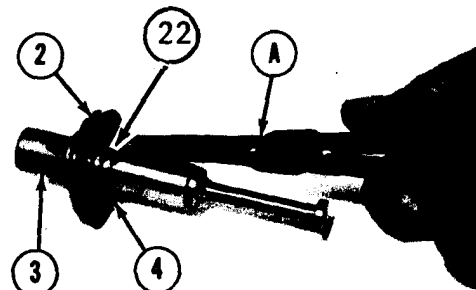
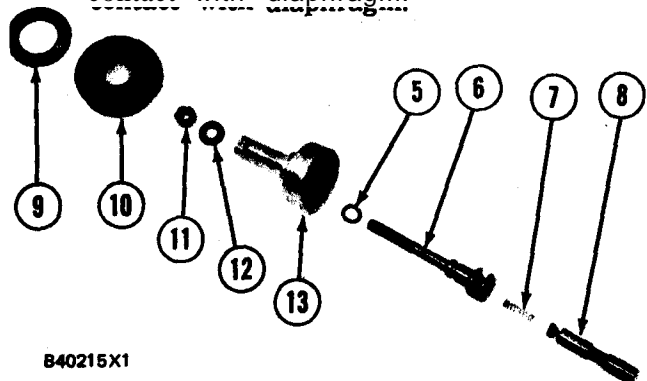
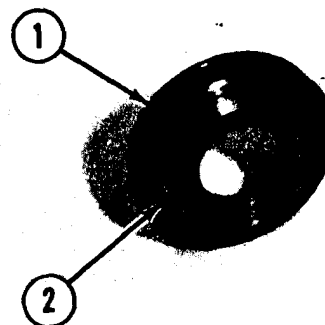
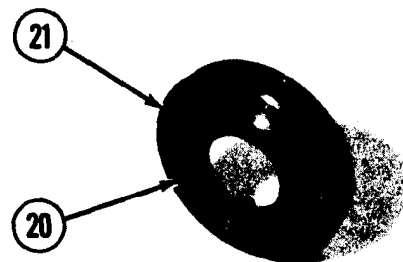
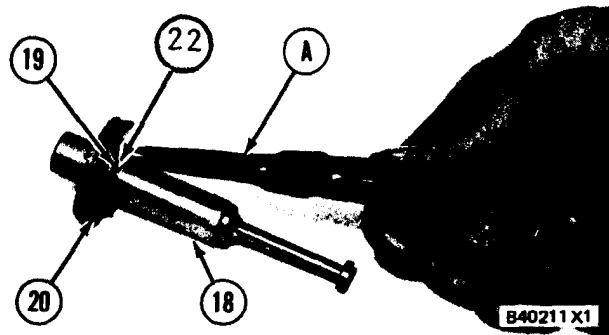

FUEL RATIO CONTROL

9. For models 950BNS and 950BS only, put stop (15) in cover (17). Put nut (16) on stop (15).
10. Make a replacement of the gasket on cover (14). Put cover (14) on cover (17) and install the bolts which hold the covers together.
11. Put engine oil on the seal on valve assembly (3) and put valve assembly (3) into housing (22).
12. Put spring (21) on valve assembly (3).
13. Engage retainer (20) with spring (21). Put spring (19) into retainer (20).
14. Put engine oil on valve (8) and put retainer (13) into housing (22). Engage internal valve (8) into valve assembly (3).
15. Put spring (18) into the open face of the washer behind the diaphragm.
16. Put cover (17) against housing (22). Make sure the ring on the diaphragm is engaged with the groove in cover (17).

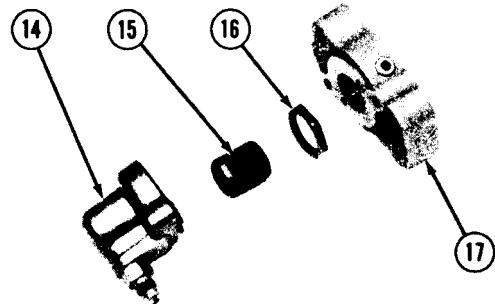

B40216X1

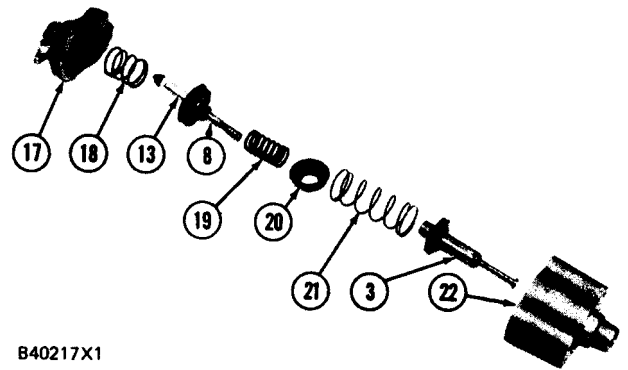

B40217X1

Cross Section For Models 950BNS and 950 BS.

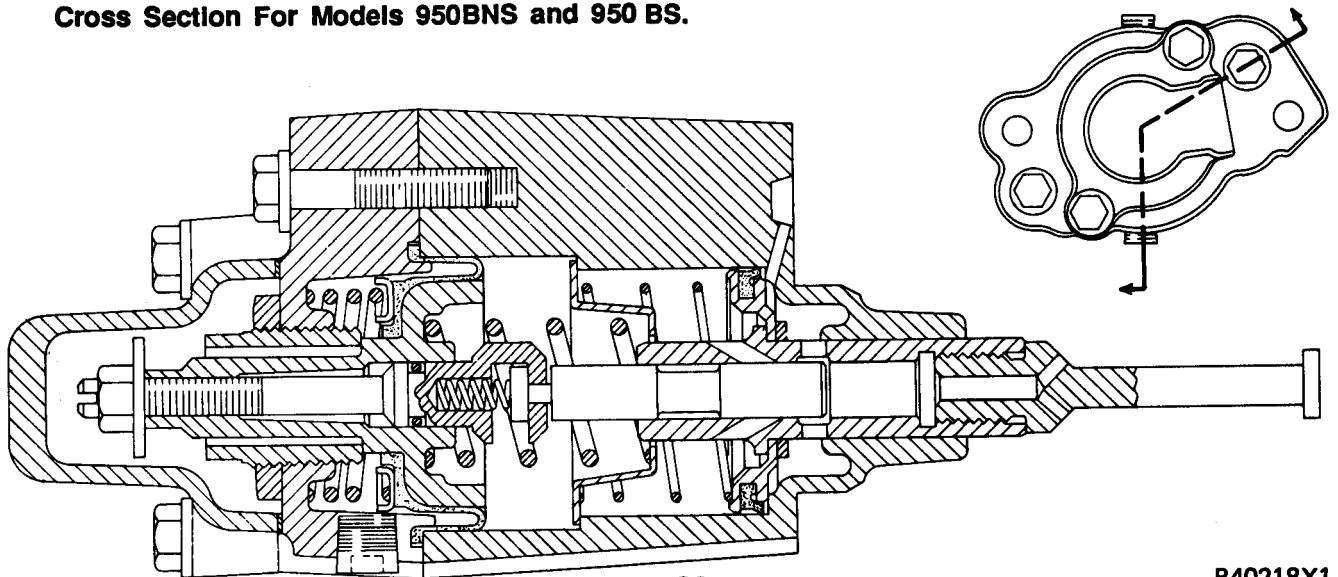

5-83

B40218X1

ENGINE

FUEL RATIO CONTROL

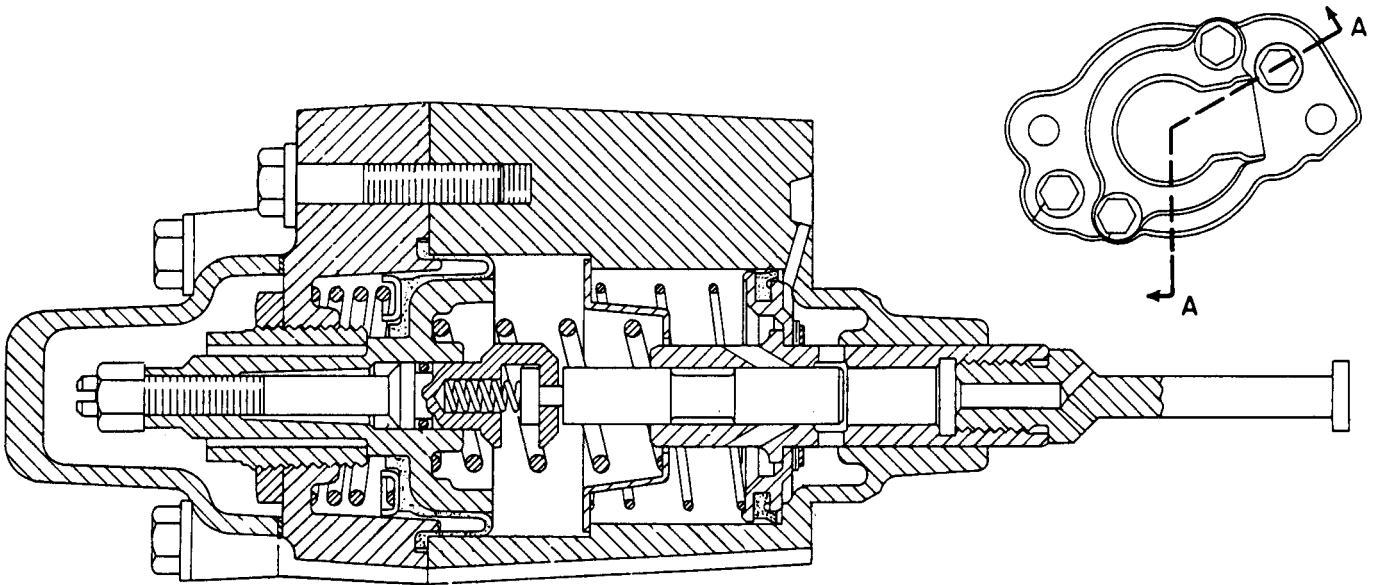

Cross Section for Models 950BNSCE and 950BSCE

NOTE: Refer to Chapter 4 for fuel ratio control adjustment.

end by:

- a) install fuel ratio control

FUEL PRIMING AND PRIMARY FILTER PUMP GROUP

REMOVE FUEL PRIMING AND PRIMARY FILTER PUMP GROUP 1260 & 1258-11

1. Disconnect fuel lines (1) from the fuel filter base.

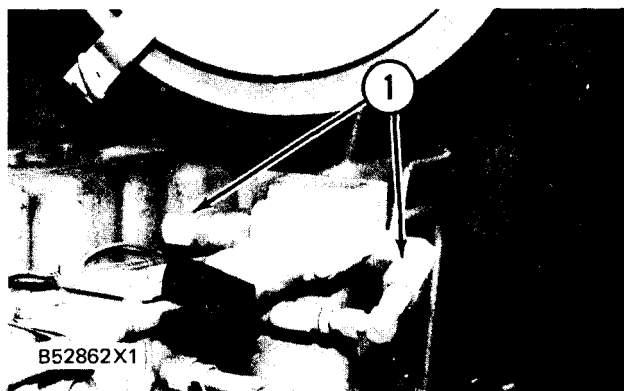

2. Remove two bolts (3) and fuel filter base assembly (2).

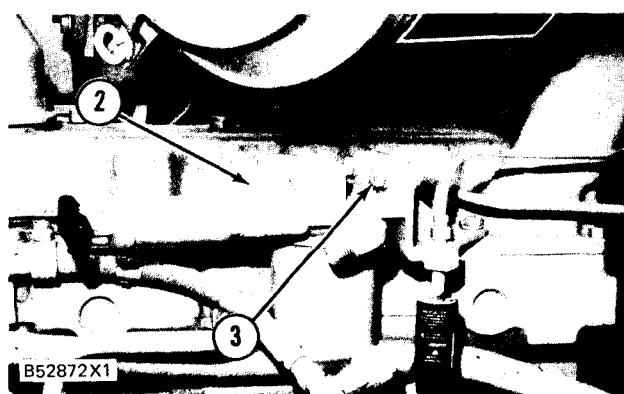

INSTALL FUEL PRIMING AND PRIMARY FILTER PUMP GROUP 1260 & 1258-12

1. Put fuel filter base assembly (1) into position as shown and install the bolts.

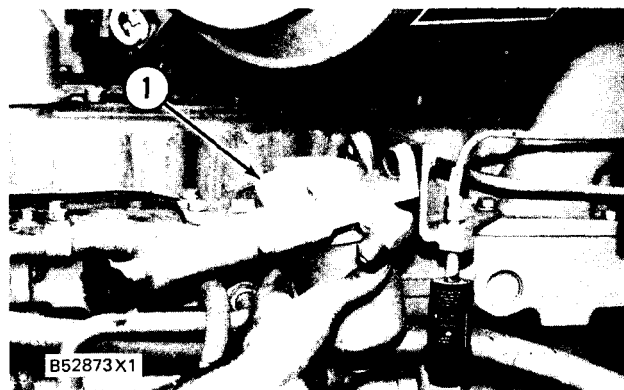

2. Connect fuel lines (2) to the fuel filter base assembly as shown.

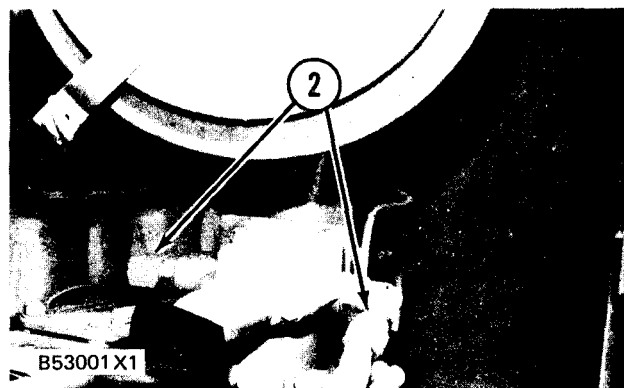

FUEL PRIMING AND PRIMARY FILTER PUMP GROUP

DISASSEMBLE FUEL PRIMING AND PRIMARY FILTER PUMP GROUP 1260 & 1258-15

Tools Needed		A
1P1855	Snap Ring Pliers	1

start by:

a) remove fuel priming and primary filter pump group

1. Remove two bolts (1) and primary pump (2) from the filter base.
2. Remove case assembly (7) from base assembly (9).
3. Remove filter element (5) from case assembly (7).

CAUTION

Spring (11) is held in compression behind retainer (6).

4. Use tool (A) to remove ring (10).
5. Remove retainer (6) and spring (11) from case assembly (7).
6. Use tool (A) to remove ring (4) from nut (3).
7. Remove nut (3) from base assembly (9).
8. Remove O-ring seal (8) from nut (3).

ASSEMBLE FUEL PRIMING AND PRIMARY FILTER PUMP GROUP 1260 & 1258-16

Tools Needed		A
1P1855	Snap Ring Pliers	1

1. Install O-ring seal (2) on nut (1).
2. Install nut (1) in base assembly (7).
3. Use tool (A) to install ring (3) on nut (1).
4. Install spring (5) and retainer (9) in case assembly (6).
5. Use tool (A) to install ring (4) in the groove on the shaft of case assembly (6).
6. Install filter element (8) in case assembly (6) and install case assembly (6) on base assembly (7).
7. Put primary pump (10) and the gasket in position on the filter base and install the bolts.

end by:

a) install fuel priming and primary filter pump group

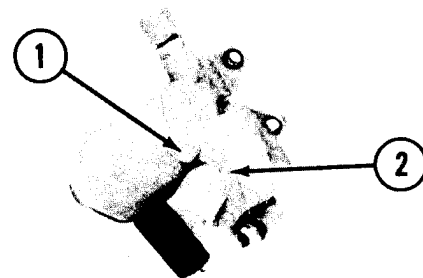

B51137X1

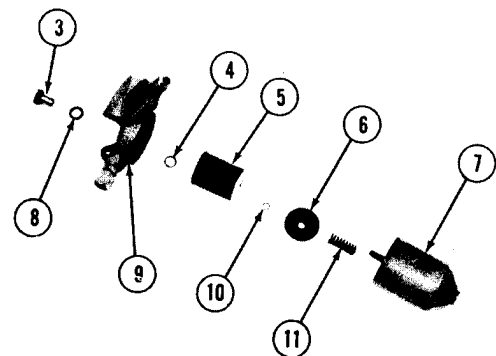

B51138X1

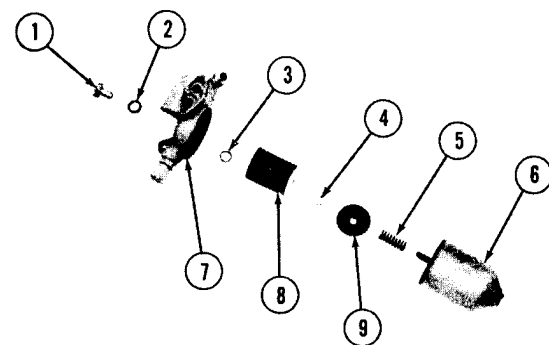

B51139X1

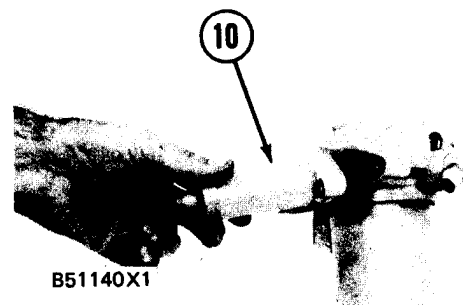

B51140X1

FUEL TRANSFER PUMP

REMOVE FUEL TRANSFER PUMP 1256-11

Tools Needed		A
2P8250	Strap Wrench	1

NOTE: Models 950BNS and 950BS Fuel Transfer Pump is shown. Procedures are the same for 950BNSCE and 950BSCE.

1. Use tool (A) and remove fuel filter (1) from the fuel filter base.
2. Remove transfer pump outlet fuel line (2). Disconnect transfer pump inlet fuel line (4) from fuel transfer pump (3).
3. Remove the bolts and remove fuel transfer pump (3).

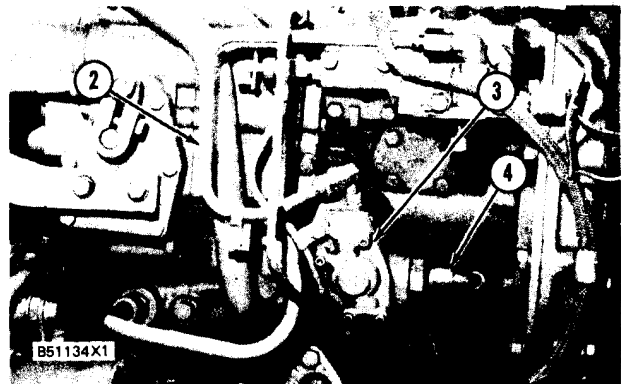
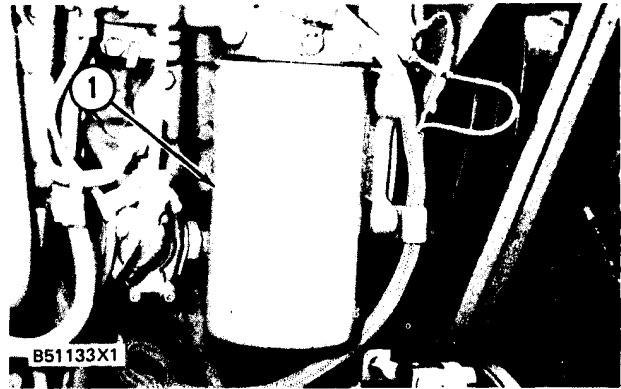

INSTALL FUEL TRANSFER PUMP 1256-12

1. Be sure the O-ring seal is in position on the fuel transfer pump and put clean oil on the O-ring seal.
2. Put fuel transfer pump (1) in position on the fuel injection pump and install the bolts.
3. Install transfer pump outlet fuel line (2) and connect transfer pump inlet fuel line (3) to the fuel transfer pump.
4. Put clean diesel fuel on the filter gasket and install by hand. Tighten ½ turn after gasket makes contact with the base.

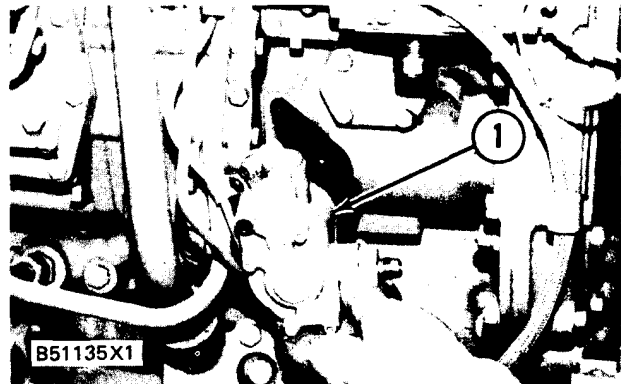

ENGINE

FUEL TRANSFER PUMP

Models 950 BNS and 950BS

DISASSEMBLE FUEL TRANSFER PUMP

1256-15

start by:

- a) remove fuel transfer pump

WARNING

Cover (2) is under spring tension. To prevent possible personal injury carefully remove bolts (1).

1. Carefully remove bolts (1) and cover (2) from the fuel transfer pump.

Remove spring (3), valve (4) and O-ring seals (5) from the cover.

Remove springs (6) and (7) from the pump housing.

4. Remove sleeve (8) from the pump housing.

5. Remove sleeve (12), piston (16), O-ring seal (11) and piston (9) from sleeve (8). Remove plate (15), valve (10) and seal (14) from piston (9). Remove O-ring seal (13) from sleeve (8).

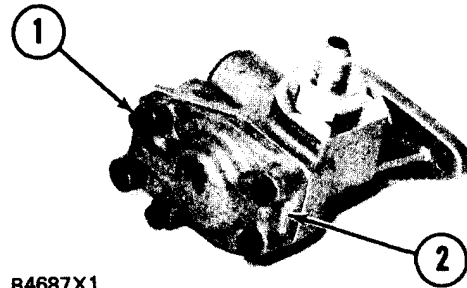

B4687X1

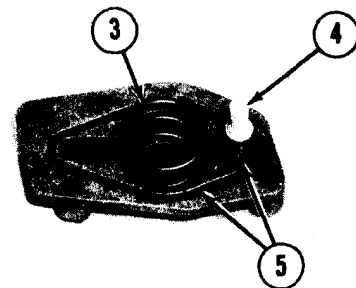

B13664X1

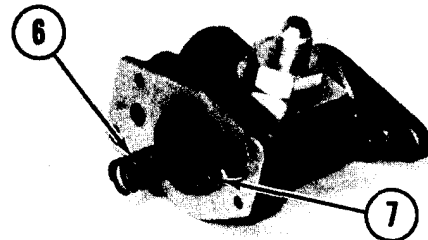

B4690X1

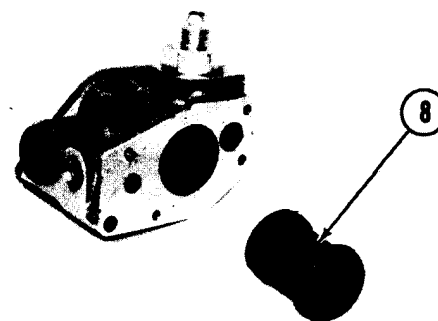

B4691X1

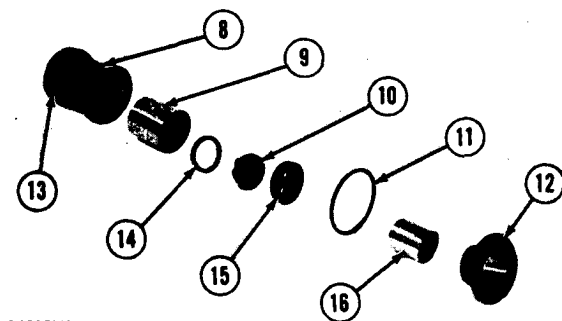

B4692X1

6. Remove O-ring seal (17) from the pump housing.
7. Push guide (18) through the pump housing and remove guides (23) and (18) together. Remove rod (20), guide (23), O-ring seal (19) and tappet (21) from guide (18). Remove ring (22) from tappet (21).

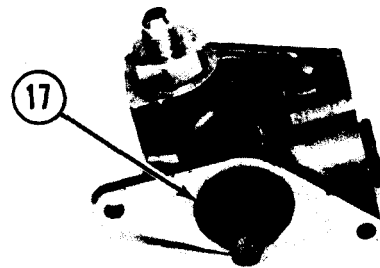

B4693X1

8. Remove connector (24), valve (26) and seal (25) from the pump housing.
9. Remove plug (30), spring (28), valve (29) and seal (27) from the pump housing.

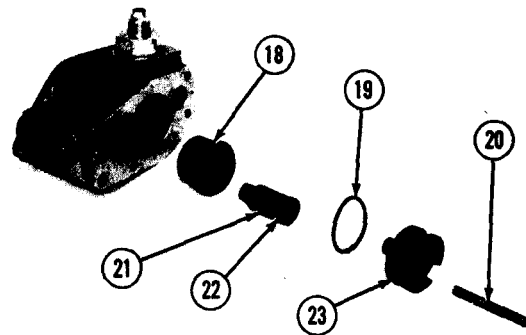

B4694X1

ASSEMBLE FUEL TRANSFER PUMP 1256-16

1. Clean all parts and be sure all passages are open.
2. Be sure the O-ring seal is in position on plug (4) and put 4L7464 Silicone Grease on the O-ring seal.

NOTE: Valves (2), (6) and (19) must be installed as shown, for the pump to operate correctly.

3. Install seal (1), valve (2), spring (3) and plug (4) in the pump housing as shown. Tighten plug (4) to a torque of 20 ± 7 N·m (15 ± 5 lb. ft.).

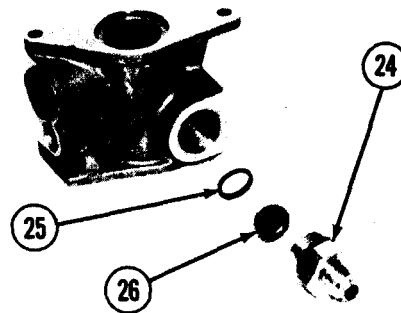

B4695X1

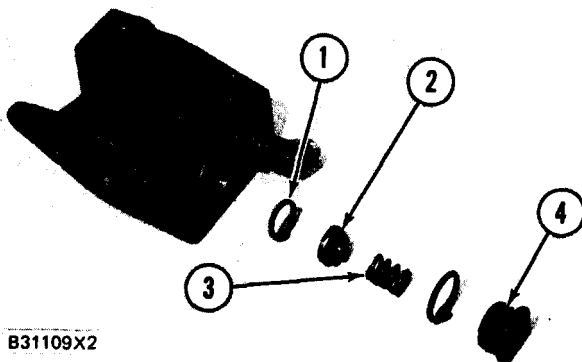

B31109X2

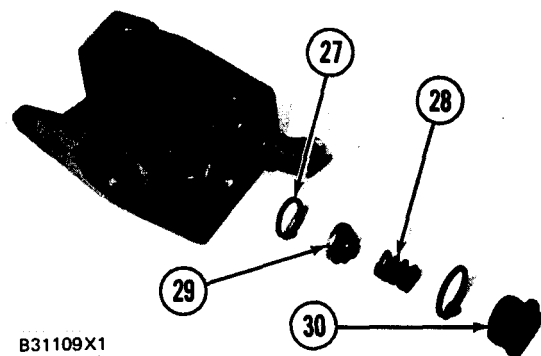

B31109X1

FUEL TRANSFER PUMP

Models 950BNS and 950BS

4. Be sure the O-ring seal is in position on connector (7) and put 4L7464 Silicone Grease on the O-ring seal.

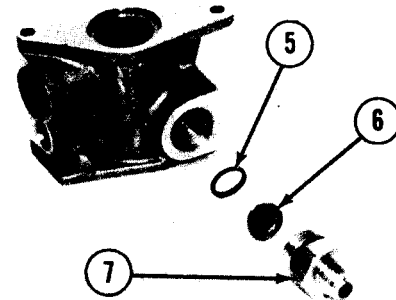

B4695X2

5. Install seal (5), valve (6) and connector (7) in the pump housing as shown. Tighten connector (7) to a torque of 55 ± 10 N·m (40 ± 7 lb.ft.).

6. Install the ring on tappet (8). Install tappet (8), O-ring seal (12), guide (9) and rod (10) in guide (11). Put 4L7464 Silicone Grease on O-ring seal (12). Install guides (11) and (9) as a unit in the pump housing as shown.

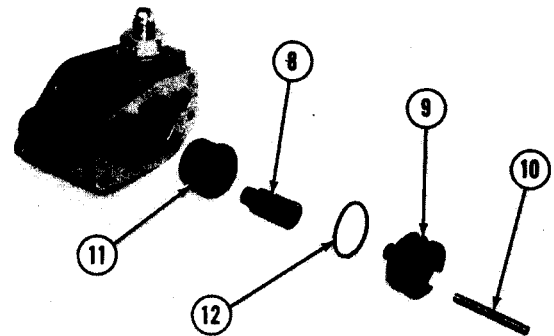

B4694X2

7. Install O-ring seal (13) in the pump housing and put 4L7464 Silicone Grease on the O-ring seal.

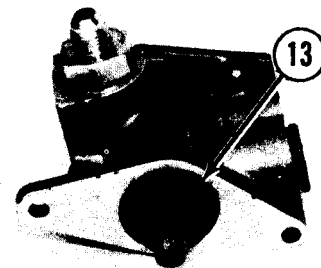

B4693X2

8. Install seal (15), valve (19) and plate (16) in piston (14) as shown. Install piston (14), O-ring seal (17), piston (20) and guide (21) in guide (18) as shown. Install the O-ring seal on guide (18) and put 4L7464 Silicone Grease on O-ring seal (17) and the O-ring seal on guide (18).

9. Install guide (18) in the pump housing as shown.

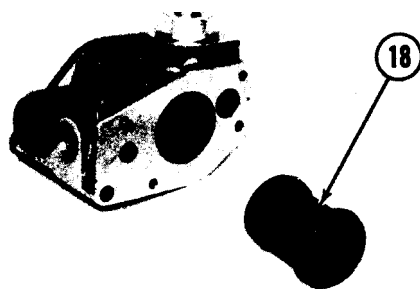

B4691X2

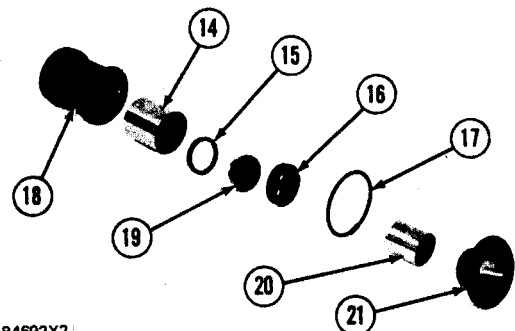

B4692X2

FUEL TRANSFER PUMP

Models 950BNS and 950BS

10. Install springs (19) and (20) in the pump housing as shown.

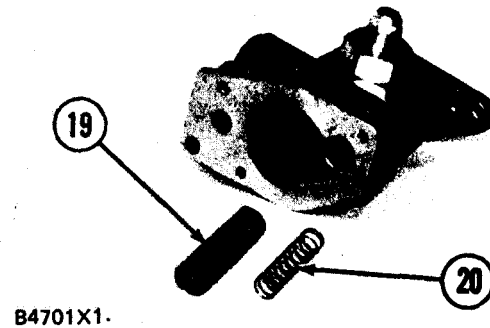

11. Install O-ring seals (22) and (21) in the cover as shown. Put 4L7464 Silicone Grease on the O-ring seals.

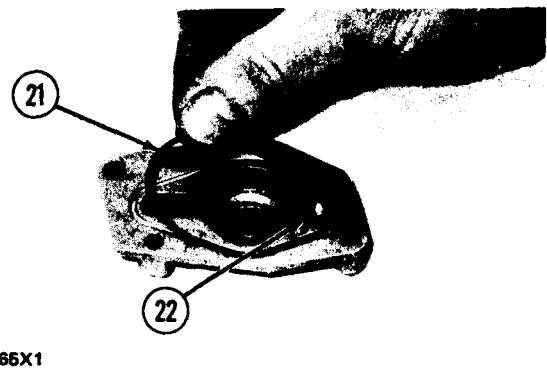

12. Install spring (23) in the cover, Install valve (24) in the cover with the grooves in the valve toward the cover.

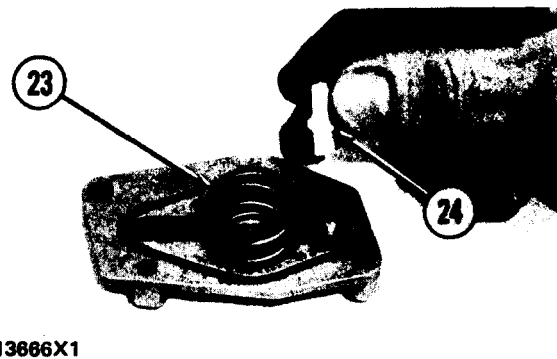

13. Put cover (25) in position on the pump housing and install the bolts that hold it in place.
end by:
a) install fuel transfer pump

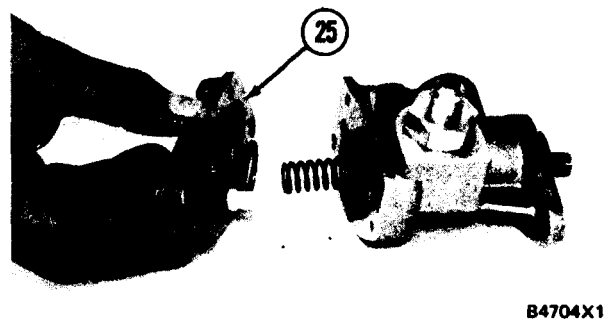

FUEL TRANSFER PUMP

Models 950BNSCE and 950BSCE

DISASSEMBLE FUEL TRANSFER PUMP

start by:

- a) remove fuel transfer pump

WARNING

Cover (2) is under spring tension. To prevent possible personal injury, carefully remove screws (1).

1. Remove two screws (1) that hold cover (2) to housing (3). Remove cover, valve (4), spring (5), washer (6), valve (7), and seal (8). Remove preformed packings (9 and 10) from cover.
2. Remove sleeve (11) and piston (12). Remove preformed packing (13) from sleeve.
3. Remove tappet assembly (14), and preformed packing (15).
4. Remove two screws (16), cover (17), preformed packing (18) and valve (19) from housing.
5. Remove preformed packing (20) from housing.

ASSEMBLE FUEL TRANSFER PUMP

1. Clean all parts and be sure all passages are open.
2. Install O-ring (20) in housing (3).

NOTE: Valves (4), (7), and (19) must be installed as shown for pump to operate correctly.

Place valve (19) in side bore of housing. Put a 4L7464 Silicone Grease on O-ring (18) and install O-ring on cover (17). Place cover on housing and install two screws (16) that hold the cover in place.

4. Put 4L7464 Silicone Grease on O-ring (15) and place O-ring on the tappet assembly (14). Place tappet assembly with O-ring in housing.
5. Put 4L7464 Silicone Grease on O-ring (13) and install O-ring on sleeve (11).
6. Place piston (12) in sleeve. Place sleeve and piston in housing.
7. Place seal (8), valve (7), washer (6), spring (5), and valve (4) in housing.
8. Put 4L7464 Silicone Grease on O-rings (9 and 10) and install O-rings in cover (2). Place cover on housing, compressing spring. Install two screws (1) that hold cover in place. Tighten capscrews.

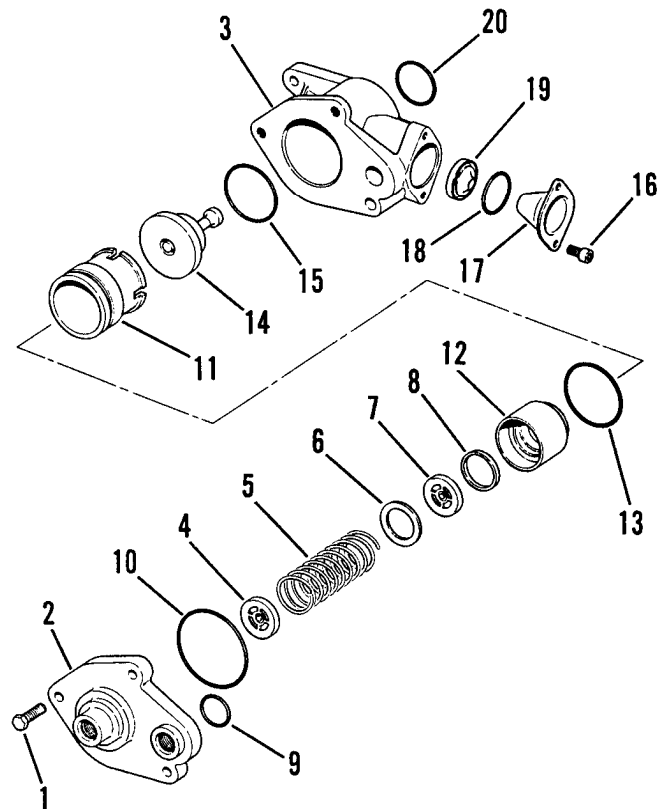

ENGINE

FUEL FILTER BASE AND FILTER

REMOVE FUEL FILTER BASE AND FILTER 1262 & 1261-11

Tools Needed		A
2P8250	Strap Wrench	1

NOTE: The fuel filter can be removed from the base with tool (A).

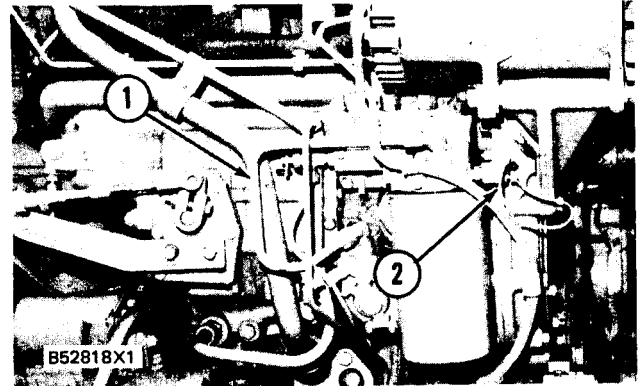

1. Remove tube assembly (1) from the fuel filter base.

2. Put identification on wires (2) and disconnect them from the sending unit.

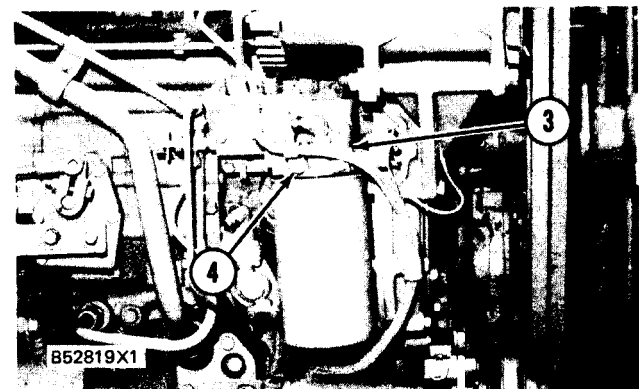

3. Remove bolts (4) and fuel filter base (3) and the filter as a unit from the engine.

INSTALL FUEL FILTER BASE AND FILTER 1262 & 1261-12

1. If necessary, make a replacement of the fuel filter gasket.



2. Put the fuel filter base (1), the filter and the gasket in position on the fuel injection pump housing. Install the bolts that hold it.

3. Connect wires (3) to the sending unit.

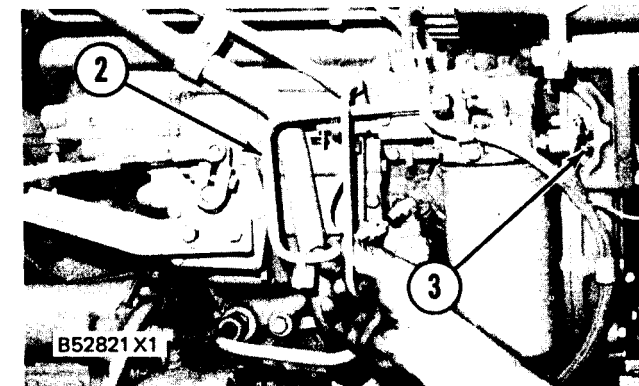

4. Install tube assembly (2) on the fuel filter base.

ENGINE

FUEL INJECTION PUMP HOUSING AND GOVERNOR

REMOVE FUEL INJECTION PUMP HOUSING AND GOVERNOR 1286-11

Tools Needed		A
8S2264	Puller Group	1
6V7031	Bolts	2
8M7145	Washer	2
8B7560	Step Plate	1

start by:

- a) remove fuel lines
- b) remove fuel filter base and filter

1. Remove nuts (2) and cover (1) from the timing gear cover.
2. Loosen bolt (3). Leave a gap of 3.2 mm (.125 in.) between the washer and the gear.
3. Use tool (A) to remove gear (4).
4. For Models 950BNS and 950BS:
 - a) Remove the nut and disconnect cable assembly (5) from the governor control lever.
 - b) Remove the bolts and disconnect bracket assembly (6) from the governor.
5. For Models 950BNSCE and 950BSCE:
 - a) Remove six screws (23), cover (24) and gasket (25).
 - b) Mark the position of lever (26) on governor shaft. Remove screw (27) and disconnect cable assembly (28) and washer (29) from lever.
 - c) Remove lever and two bushings (30).
 - d) Remove two screws (31). Remove housing (32) and seal (33) from governor.

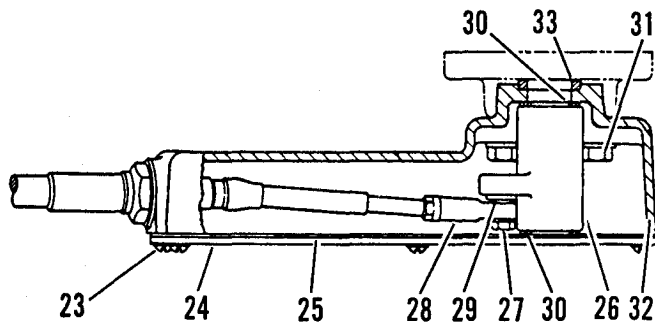
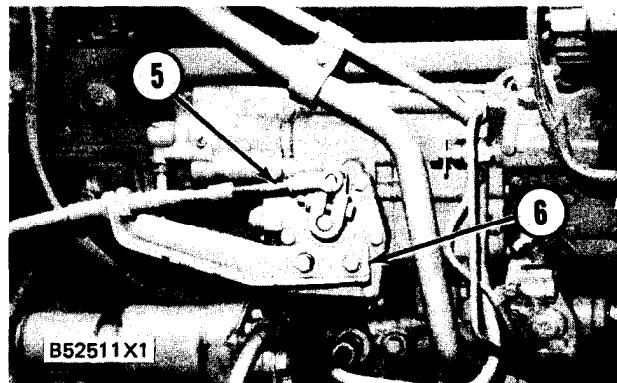
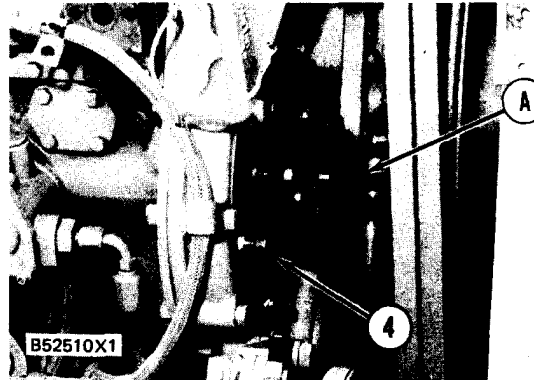
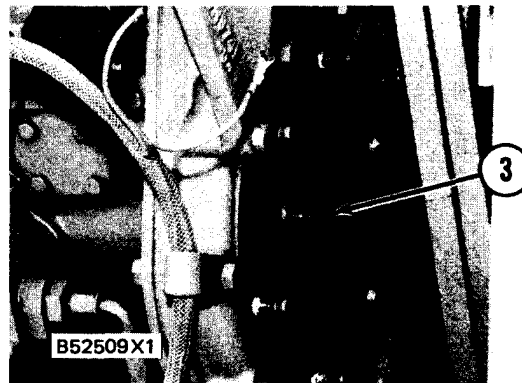
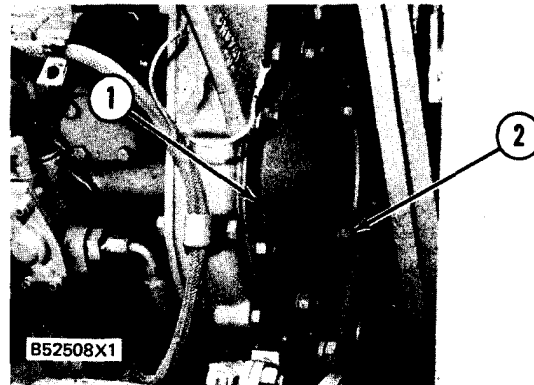

Illustration of Models 950BNSCE and 950BSCE

Illustration of Models 950BNS and 950BS

ENGINE

DISASSEMBLY AND ASSEMBLY

FUEL INJECTION PUMP HOUSING AND GOVERNOR

4. Remove the nut and disconnect cable assembly (5) from the governor control lever.
5. Remove the bolts and disconnect bracket assembly (6) from the governor.
6. Disconnect pressure line (7) at the fuel ratio control.
7. Put a mark on wires (9) and disconnect them from the fuel shutoff solenoid.
8. Disconnect wires (8) from the alternator.
9. Remove clamps (11) and tube assemblies (10) and (12) from the engine.
10. Remove the bolt and disconnect clip (16).
11. Disconnect tube assemblies (13) and (14) and hose (15).
12. Remove bolts (18) and nuts (17) that hold the fuel injection pump and governor in place.
13. Remove nut (19), the bolt (other side not shown) and heat shield (20) from the engine.

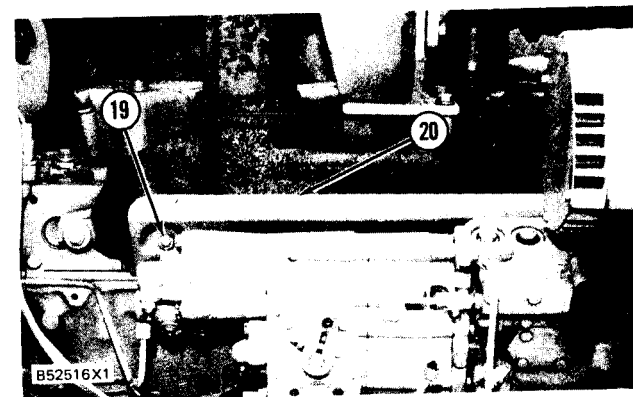
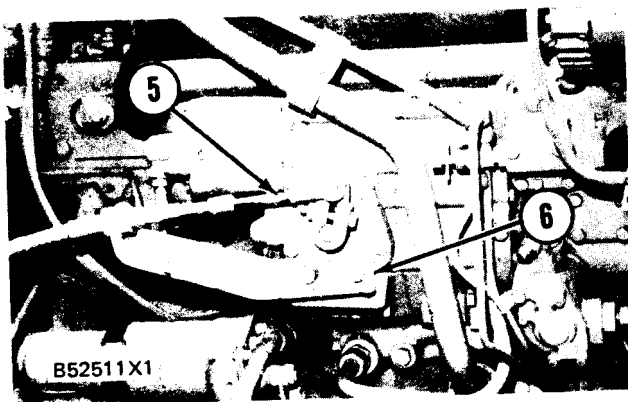
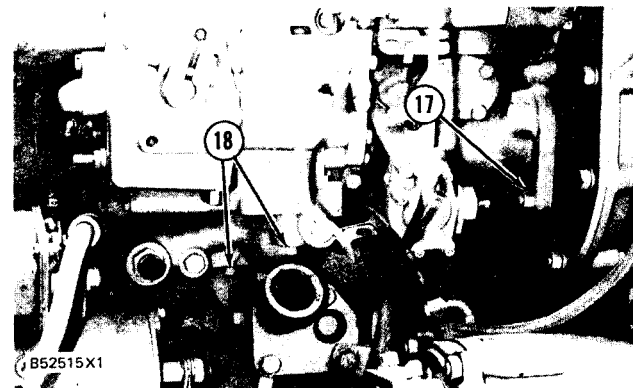
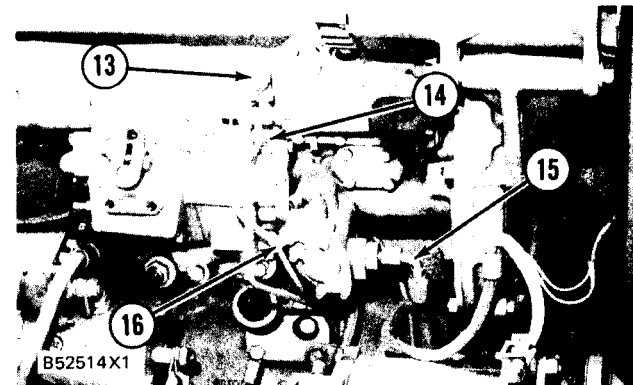
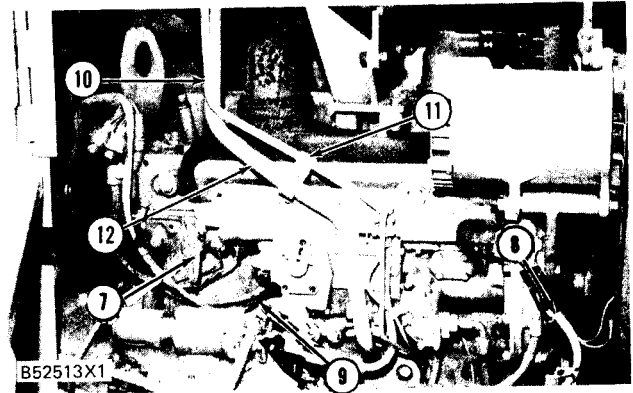

FUEL INJECTION PUMP HOUSING AND GOVERNOR

14. Fasten a strap and hoist to fuel injection pump housing and governor (21) as shown.
15. Pull drain line (22) from the clip on the engine block.
16. Remove fuel injection pump housing and governor (21). The weight of the fuel injection pump housing and governor is 26 kg (58 lb.).

INSTALL FUEL INJECTION PUMP HOUSING AND GOVERNOR 1286-12

Tools Needed		A	B
6V4186	Pin	1	
FT 1644	Adapter		1

1. Put O-ring seals (1) and (2) in position on the fuel injection pump housing and governor. Put clean oil on the O-ring seals.
2. Put the fuel injection pump housing and governor in position on the oil manifold and the timing gear plate with bolts (3) and nuts (4).
3. Put drain line (5) into position on the clip on the engine block.

CAUTION

After the fuel injection pump housing and governor are installed on the timing gear plate, be sure the rack is free to move. The O-ring seal (1) on the drive end of the fuel injection pump can hold the rack and prevent free movement of the rack. If the rack does not move freely, remove the fuel injection pump housing and governor and check the O-ring seal on the drive end of the fuel injection pump housing.

4. Install heat shield (8) between the manifold and fuel injection pump housing and governor. Tighten the bolt to a torque of $23 \pm 4 \text{ N}\cdot\text{m}$ ($17 \pm 3 \text{ lb}\cdot\text{ft.}$).
5. Connect tube assemblies (6) and hose assembly (7) as shown.
6. Install bolt (9) that holds the clip.

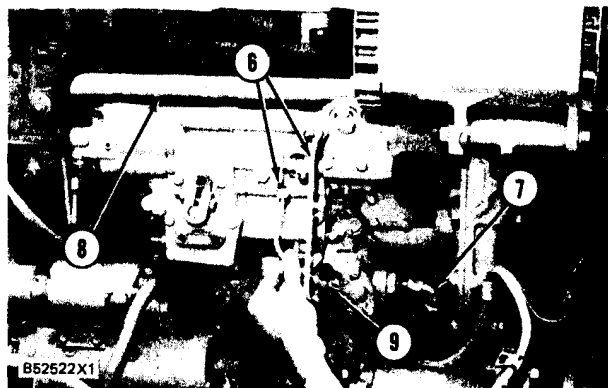
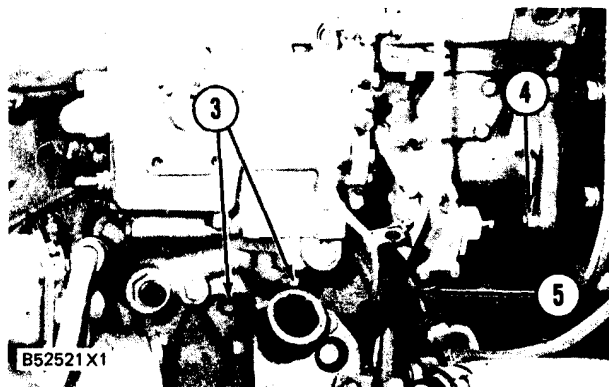
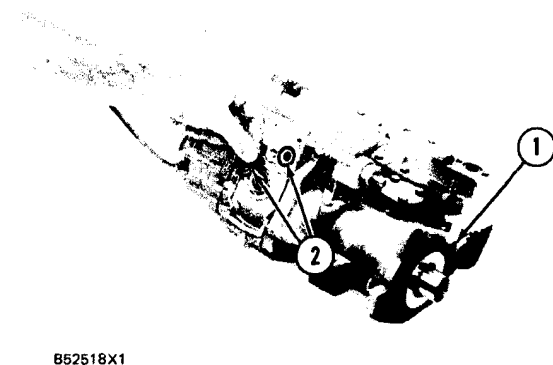
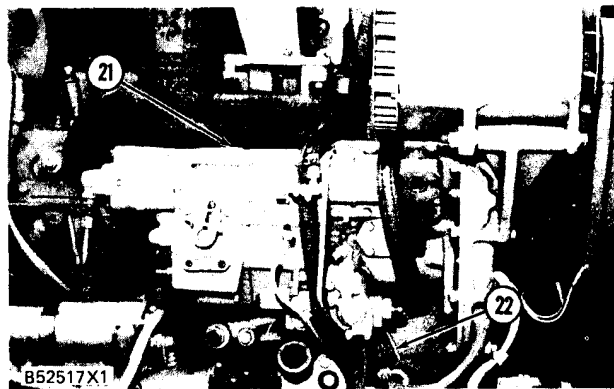

ENGINE

DISASSEMBLY AND ASSEMBLY

FUEL INJECTION PUMP HOUSING AND GOVERNOR

7. Install tube assemblies (10) and (11) to the engine and the clip that holds them together.
8. Connect wire assemblies (12) to the alternator.
9. Connect wires (14) to the fuel shutoff solenoid.
10. Connect pressure line (13) to the fuel ratio control.
11. For Models 950BNS and 950BS:
 - a) Connect bracket (16) to the governor.
 - b) Connect cable assembly (15) to the governor control lever.
12. For Models 950BNSCE and 950BSCE:
 - a) Install housing (26), seal (27), and two screws (28).
 - b) Turn governor shaft clockwise to off position. Install lever (29) and two bushings (30), with lever approximately 350 forward of vertical.
 - c) Connect cable assembly (31) using washer (32) and screw (33).
 - d) Install gasket (34), cover (35), and six screws (36).

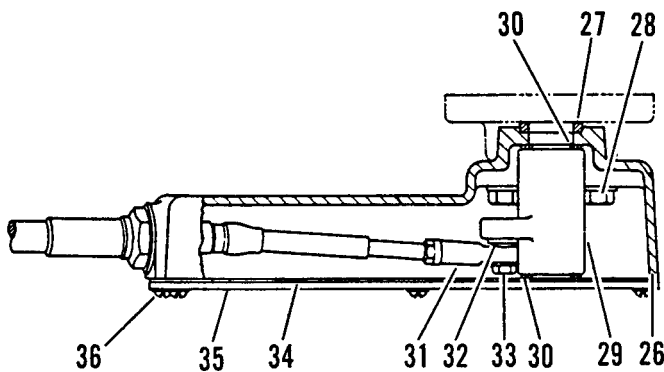
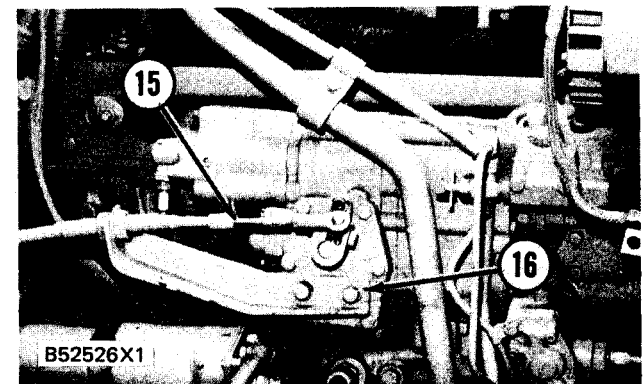
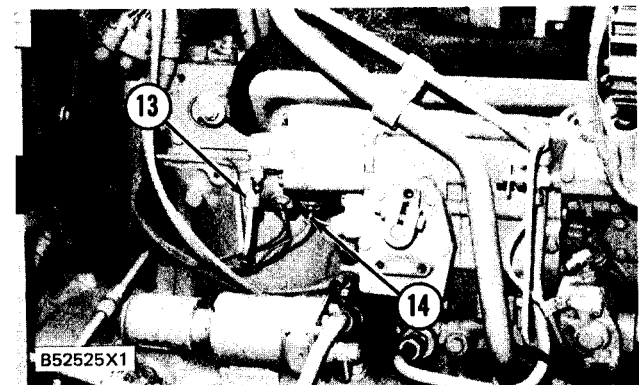
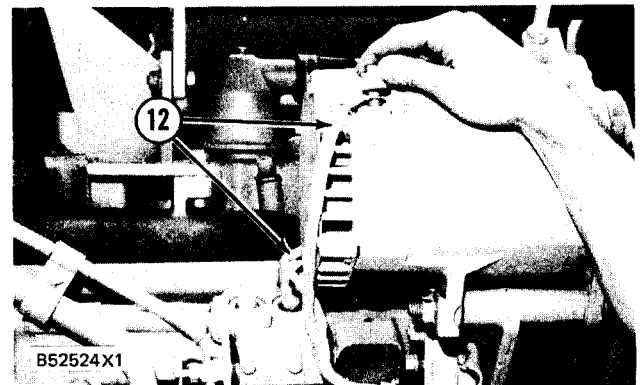
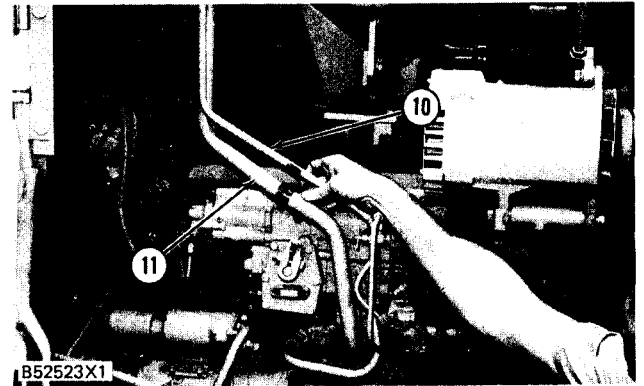

Illustration of 950BNSCE and 950BSCE

Illustration of Models 950BNS and 950BS

FUEL INJECTION PUMP HOUSING AND GOVERNOR

13. Use the following procedure to put the No. 1 piston at top center on the compression stroke. No. 1 piston at top center (TC) on the compression stroke is the starting point for all timing procedures.
- Loosen hose clamps (18), bolt (17) and remove the breather from the valve cover.
 - Remove the plug from the flywheel housing.
 - Turn the crankshaft clockwise (as seen from the front of the engine) until a 3/8"-16 NC bolt (19) at least 2.5 in. long can be installed in the flywheel through the hole in the flywheel housing. Do not turn the crankshaft counterclockwise.

NOTE: The rocker arms for No. 1 piston can be seen through the breather hole in the valve cover.

- Check to see if both rocker arms for the No. 1 piston can be moved backward and forward by hand.

NOTE: The No. 1 piston is at top center on the compression stroke when bolt (19) can be put in the flywheel through the hole in the flywheel housing, and both rocker arms for the No. 1 piston can be moved backward and forward by hand.

- If both rocker arms can not be moved by hand, the No. 1 piston is not at top center on the compression stroke. Remove bolt (19) from the flywheel and turn the crankshaft clockwise one full turn (360°). Install the timing bolt in the flywheel again. Check to see if both rocker arms for the No. 1 piston can be moved backward and forward by hand.

14. Remove the bolts and cover (20) from the fuel pump housing.

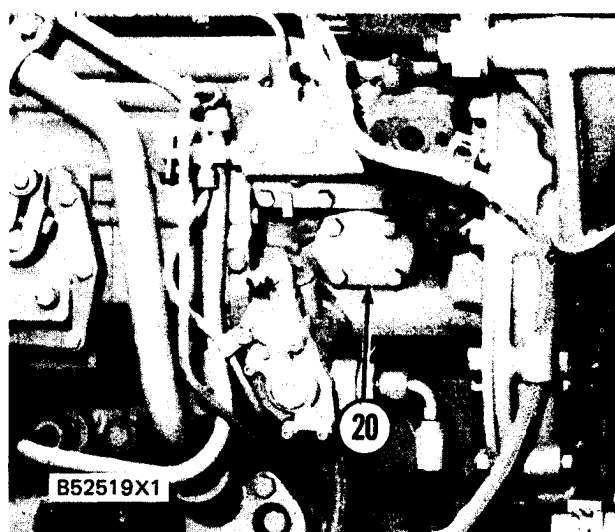
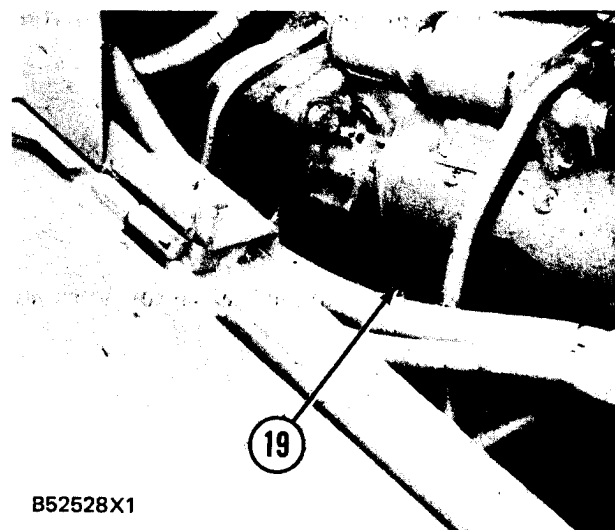
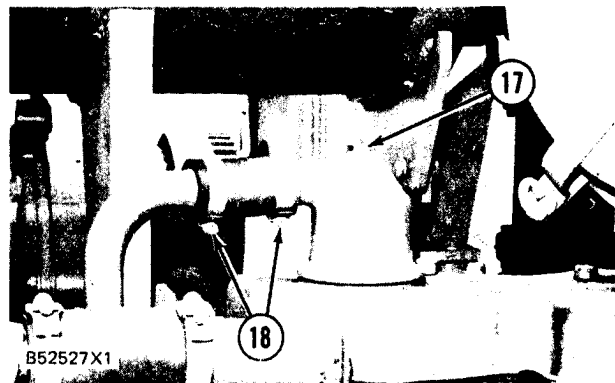

FUEL INJECTION PUMP HOUSING AND GOVERNOR

15. Install bolt (21) on the fuel injection pump camshaft without the washer.
16. Install tooling (A) in the fuel injection pump housing. Push on tool (A) and turn the fuel injection pump camshaft. When tooling (A) slides down into the groove (slot) in the fuel injection pump camshaft, the fuel injection pump is in the No. 1 piston top center position.
17. With tool (A) still in position remove the bolt from fuel injection pump camshaft.
18. Install the washer and the bolt in the fuel injection pump camshaft. Make sure the washer is installed with the large outside diameter toward the bolt head. Tighten the bolt finger tight only.
19. Install tool (B) on the gear.
20. Use two torque wrenches to put a clockwise force of 68 N·m (50 lb.ft.) on tool (B) to remove the gear clearance (backlash) while the bolt is tightened to a torque of 270 ± 25 N·m (199 ± 18 lb. ft.).
21. Check the timing as follows to make sure it is correct:
 - a) Remove the timing pin from the pump camshaft and the bolt from the flywheel.
 - b) Turn the crankshaft clockwise (as seen from the front of the engine) approximately $\frac{1}{2}$ turn. Install the timing pin again.
 - c) While the crankshaft is turned clockwise (as seen from the front of the engine), push on the timing pin (A) until it slides into the groove (slot) in the pump camshaft.
 - d) Install the bolt in the flywheel.

NOTE: The timing is correct when the bolt is installed in the flywheel and the timing pin (A) is installed in the groove (slot) in the pump camshaft.

22. Remove the bolt from the flywheel.

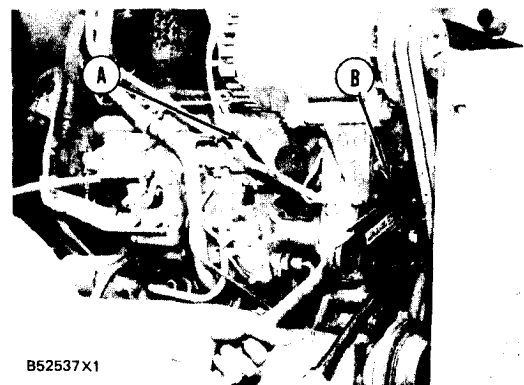
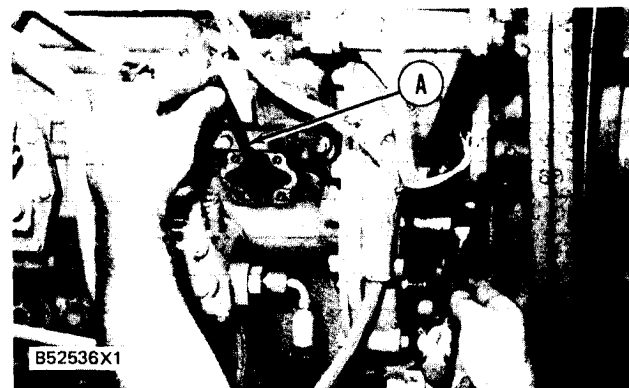
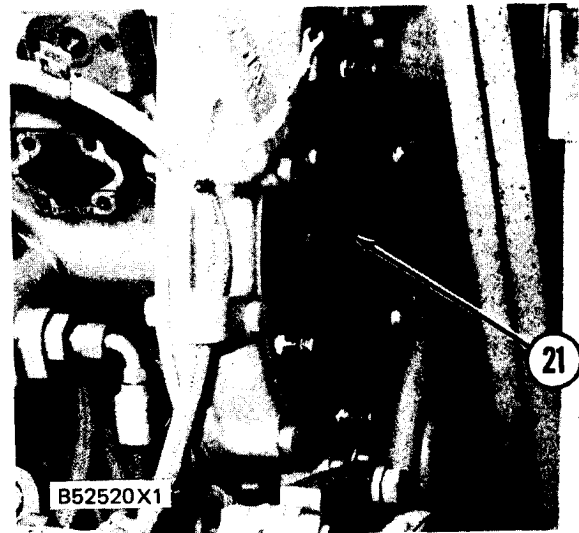

FUEL INJECTION PUMP HOUSING

23. Install covers (20) and (22) on the fuel injection pump housing and the timing gear cover. Tighten nuts (23) to a torque of 27 ± 7 N·m (20 ± 5 lb. ft.).

24. Put breather (25) in position on the valve cover. Tighten the hose clamps. Tighten bolt (24) to a torque of 14 ± 3 N·m (10 ± 2 lb. ft.).
end by:

- a) install fuel lines
- b) install fuel filter base and filter

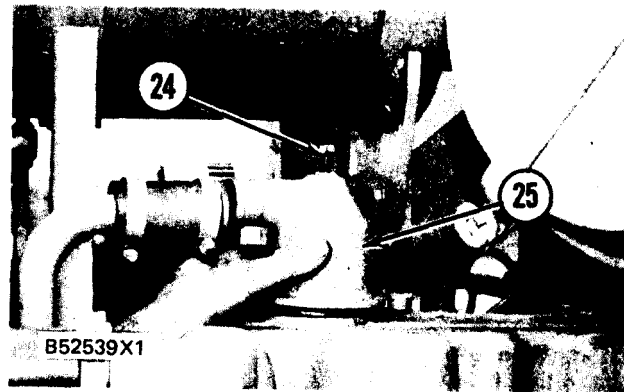
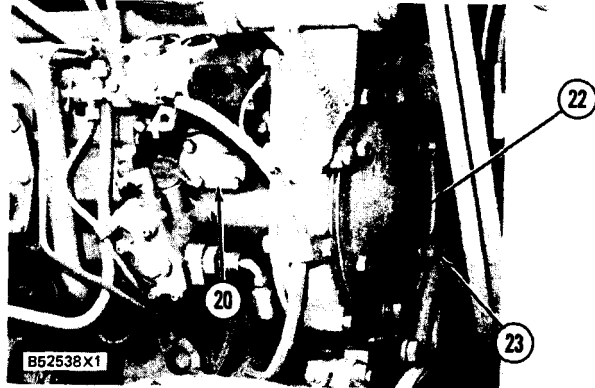

FUEL INJECTION PUMP HOUSING

DISASSEMBLE FUEL INJECTION PUMP HOUSING 1253-15

Tools Needed		A	B	C	D	E
1P1859	Snap Ring Pliers	1				
6V4186	Timing Pin		1			
1P510	Driver Group			1		
8S4613	Wrench				1	
8S2244	Extractor					1

start by:

- a) remove governor from fuel injection pump housing
1. Remove cover (1).
2. Install tooling (B). Engage the timing pin in the center groove of the fuel rack. Move the fuel rack in the direction of the arrow to find the center groove.
3. Install tooling (D) and remove bushing (2).

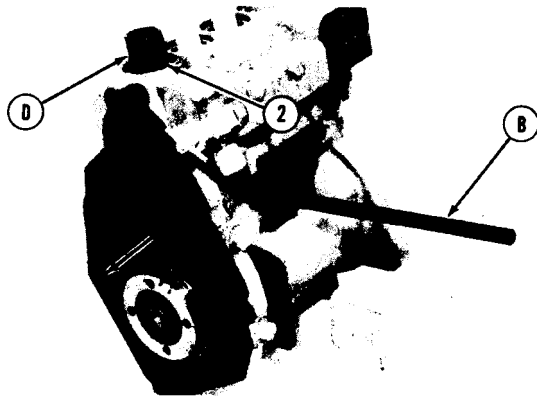

4. Install tooling(E) and remove the fuel injection pump.
5. Remove spacer (3).
6. Remove the remainder of the fuel injection pumps and spacers with Steps 2-5 done again for each fuel injection pump.

NOTE: Do not mix components from fuel injection pump assemblies.

7. Remove cover (4).

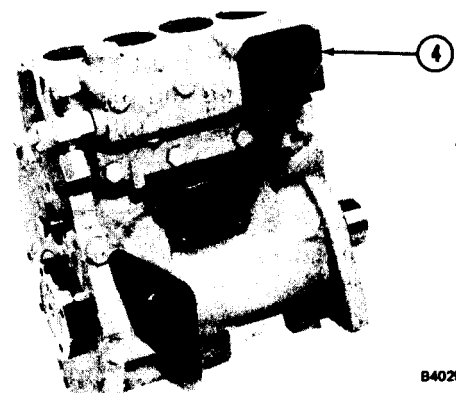
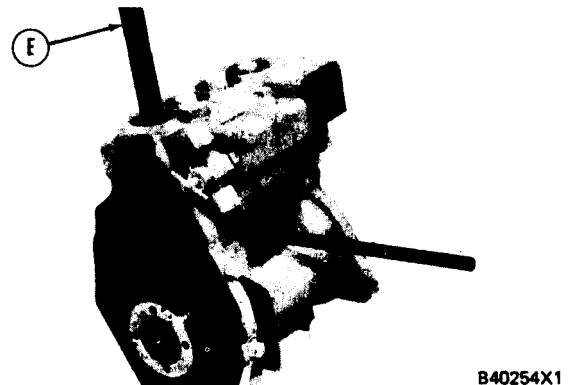
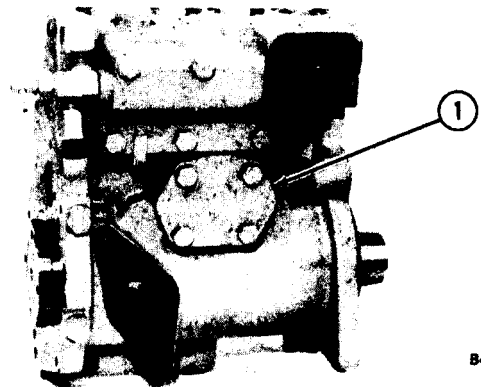
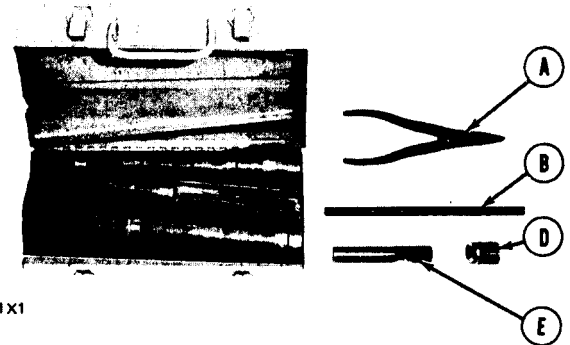
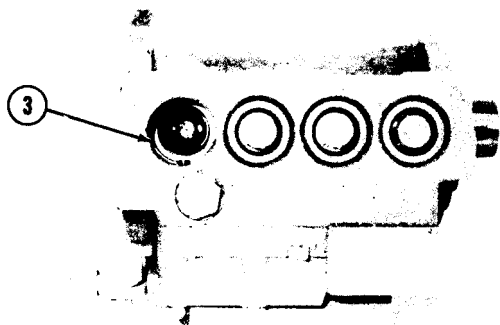

FUEL INJECTION PUMP HOUSING

8. Remove fuel rack (5).

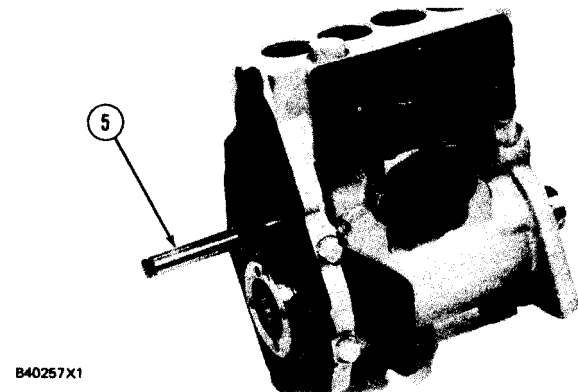

9. Use a bar magnet to remove lifter assembly (6).

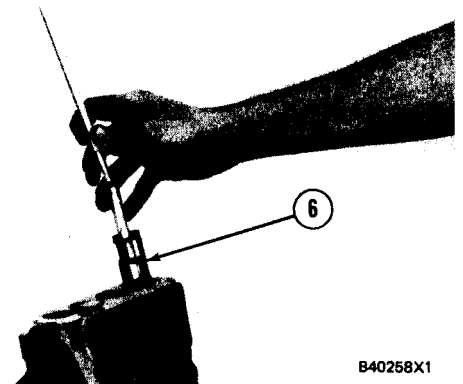

10. Use tooling (A) to remove snap ring (7).

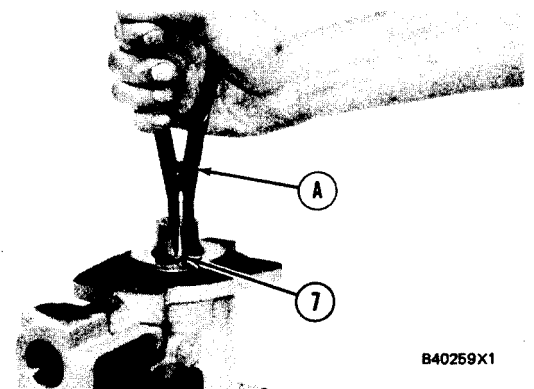

11. Use a plastic hammer to make camshaft (8) move out of washer (9).

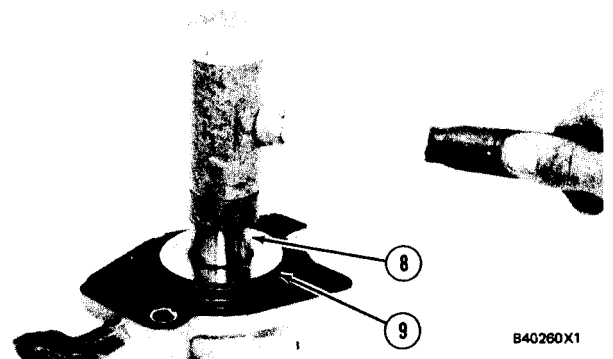

NOTE: Do not let the camshaft fall because the machined surfaces will be scratched.

FUEL INJECTION PUMP HOUSING

12. Remove camshaft (8).

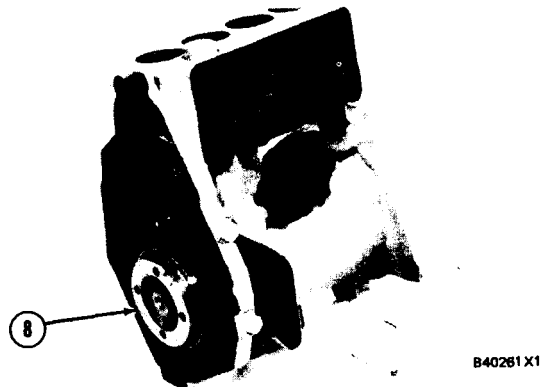

13. Remove rack rear bearing (10) and camshaft rear bearing (11).

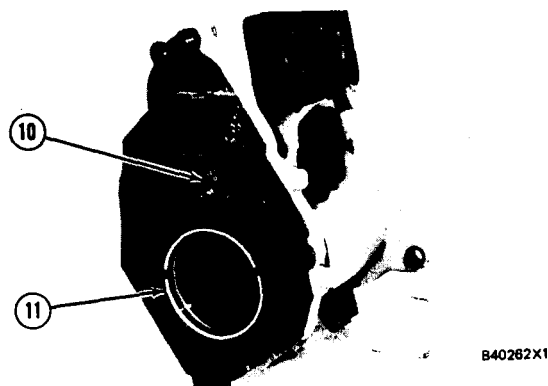

14. Install location plate from tooling (B). Align the bore in the plate with the O-ring seal counterbore in the fuel injection pump housing. Make a mark for alignment.

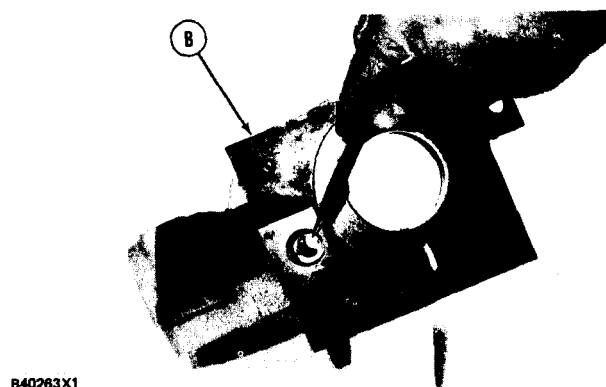

15. Remove tooling (B).

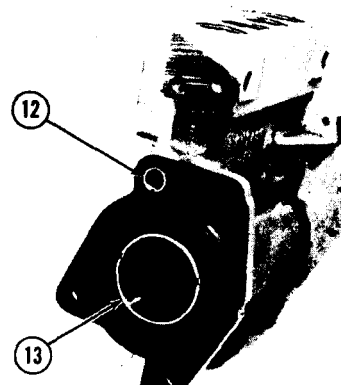

16. Remove the rack bearing (12) and camshaft bearing (13).

FUEL INJECTION PUMP HOUSING

ASSEMBLE FUEL INJECTION PUMP HOUSING

1253-16

Tools Needed	A	B	C	D	E	F	G	H
1P510 Driver Group	1							
6V4818 Driver		1*						
6V2016 Locator Plate		1*						
6V4186 Timing Pin		1						
FT1443 Sleeve			1					
1P1859 Snap Ring Pliers				1				
8S2244 Extractor					1			
8S4613 Wrench						1		
9S228 Rack Position Tool Group								1
3S3270 1 3/4" Contact Tip								1
C-Clamp								1

*1 Part of 6V4095 Tool Group.

NOTE: Be sure all oil passages are clear and put clean oil on all parts before assembly.

1. Use tool (A) to install the camshaft rear (governor end) bearing. Install the bearing with the junction (joint) toward the top of the fuel injection pump housing. Install the bearing so it is 1.00 ± 0.25 mm (.039 \pm .010 in.) below the surface of the housing.
2. Use tooling (A) to install the fuel rack rear (governor end) bearing. Install the bearing so it is 7.16 ± 0.13 mm (.282 \pm .005 in.) below the surface of the housing.
3. Install the locator plate from tooling (B) on the drive end of the fuel injection pump housing to install the bearing for the fuel rack. Use clean grease to hold the new fuel rack bearing on the driver from tooling (C). Install the driver and bearing in the plate with the groove in the driver in alignment with the pin in the plate and use a hammer to push the bearing into position. The bearing will be installed to the correct depth when the shoulder of the driver is against the plate.

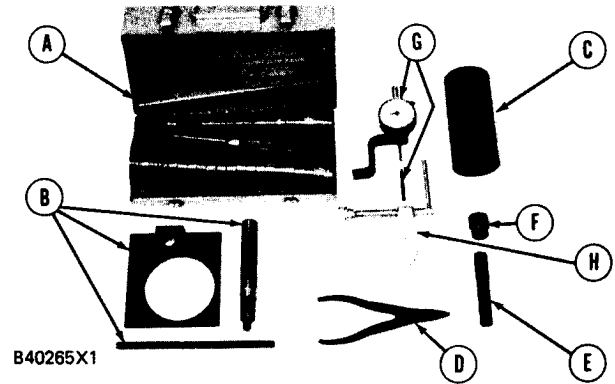

B40265X1

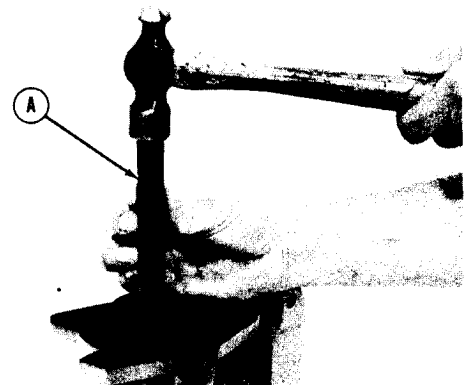

B40266X1

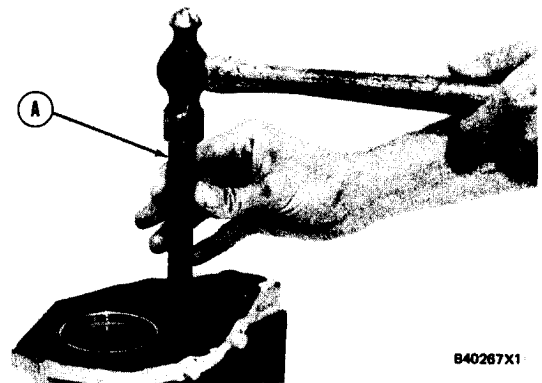

B40267X1

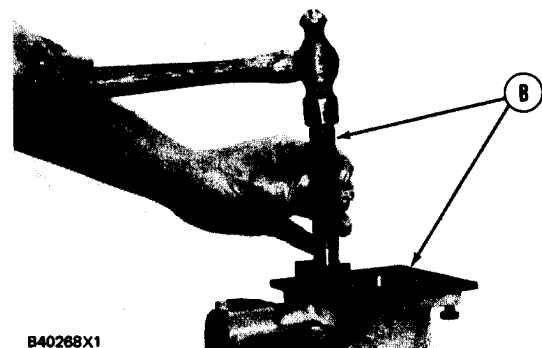

B40268X1

FUEL INJECTION PUMP HOUSING

4. Remove tooling (B) from the fuel injection pump housing. The rack bearing must be installed so it is 0.25 ± 0.25 mm (0.010 ± 0.010 in.) below the surface of the housing.

5. Install the fuel injection pump camshaft (1) in the fuel injection pump housing.

6. Put the fuel injection pump housing on end and put a block under the camshaft.

7. Put washer (2) over the end of the camshaft and use tooling (A) and (C) to push washer (2) against its seat on the camshaft. The camshaft must have 0.285 ± 0.235 mm (0.0112 ± 0.0093 in.) end play when the washer is pushed against cam shoulder.

8. Use tool (D) to install snap ring (3) in the groove in the camshaft.

9. Install four lifter assemblies (4) in the fuel injection pump housing with the groove in the lifter in alignment with the pin in the housing.

NOTE: The four lifters are all the same and can be mixed.

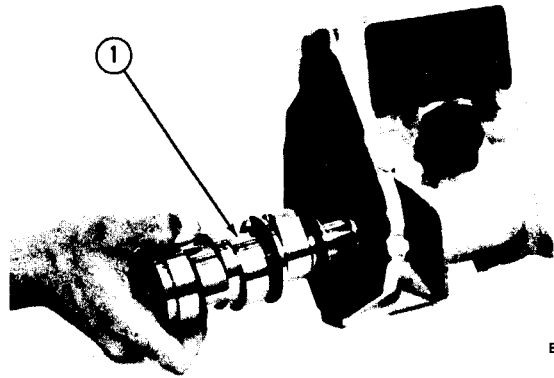

B40269X1

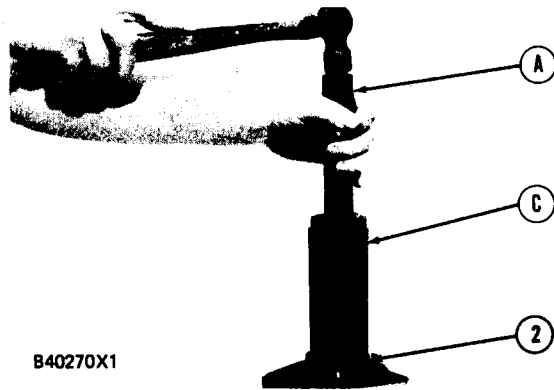

B40270X1

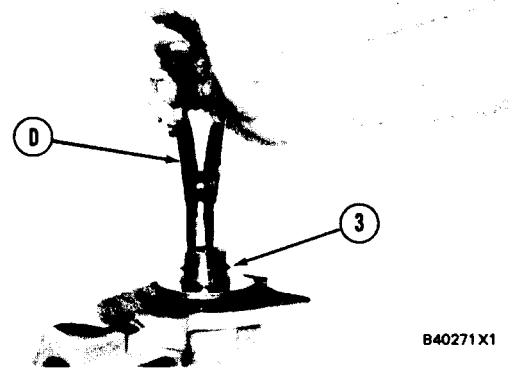

B40271X1

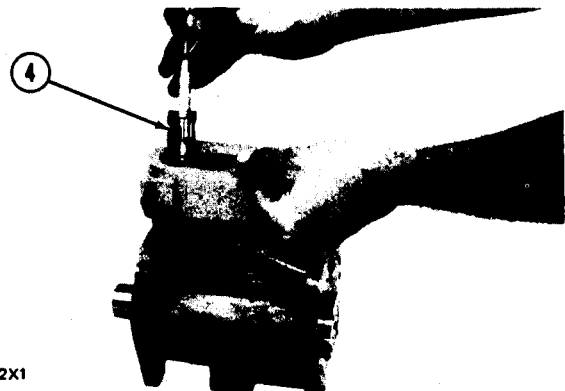

B40272X1

FUEL INJECTION PUMP HOUSING

10. Install fuel rack (5) in the fuel injection pump housing with the groove in the end of fuel rack in alignment with the ear (tab) of the rack bearing at the drive end of the fuel injection pump housing.

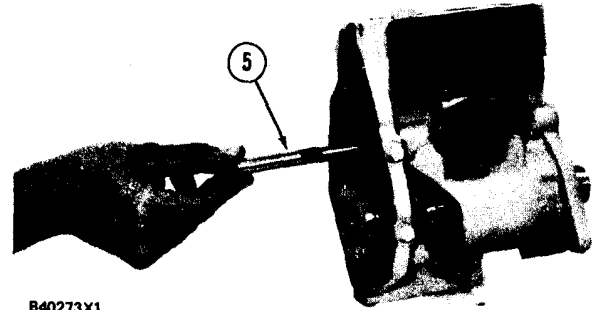

11. Install timing pin from tooling (B). Engage the timing pin in the center groove of the fuel rack. Move the fuel rack in the direction of the arrow to locate the center groove.

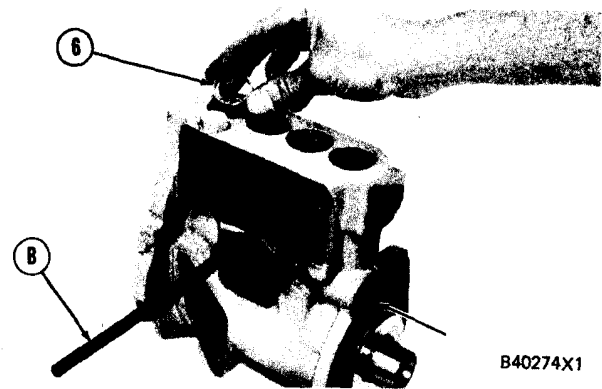

12. Install spacer (6).

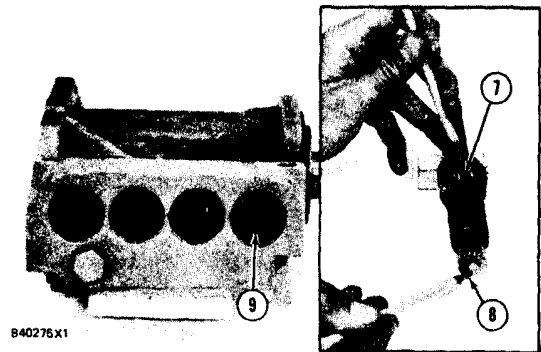

13. Put the (slot) groove (8) in the gear segment 180° away from the groove (7) in the barrel. When the fuel injection pump is installed, groove (7) must engage the dowel (9).

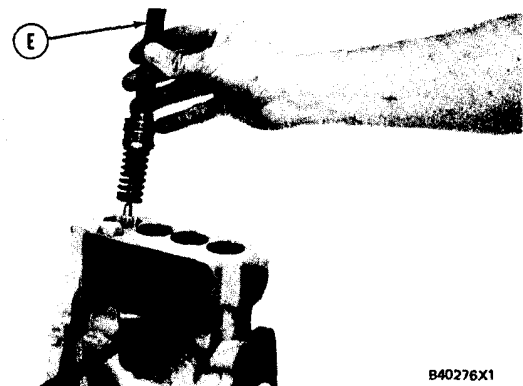

14. Use tool (E) to install the fuel injection pump. Installation is made easier by rotation of the cam lobe away from the lifter assembly.

FUEL INJECTION PUMP HOUSING

15. Install O-ring seal (10).

16. Install bushing (11). Tighten bushing (11) by hand until the bushing is even with the top of the housing. If installation of the bushing can not be made this far by hand, remove it. Remove the pump, put the parts in alignment again and install the bushing again.

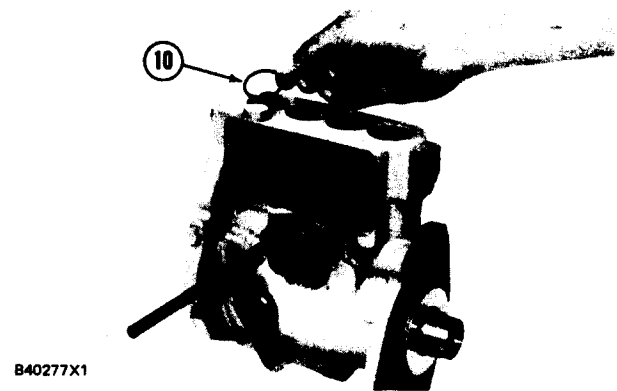

17. Use tool (F) and a torque wrench to tighten the bushing to a torque of 190 ± 14 N·m (140 ± 10 lb. ft.).



18. Remove tooling (B).

19. Install tooling (G) and (H) to measure total rack travel. Correct rack travel is 15.7 mm (.618 in.). A smaller measurement is an indication of wrong fuel injection pump installation.

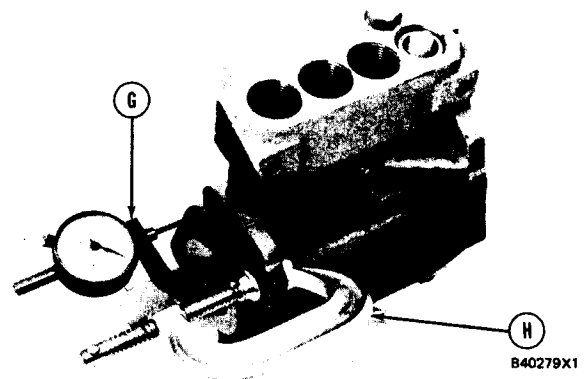

20. Complete the installation of the remainder of fuel injection pumps as given in Steps 11-19.

21. Install cover and gasket (12).
end by:

- a) install governor on fuel injection pump housing

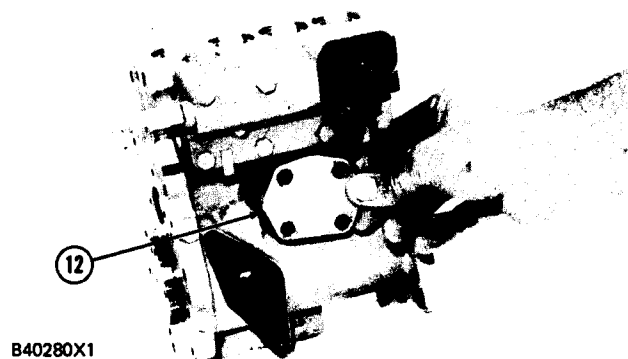

GOVERNOR

DISASSEMBLE GOVERNOR

1284-15

Tools Needed		A	B	C
1P510	Driver Group	1		
1P1855	Snap Ring Pliers*		1	
6V2163	Clamp Assembly Spring Compressor*			1

*Part of 6V4095 Tool Group.

start by:

- a) remove fuel injection pump housing and governor
- b) remove fuel transfer pump
- c) **on models 950BSCE and 950BNSCE remove tachometer drive.**

NOTE: If it is desired to remove only the governor so the fuel injection pump housing can be disassembled, do only Steps 1, 2, 15, 21, 25, 26, 27, 28, 31, 33, 34 and 37.

1. Remove bolts (1) and remove fuel ratio control (2). Remove the fuel shutoff solenoid.
2. Remove six bolts (3), two top bolts (4), housing (5) and the gasket.
3. Remove governor spring (6), the two wave washers, one flatwasher and seat from the guide in the housing.

NOTE: For models 950BNSCE and 950BSCE, governor lever has already been removed. Go to step 5.

4. Make a mark of the position of lever (7) on shaft (8). Loosen bolt (10). Use a chisel or screwdriver to cause expansion of lever (7) so it can be removed from shaft (8).

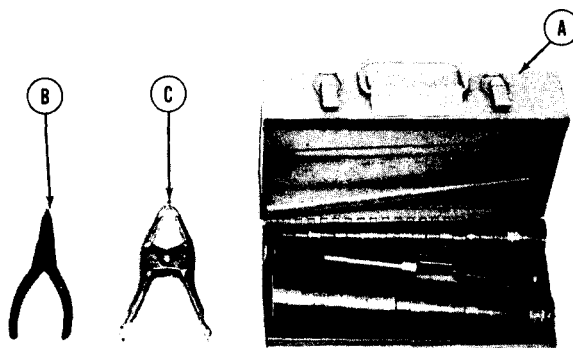

B40281X1

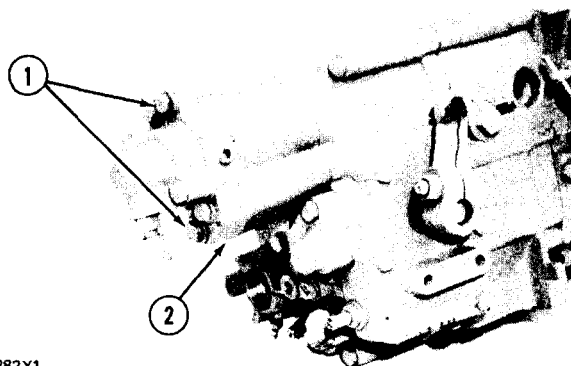

B40282X1

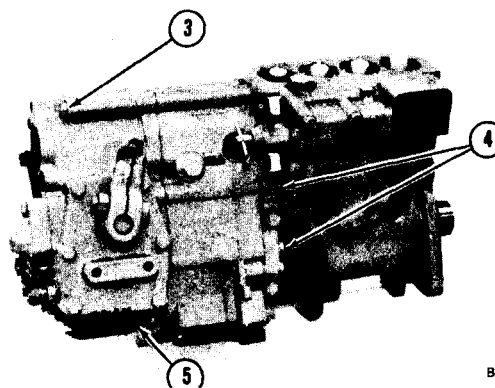

B40283X1

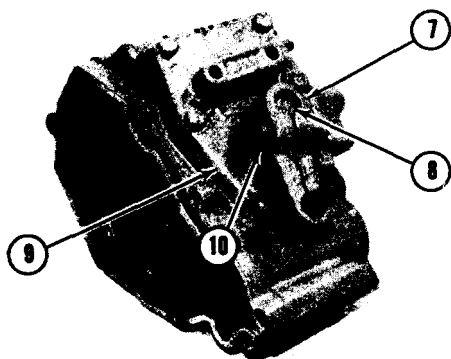

B40285X1

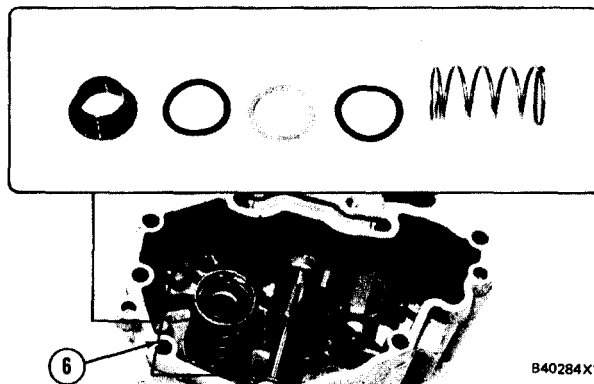

B40284X1

GOVERNOR

5. Remove cover assembly (9).

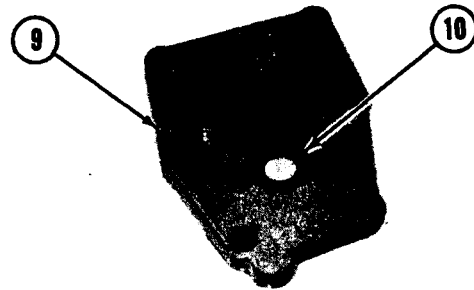

B40286X1

6. Use tooling (A) to remove seal (10) from cover (9).

7. Remove low idle adjustment screw (12) and spring (11) from the housing.

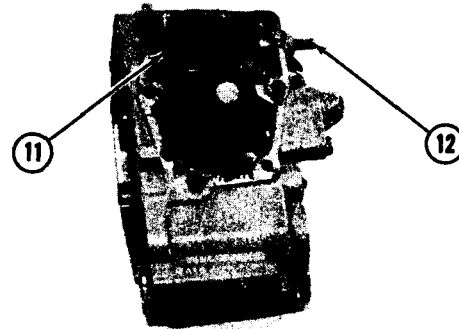

B40287X1

8. Remove shaft assembly (14), lever (13) and lever (15) from the housing.

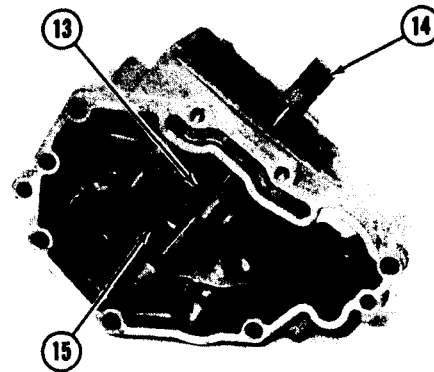

B40288X1

9. Remove two snap rings from pins (17) and remove pins (17). Remove plates (16) and stop (18) from the shaft assembly.

B6287X2

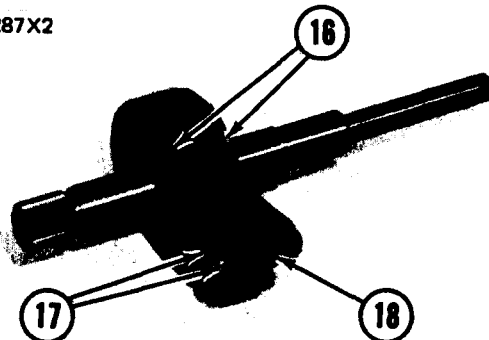

10. Remove pin (20), pin (19) and spring (21) from the shaft assembly.

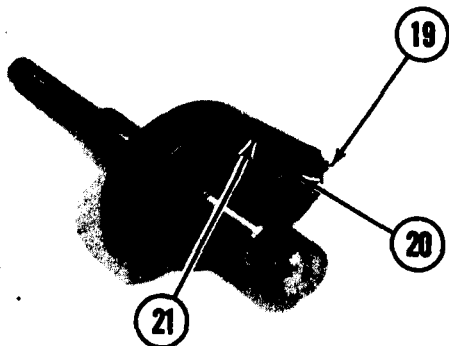

B6289X2

GOVERNOR

11. Remove shaft (22) and lever (23) from the housing.

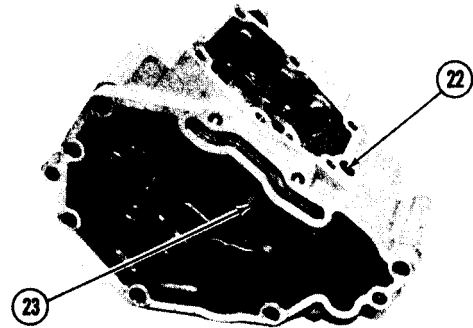

B40289X1

12. Remove check valve (24) if a replacement is necessary.

CAUTION

Remove check valve (24) only if a replacement is necessary because the check valve will be damaged during removal.

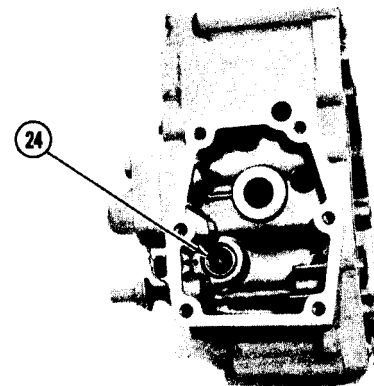

B40290X1

13. Remove contact (25) and body (26) for the governor dashpot adjustment screw from the housing. Remove bolts (27), cover (28) and the gasket from the housing.

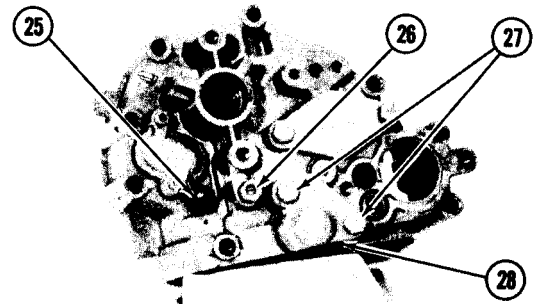

B40291X1

14. Remove seal (29) and adjustment screw (30) for high idle.

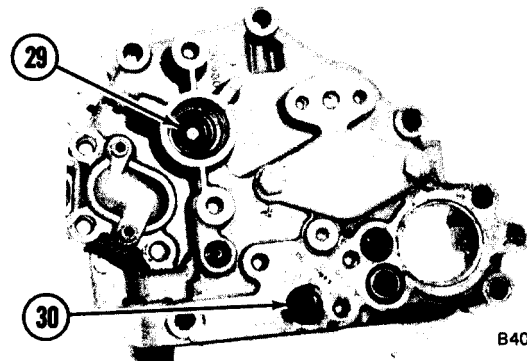

B40292X1

15. Remove two bolts (31), housing (32) and the gasket from the fuel injection pump housing.

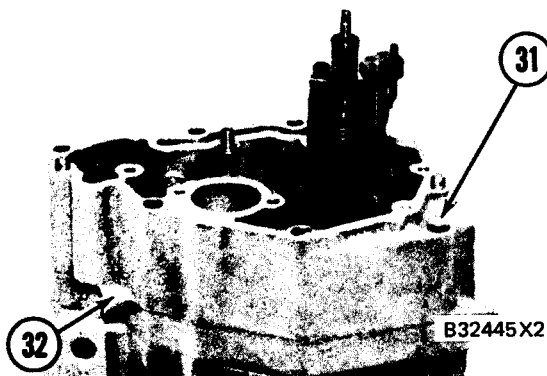

B32445X2

GOVERNOR

16. Remove bolts (33) and torque control group (34).

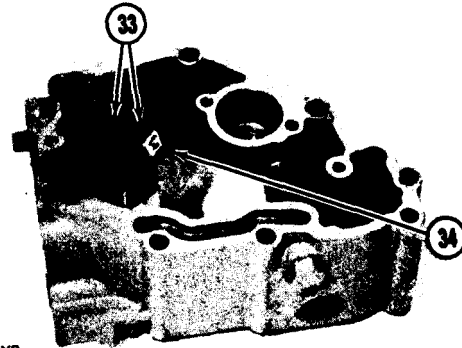

B33621 X2

17. Disassemble the torque control group and inspect the spacer, spring and insulator for damage or wear.

18. Remove bolts (36) and block (35) for the full load step from the housing.

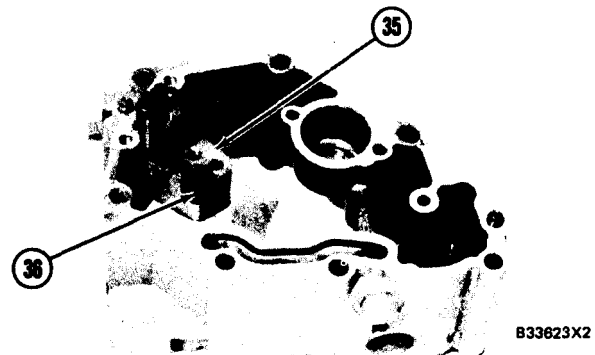

B33623 X2

19. Remove the bolt that holds collar (37) to bolt (39). Remove collar (37) and spring (38) from bolt (39). Remove bolt (39) from the block.

20. Remove the stop screw from collar (37) if a replacement is necessary.

21. Remove bolts (41) and governor servo (40) from the fuel injection pump.

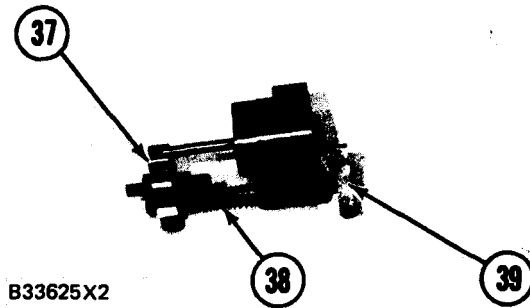

B33625 X2

22. Remove lockring (46), seat (45), spring (broken link spring) (44) and sleeve (43) from valve (42). Remove the other lockring (46) from the groove in the center of valve (42).

NOTE: The groove in the bottom of valve (42) must be in alignment with the servo body to permit removal from the fuel rack.

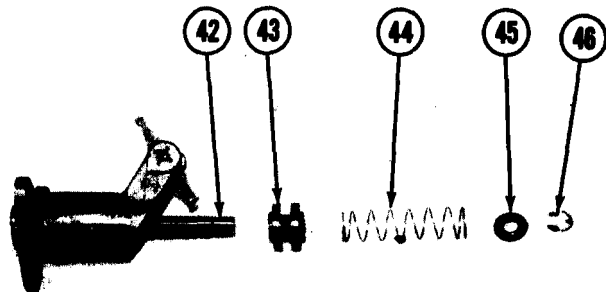

B8303 X3

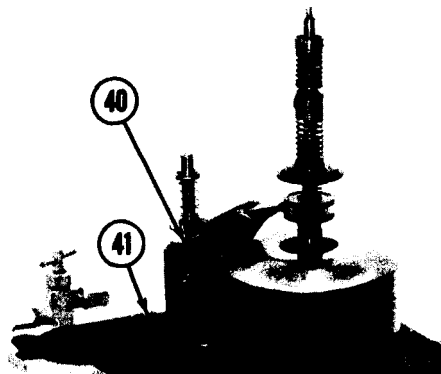

B40293 X1

GOVERNOR

23. Remove valve (42), sleeve (47) and piston (49) from the governor servo. Remove the O-ring seal from sleeve (47).

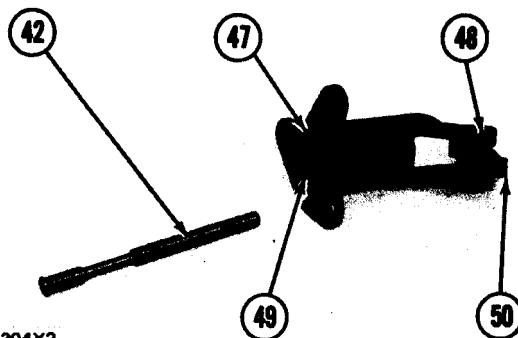

B6304X2

24. Remove pin (48) and lever (50) from the governor servo.

25. Use tool (C) to hold spring (52) in compression so ring (51) can be removed. Spring (52) is used to put a preload on the thrust bearing for the camshaft in the fuel injection pump housing.

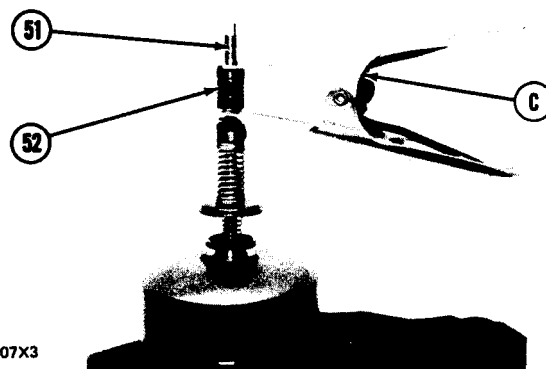

B6307X3

26. Remove ring (51) then remove tool (C).

27. Remove bearing (53), sleeves (54) and spring (52) from the governor shaft.

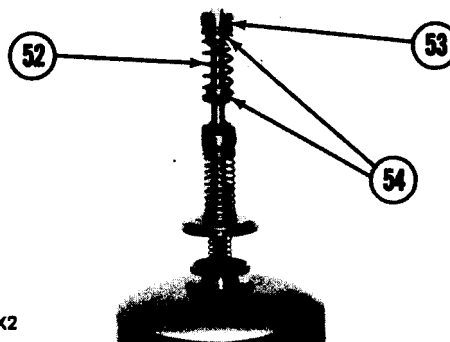

B6308X2

28. Remove ring (55) and dashpot assembly (56) from the governor shaft.

29. Use tool (B) to remove snap ring (62) from seat (59). Remove ring (61) and spool (60) from seat (59).

30. Remove seat (59) from spring (58) and remove spring (58) from seat (57).

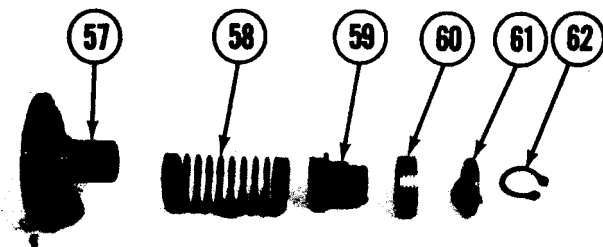

B6310X3

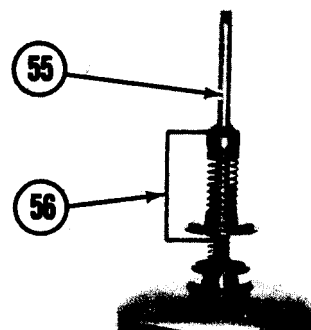

B6309X2

GOVERNOR

31. Remove spring (overfueling spring) (63) and riser (64) from the governor shaft.

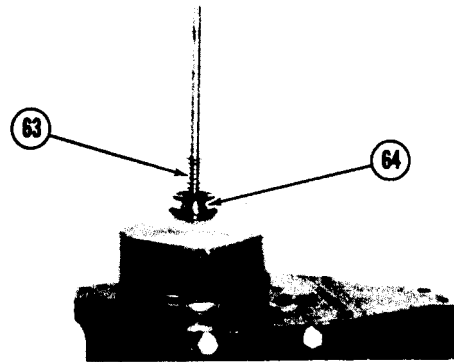

B6311X2

32. Remove ring (65), races (66) and bearing (67) from the riser.

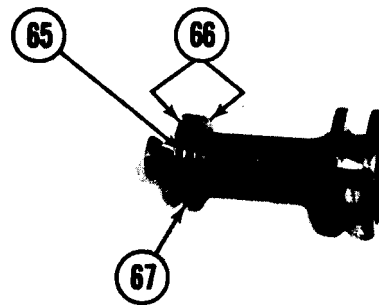

B6312X2

33. Use a screwdriver to remove shield (68) as shown.

NOTE: Make a replacement of shield (68) any time it is removed.

34. Remove bolts (69) and carrier (70) for the governor flyweights.

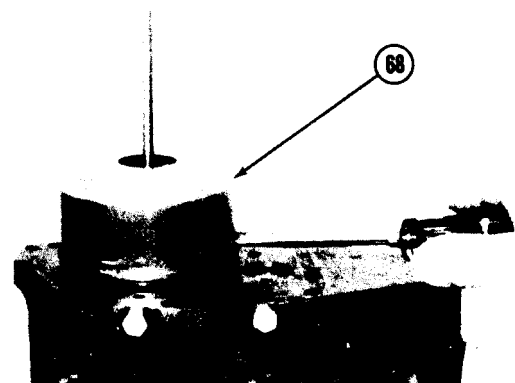

B6313X2

35. Remove dowels (71) and flyweights (73) from the carrier.

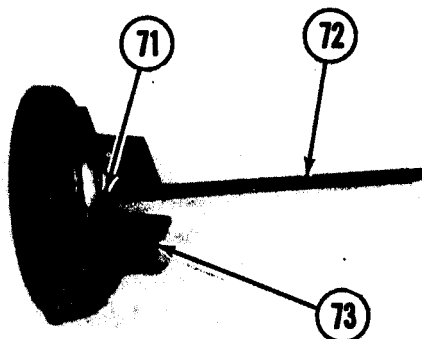

B6315X2

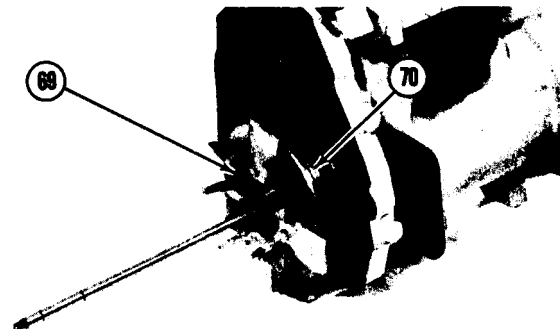

B40294X1

GOVERNOR

37. Remove races (74) and bearing (75) from the camshaft in the fuel injection pump housing.

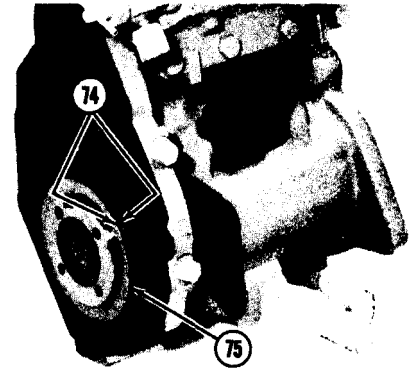

B40295X1

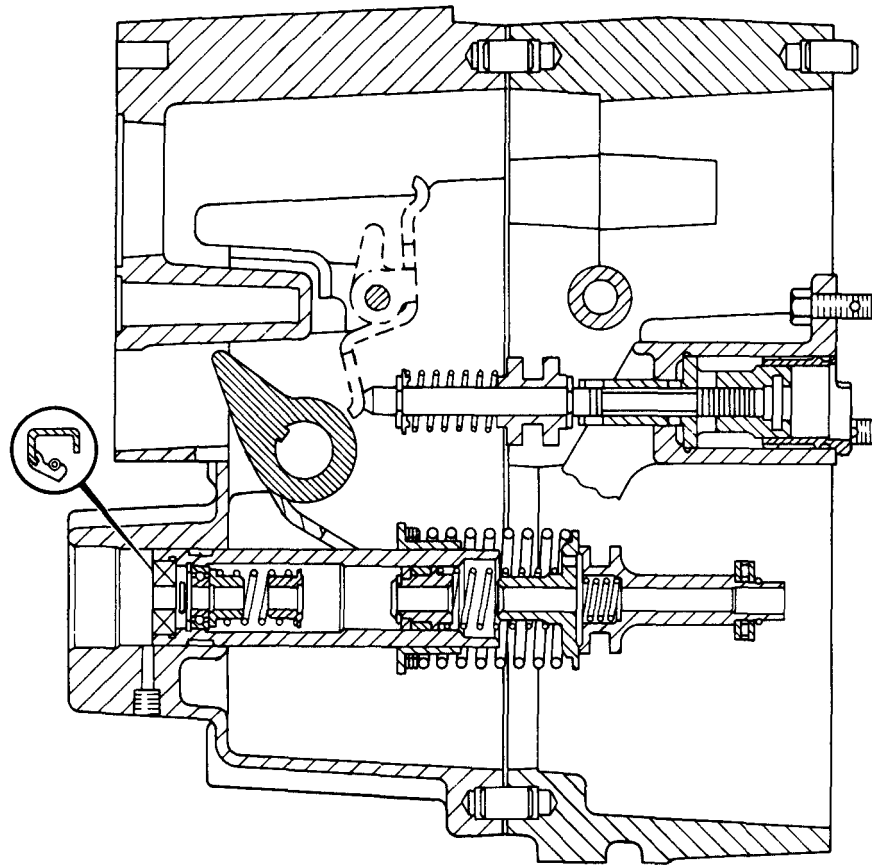

B40324X1

GOVERNOR

ASSEMBLE GOVERNOR

1264-16

	Tools Needed	A	B	C	D
6V2054	Shield Driver	1			
1P1855	Snap Ring Pliers		1		
6V2163	Clamp Assembly-Spring Compressor			1	
1P510	Driver Group				1

NOTE: If the governor was removed only to permit repair of the fuel injection pump housing, do only Steps 1, 4, 5, 7, 9, 10, 11, 16, 22, 37, 39, and 40.

NOTE: Put clean oil on all parts before assembly. Be sure all oil passages are clear.

1. Install one race (1), bearing (2) and the other race (1) on the camshaft in the fuel injection pump housing.
2. Put flyweights (3) in position on carrier (4) and install the dowels to hold the flyweights in place. The flyweights must move freely on the dowels and have 0.010 to 0.23 mm (0.0004 to 0.009 in.) end play.
3. Install dowel (5) in governor shaft (6) and install the governor shaft in the carrier as shown.
4. Put the carrier in position on the camshaft and install the bolts that hold the carrier in place.

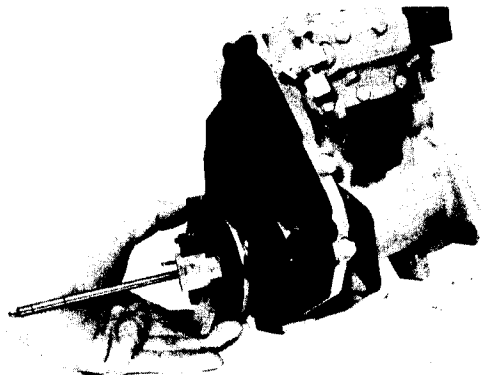
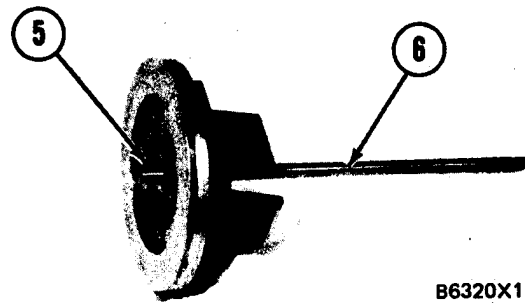
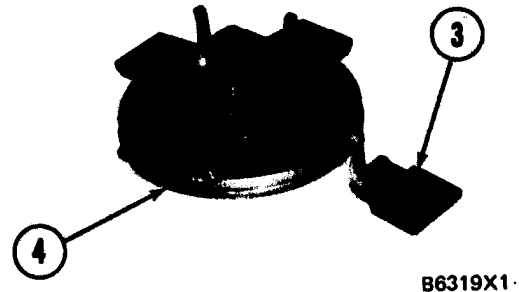
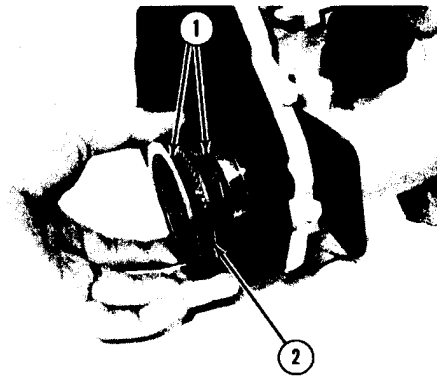
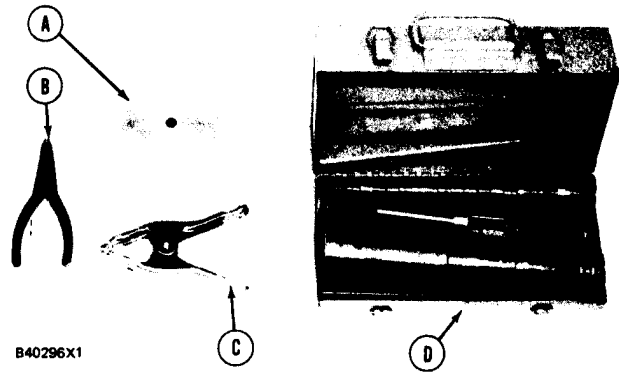

GOVERNOR

NOTE: Make a replacement of shield (7) any time it is removed.

5. Install shield (7) on the carrier and use tool (A) to push the shield against its seat. Use a hammer and punch to move the metal (stake) two places on the side of the shield 180° ± 5° apart next to the holes in the shield.

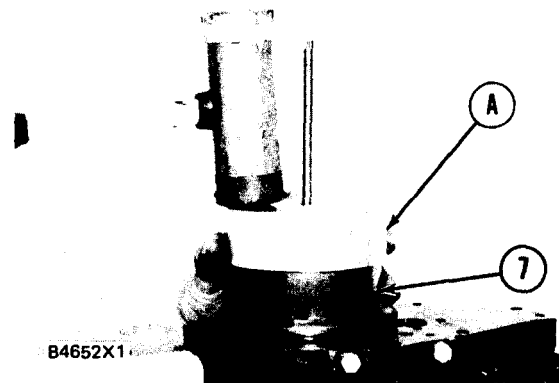

6. Install one race (9), bearing (10), the other race (9) and use tool (B) to install the ring on riser (8) as shown.

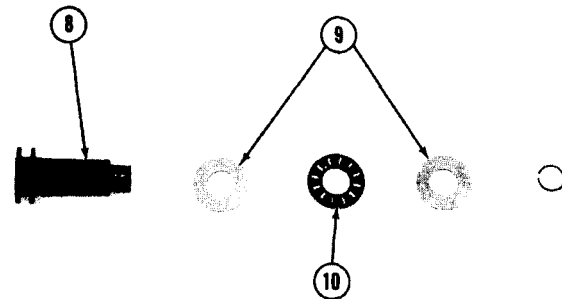

7. Install riser (8) and spring (overfueling spring) on the governor shaft as shown.

8. Assemble the dashpot as follows:
 - a) Install spring (12) on seat (11) and install seat (13) in spring (12).
 - b) Put spool (14) and ring (15) in position on seat (13) and use tool (B) to install snap ring (16) to hold them in place.

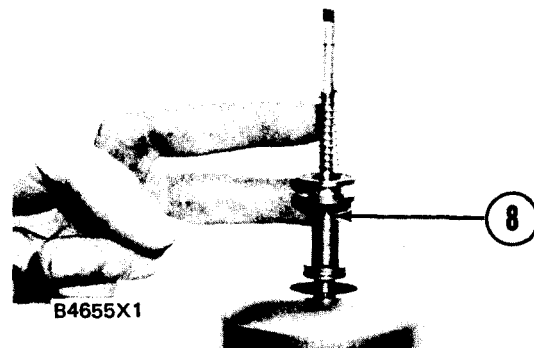

9. Install dashpot assembly (17) on the governor shaft as shown.

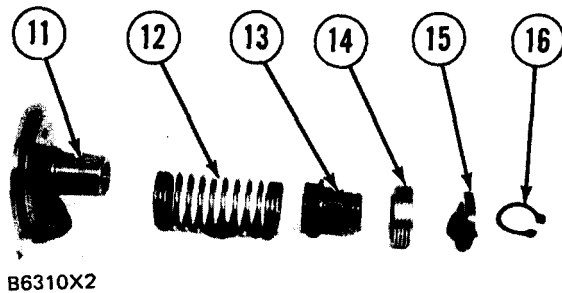
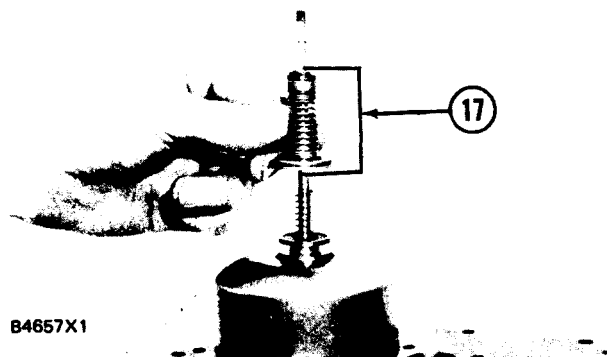

GOVERNOR

10. Install ring (21) in the lower groove in the governor shaft. Install one sleeve (20), spring (19), the other sleeve (20) and bearing (18) on the governor shaft as shown.

NOTE: Spring (19) is used to put a preload on the thrust bearing on the camshaft in the fuel injection pump housing.

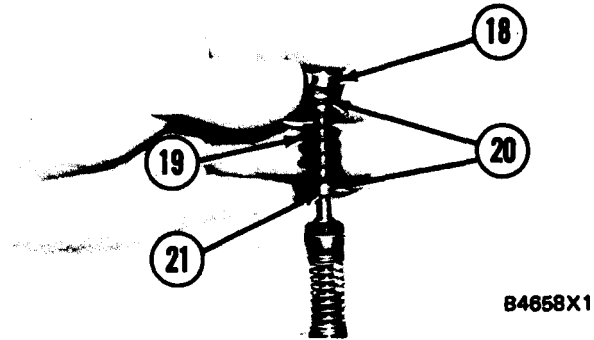

B4658X1

11. Use tool (C) to hold spring (19) in compression and install ring (22) in the groove in the governor shaft. Remove tool (C).
12. Put lever (27) in position on governor servo (23) and install pin (24) to hold the lever in place. Use a hammer and chisel to move the metal (stake) four places 90. apart on the outside surface on both legs of the governor servo to hold pin (24) in place.

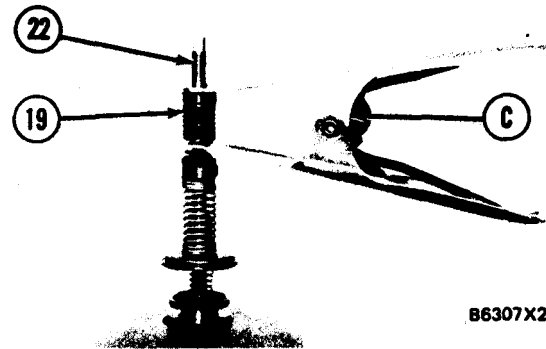

B6307X2

13. Install the O-ring seal on sleeve (25). Install piston (26) and sleeve (25) in the governor servo as shown.

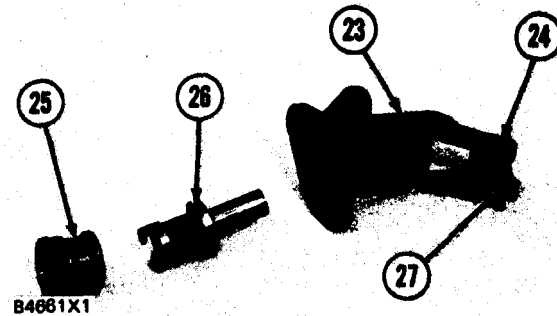

B4661X1

15. Install one locking (32) in the groove near the center of valve (28). Put sleeve (29), spring (broken link spring) (30) and seat (31) in position on valve (28) and install the other locking (32) to hold them in place.

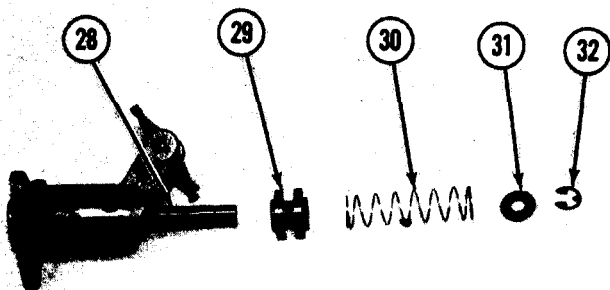

B6303X2

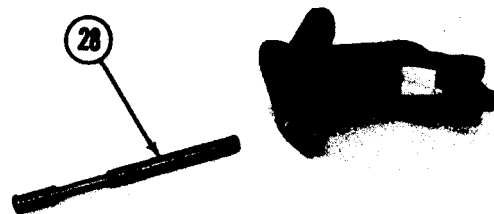

B4662X1

GOVERNOR

16. Put the governor servo in position on the fuel injection pump housing with piston (26) engaged over rack (33) and install the bolts that hold the governor servo in place.

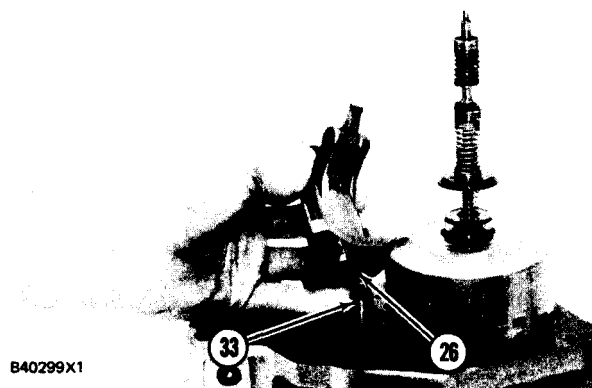

17. Install torque rise adjustment screw (36) in collar (34) as shown and install locknut (35) on the screw.

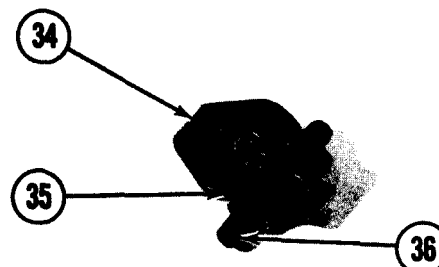

18. Install bolt (38) in block (40) as shown. Install spring (37) on bolt (38) as shown. Put collar (34) in position on bolt (38) with the hole in the collar in alignment with the notch in bolt (38) and install bolt (39) to hold the collar in place.

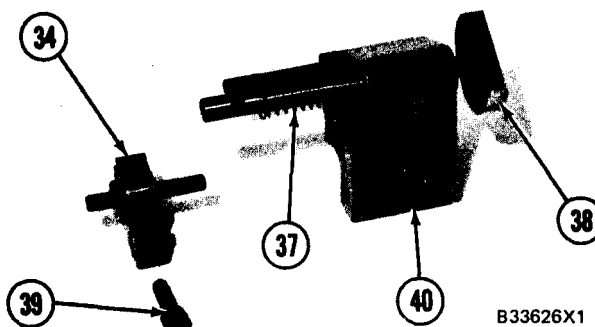

19. Put block (40) in position on housing (41) with the holes in the block in alignment with dowels (42). Install the bolts that hold the block in place.

20. Assemble the torque control group as follows:
 - a) Install bar (47), contact (44), spacer (48) on insulator (43) as shown.
 - b) Install retainer (46), bar (49) and the insulator assembly on bolts (45) as shown.

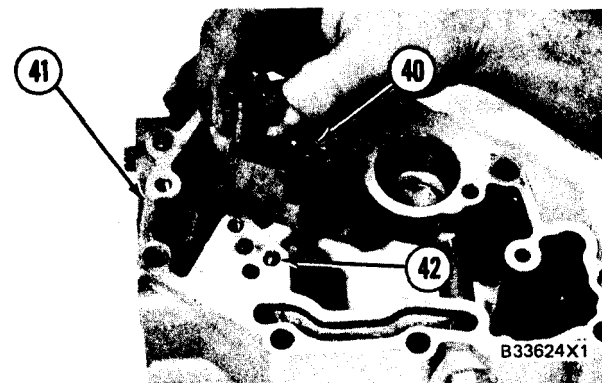
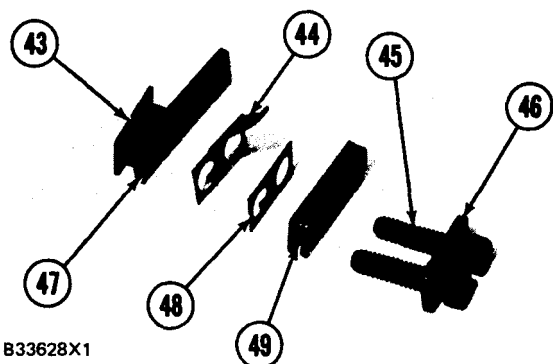

GOVERNOR

21. Install torque control group (50) on block (40) as shown.

WARNING

If housing (41) is installed with the flange on bolt (38) on the wrong side of the dashpot, the riser in the governor will be held in the maximum fuel delivery position. To prevent possible personal injury make sure housing (41) is installed on the fuel injection pump housing with the flange on bolt (38) behind the dashpot.

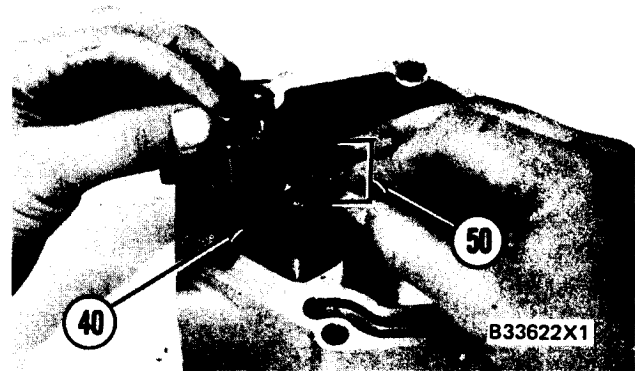

22. Install gasket (51) on the fuel injection pump housing. Put housing (41) in position on the fuel injection pump housing with bolt (38) behind the dashpot as shown. Install the bolts that hold housing (41) in place.
23. Use tooling (D) to install lip type seal (52) in the governor outer housing with the lip in as shown.
24. Install adjustment screw (53) and the locknut for the high idle adjustment.
25. Make a replacement of screen assembly (54) and seal for fuel ratio control.
26. Install an O-ring seal on body (56) for the dashpot adjustment and install the body in the housing.
27. Install gasket and cover (57) on the housing.
28. Install contact (55) in the housing and tighten to a torque of 4.5 ± 0.6 N·m (40 ± 5 lb.in.).
29. Install check valve (58) in the housing as shown.

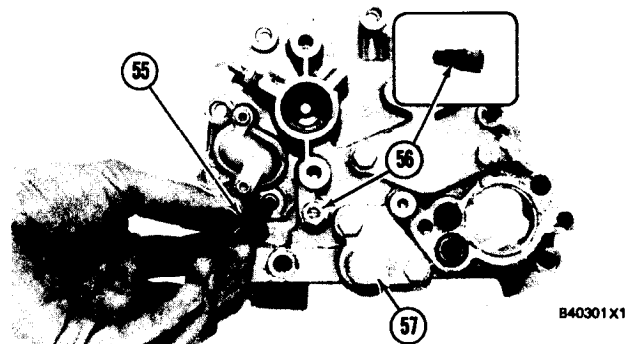
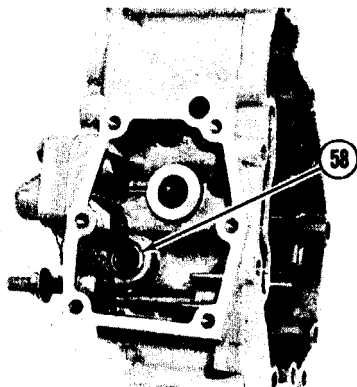
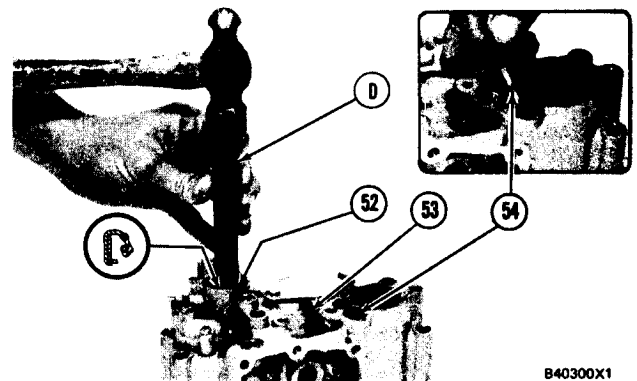
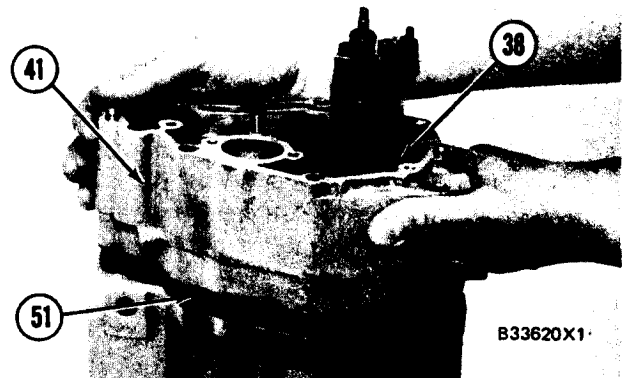

GOVERNOR

29. Put lever (59) in position in the housing as shown and install shaft (60) to hold the lever in place.

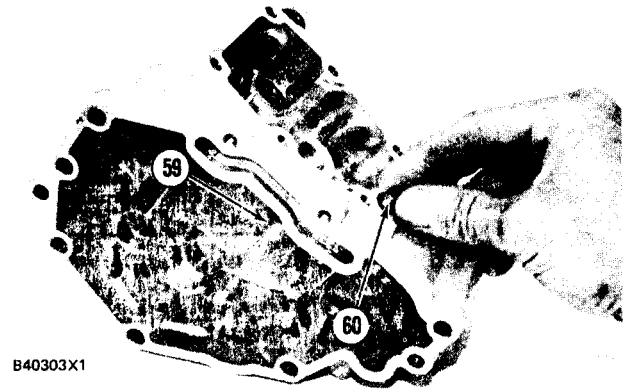

30. Install spring (63) in shaft assembly (64). Install pin (61) in the shaft assembly (64) with the tip of the pin engaged in the hole in spring (63). Install pin (62) in the shaft assembly to hold pin (61) in place.

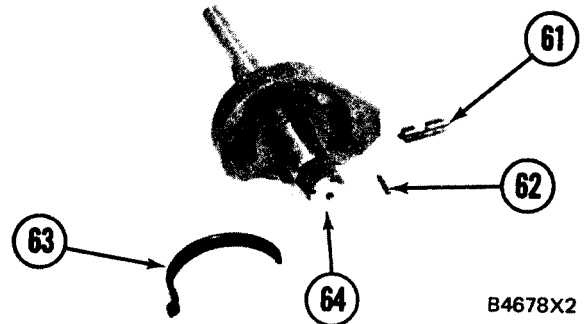

31. Put stop (67) and plates (65) in position on shaft assembly (64) and install pins (66) to hold the plates and stop in place. Install snap rings (68) to hold pins (66) in place.

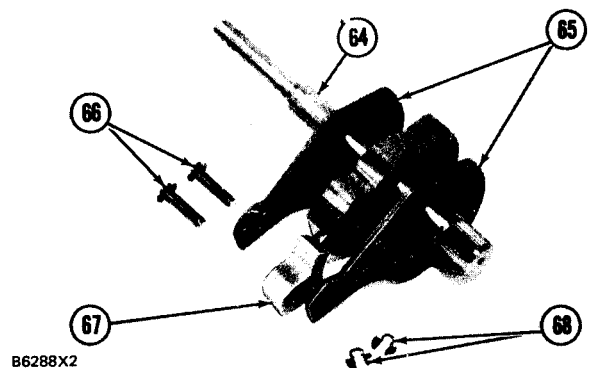

32. Put levers (69) and (70) in position in the housing as shown and install shaft assembly (64) to hold the levers in place.

33. Install adjustment screw (71) and the locknut for the low idle adjustment in the housing. Install spring (72) in the hole in the shaft assembly and in the housing.

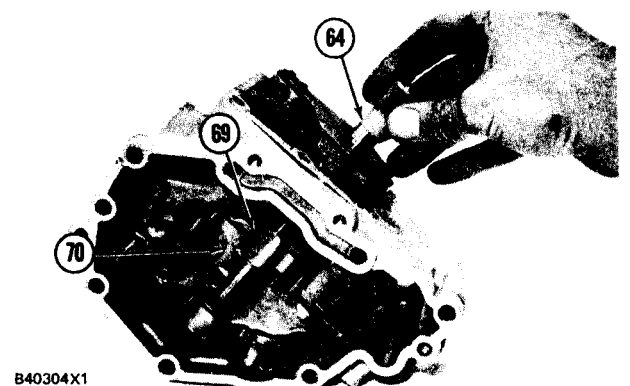
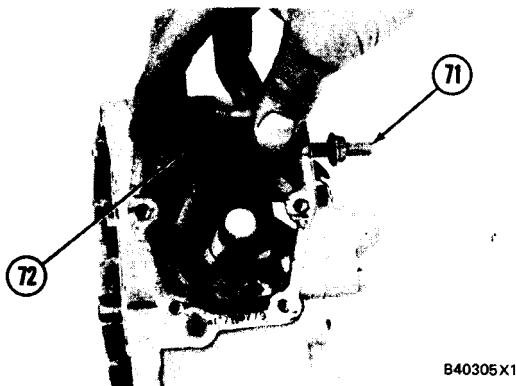

GOVERNOR

34. Use tooling (D) to install the lip type seal in cover (73) with the lip in as shown.

35. Put the gasket and cover (73) in position on the housing and install the bolts that hold it in place.

NOTE: Make sure the seal, washers and spring are on top of the lever as shown. These parts must be kept in this position when housing (79) is put in position on the inner governor housing.

CAUTION

Flat washer (77) must be installed between wave washers (76).

36. Install the governor spring assembly on guide (75) as follows: Install seat (78), one wave washer (76), flat washer (77), the other wave washer (76) and spring (74) on guide (75) as shown.

37. Put the gasket and housing (79) in position on the inner governor housing and install the nine bolts that hold it in place.

NOTE: For models 950BNSCE and 950BSCE, lever will be installed when housing is installed on engine. Go to Step 39.

38. Install governor control lever (80).

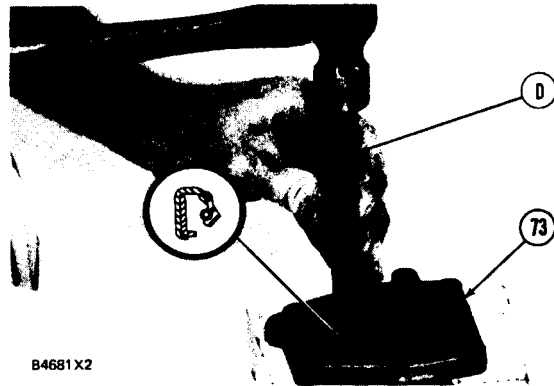

B4681X2

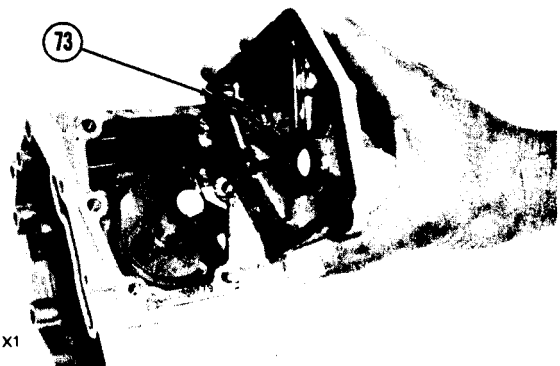

B40306X1

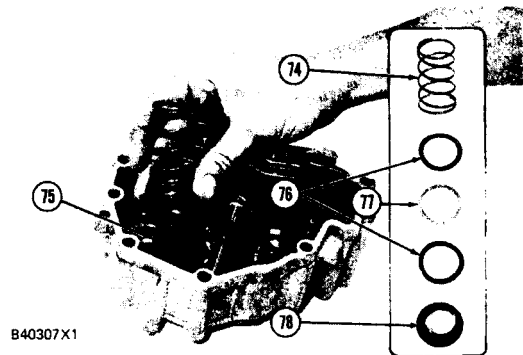

B40307X1

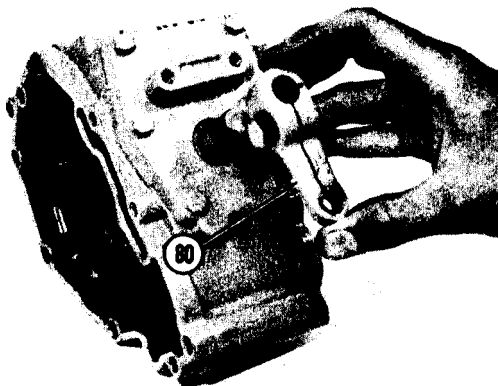

B40309X1

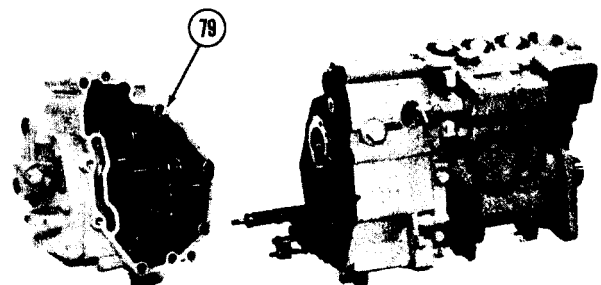

B40308X1

ENGINE

GOVERNOR

39. Install new O-ring seals (81). Install the fuel ratio control. Be sure the rod on the fuel ratio control engages the groove on lever (82).
40. Install the fuel shutoff solenoid.
41. Make governor adjustments. See GOVERNOR ADJUSTMENTS in TESTING AND ADJUSTING.

end by:

- a) install Tachometer Drive
- b) install fuel transfer pump
- c) install fuel injection pump housing and governor

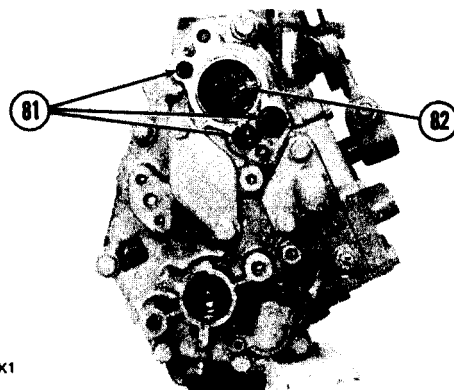

B40310X1

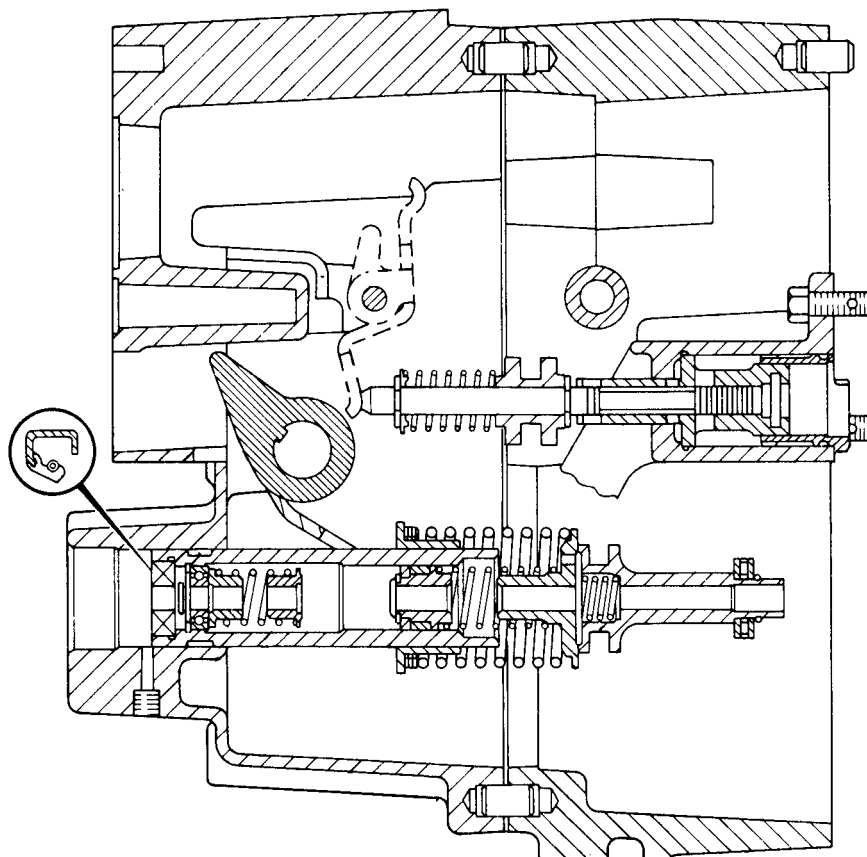

B40324X1

VALVE COVER

REMOVE VALVE COVER

1107-11

1. Put marks on wire assembly (1) for correct connection.
2. Disconnect wires (1) from the sending unit.
3. Remove the bolts and move wire assembly (1) away from the valve cover.
4. Loosen clamps (2) and slide the hose on the breather tube. Remove breather (3) from the valve cover.
5. Turn breather tube (4) away from valve cover (5).
6. Remove the bolts, valve cover (5) and the gasket from the engine.

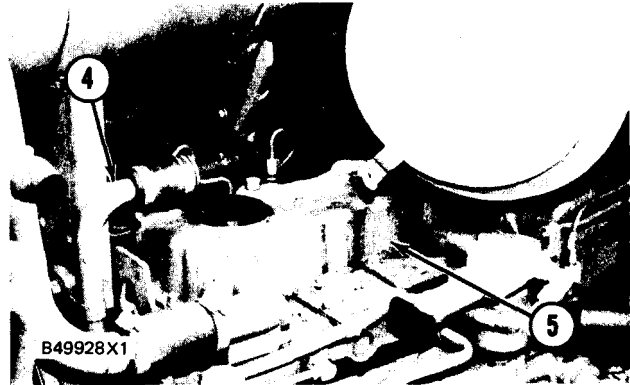
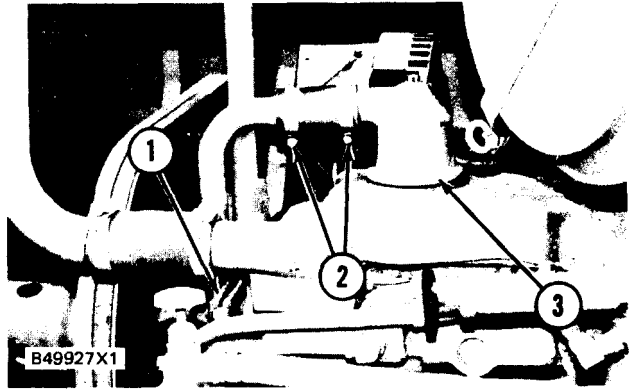

INSTALL VALVE COVER

1107-12

1. Install a new gasket for the valve cover if needed. Use 5H2471 Cement to hold the new gasket to the valve cover.
2. Put valve cover (1) in position on the cylinder head. Install the bolts that hold the valve cover in place. Tighten the bolts in number sequence shown to a torque of 11 ± 3 N·m (8 ± 2 lb. ft.).
3. Put breather (3) in position on the valve cover. Tighten the bolts to a torque of 14 ± 3 N·m (10 ± 2 lb.ft.).
4. Put breather tube (2) in position and slide the hose into the breather. Tighten the hose clamps.
5. Put wire assembly (4) in position and connect the clips to the engine.
6. Connect the wire assembly to the sending unit.

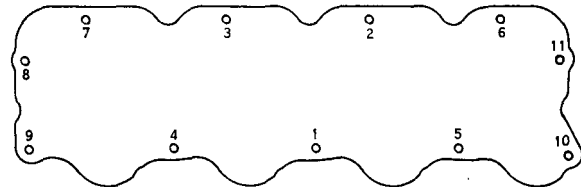
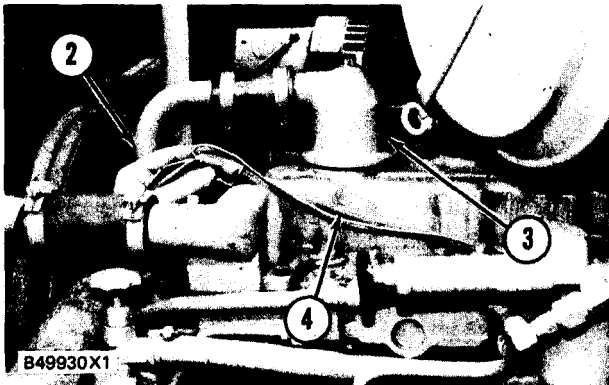
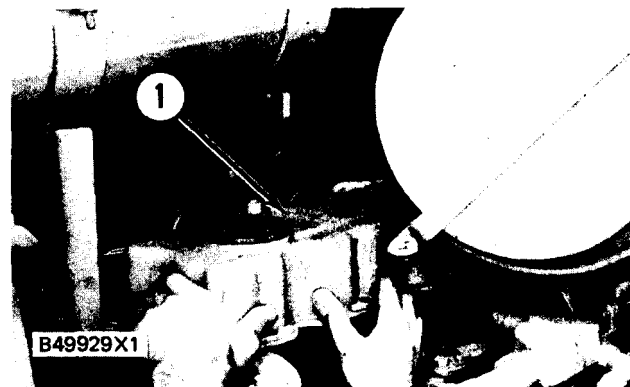

T98226

ROCKER SHAFT AND PUSH RODS

REMOVE ROCKER SHAFT AND PUSH RODS 1102 & 1208-11

start by:

a) remove valve cover

1. Remove four bolts (1) and the washers from the rocker shaft.
2. Remove rocker shaft (2) from the cylinder head.
3. Remove push rods (3) from the engine.

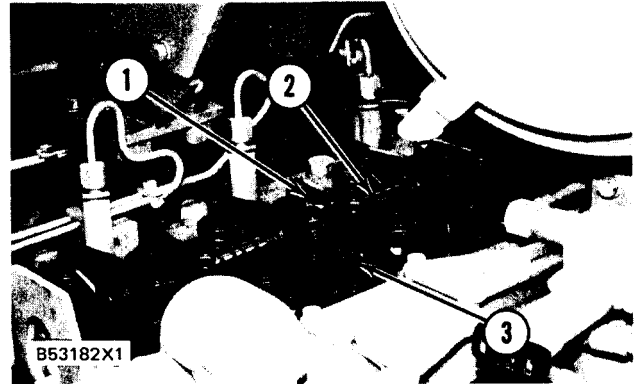

INSTALL ROCKER SHAFT AND PUSH RODS 1102 & 1208-12

1. Loosen adjusting screws (1) on the rocker arms for valve clearance. This will prevent a bent valve or push rod at installation.
2. Install push rods (3) as shown.
3. Put rocker shaft (2) in position on the cylinder head.
4. Put 5P3931 Anti-Seize Compound on the threads of the bolts (except the rear bolt fly-wheel end) that holds the rocker shaft in position. Install the four bolts and washers.

NOTE: Make sure the rocker arms are on all of the push rods.

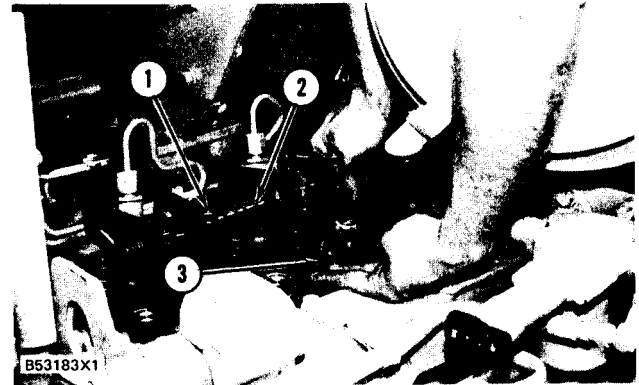

CAUTION

The dowels on each end of the rocker shaft assembly must make an alignment with the holes in the cylinder head assembly. If the dowels and holes are not in alignment when the rocker shaft assembly is tightened, damage to the rocker shaft assembly will be the result.

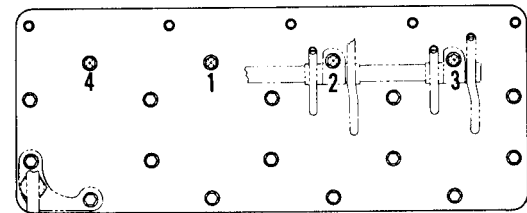

5. Tighten the bolts for the rocker shaft as follows:
 - a) Tighten bolts in number sequence to a torque of 155 N·m (115 lb.ft.).
 - b) Tighten bolts again in number sequence to a torque of 250 ± 17 N·m (185 ± 13 lb. ft.).
 - c) Tighten bolts again and for the last time in number sequence (hand tighten only) to a torque of 250 ± 17 N·m (185 ± 13 lb. ft.).
6. The assembled length of springs (4) at both ends of the rocker shaft must be 1.50 ± 0.25 mm ($.059 \pm .010$ in.). Remove or install the washers behind springs to change the assembled length of the springs.
7. Make adjustments until the intake valve clearance is 0.38 mm (.015 in.) and the exhaust valve clearance is 0.64 mm (.025 in.). See ENGINE VALVE LASH as shown in MAINTENANCE GUIDE. Tighten the locknuts for the adjusting screws to a torque of 29 ± 7 N·m (21 ± 5 lb. ft.).

end by:

a) install valve cover

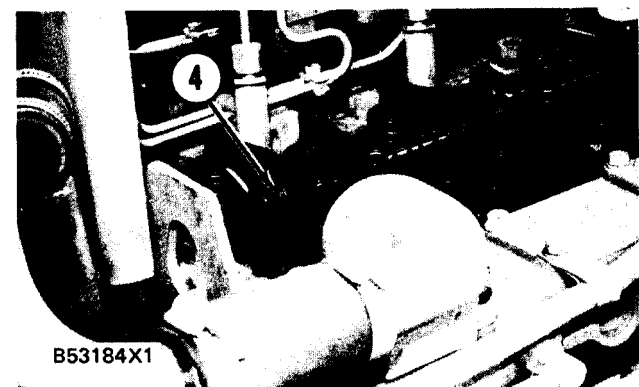

ROCKER SHAFT

DISASSEMBLE ROCKER SHAFT 1102-15

start by:

a) remove rocker shaft and push rods

1. Remove O-ring seal (1) from the rear support bracket.

NOTE: A replacement of the O-ring seal must be made each time the head bolt is removed from the rear support bracket.

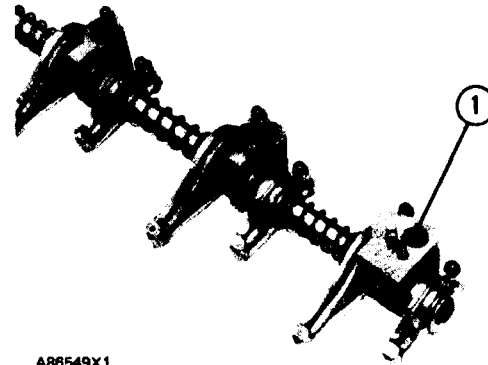

A88549X1

2. Remove retainer ring (6), washer (5), spring (4) and washers (3) from each end of rocker shaft. Make a note of the number of washers (3) used at each end of the shaft. Remove rocker arms (2) from each end of the rocker shaft. All the rocker arms, springs, washers and brackets, except rear support bracket, can be removed from the shaft.

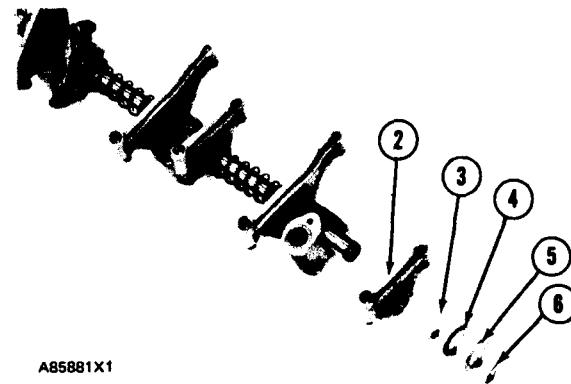

A85881X1

3. Remove pin from rear support bracket with a hammer and punch. Remove rear support bracket (7) from shaft.
4. Remove plugs from each end of the shaft if necessary.

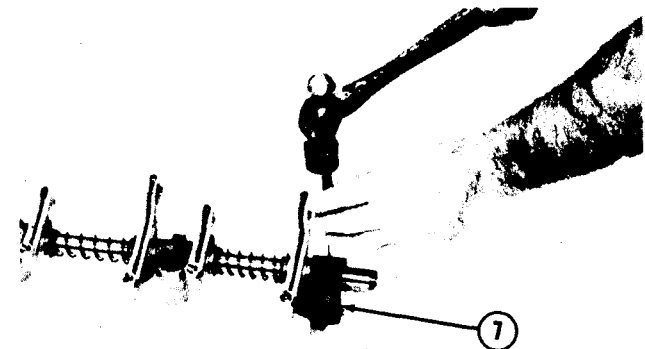

A85882X1

ROCKER SHAFT**ASSEMBLE ROCKER SHAFT 1102-16**

1. Install rocker arms (5), brackets (1), washers (4) and springs (2) on the rocker shaft.
2. Install rear support bracket (6) on rocker shaft. Make sure hole in rear support bracket is in alignment with hole in rocker shaft.
3. Put pin (3) in position in the bracket.

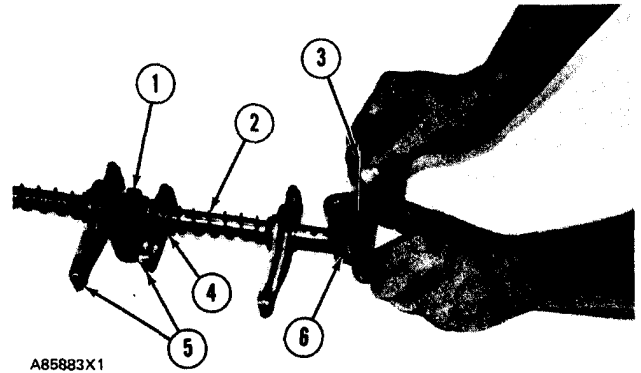

4. Install pin (3) through bracket and shaft with a hammer.
5. Pin (3) must extend 9.60 mm (.378 in.) above the bracket.
6. Install O-ring seal (7) in the rear support bracket. Install rocker arm (8), the original number of washers, spring, washer and retainer ring on the rocker shaft.

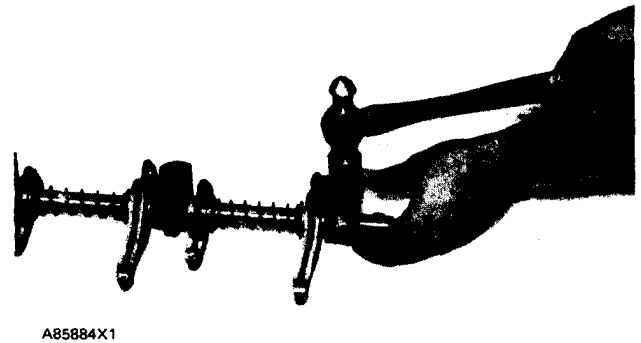

7. Install the front support, rocker arm, original number of washers, spring, washer and retainer ring on the rocker shaft.
8. Install the plugs in each end of the rocker shaft if they were removed.

end by:

- a) install rocker shaft and push rods

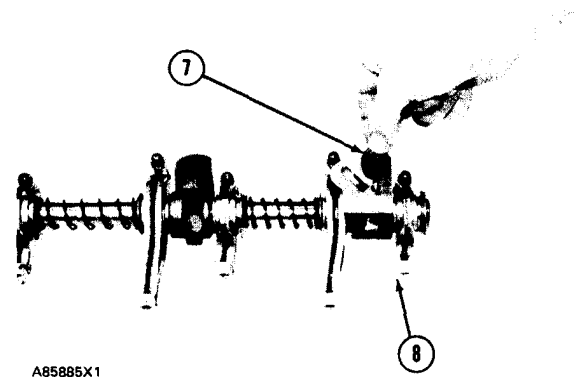

CYLINDER HEAD

REMOVE CYLINDER HEAD

1100-11

start by:

- a) remove muffler
- b) remove air cleaner housing
- c) remove fuel priming and primary filter pump group
- d) remove rocker arm and push rods
- e) remove exhaust manifold
- f) remove water regulator
- g) remove fan drive

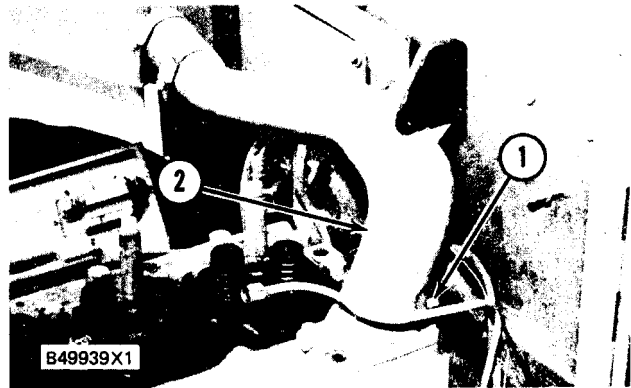

1. Disconnect tube (1) from elbow (2).

2. Remove the bolts and elbow (2) from the cylinder head.

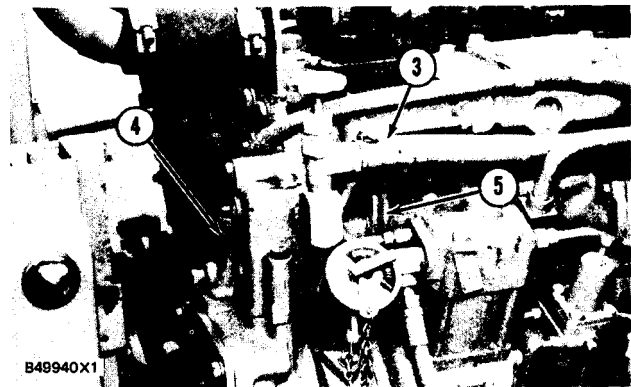

3. Loosen the clamp and disconnect hose (3) from water pump elbow (4).

4. Loosen clamps (5). Remove the bolts, water pump elbow (4) and gasket from the water pump.

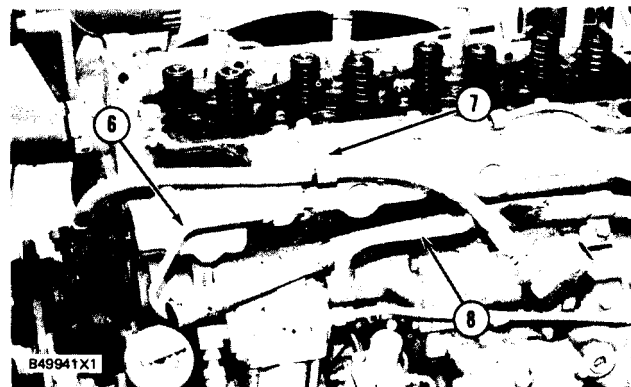

5. Remove the bolt and disconnect clamp (7) from the cylinder head.

6. Remove tube assemblies (6) and (8) from the engine.

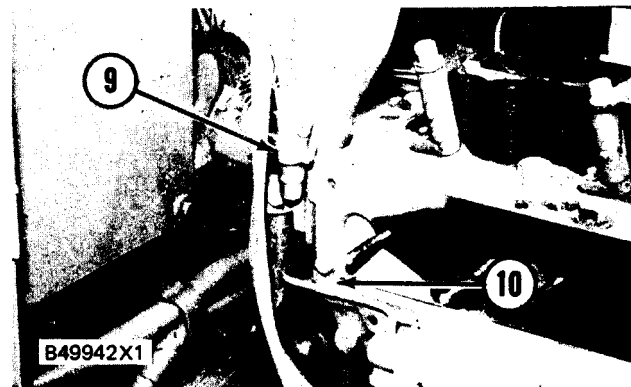

7. Remove the bolt and disconnect clip (10) from the cylinder head.

8. Remove the bolt from the lifting bracket and disconnect wire harness (9). Install the bolt on the lifting bracket.

CYLINDER HEAD

9. Fasten a hoist to cylinder head (11). Remove the bolts and cylinder head (11) from the engine. The weight of the cylinder head is 61 kg (135 lb.).

CAUTION

Do not put the cylinder head down on a flat surface. This can cause damage to the fuel injection valves.

INSTALL CYLINDER HEAD

1100-12

NOTE: Always install a new gasket between the spacer plate and cylinder block-before the cylinder head is installed. See REMOVE SPACER PLATE.

1. Thoroughly clean the spacer plate and bottom surface of the cylinder head. Install a new head gasket, water ferrules (1) and the O-ring seal on the hollow dowel.
2. Install a new gasket on the water inlet elbow.
3. Fasten a hoist to cylinder head and put it in position on the cylinder block. Make sure the cylinder head is in alignment with the dowels in the cylinder block.
4. Put 2P2506 Anti-Seize Compound Thread Lubricant on all the head bolts and rocker shaft bolts. Install the head bolts and washer that hold the cylinder head in place but do not tighten at this time.
5. Remove the bolt from the lifting bracket and connect wire harness (2) to it. Install the bolt on the lifting bracket.
6. Connect clip (3) to the cylinder head.
7. Install tube assemblies (4) and (6) to the engine as shown.
8. Connect clip (5) to the cylinder head.

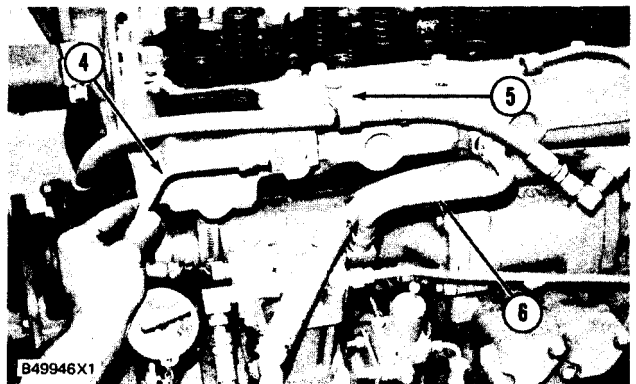
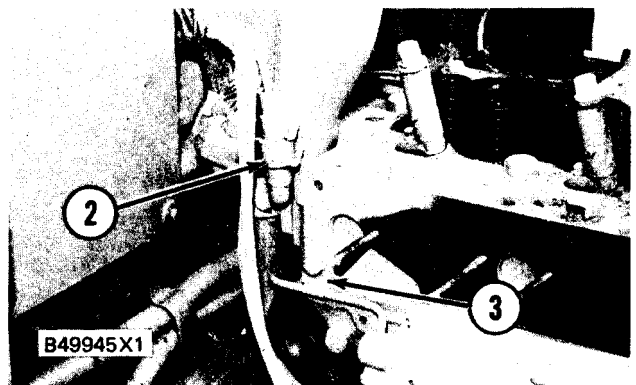
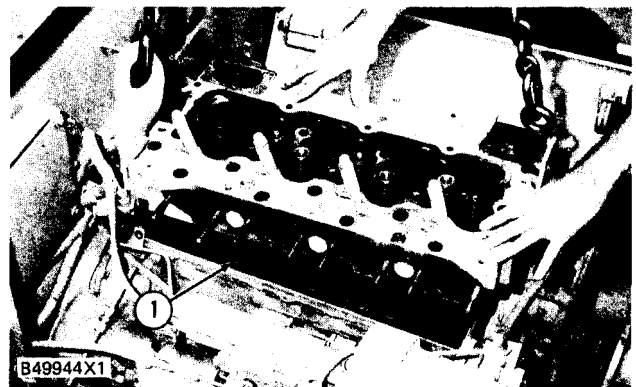
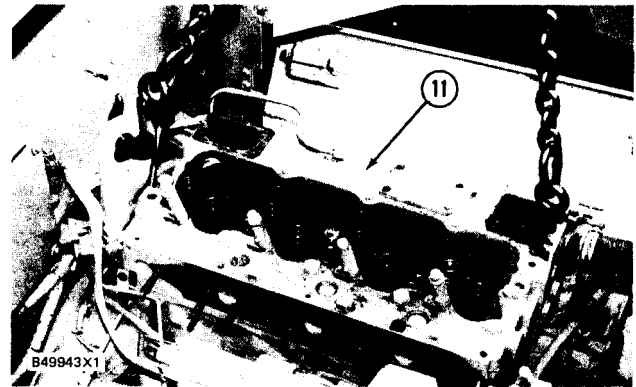

CYLINDER HEAD

9. Install the gaskets and water pump elbow (7) to the engine. Make sure to tighten the hose clamps.
10. Connect hose (8) and tighten the clamp.
11. Install the elbow to the cylinder head and connect the tube to the elbow.
12. Install push rods (10) and rocker shaft (9). Install the bolts and washers.
13. Tighten the bolts as follows:
 - a) Tighten the bolts 1 through 18 in number sequence to a torque of 155 N·m (115 lb. ft.).
 - b) Tighten bolts 1 through 18 again in number sequence to a torque of 250 ± 17 N·m (185 ± 13 lb. ft.).
 - c) Tighten bolts 1 through 18 again in number sequence (hand tighten only) to a torque of 250 ± 17 N·m (185 ± 13 lb. ft.).
 - d) Tighten bolts A through E in letter sequence to a torque of 43 ± 7 N·m (32 ± 5 lb. ft.).
 - e) Tighten bolts A through E again in letter sequence to a torque of 43 ± 7 N·m (32 ± 5 lb. ft.).
14. Make an adjustment until the intake valve clearance is 0.38 mm (.015 in.) for the intake and 0.64 mm (.025 in.) for the exhaust. See VALVE CLEARANCE in TESTING AND ADJUSTING.

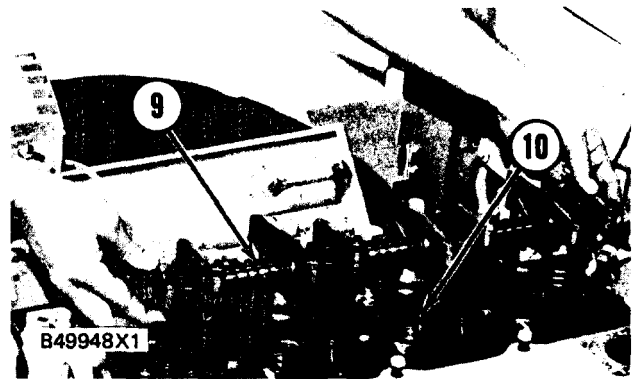
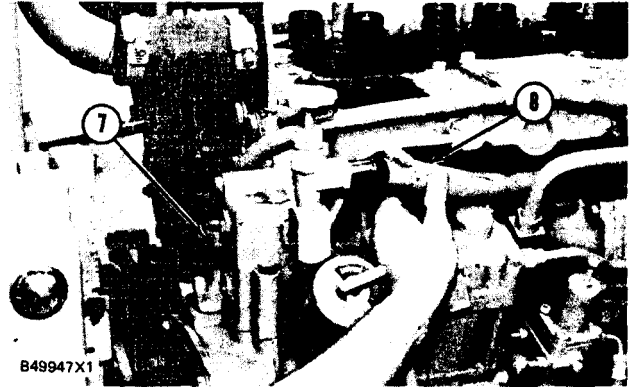

end by:

- a) install fan drive
- b) install water regulator
- c) install exhaust manifold
- d) install fuel priming and primary filter

WARNING

If NBC exposure is suspected, all air filter media should be handled by personnel wearing protective equipment. Consult your unit NBC Officer or NBC NCO for appropriate handling or disposal instructions.

- e) install air cleaner housing
- f) install muffler

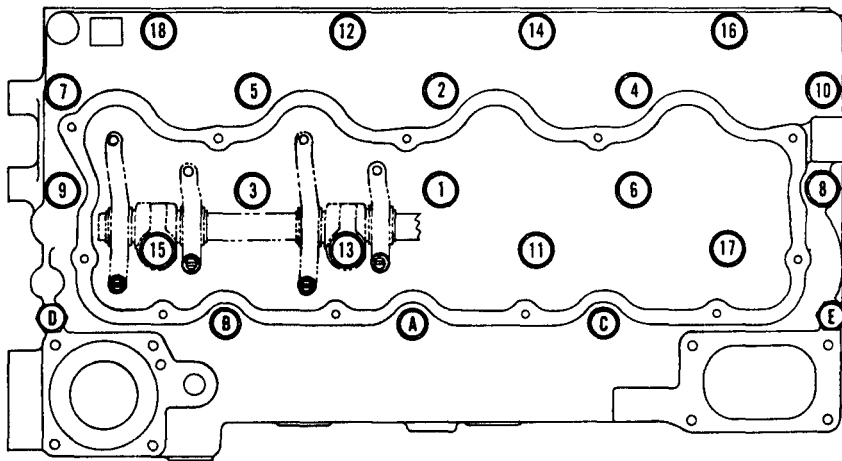

CYLINDER HEAD

DISASSEMBLE CYLINDER HEAD

Tools Needed	A	B	C	D	E
6V3129 Nozzle Puller Group	1				
5S1330 Valve Spring Compressor		1			
8S2263 Valve Spring Tester			1		
7S8859 Guide Driver				1	
9S3080 Valve Seat Insert Group					1

start by:

a) remove cylinder head

1. Use tooling (A) to remove the fuel injection nozzles from the cylinder head.
2. Remove brackets (1) for the fuel injection line clamps.
3. Remove water temperature sending unit (2).
4. Remove lifting brackets (3).
5. Remove and install water directors (4) as follows:
 - a) Remove old water directors (4) from the cylinder head.
 - b) Clean the cylinder head.
 - c) Install new water directors in the cylinder head with the notch in the water director in alignment with the "V" mark on the cylinder head. Install the water directors to a depth of 0.8 ± 0.6 mm ($.031 \pm .023$ in.) below the surface of the cylinder head.
6. Use tooling (B) to put valve spring (6) in compression. Remove locks (5) from the valve stem. Carefully remove tooling (B), rotocoil, spring and valve. Put identification on the valves with respect to their location in the cylinder head. Remove the remainder of the valves the same way.
7. Use tooling (C) to check the valve springs. The spring force is 257 ± 25 N (57.6 ± 5.6 lb.). The length of the spring under test force is 44.86 mm (1.766 in.). The free length after test is 52.1 mm (2.05 in.). Check all the valve springs.

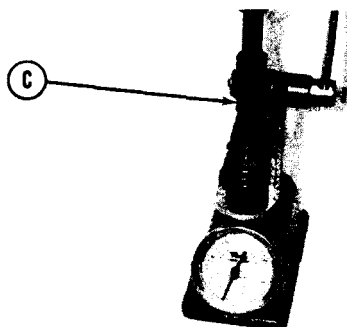
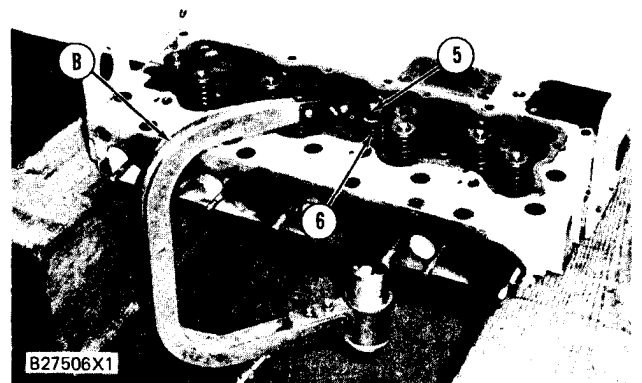
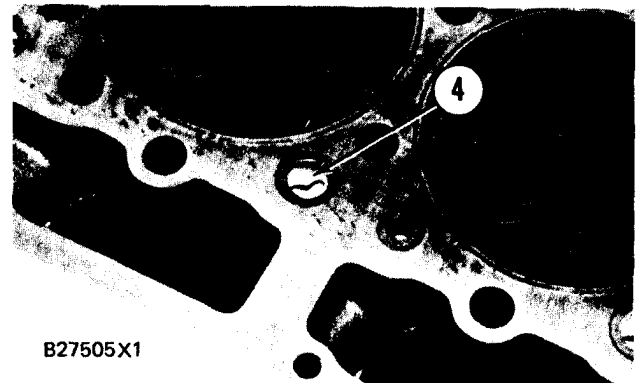
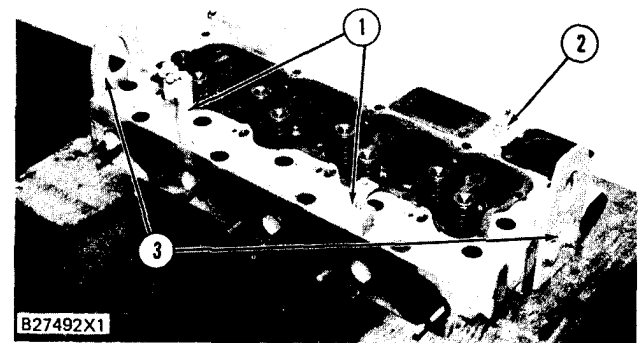
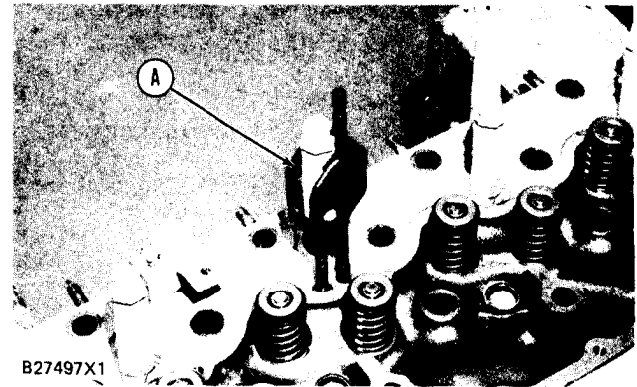

CYLINDER HEAD

8. Use tooling (D) to remove the valve guides from the cylinder head.
9. Use tooling (E) to remove the valve seat inserts from the cylinder head.
10. Clean and remove any rough places (burrs) from the valve seat bores.

NOTE: For reconditioning information of the cylinder head see SERVICE TRAINING MEETING GUIDE Form JEG02327.

ASSEMBLE CYLINDER HEAD 1100-16

Tools Needed	A	B	C	D	E
9S3080 Valve Seat Insert Group	1				
7S8859 Guide Driver		1			
7S8858 Bushing		1			
5S1330 Valve Spring Compressor			1		
5S1322 Lock Inserter				1	
8S2252 Carbon Seal Tool*					1

*The 8S2252 Carbon Seal Tool must have a modification made to it before it can be used with the 8N7002 Fuel Injection Nozzle. Special Instruction Form No. SEHS7292 has the information needed to make the modification to the tool.

1. Lower the temperature of (freeze) the new valve seat inserts, Use tooling (A) to install the new valve seat inserts. Do not increase the diameter of the extractor in the valve seat insert when the insert is installed in the cylinder head.
2. Put clean oil on the outside diameter of the valve guides. Use tooling (B) to install valve guides (1) in the cylinder head. Tooling (B) will install the valve guides so dimension "X" will be correct. Dimension "X" must be 22.23 ± 0.25 mm ($.875 \pm .010$ in.). The minimum inside diameter of the valve guides after installation must be 9.456 mm (.3723 in.). Clean the valve guides after installation.
3. Grind the valve seat inserts according to specifications given in SPECIFICATIONS section.

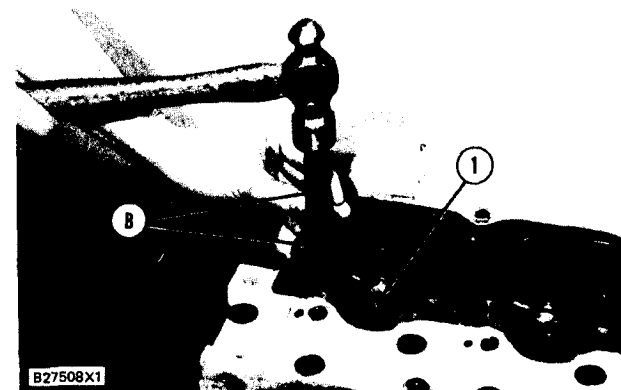
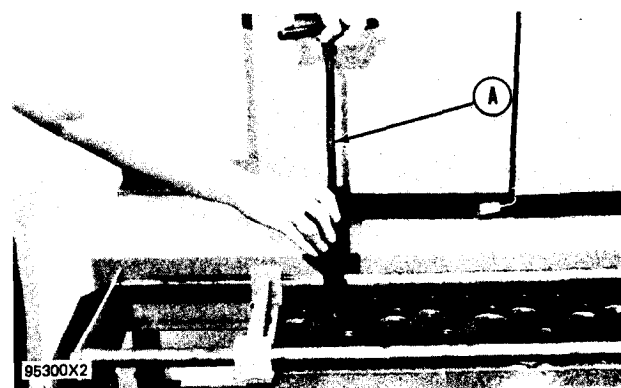
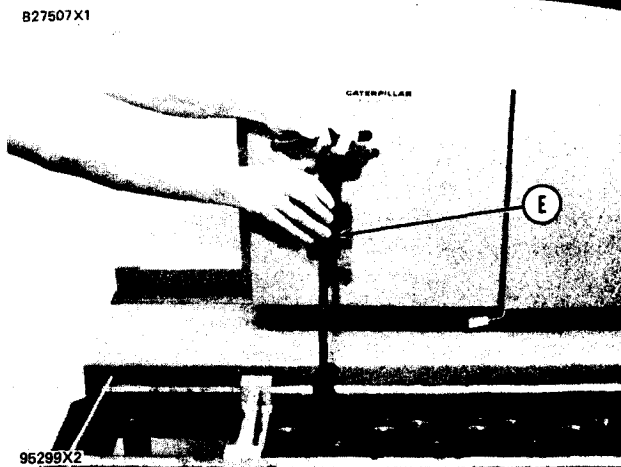
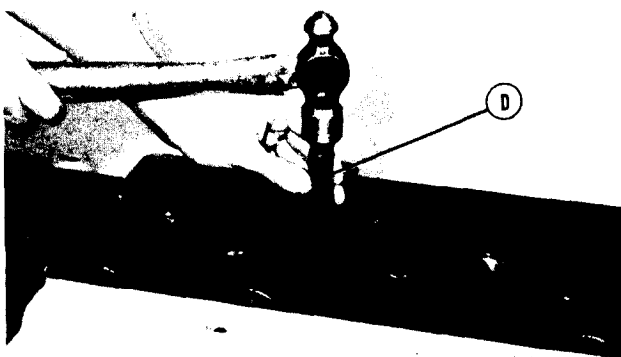
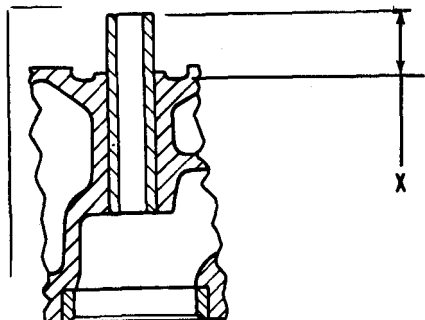

CYLINDER HEAD

4. Put clean engine oil on the valve stems. Install the valve, spring and rotocoil in the cylinder head.

WARNING

To prevent possible personal injury, make sure the locks are in their correct position on the valve stem when the compressor is released.

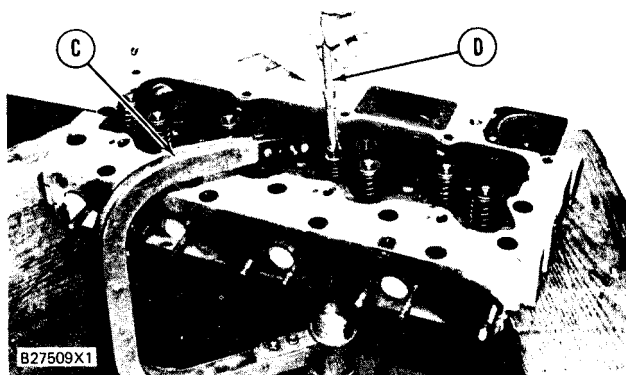

5. Put tooling (C) in position on the valve spring and put the spring in compression. Use tooling (D) to install the locks on the valve stem.
6. Remove tooling (D) and hit the top of the valve with a plastic hammer to be sure the locks are in their correct position on the valve.
7. Do Steps 4, 5 and 6 again for the remainder of the valves.

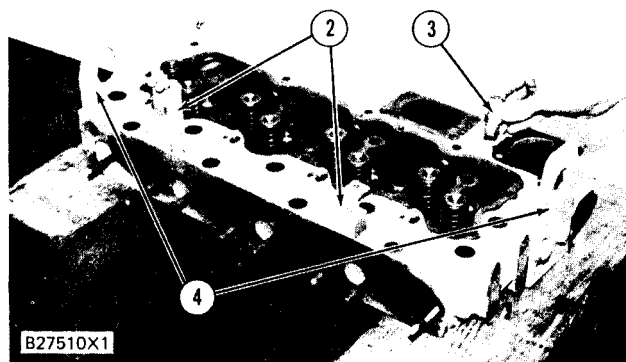

8. Install brackets (2) for the fuel injection line clamps on the cylinder head.
9. Put 5P3413 Pipe Sealant on the threads of water temperature sending unit (3) and install the sending unit in the cylinder head.
10. Install lifting brackets (4) on the cylinder head.

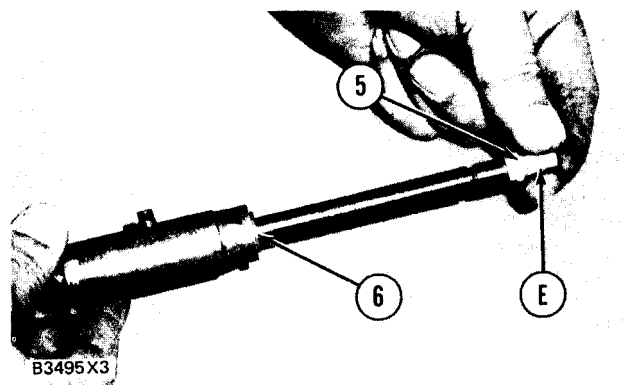

11. Use tool (E) to install carbon dam (5) on the fuel injection nozzles. Install seal (6) on the fuel injection nozzles.
12. Put fuel injection nozzles (7) in position in the cylinder head and install the bolt that holds each nozzle in place.
end by:
a) install cylinder head

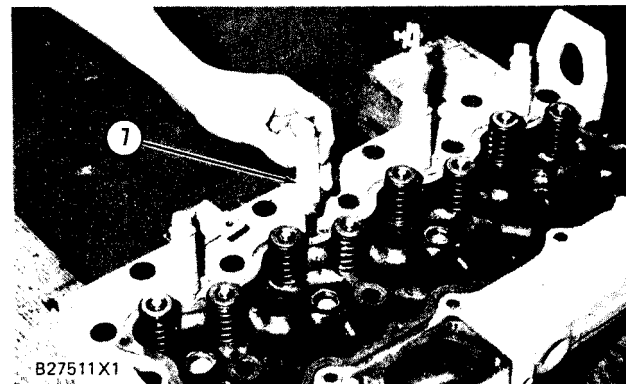

SPACER PLATE

REMOVE SPACER PLATE

1221-11

start by:

a) remove cylinder head

1. Remove sixteen water seals (1) and one O-ring seal (3) from spacer plate (2).

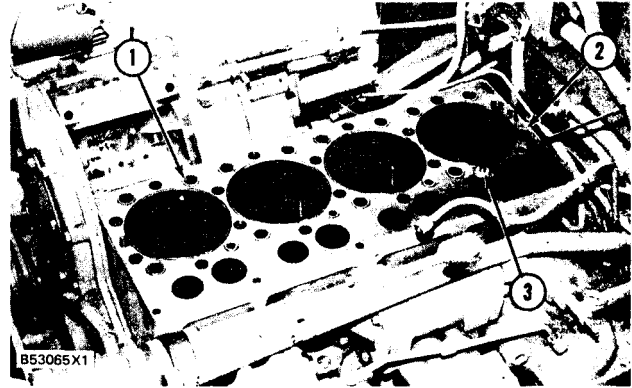

CAUTION

Do not cause damage to the dowels as the spacer plate is removed.

2. Remove spacer plate (2) from the engine block.
3. Remove O-ring seal (5) and gasket (4) from the engine block.

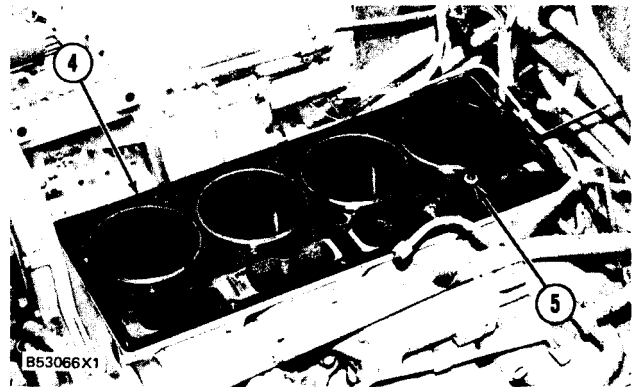

INSTALL SPACER PLATE

1221-12

1. Thoroughly clean the spacer plate and cylinder block surfaces.
2. Put a new gasket (3) and O-ring seal (2) in position on dowel.
3. Put spacer plate (1) in position on the cylinder block.

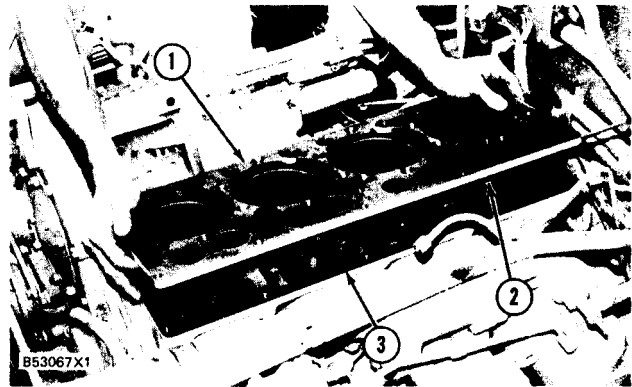

CAUTION

Both surfaces of the spacer plate, top of cylinder block and both sides of the spacer plate gasket must be clean and dry. Gasket adhesive or other substances must not be used on these surfaces.

4. Install new water seals (4) and O-ring seal (5) in the spacer plate.
5. Check the cylinder liner (projection) height. See INSTALL CYLINDER LINERS.

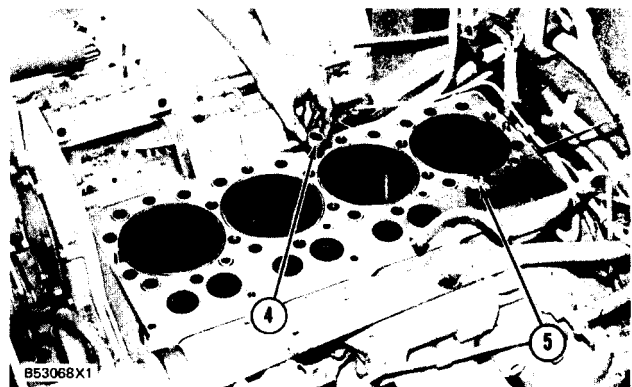

end by:

a) install cylinder head

VALVE LIFTERS, PISTONS

REMOVE VALVE LIFTERS

1209-11

start by:

- a) remove cylinder head
- b) remove oil pan

1. Remove valve lifters (1) with magnet (2).
2. Put identification on each lifter for use at installation of the valve lifters.

INSTALL VALVE LIFTERS

1209-12

1. Put clean engine oil on the valve lifters and camshaft lobes. Install the valve lifters in their original positions in the cylinder block.
- end by:
 - a) install cylinder head

REMOVE PISTONS

1214-11

start by:

- a) remove cylinder head
- b) remove oil pan plate

1. Remove the ring of carbon from the top inner surface of the cylinder liners.
2. Turn the crankshaft until two pistons are at bottom center. Remove connecting rod caps (1) from the two connecting rods.
3. Put tape or pieces of rubber hose over the threads of the connecting rod bolts. This will prevent damage to the crankshaft during removal of the pistons.

CAUTION

Do not let the connecting rods hit the bottom edge of the cylinder liners or the crankshaft during removal and installation of the pistons.

4. Push the piston and connecting rod away from the crankshaft until the piston rings are above the cylinder liner. Remove the two pistons (2) and the connecting rods from the engine.
5. Keep each connecting rod cap with its respective connecting rod and piston. Put identification on each connecting rod as to its location in the engine for use at assembly of the engine.
6. Do Steps 2 through 5 for the remainder of the pistons.

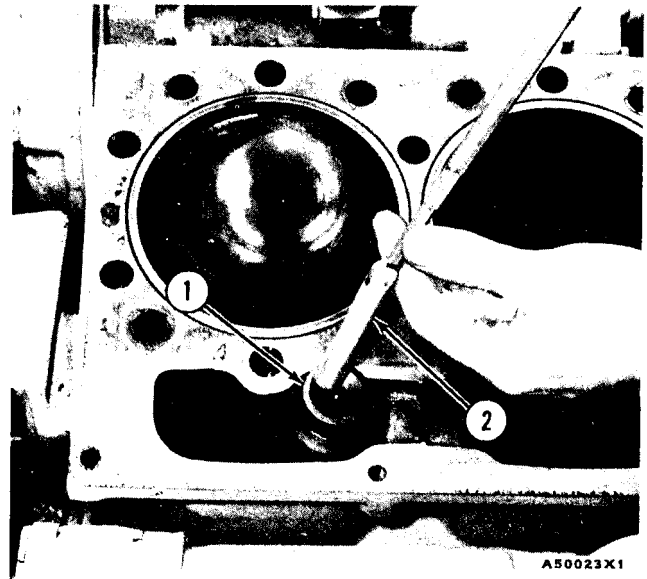

TYPICAL EXAMPLE

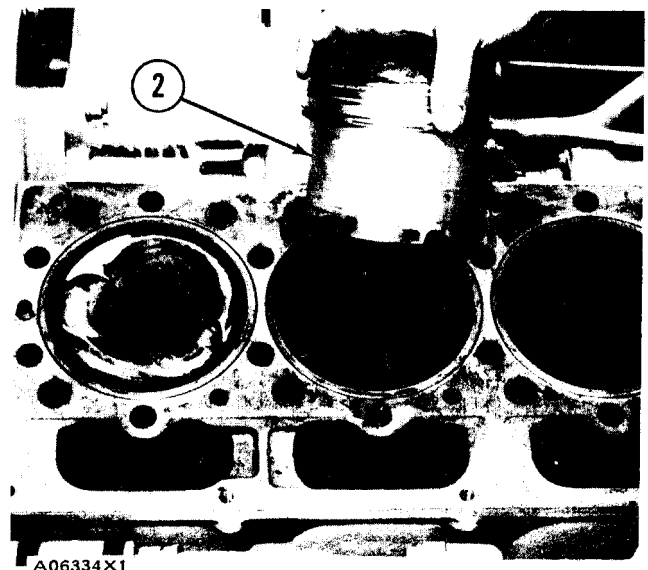
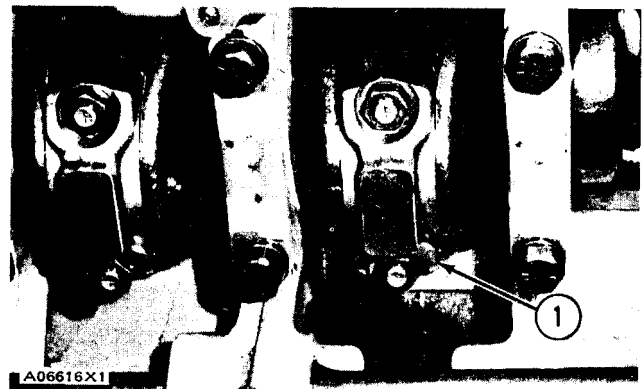

TYPICAL EXAMPLE

PISTONS

INSTALL PISTONS

1214-12

Tools Needed		A
5P3525	Ring Compressor	1

1. Turn the crankshaft until the bearing journals for the pistons to be installed are at bottom center.
2. Put clean engine oil on the crankshaft journals and on the inside of the cylinder liners. Put clean engine oil on the piston rings and connecting rod bearings.
3. Move the rings on the piston until the ring openings are approximate y 90° apart.

CAUTION

Never install the ring compressor on the piston unless the cylinder liner is used as a guide. Damage to the piston rings can be the result.

4. Put ring compressor (A) in position on the cylinder liner. Put the connecting rod and piston in position in the same cylinder liner from which it was removed and into the ring compressor. Make sure the “V” mark on the piston is in alignment with the “V” mark on the cylinder block.
5. Push the piston into place as the connecting rod is put into position on the crankshaft.
6. Put clean engine oil on bearings, bolt threads and surfaces of the nuts that make contact with the connecting rod caps. Put caps (1) in position on the connecting rods and install the nuts. Tighten the nuts to a torque of 40 ± 4 N·m (30 ± 3 lb.ft.). Put a mark on each nut and the end of each bolt. Tighten the nuts 90° more.

CAUTION

When connecting rod caps are installed, make sure the number on the side of the cap is next to and respective with the number on the side of the connecting rod.

7. Follow the same above procedure for installation of the remainder of the pistons.
end by:
 - a) install oil pan
 - b) install cylinder head

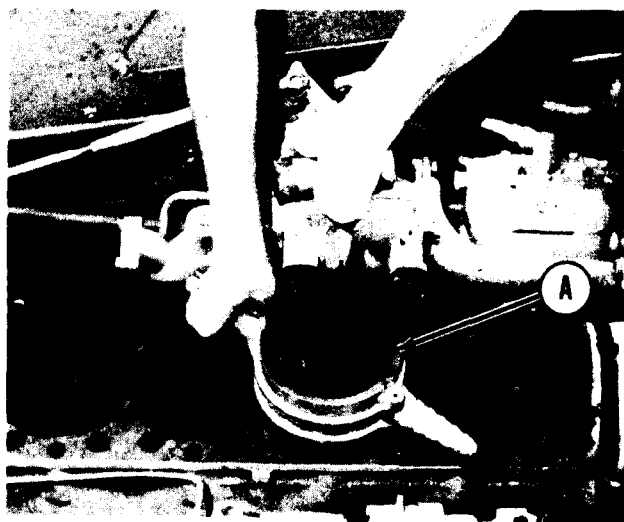

A32803X1

TYPICAL EXAMPLE

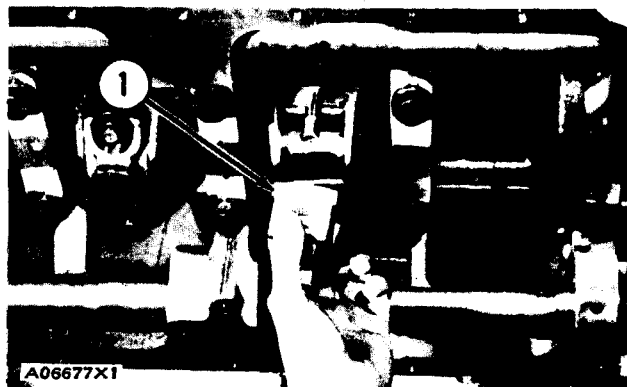

A06677X1

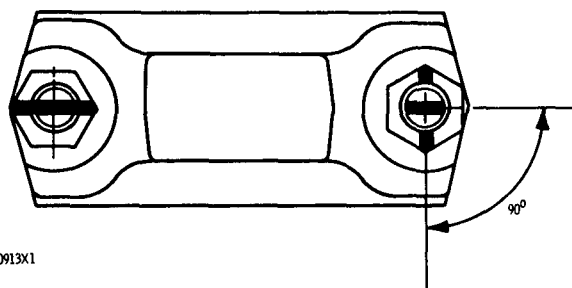

30913X1

PISTONS

DISASSEMBLE PISTONS

1214-15

Tools Needed		A	B
	Ring Expander	1	
5F3639	Press Group		1
8F24	Hose Assembly		1
1P2375	Coupler Assembly		1
1P2376	Coupler Assembly		1
5F8719	Hand Pump (or electric)		1
6V2050	Tool Group		1

start by:

a) remove pistons

1. Remove the rings from the piston with tool (A).
2. Remove the bearings from the connecting rod and connecting rod cap.
3. Remove retaining rings (3), pin (1) and connecting rod (2) from the piston.
4. See USE OF PISTON PIN BEARING REMOVAL AND INSTALLATION TOOLS, SPECIAL INSTRUCTIONS, Form No. SMHS7295-02 for more information of removal and installation of piston pin bearings.
5. Heat the connecting rod to a temperature of 176 to 260°C (350 to 500°F). Put 6V3029 Spacer (11) in the base plate. Put the connecting rod on the base plate of tooling (B).
6. Put the connecting rod piston pin bearing end in the center of the port assembly of tooling (B). Install pin (6) in the center of the bore for the connecting rod bearings.
7. Install 6V2049 Adapter (9). Put the hole in the adapter in alignment with the hole in the base plate of tooling (B).
8. Install clamp bar (10) and clamp pin (7).
9. Install new piston pin bearing (5) on adapter (9).

NOTE: The old bearing is pushed out by tooling (B) as the new bearing is installed.

10. Put 5P8645 Adapter (8) in position as shown with the taper side down. The piston pin bearing joint must be in alignment with the hole in adapter (9) and the base plate of tooling (B).
11. Put pusher (4) on adapter (8).
12. Use tooling (B) to push the new piston pin bearing into the connecting rod until adapter (8) of tooling (B) makes full contact with the connecting rod surface.
13. Remove the connecting rod and the old piston bearing from tooling (B).
14. Check the piston pin bearing bore diameter after the bearing is installed. The correct dimension is 43.210 ± 0.008 mm ($1.7012 \pm .0003$ in.).

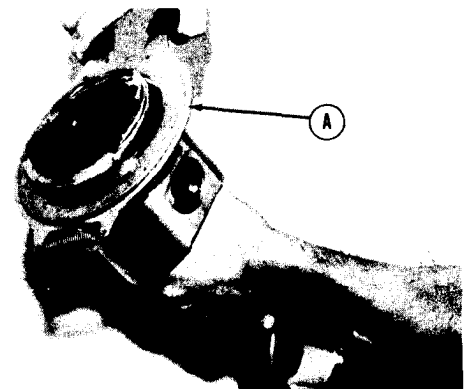

B22185X1

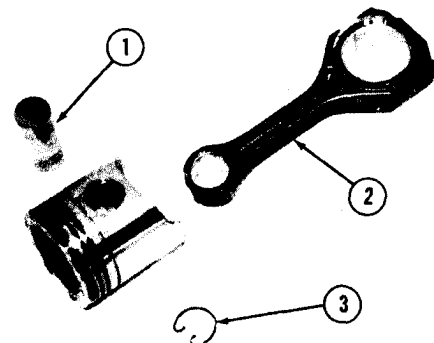

B22189X1

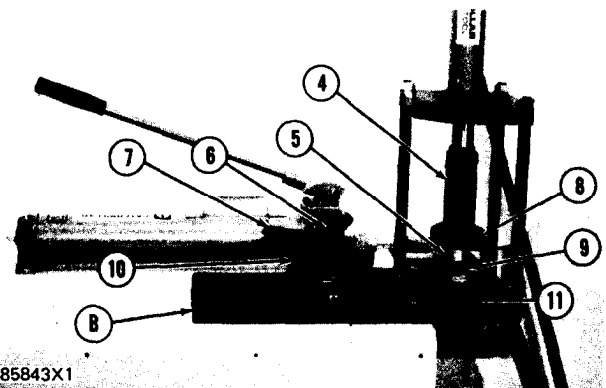

A85843X1

PISTONS

ASSEMBLE PISTONS

1214-16

Tools Needed		A
7S9470	Ring Expander	1

1. Install the connecting rod (4) in the piston with the bearing tab groove (slot) (1) on the same side as the cutout (depression) (3) on the head of the piston.
2. Install piston pin (2) and retaining rings (5) in piston.
3. When old pistons are to be used, clean the piston grooves with an acceptable piston groove cleaning tool.
4. Install the spring for the oil ring. Install the oil ring with tool (A). The gap in the ring must be approximately 180° from the oil ring spring connections.
5. The two compression rings have marks "UP-1" and "UP-2". The rings must be installed with these marks toward the top of the piston with "UP- 1" as the top ring. After installation of all three piston rings, put piston rings in position so gaps in rings are 120° apart.

NOTE: Compression rings that do not have identification can be installed either way.

6. To check the clearance between the piston ring grooves and rings, see SPECIFICATIONS.
7. See SPECIFICATIONS to check the clearance between the ends of the piston rings (end gap).
end by:
a) install pistons

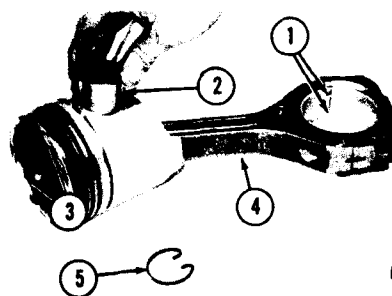

B22190X1

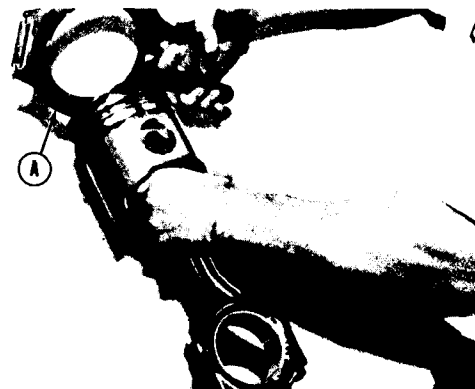

B22186X1

BALANCER SHAFTS**REMOVE BALANCER SHAFTS**

1220-11

start by:

- a) remove timing gear cover
- b) remove oil pump

1. Remove bolts, lock and washer (1) that hold the balancer shafts in the cylinder block.
2. Remove balancer shaft (2) from the cylinder block.

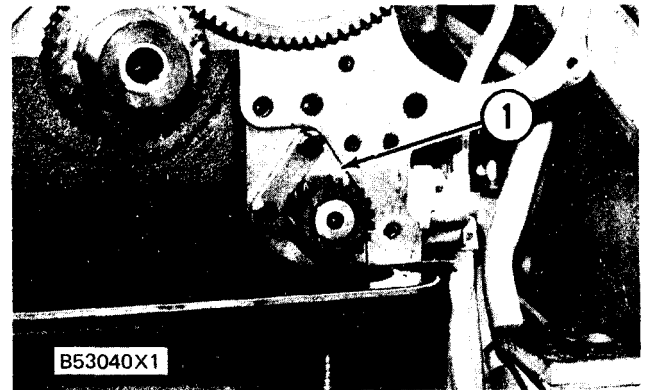
**INSTALL BALANCER SHAFTS**

1220-12

- b. Put the engine on top center compression stroke. See FINDING TOP CENTER COMPRESSION POSITION FOR NO. 1 PISTON in TESTING AND ADJUSTING.
 2. Put clean engine oil on the balancer shaft. Put balancer shaft (1) in position in the cylinder block. Install washer (2), locks and bolts.
 3. Turn both balancer shafts until the flat part on each shaft is away from the oil pan plate. Install two 3/8"-16 NC bolts 1 1/2" long through the oil pan plate and into the holes in the balancer shafts. This will make the shafts so they will not turn. Do not tighten the bolts against the bottom of the holes in the shafts.
 4. Install oil pump. See INSTALL OIL PUMP.
 5. Remove the two 3/8"-16 NC bolts from the balancer shafts. Check to see that the balancer shaft timing is correct. The balancer shaft timing is correct when the holes in the balancer shafts are in alignment with the holes in the oil pan plate, and No. 1 piston is at top center compression position.
- end by:
- a) install timing gear cover
 - b) install oil pan

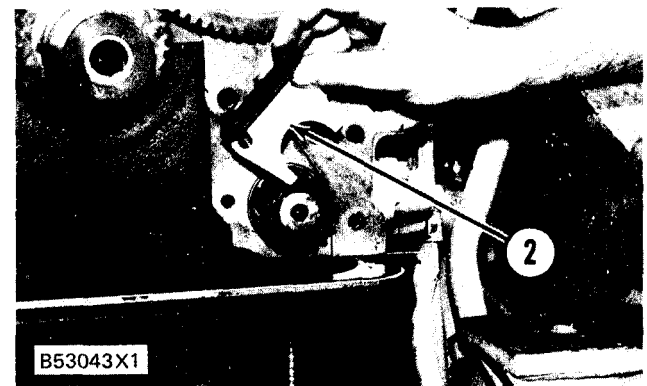
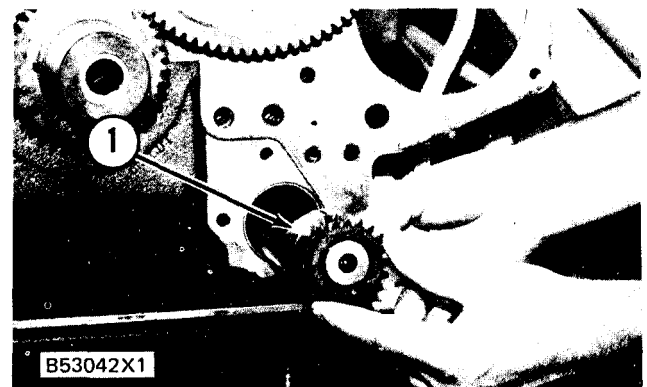
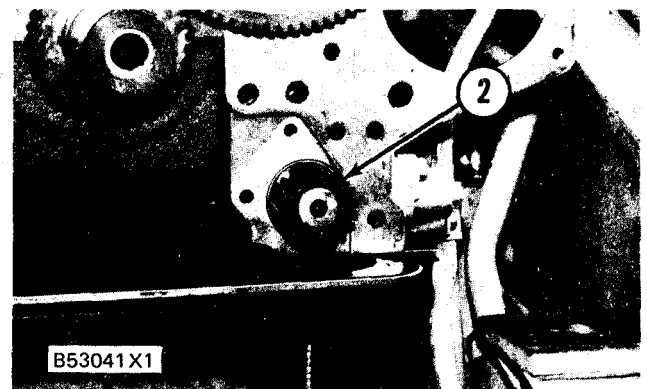

BALANCER SHAFT BEARINGS

REMOVE BALANCER SHAFT BEARINGS

1220-28

Tools Needed		A
8S2241	Camshaft Bearing Tool Group	1
8H684	Ratchet Box Wrench	1

start by:

- a) remove hydraulic pump gear train
- b) remove oil pan
- c) remove oil pump
- d) remove balancer shafts

1. Remove the front bearing for the balancer shaft with tooling (A).
2. Remove the center bearing for the balancer shaft with tooling (A).
3. Remove the rear bearing for the balancer shaft with tooling (A).
4. Do Steps 1, 2 and 3 again for the other balancer shaft bearings.

INSTALL BALANCER SHAFT BEARINGS

1220-28

Tools Needed		A
8S2241	Camshaft Bearing Tool Group	1
8H684	Ratchet Box Wrench	1

1. Install balancer shaft front bearing (1) with tooling (A). Make sure the oil hole in the bearing is in alignment with the oil hole in the cylinder block. The bearing must be 0.8 ± 0.5 mm ($.03 \pm .02$ in.) inside the end of the cylinder block after installation.
2. Use tooling (A) to install the balancer shaft center bearing so the front of the bearing is 290.6 ± 0.5 mm ($11.44 \pm .02$ in.) from the front surface of the cylinder block. Make sure the oil hole in the bearing is in alignment with the oil hole in the cylinder block.
3. Use tooling (A) to install balancer shaft rear bearing (2) so the front of the bearing is 601.0 ± 0.5 mm ($23.66 \pm .02$ in.) from the front surface of the cylinder block. Make sure the oil hole in the bearing is in alignment with the oil hole in the cylinder block.

end by:

- a) install balancer shafts
- b) install oil pump
- c) install oil pan
- d) install hydraulic pump gear train

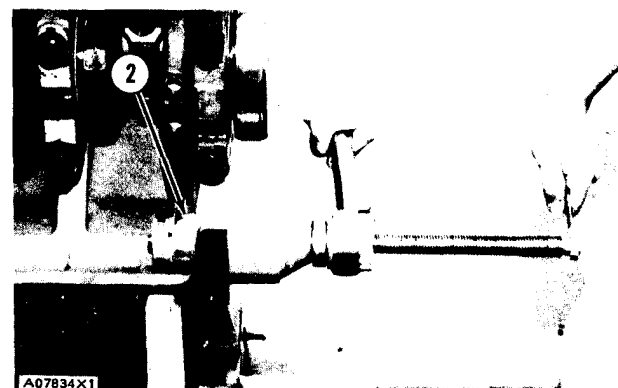
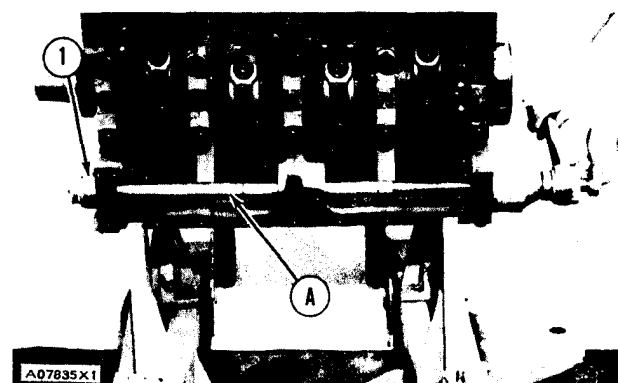
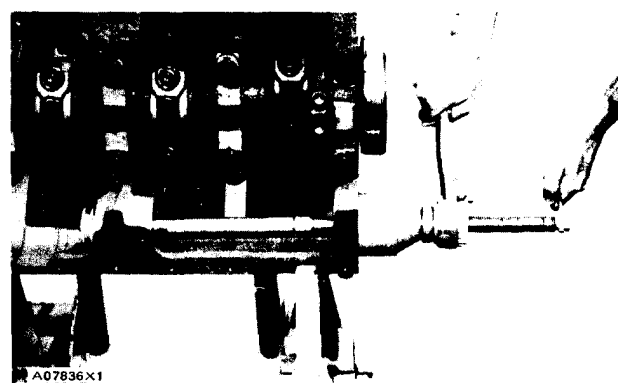
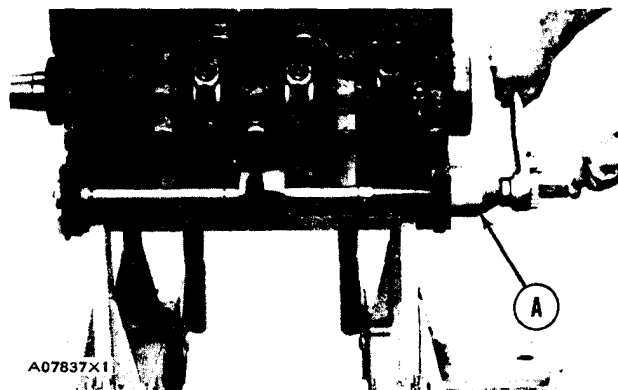

CAMSHAFT

REMOVE CAMSHAFT

1210-11

start by:

- a) remove valve lifters
- b) remove timing gear cover

1. Turn the crankshaft until the "C" mark on the crankshaft gear is in alignment with the "C" mark on the camshaft gear.

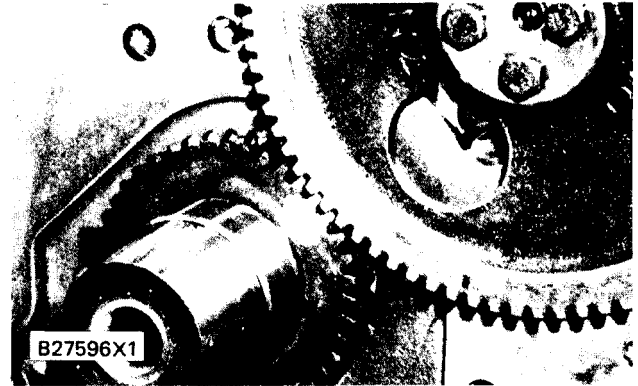

NOTE: To keep the engine timing correct during removal and installation of the camshaft, put a mark on the teeth of the fuel injection pump drive gear and idler gear at location (A). Put a mark on the teeth of the idler gear and camshaft gear at location (B). The engine timing will be correct when the marks at locations (A) and (B) are in alignment and the "C" marks on the crankshaft and camshaft gears are in alignment.

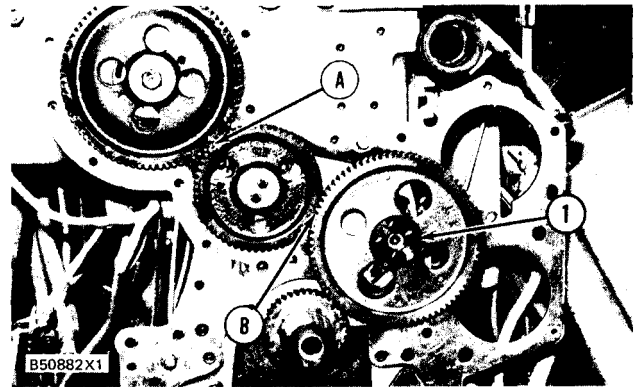

2. Remove bolts (1) that hold the camshaft gear to the camshaft. Remove the camshaft gear.

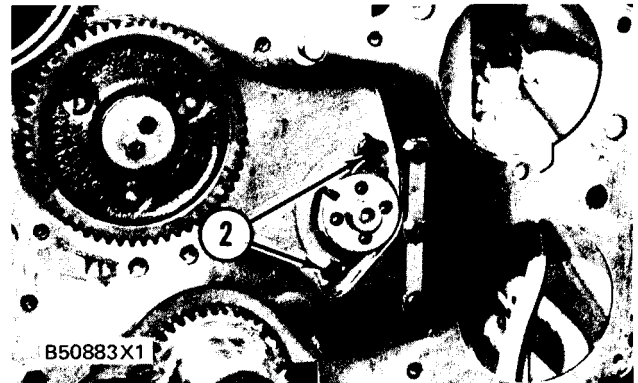

3. Bend the locks away from bolts (2). Remove bolts (2), the lock and thrust plate that hold the camshaft in place.

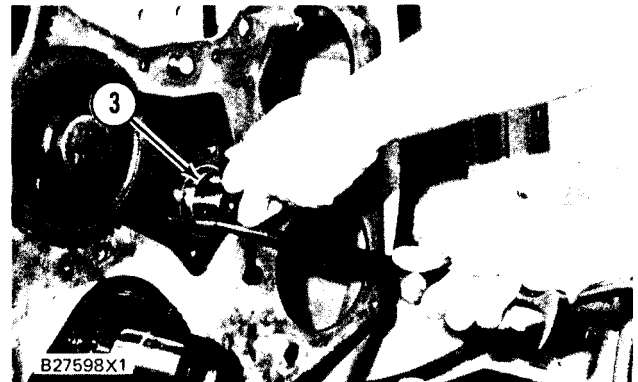

4. Install a 3/8"- 16 NC forged eyebolt in the end of the camshaft. Use the eyebolt and a crow foot bar to carefully remove camshaft (3). Use extra care not to damage the camshaft bearings as the camshaft is removed.

CAMSHAFT

INSTALL CAMSHAFT

1210-12

1. Put clean engine oil on the bearing journals and 2P2506 Thread Lubricant on the cam lobes of the camshaft. Install a 3/8"-16 NC forged eyebolt in the camshaft. Use the eyebolt and a crow foot bar to hold camshaft (1) up during installation so the camshaft bearings will not be damaged.

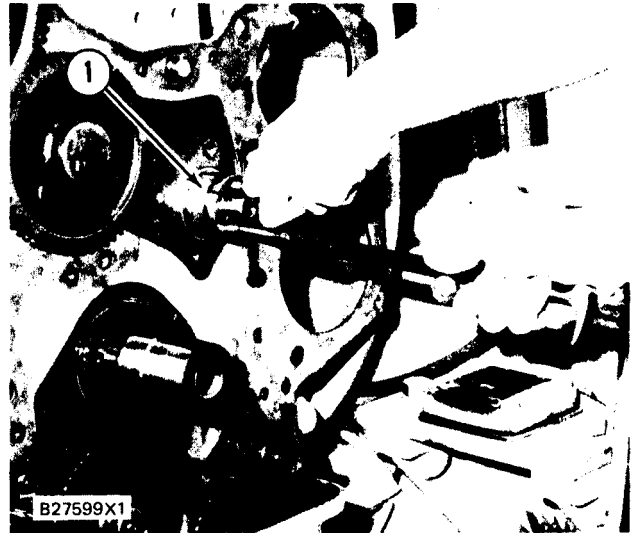

2. Install thrust plate (2), the lock and bolts that hold the camshaft in place. Turn the camshaft so the notch in the end of the camshaft is in the position shown.

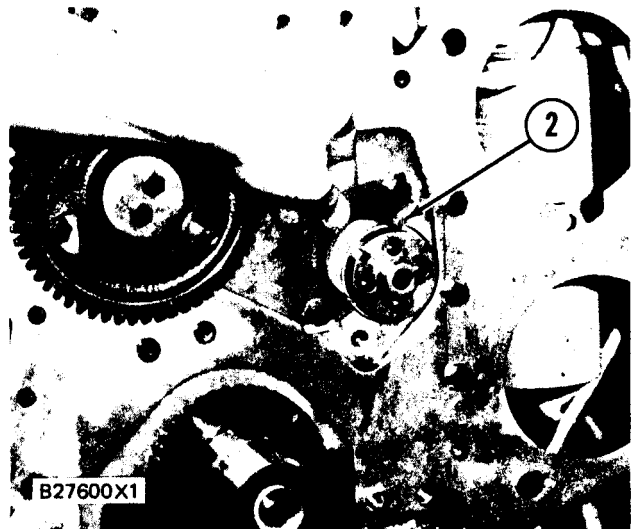

3. Put camshaft gear (3) in position on the camshaft so the "C" mark on the camshaft gear is in alignment with the "C" mark on the crankshaft gear. Install the bolts that hold the camshaft gear in place and tighten to a torque of 55 ± 7 N·m (41 ± 5 lb. ft.).

NOTE: If the bolts can not be installed in the end of the camshaft, remove the camshaft gear. Turn the camshaft as needed and install the camshaft gear again. Check the engine timing to make sure the timing is correct. See INSTALL FUEL INJECTION PUMP HOUSING AND GOVERNOR.

end by:

- a) install timing gear cover
- b) install valve lifters

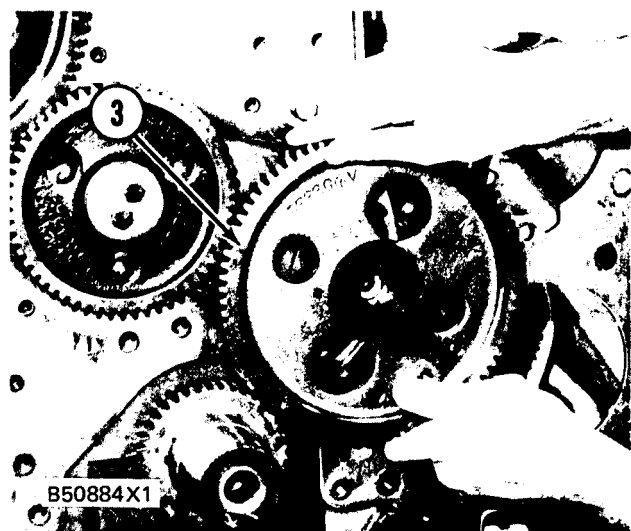

CAMSHAFT BEARINGS

REMOVE CAMSHAFT BEARINGS 1211-11

Tools Needed		A
8S2241	Camshaft Bearing Tool Group	1
8H684	Ratchet Box Wrench	1

start by:

- a) remove camshaft
- b) remove oil pan

1. Remove the camshaft bearings from the cylinder block with tool group (A) and wrench (B). Start with the front bearing.

INSTALL CAMSHAFT BEARINGS 1211-12

Tools Needed		A
8S2241	Camshaft Bearing Tool Group	1
8H684	Ratchet Box Wrench	1

1. Use tooling (A) and (B) to install the camshaft bearings in the cylinder block. Start with the front bearing. The bearings must be installed with the oil hole in each bearing in alignment with the oil holes in the cylinder block and the joint in the bearing toward the center of the block and $8^\circ \pm 5^\circ$ above horizontal. Install the bearings to the dimensions shown in the illustration at the bottom of the page.

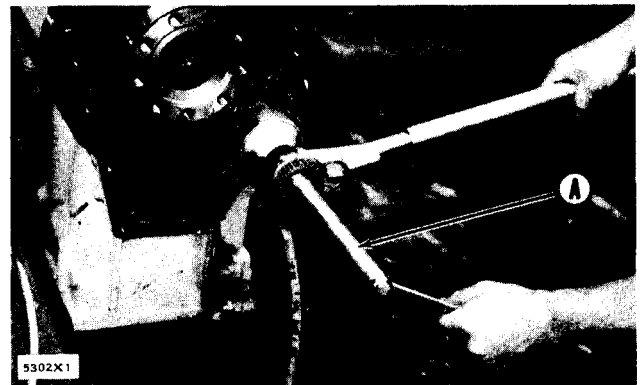
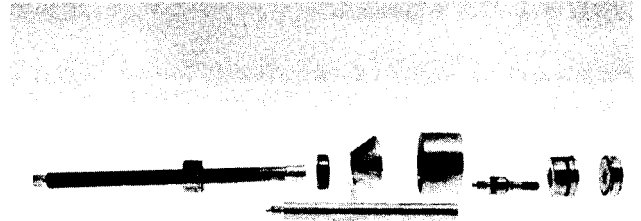

TYPICAL EXAMPLE

end by:

- a) install oil pan
- b) install camshaft
- c) install hydraulic pump gear train

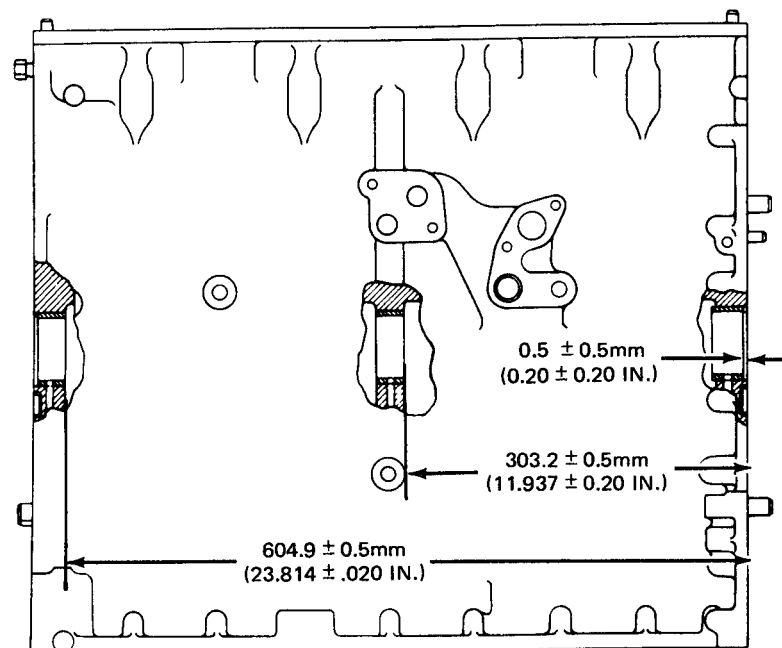

CYLINDER LINERS

REMOVE CYLINDER LINERS 1216-11

Tools Needed		A
5P8665	Cylinder Liner Puller	1

start by:

a) remove pistons

1. Remove the coolant from the cylinder block.
2. Put covers on journals of crankshaft for protection from dirt or water.
3. Remove cylinder liners (1) with tool (A).

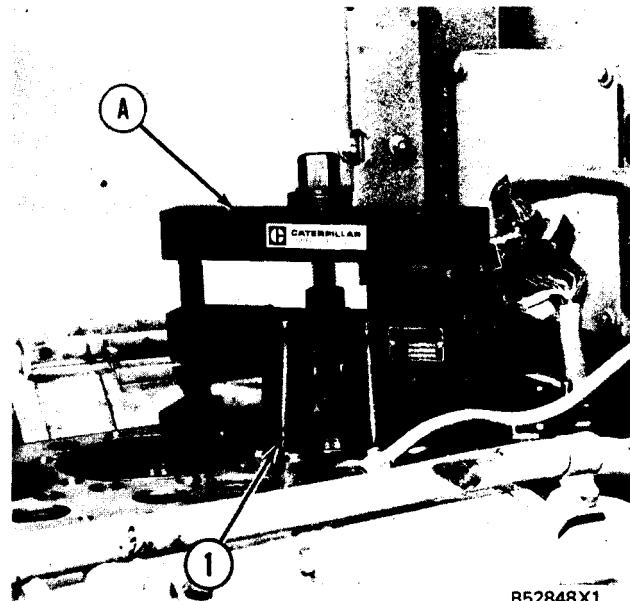

INSTALL CYLINDER LINERS 1216-12

Tools Needed		A	B	C
2P8260	Cylinder Liner Installation Tool 1			
1P5510	Liner Projection Tool			1
8B7548	Puller Crossbar		1	
1P2394	Adapter Plate		1	
3H465	Plate		2	
S1589	Bolt, 5/8"-11 NC(1.75 in.) long		10	
1S379	Washer (copper)		10	
1D4595	Bolts		2	
2S736	Washers		2	

1. Clean the cylinder liners (3) and the liner bores in the cylinder block.
2. Install the cylinder liners in the block without the O-ring seals or filler bands.
3. Check the cylinder liner projection as follows:
 - a) Install the S1589 Bolts (2) and 1S379 Washers of tooling (B) on the cylinder block next to each liner. Tighten the bolts evenly, in four steps: 14 N·m (10 lb.ft.), 35 N·m (25 lb. ft.), 70 N·m (50 lb.ft.) and 95 N·m (70 lb. ft.).
 - b) Put adapter plate on top of the liner and install the remainder of tooling (B). Tighten the 1D4595 Bolts (1) evenly in four steps: 7 N·m (5 lb.ft.), 20 N·m (15 lb.ft.), 35 N·m (25 lb.ft.) and 70 N·m (50 lb.ft.).

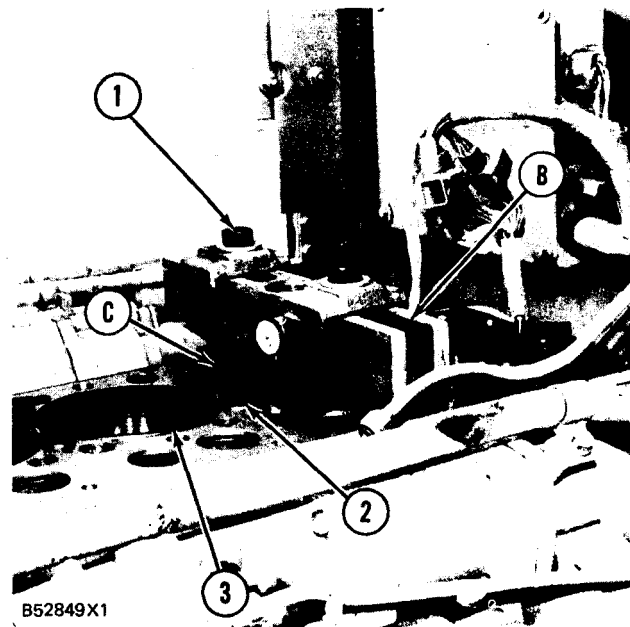

CYLINDER LINERS

- c) Check to be sure the distance from the bottom edge of the crossbar to the top of the cylinder block is the same on both sides of the liner.
- d) Check the cylinder liner projection with tool group (C) at four locations around the liner.
- e) Liner projection must be 0.033 to 0.175 mm (.0013 to .0069 in.). Measurements on the same liner must not be different by more than 0.05 mm (.002 in.). Average measurements between liners next to each other must not be different by more than 0.05 mm (.002 in.).

NOTE: If the liner is turned in the bore, it can make a difference in the liner projection.

4. If the liner projection is not 0.033 to 0.175 mm (.0013 to .0069 in.), check the thickness of the following parts: spacer plate, spacer plate gasket and cylinder liner flange. The thickness of the spacer plate must be 9.970 ± 0.025 mm (.3925 \pm .0010 in.). The thickness of the spacer plate gasket must be 0.208 ± 0.025 mm (.0082 \pm .0010 in.). The thickness of the cylinder liner flange must be 10.282 ± 0.020 mm (.4048 \pm .0008 in.).

NOTE: If the liner projection changes from point to point around the liner, turn the liner to a new position in the bore. If the liner projection is still not to specifications, move the liner to a different bore.

5. When the cylinder projection is correct, put a mark on the liner and block so the liner can be installed in the same position from which it was removed.

NOTE: Cylinder liner projection can be adjusted by the removal of material from (machining) the contact face of the cylinder block with the use of the 8S3140 Cylinder Block Counterboring Tool Arrangement. Machine to a minimum depth of 0.76 mm (.030 in.) and to a maximum depth of 1.14 mm (.045 in.). The instructions for the use of the tool group are in Special Instruction Form No. FM055228. Shims are available for the adjustment of the liner projection. See CYLINDER LINER PROJECTION in TESTING AND ADJUSTING for the shim thickness and part number.

6. Remove tooling (B) and (C). Remove the liner.
7. Put liquid soap on bottom liner bore in block, on grooves in lower liner and on O-ring seals (4). Install O-ring seals on the liner.
8. Put filler band (5) in clean SAE 30 oil for a moment and install on liner. Install cylinder liner immediately in the cylinder block (before expansion of filler band).

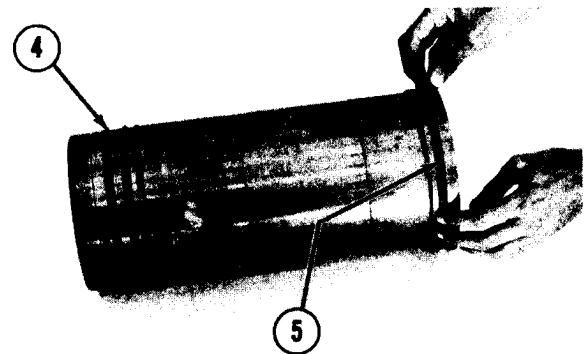

A11460X2

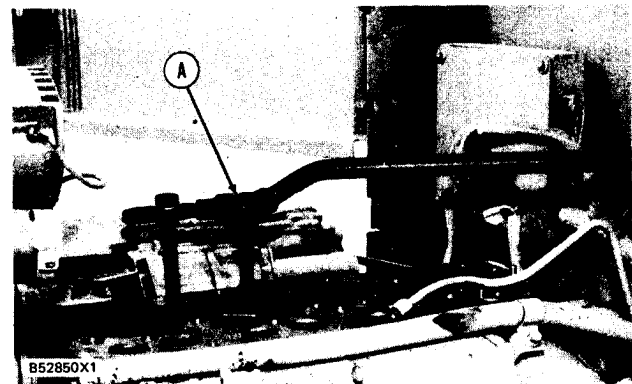

9. Make sure the mark on liner is in alignment with the mark on the block. Use tooling (A) to push the liner into position.
10. Do Steps 5 through 9 for the remainder of the cylinder liners.
end by:
 - a) install pistons

CONNECTING ROD BEARINGS

REMOVE AND INSTALL CONNECTING ROD BEARINGS 1219-10

Tools Needed	A
Plastigage	-

start by:

- a) remove oil pump
- b) remove oil pan plate

1. Turn the crankshaft until two pistons are at the bottom center. Remove connecting rod caps (1) from the two connecting rods. Remove the lower half of the rod bearing from the rod bearing cap.
2. Push the connecting rods away from the crankshaft. Remove the upper half of the rod bearing from the connecting rod.

NOTE: Install the connecting rod bearings dry when the clearance checks are made. Put clean engine oil on the connecting rod bearings for final assembly.

3. Install the upper half of the rod bearing in the connecting rod.
4. Install the lower half of the rod bearing in the connecting rod cap.

NOTE: Be sure the tabs in the back of the connecting rod bearings are in the tab grooves of the connecting rod and cap.

5. Use Plastigage (A) to check the connecting rod bearing clearance.
6. Put Plastigage (A) on the connecting rod bearing.
7. Put clean engine oil on the threads of the rod bolts and seat surfaces of the nuts.

CAUTION

When connecting rod caps are installed, make sure the number on the side of the cap is next to and respective with the number on the side of the connecting rod.

NOTE: Do not turn the crankshaft when Plastigage (A) is in position.

CAUTION

Do not use an impact wrench to tighten the nuts the additional 90°.

8. Install connecting rod cap (1). Install the nuts. Tighten the nuts to a torque of 40 ± 4 N·m (30 ± 3 lb.ft.). put a mark on each nut and the end of each bolt. Tighten the nuts 90° more. Remove the connecting rod caps. Remove Plasti-

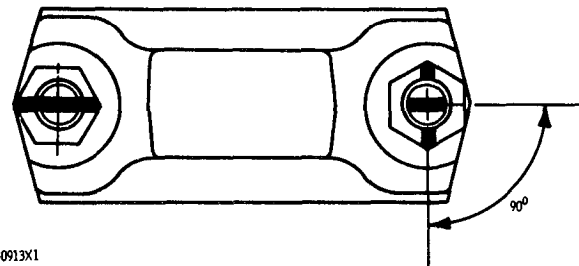
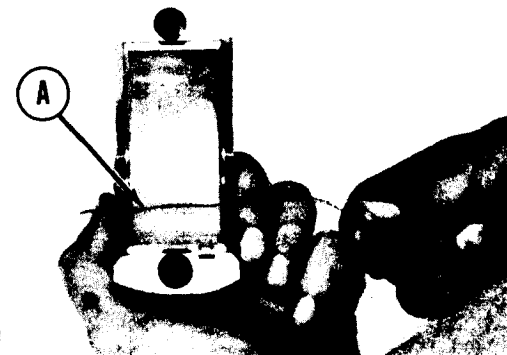

gage (A) and measure the width of the Plastigage. The connecting rod clearance must be 0.076 to 0.168 mm (.0030 to .0066 in.) for new bearings. The maximum clearance with used bearings is 0.25 mm (.010 in.).

9. Install the connecting rod caps and tighten the nuts as in Step 8.
10. Do Steps 1 through 9 for the remainder of the connecting rod bearings.
end by:
 - a) install oil pan plate
 - b) install oil pump

CRANKSHAFT MAIN BEARINGS

REMOVE AND INSTALL CRANKSHAFT MAIN BEARINGS 1219-10

Tools Needed	A	B	C
2P5518 Main Bearing Removal Tool	1		
Plastigage			
8S2328 Dial Test Indicator Group			1

start by:

- a) remove oil pump
- b) remove oil pan plate
1. Remove the No. 1, 3 and 5 main bearing caps (1). Remove the crankshaft thrust bearing from the No. 5 main bearing.
2. Remove the lower half of the main bearing from the main bearing caps.

CAUTION

If the crankshaft is turned in the wrong direction, the tab on bearing will be pushed between the crankshaft and bearing area in block which can cause damage to the block or crankshaft.

3. Install tool (A) in the oil hole in the crankshaft journal and remove the upper half of the main bearing as the crankshaft is turned and the main bearing is moved out of the cylinder block.

NOTE: Install the main bearings dry when the clearance checks are made. Put clean engine oil on the main bearings for final assembly.

CAUTION

Make sure the upper and lower halves of the main bearings are installed so the bearing tabs fit into the notch in cylinder block and the main bearing caps.

4. Install new lower half of main bearings (2) in the main bearing caps. Use tool (A) and install the upper half of the main bearings in the cylinder block.
5. Put clean oil on the thrust bearing and install a new thrust bearing for the No. 5 main bearing. Install the thrust bearing with the identification "BLOCK SIDE" toward the cylinder block and the tabs on the thrust bearings in the machined area in the cylinder block. The tabs will not let the thrust bearing be installed backward.

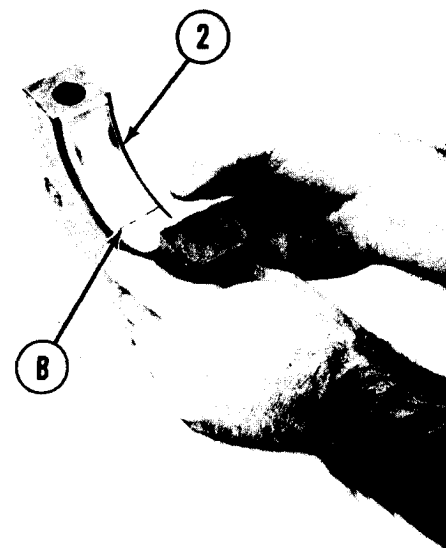

NOTE: When the bearing clearance is checked and the engine is in a vertical position, such as in the vehicle, the crankshaft will have to be lifted up and held against the upper halves of the main bearings to get a correct measurement with the Plastigage. The Plastigage will not hold the weight of the crankshaft and give a correct indication. If the engine is in a horizontal position, it is not necessary to hold the crankshaft up. Do not turn the crankshaft when the Plastigage is in position to check clearances.

6. Check the main bearing clearances with Plastigage (B) as follows:
 - a) Put a piece of Plastigage (B) on the surface of the lower half of the main bearing.

CRANKSHAFT MAIN BEARINGS

CAUTION

Make sure the part number on the main bearing cap is toward the front of the engine and the number on the main bearing cap is the same as the number on the cylinder block on the left side of each main bearing cap.

NOTE: Do not turn the crankshaft when Plastigage (B) is in position.

- b) Install main bearing caps (1) for No. 1 and 3 and 5 main bearings. Put clean engine oil on the bolt threads and the face of the washers and install the bolts. Tighten the bolts to a torque of 40 ± 4 N·m (30 ± 3 lb. ft.).

CAUTION

Do not use an impact wrench to tighten the bolts the additional 90° .

- c) Put a mark on each bolt and main bearing cap, then tighten the bolts 90° more.
- d) Remove the main bearing caps for No. 1, 3 and 5 main bearings. Remove Plastigage (B) and measure the width of the Plastigage. The main bearing clearance must be 0.076 to 0.165 mm (.0030 to .0065 in.). Maximum permissible clearance with used bearings is 0.25 mm (.010 in.).

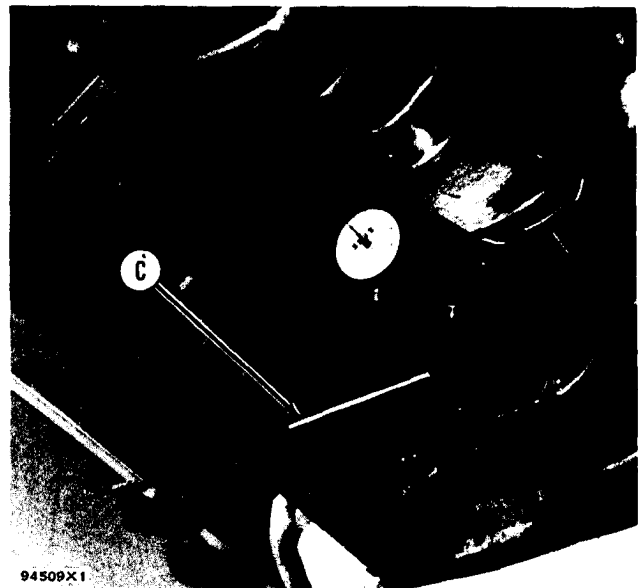
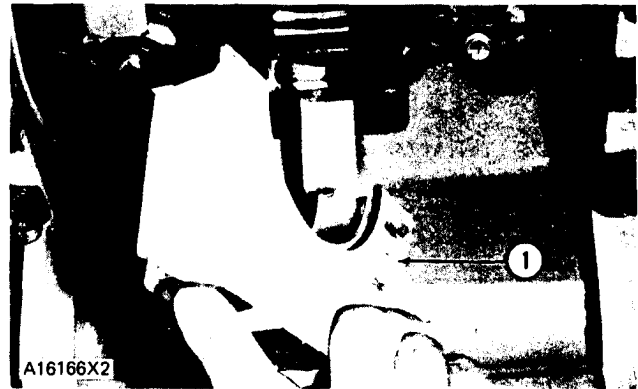

TYPICAL EXAMPLE

7. Install main bearing caps (1) and tighten the bolts as in Steps 6b and 6c.
8. Remove No. 2 and 4 main bearing caps. Do Steps 2, 3, 4, 6 and 7 for the No. 2 and 4 main bearings.
9. Check the crankshaft end play with tooling (C). The end play is controlled by the thrust bearings on the No. 5 main bearing. End play with new bearings is 0.064 to 0.368 mm (.0025 to .0145 in.). The maximum permissible end play with used bearings is 0.64 mm (.025 in.). end by:
 - a) install oil pan plate
 - b) install oil pump

CRANKSHAFT AND GEAR

REMOVE CRANKSHAFT AND GEAR

1202 & 1204-11

Tools Needed		A
8B7548	Puller Assembly	1
8H684	Ratchet Box Wrench	1
8B7560	Step Plate	1
8B7551	Bearing Puller Attachment	1

start by:

- a) remove hydraulic pump gear train
- b) remove timing gear cover
- c) remove pistons
1. Install a 3/4" - 16 NC bolt in the gear end of the crankshaft. Install two 5/8"- 18 NF bolts in the flywheel end of the crankshaft. Fasten a hoist to the crankshaft.
2. Remove main bearing caps (1).
3. Remove the crankshaft from the cylinder block. Weight of the crankshaft is approximately 65 kg (145 lb.).
4. Remove main bearings (2) from the block and from the caps. Remove the thrust bearings.
5. Use tooling (A) to remove gear (3) from the crankshaft.

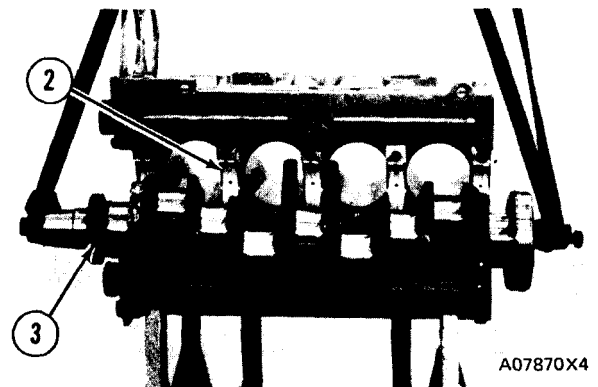
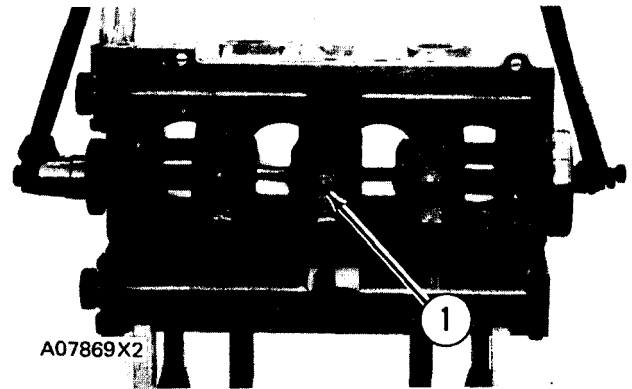

INSTALL CRANKSHAFT AND GEAR

1201 & 1204-12

Tools Needed		A	B
Plastigage		.	
8S2328	Dial Test Indicator Group		1

1. Heat the crankshaft gear to a maximum temperature of 315°C(600°F). Install the gear on the crankshaft with the "C" mark on the gear toward the pulley end of the crankshaft.
2. Clean the surfaces on the cylinder block for the main bearings. Install the upper halves of the main bearings in the block. Put clean engine oil on the bearings.
3. Turn the camshaft so the "C" mark on the camshaft gear will be toward the "C" mark on the crankshaft gear when the crankshaft is installed. Put the crankshaft in position in the cylinder block with a hoist. Make sure the timing marks on the camshaft gear and crankshaft gear are in alignment as shown.
4. Clean the Nos. 1 and 5 main bearing caps. Install new bearings in the caps. Put clean engine oil on the bearings. Temporarily install the caps to hold the crankshaft in place.

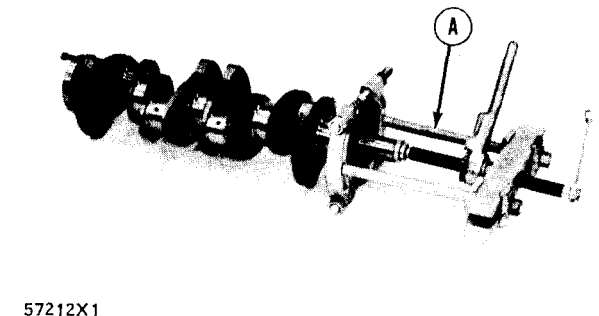

TYPICAL EXAMPLE

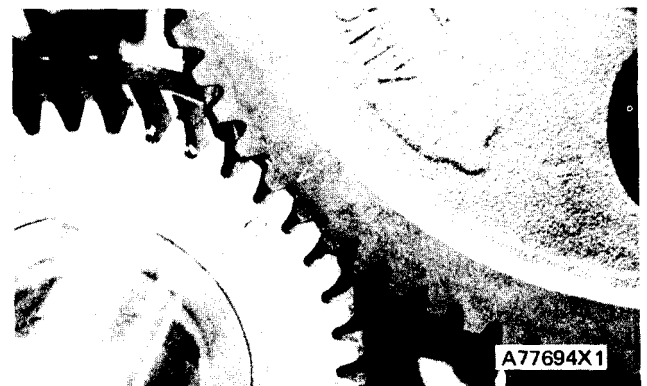

TYPICAL EXAMPLE

CRANKSHAFT AND GEAR

CAUTION

Make sure part number on cap is toward front of engine, and number on bottom of cap is the same as number on block when caps are installed.

5. Clean the Nos. 2, 3 and 4 main bearing caps. Install new bearings in the caps. Put clean engine oil on the bearings, bolts, threads and surfaces of the washers for the caps.
6. Check the bearing clearance with Plastigage (A). Install the caps and tighten the bolts to a torque of 41 ± 4 N·m (30 ± 3 lb.ft.). Put a mark on each bolt head and the bearing caps. Tighten the bolts 90° more. Remove the bearing caps and measure the width of the Plastigage. The main bearing clearance (Plastigage width) with new bearings must be 0.076 to 0.165 mm (.0030 to .0065 in.). The maximum permissible clearance with used bearings is 0.25 mm (.010 in.).
7. Put the caps in position on the engine and install the washers and bolts. Tighten the bolts to a torque of 41 ± 4 N·m (30 ± 3 lb.ft.). Put a mark on each bolt head and the bearing caps. Tighten the bolts 90° more.
8. Remove the Nos. 1 and 5 main bearing caps. Follow the procedure in Steps 5 and 6 and check the main bearing clearance for the Nos. 1 and 5 main bearings.
9. Follow the procedure in Step 7 and install the No. 1 main bearing cap.
10. Put clean engine oil on thrust bearings (1). Install the bearings with the steel back against the cylinder block. Install the No. 5 main bearing cap. Tighten the bolts for the cap with the procedure in Step 7.
11. Check the crankshaft end play with tool group (B). The end play is controlled by the thrust bearings on the No. 5 main. The end play with new bearings must be 0.064 to 0.368 mm (.0025 to .0145 in.). The maximum permissible end play with used bearings is 0.64 mm (.025 in.).

NOTE: If a replacement has been made for any of the timing gears, it will be necessary to check the engine timing to make sure it is correct. See INSTALL FUEL INJECTION PUMP HOUSING AND GOVERNOR.

end by:

- a) install pistons
- b) install timing gear cover
- c) install hydraulic pump gear train

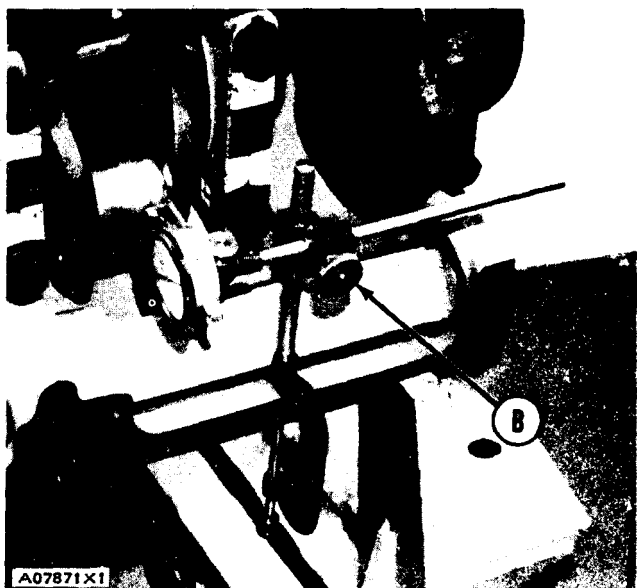
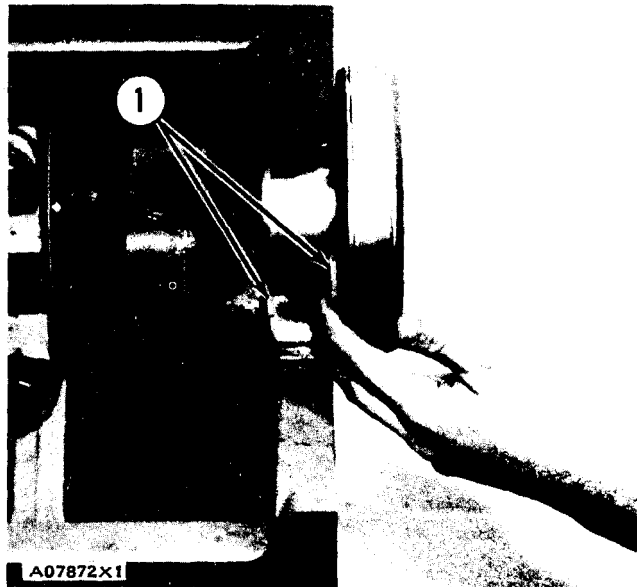
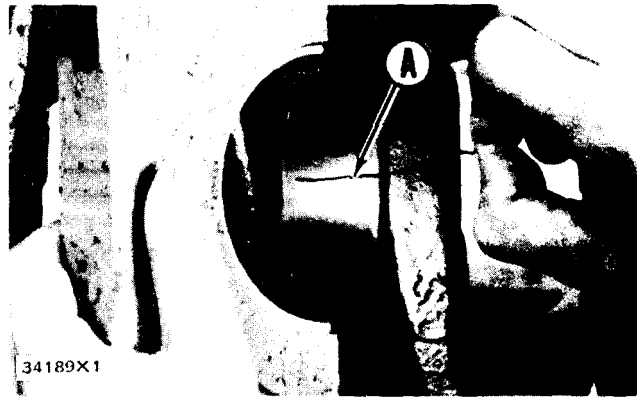

PISTON COOLING ORIFICES

REMOVE AND INSTALL PISTON COOLING ORIFICES 1307-10

Tools Needed		A
FT1542	Orifice Driver	1

start by:

a) remove crankshaft and gear

NOTE: The piston cooling orifices are installed in the No. 2 and 4 main bearing bosses in the cylinder block.

1. Use a soft punch to remove the orifices from the cylinder block.
2. Use tool (A) to install the orifices in main bearing bosses No. 2 and 4 until they are against the counterbore. Be sure the orifices are open after they are installed.

end by:

a) install crankshaft and gear

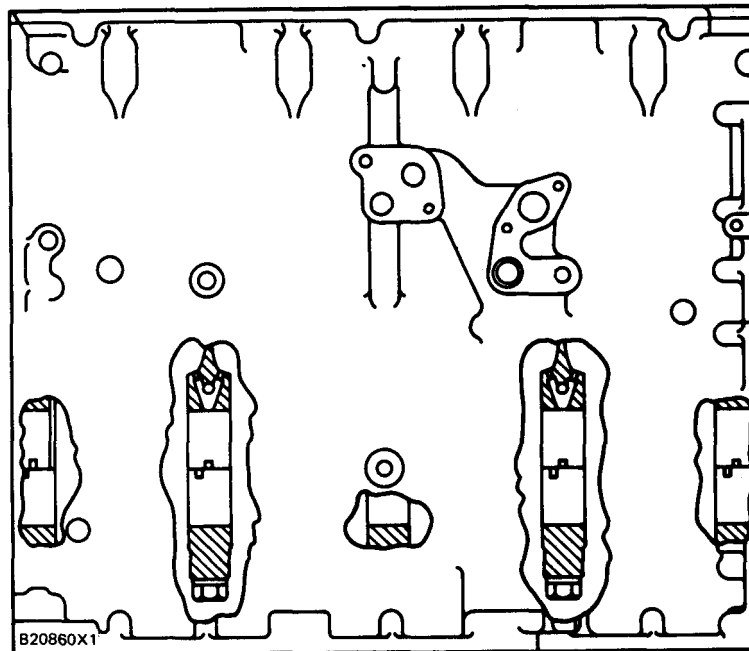

ENGINE

REMOVE ENGINE

1000-11

Tools Needed		A
6V3145	Load Leveler	1

start by:

- a) remove radiator and guard

WARNING

If NBC exposure is suspected, all air filter media should be handled by personnel wearing protective equipment. Consult your unit NBC Officer or NBC NCO for appropriate handling or disposal instructions.

- b) remove air cleaner
- c) remove muffler
- d) remove rear drive shaft

1. Remove nuts (2) and disconnect the disconnect switch (1) from the frame.

WARNING

Release the pressure in the air reservoir before any lines are disconnected.

NOTE: Models 950BNS and 950BS shown. Hose locations for Models 950BNSCE and 950BSCE are slightly different.

2. Disconnect air lines (3) from the engine.
3. Put identification on wires (4), (5) and (6). Disconnect wires (4), (5) and (6) from the starter and the solenoid.
4. For Models 950BNS and 950BS, disconnect control cable (7) from governor. Remove screws and bracket (8) from engine.
5. For Models 950BNSCE and 950BSCE:
 - a) Remove screws, cover (24) and gasket.
 - b) Disconnect control cable (25) from governor.
 - c) Remove lever (26), screws, and housing (27) from engine.

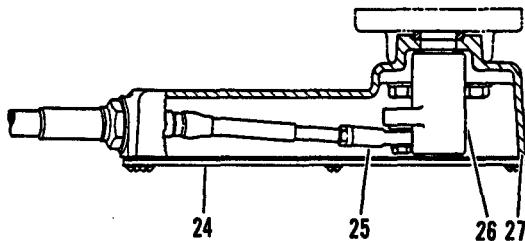

Models 950BNSCE and 950BSCE

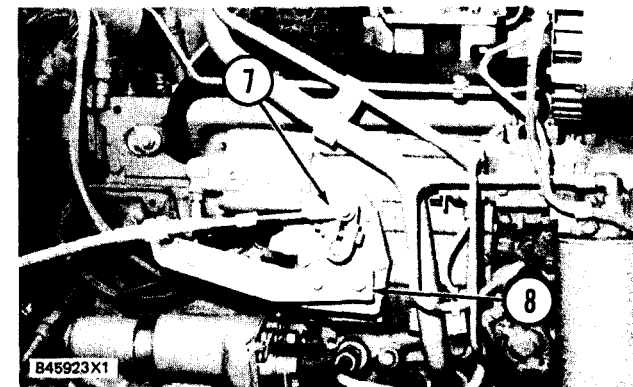
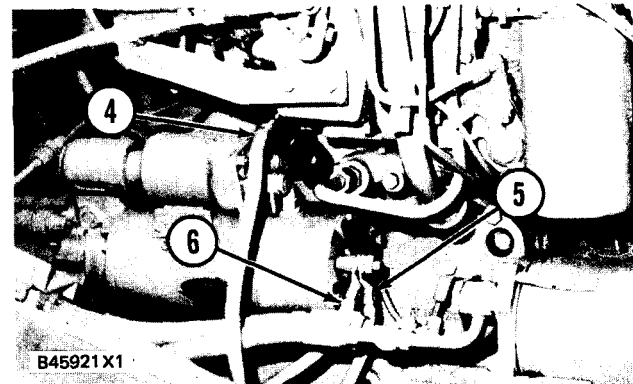
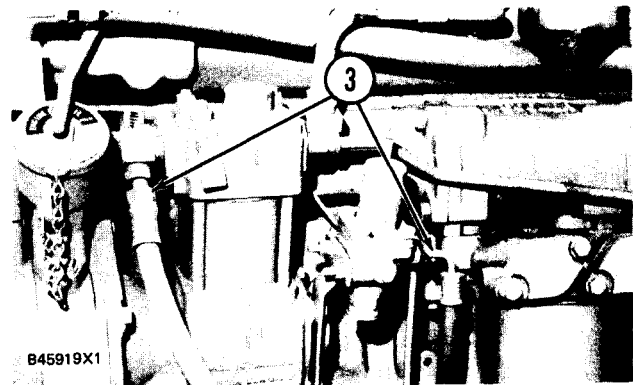
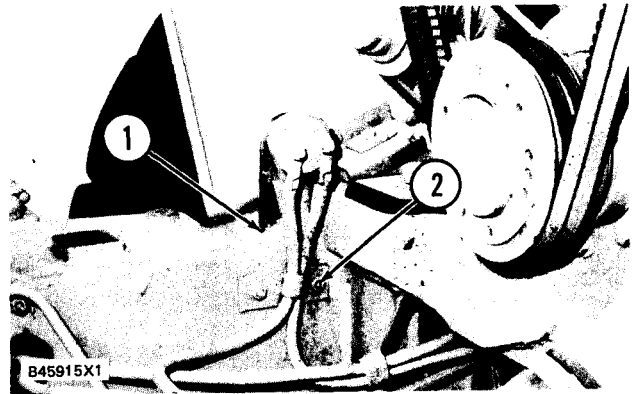

Models 950BNS and 950BS

ENGINE

6. Put identification on wire harness (9) and disconnect them at the rear of the machine.

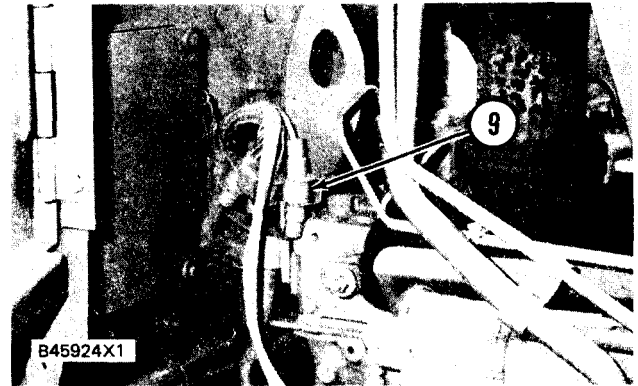

7. Disconnect fuel lines (10) from the fuel injection pump housing and the rear of the engine.

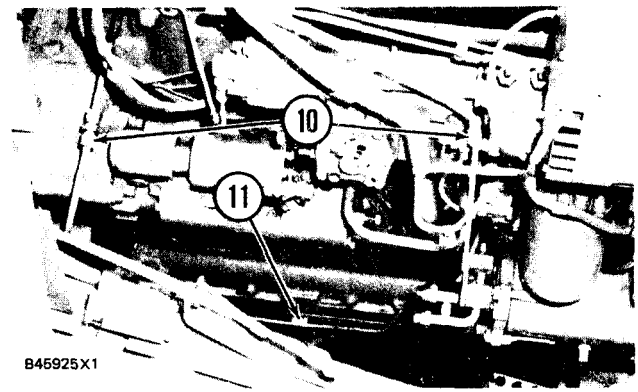

9. Put identification on the wire assembly (12) and disconnect them from the sending unit at the torque converter housing.

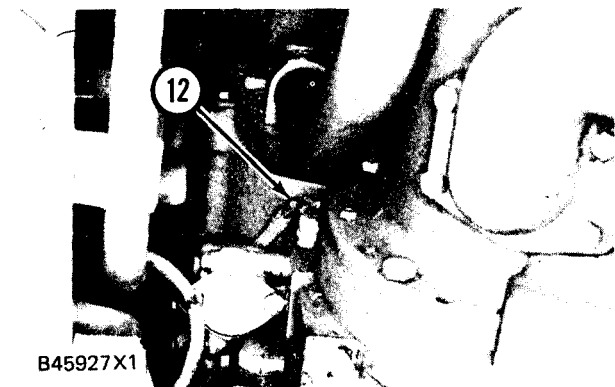

10. Disconnect the clip that holds wire assembly (12) on top of the relief valve.

11. Remove the bolts and lower tube assembly (13) that connects the oil cooler to the torque converter.

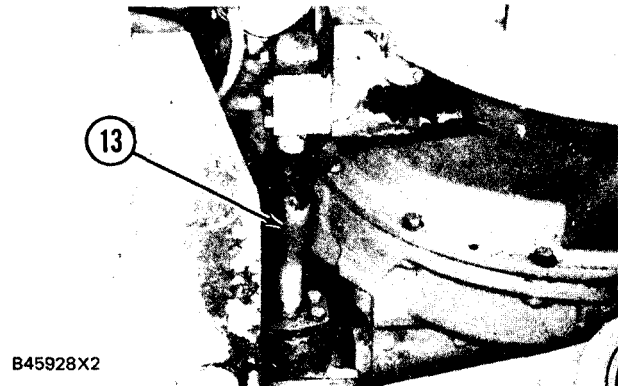

ENGINE

12. Remove the bolts and upper tube assembly (14) that connects the oil cooler to the torque converter.

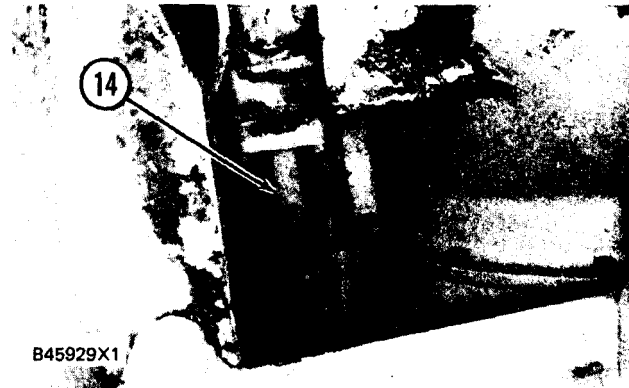

13. Remove the bolts and nuts and remove muffler brackets (15) and (16) from the engine.

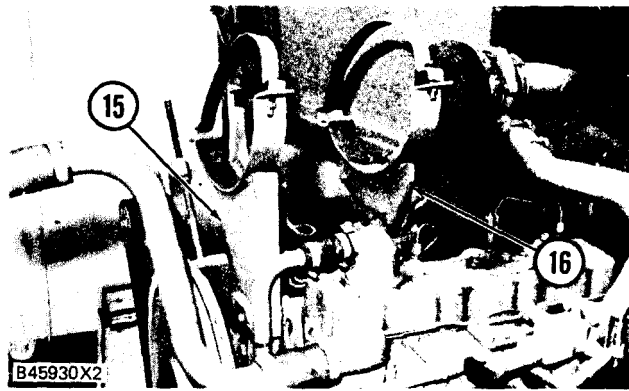

14. Loosen clamp (18) and disconnect the clip from the engine. Remove breather (17) from the engine.

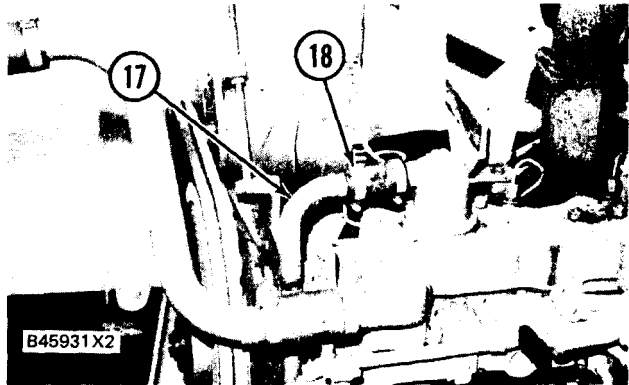

15. Install block (19) and an approved floor jack (20) as a support for the transmission so it will not fall when the engine is removed.



ENGINE

16. Fasten tool (A) to engine (21) as shown.

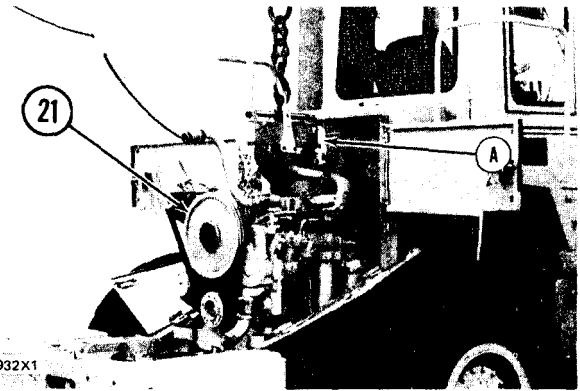

17. Remove bolts (22) and (23) from the front engine mounts.

18. Remove the bolts that hold the transmission case to the flywheel housing.

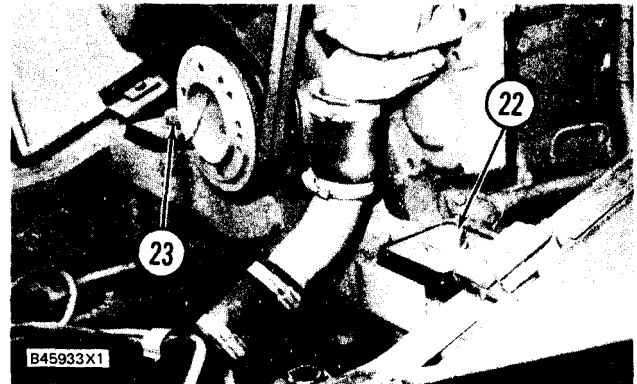

19. Lift up on the engine a small amount and remove it. The weight of the engine is 838 kg (1850 lb.).

NOTE: If necessary, use forcing screws to make a separation of the transmission case and the flywheel housing.

ENGINE

INSTALL ENGINE

1000-12

	Tools Needed	A
6V3145	Load Leveler	1

1. Fasten a hoist and tooling (A) to the engine. Put engine (1) in position and make an alignment of the flywheel and the torque converter. For easier installation keep the engine level.

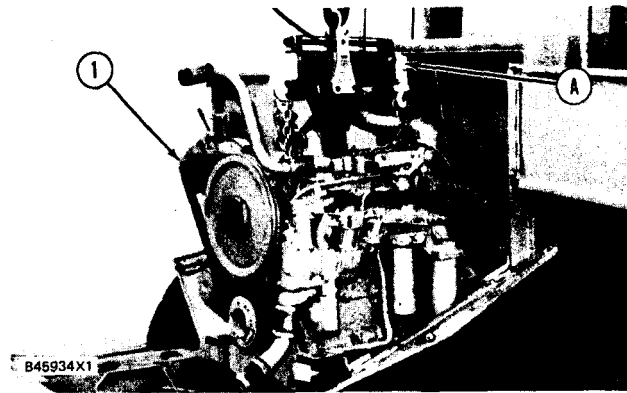

NOTE: Make sure the O-ring seal is in position on the transmission case.

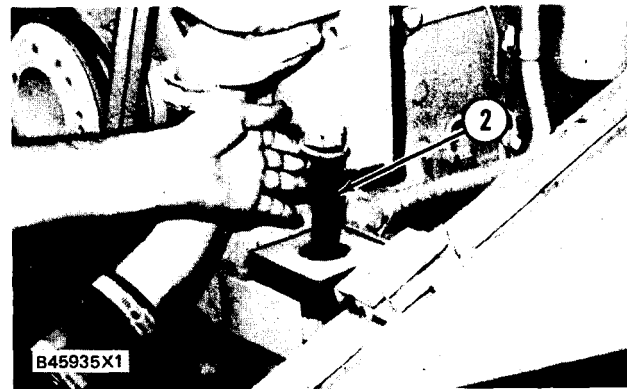

2. Install the bolts that hold the flywheel housing to the transmission.

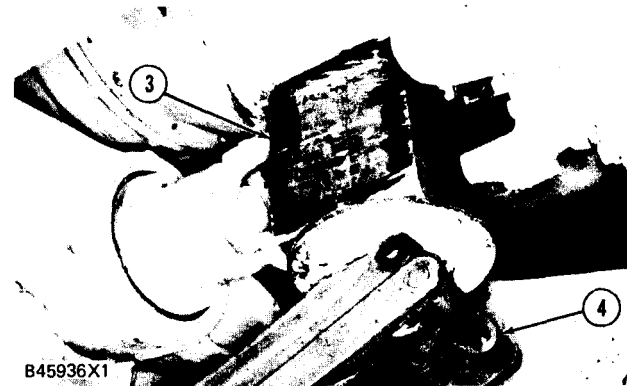

3. Install front mounting bolts (2).

4. Remove block (3) and approved floor jack (4) from the under the transmission housing.

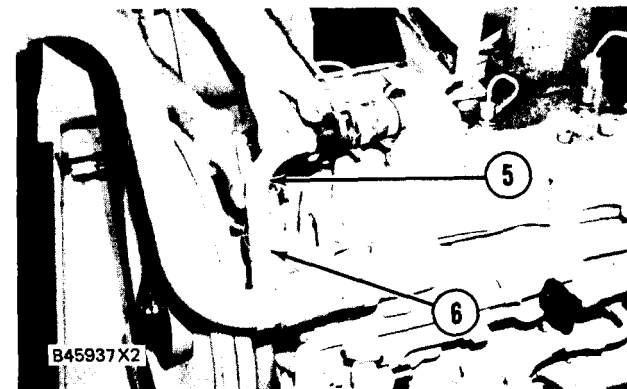

5. Install the breather tube (5) and connect clip (6) to the engine.

ENGINE

6. Install muffler brackets (7) to the engine.

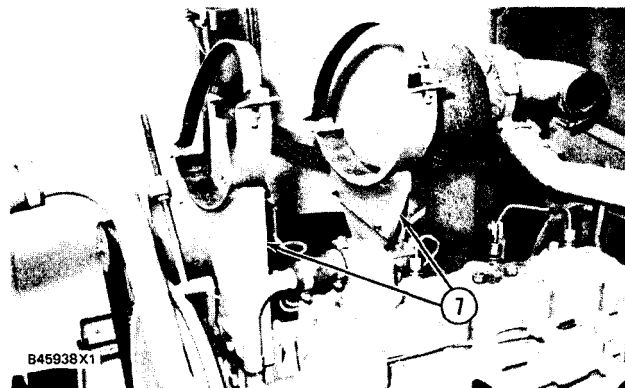

7. Install upper tube assembly (8) to the oil cooler and torque converter.

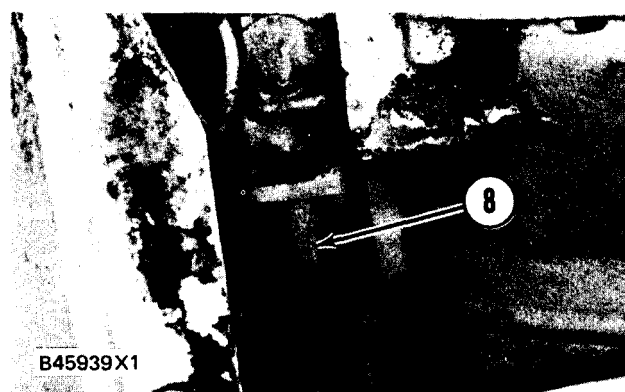

8. Install lower tube assembly (9) to the oil cooler and torque converter.

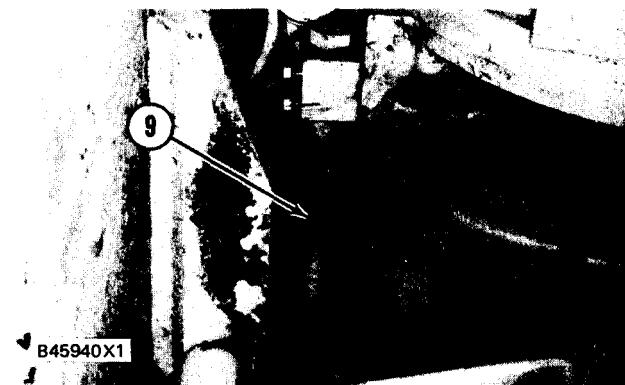

9. Connect wire assembly (10) to the sending unit on the torque converter and install the bolt that holds the wire clip to the top of the relief valve.

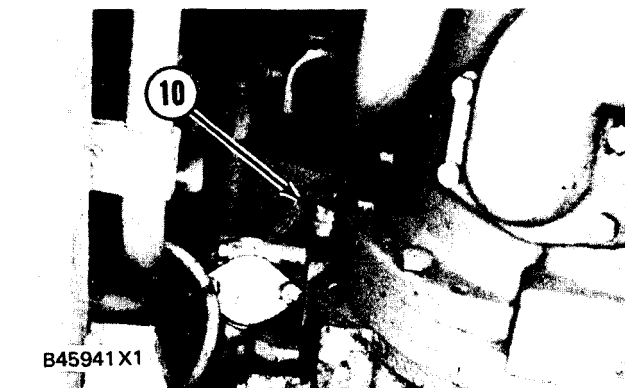

ENGINE

ENGINE

- 10. Connect fuel lines (11) to the fuel injection pump housing and at the rear of the engine.

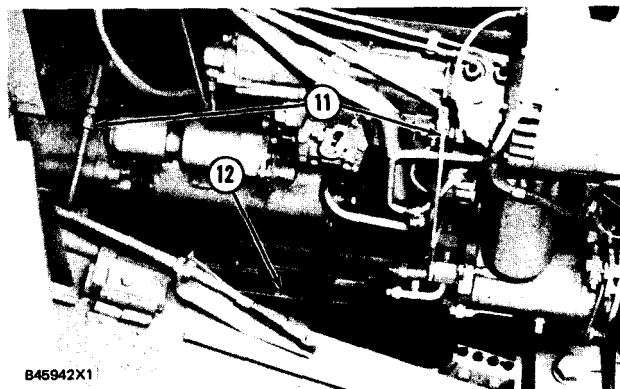

B45942X1

- 11. Connect fuel line clips (12) to the oil pan.
- 12. Connect wire harnesses (13), (14) and (15) at the rear of the engine.

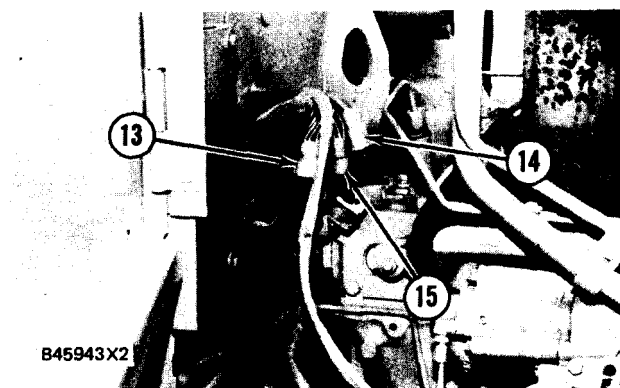

B45943X2

- 13. For Models 950BNS and 950BS:
 - a) Connect bracket (17) to governor.
 - b) Connect cable assembly (16) to governor control lever.

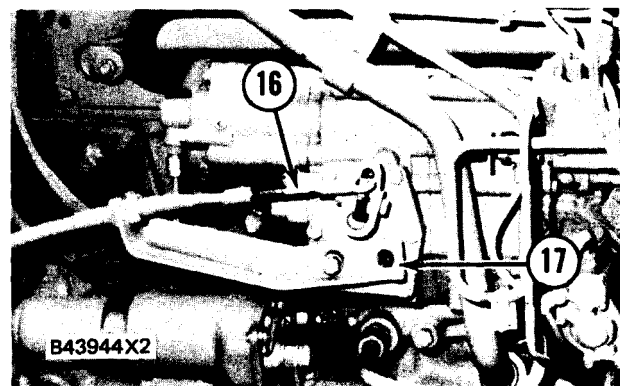

B43944X2

Models 950BNS and 950BS

- 14. For Models 950BNSCE and 950BSCE:
 - a) Install housing (22) and two screws.
 - b) Turn governor shaft clockwise to off position. Install lever (23) and bushings with lever approximately 35° forward of vertical.
 - c) Connect cable assembly (24) using washer and screw.
 - d) Install gasket, cover (25) and six screws.

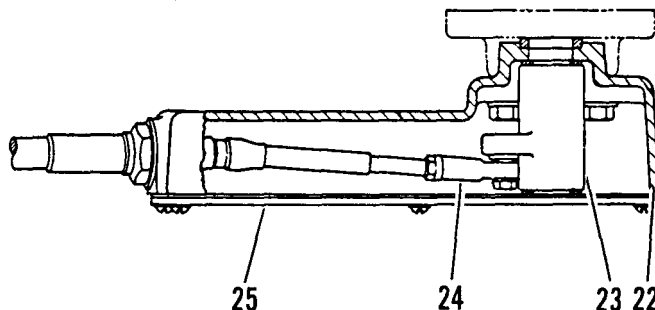

Models 950BNSCE and 950BSCE

ENGINE

DISASSEMBLY AND ASSEMBLY

ENGINE

15. Connect wires (18) to the solenoid and wires (19) to the starter.



NOTE: Models 950BNS and 950BS shown. Hose locations for models 950BNSCE and 950BSCE are slightly different.

16. Connect air lines (20) to the engine as shown.

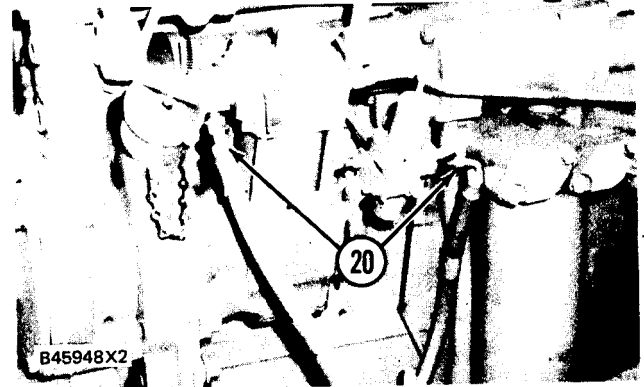

17. Connect engine disconnect switch (21) to the frame.
end by:
a) install rear drive shaft

WARNING

If NBC exposure is suspected, all air filter media should be handled by personnel wearing protective equipment. Consult your unit NBC Officer or NBC NCO for appropriate handling or disposal instructions.

- b) install air cleaner housing
- c) install muffler
- d) install radiator and guard
- e) install hood

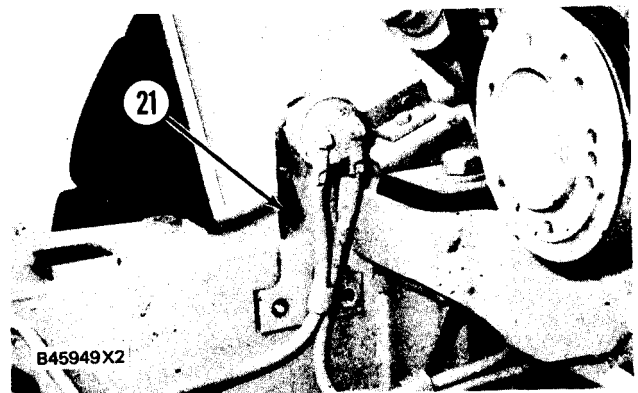

FLYWHEEL

REMOVE FLYWHEEL

1156-11

Tools Needed		A	B
9S8500	Engine Stand	1	
8S9908	Ratchet Puller		1

start by:

a) remove engine

1. Put the engine on tool (A) and use tool (B) to hold the rear of the engine in place as shown.
2. Remove two bolts and install two 5/8"- 18 NF twelve inches long guide bolts (1).
3. Remove the remainder of bolts (2) that hold the flywheel to the crankshaft.
4. Move flywheel (4) on the guide bolts just far enough to install strap (3) and a hoist. Remove flywheel (4) from the engine. The weight of the flywheel is 24 kg (53 lb.).

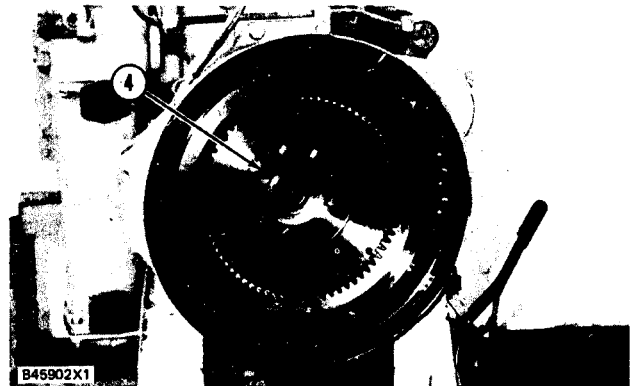
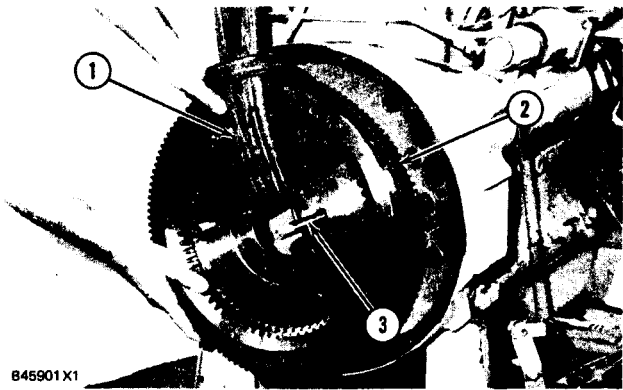
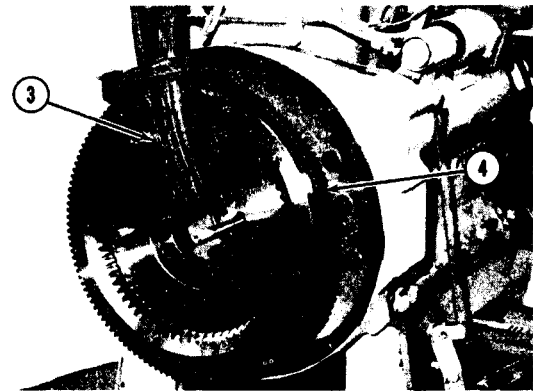
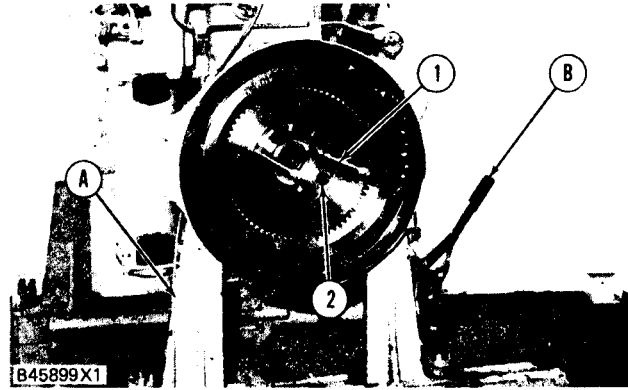

INSTALL FLYWHEEL

1156-12

Tools Needed		A	f	3
9S8500	Engine Stand	1		
8S9908	Ratchet Puller			1

1. If the flywheel ring gear has damage, a replacement can be made as follows:
 - a) Heat the ring gear to a maximum (emperature of 320°C (608°F) and install it on the flywheel so the chamfer of the gear teeth will be toward the starter pinion when the flywheel is installed.
2. Install two 5/8"-18 NF twelve inches long guide bolts (3) in the crankshaft.
3. Fasten strap (1) and a hoist to flywheel (2) and install it on the guide bolts. Make sure the mark on the flywheel is in alignment with the the mark on the crankshaft.
4. Remove the strap and put the flywheel in position on the end of the crankshaft.
5. Install bolts (4) that hold the flywheel to the crankshaft. Tighten the bolts to a torque of 205 ± 27 N·m (150 ± 20 lb.ft.).

end by:

a) install engine

ENGINE

FLYWHEEL HOUSING

REMOVE FLYWHEEL HOUSING 1157-11

Tools Needed		A	B
9S9060	Engine Stand	1	
FT120	Lifting Bracket		1

start by:

- a) remove torque converter oil cooler
- b) remove flywheel
- c) remove starting motor

1. Put the engine on tooling (A) with the rear supports in position as shown.

2. Remove oil pan plate bolts (1) and loosen oil pan bolts (2).

3. Install shims (3) on each side of the engine between the cylinder block and oil pan plate as shown.

4. Remove two bolts (4) from the top of the flywheel housing.

5. Fasten tool (B) to flywheel housing (6) as shown.

NOTE: Be careful not to damage the crankshaft rear seal when flywheel housing (6) is removed.

6. Remove bolts (5) and remove flywheel housing (6). The weight of the flywheel housing is 37 kg (82 lb.).

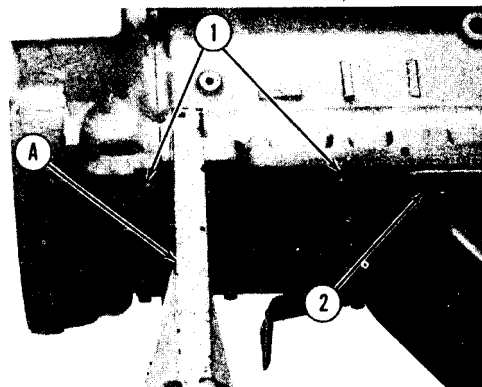

B52841X1

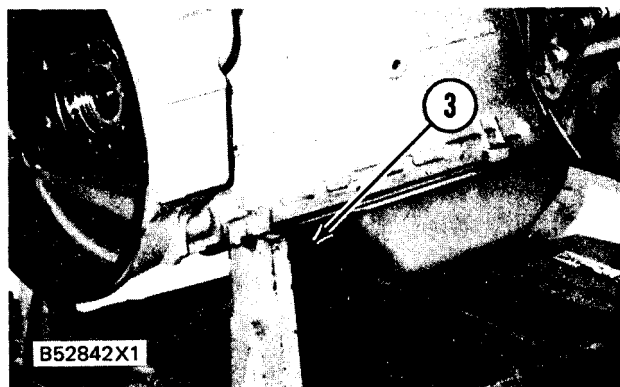

B52842X1

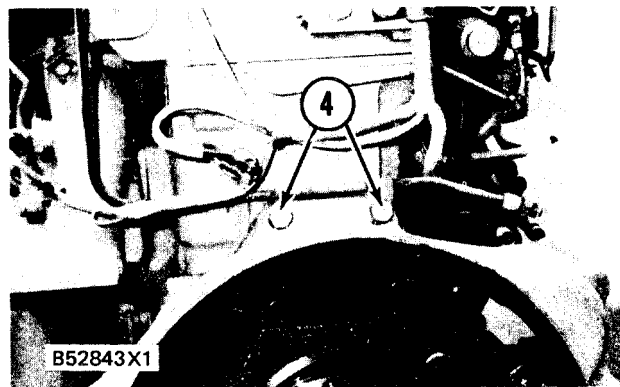

B52843X1

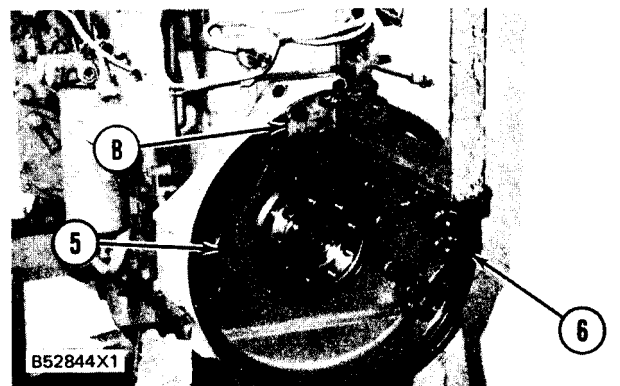

B52844X1

FLYWHEEL HOUSING

INSTALL FLYWHEEL HOUSING 1157-12

Tools Needed		A	B
FT120	Lifting Bracket	1	
9S9060	Engine Stand		1

1. Clean the old gasket from the surfaces of the cylinder block and flywheel housing that make contact with each other. Install a new gasket (1) on the cylinder block.

2. Install two ½"-13 NC guide bolts (2) in the cylinder block as shown.

NOTE: Be careful not to damage the crankshaft rear seal when flywheel housing (3) is installed.

3. Fasten tool (A) and a hoist to flywheel housing (3) and install it on the cylinder block.

4. Tighten the flywheel housing bolts in the sequence as shown in illustration B8984X1.

5. Cut the bottom of the gasket even with the flywheel housing and cylinder block. Put 5H2471 Gasket Cement on the bottom of the gasket where the gasket makes contact with the gasket for the oil pan plate. Remove shims (4) from each side and tighten all of the oil pan bolts. Install the bolts that hold the oil pan plate to the flywheel housing.

end by:

- a) install torque converter oil cooler
- b) install flywheel
- c) install starting motor

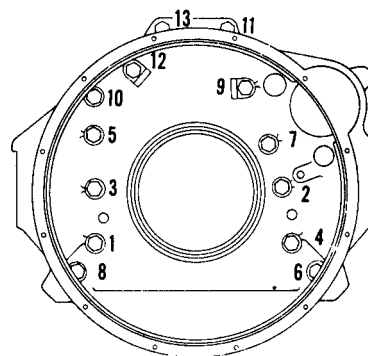
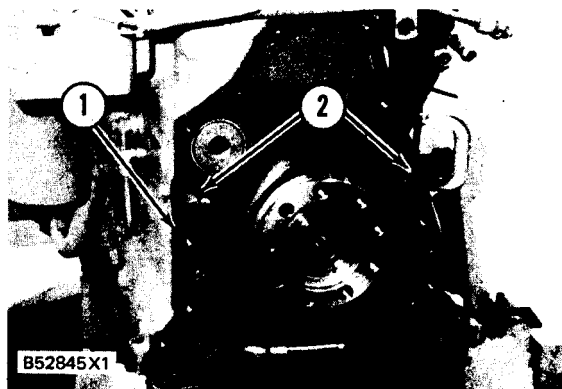

B8984X1

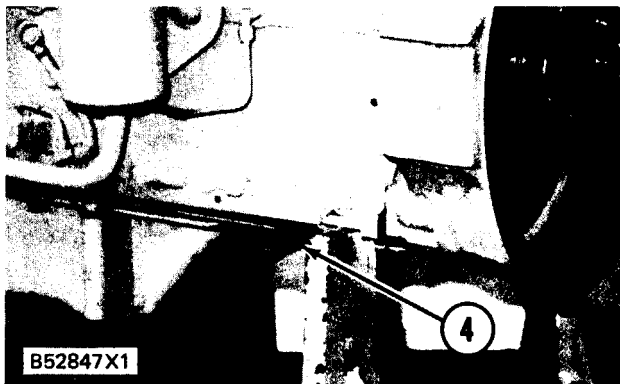

CRANKSHAFT REAR SEAL AND WEAR SLEEVE

REMOVE CRANKSHAFT REAR SEAL AND WEAR SLEEVE

1161-11

Tools Needed		A	B	C
1P3075	Puller Assembly	1		
5P7409	Distorter		1	
5P7313	Ring			1

start by:

- a) remove flywheel

NOTE: When a replacement of the rear seal is made, a replacement of the wear sleeve is to be made also.

1. Remove the crankshaft rear seal with tool (A).
2. Install tool (C) in the rear seal bore.
3. Install tool (B) between tool (C) and the wear sleeve. Turn tool (B) until the edge of the tool makes a flat place (crease) in the wear sleeve. Do this in two or more places until the wear sleeve is loose.

- 4 Remove tool (C) and the wear sleeve by hand.

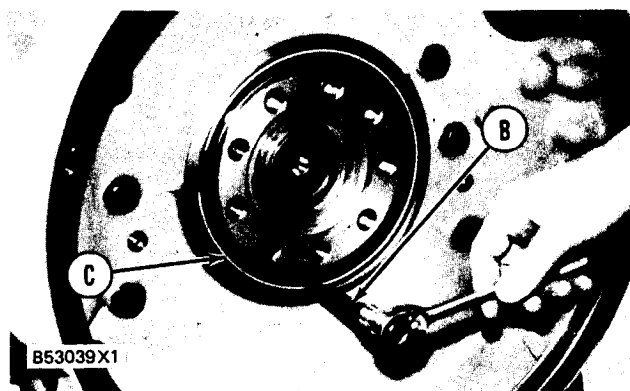

INSTALL CRANKSHAFT REAR SEAL AND WEAR SLEEVE

1161-12

Tools Needed		A
9S8871	Locator	1
9S8858	Nut	1
9S8890	Bolt	3
5P7298	Installer	1

1. Install the crankshaft rear seal and wear sleeve with tooling (A) as follows:

- a) Put locator (1) in position on the crankshaft and install the three bolts that hold it in place.
- b) Put clean engine oil on the seal lip of seal (6) and on the outside diameter of wear sleeve (2).
- c) Install seal (6) on wear sleeve (2) from the end of the wear sleeve that has the bevel on the outside diameter. Make sure the lip of the seal is toward the inside of the engine and the bevel that is on the outside diameter of the wear sleeve is toward the outside of the engine when installed.
- d) Use 6V1541 Quick Cure Primer to clean the outside diameter of the crankshaft flange (3) and the inside diameter of wear sleeve (2).
- e) Put 9S3265 Retaining Compound on the outside diameter of crankshaft flange (3) and the inside diameter of wear sleeve (2).

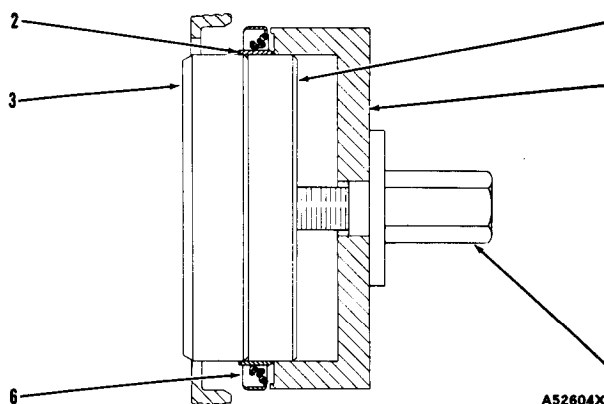

NOTE: Make sure the lip of the seal is toward the inside of the engine and the outside diameter bevel of the wear sleeve is toward the outside of the engine.

- f) Put wear sleeve (2) with seal (6) on locator (1). Put installer (4) on locator (1) and install nut (5). Put lubrication on the face of the washer and the nut.
 - g) Tighten nut (5) until installer (4) comes in contact with locator (1).
 - h) Remove tooling (A) and check the wear sleeve and seal for correct installation.
- end by:
- a) install flywheel

FUEL TANK

REMOVE FUEL TANK

1273-11

Tools Needed		A	B
6V2156	Link Bracket	2	4
5P9736	Link Bracket	1	
8S9906	Ratchet Puller	1	

1. Drain the fuel tank below the level of the fuel lines.
2. Remove bolt (2) to disconnect the clip from the fuel tank.
3. Disconnect wire assembly (1) from the fuel tank.
4. Remove bolts (4) and ladder (3) from the fuel tank.
5. Remove the bolts, handrail (6) and plate (5) from the platform.
6. Fasten tooling (A) and a hoist to platform (3) as shown.
7. Remove bolts (7) and platform (8) from the machine. The weight of the platform is 68 kg (150 lb.).
8. Remove the bolts and disconnect clips (9) that hold the trasmission fill and dipstick to the fuel tank.

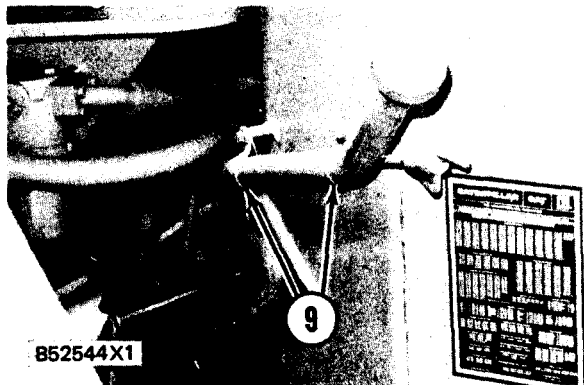
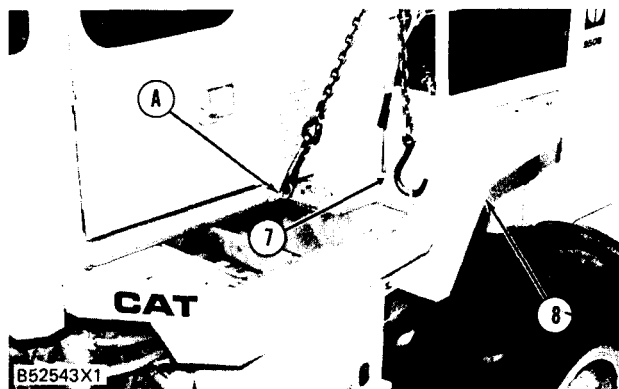
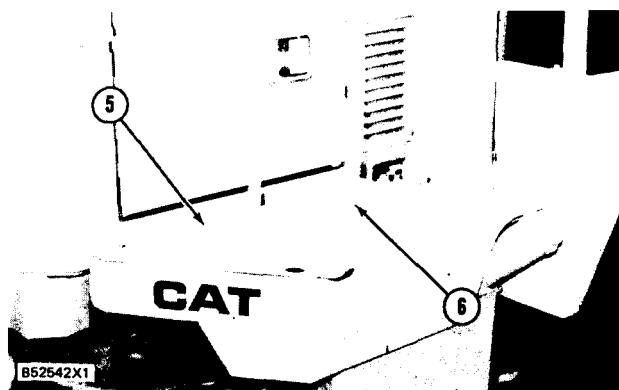
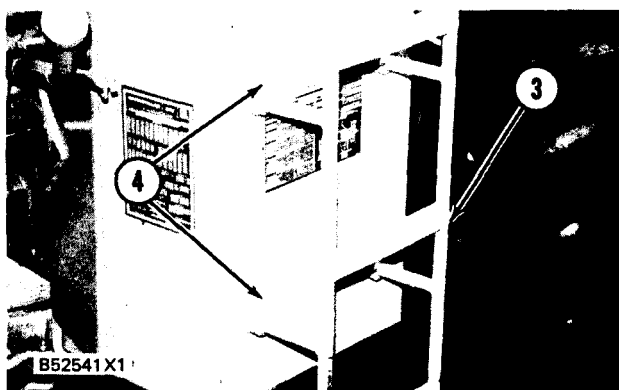
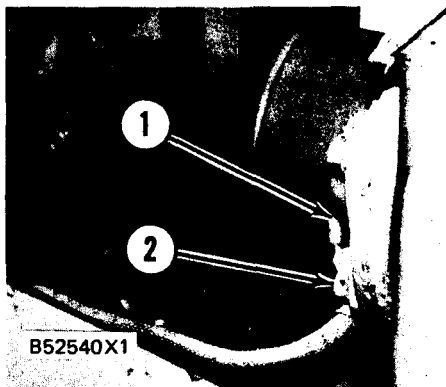

FUEL TANK

9. Disconnect fuel lines (10) and (11) from the rear of the fuel tank.

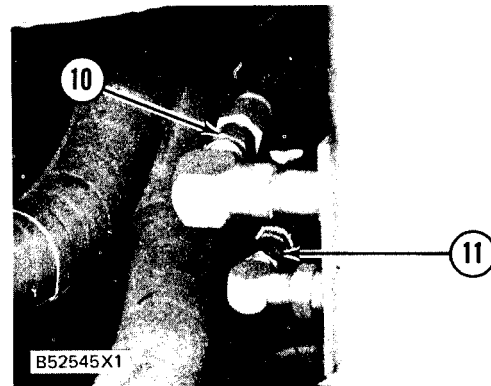

10. Fasten tooling (B) and a hoist to the fuel tank. Remove bolts (12) from the bottom of the fuel tank.

11. Remove bolts (13) and fuel tank (14) from the machine. The weight of the fuel tank with 20 % fuel is 136 kg (300 lb.).

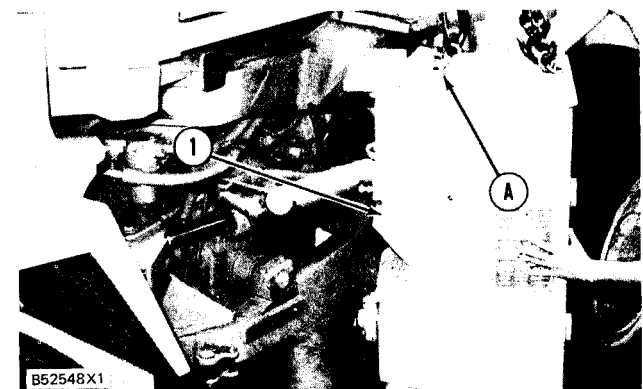
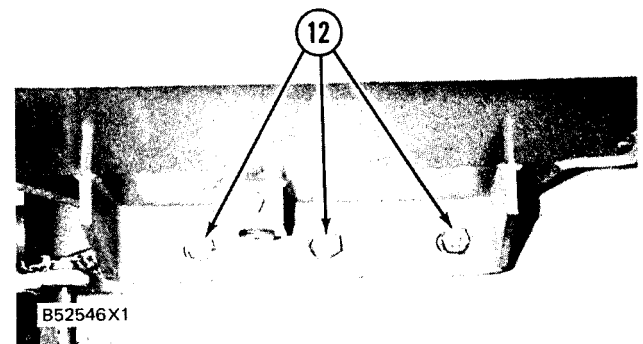
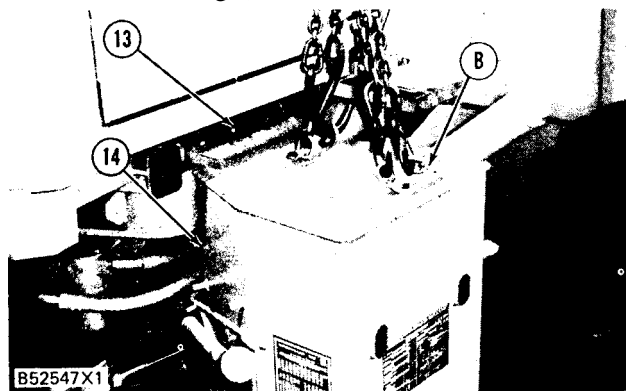

INSTALL FUEL TANK

1273-12

Tools Needed		A	B
6V2156	Link Bracket	4	2
5P9736	Link Bracket		1
8S9906	Ratchet Puller		1

1. Fasten tooling (A) and a hoist to fuel tank (1). Put fuel tank (1) in position on the machine and install the bolts that hold it.

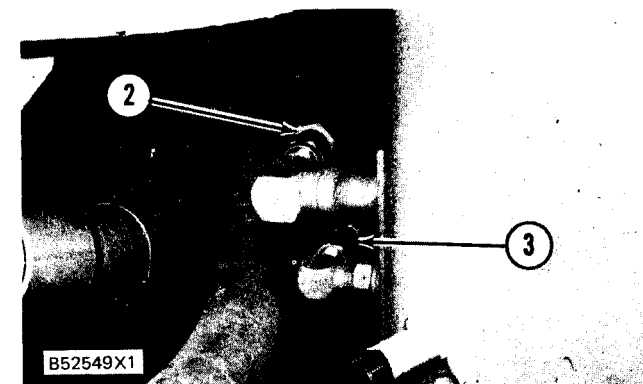

2. Connect fuel lines (2) and (3) to the fuel tank.

FUEL TANK

3. Connect clips (4) that hold the transmission fill tube and dipstick to the fuel tank.

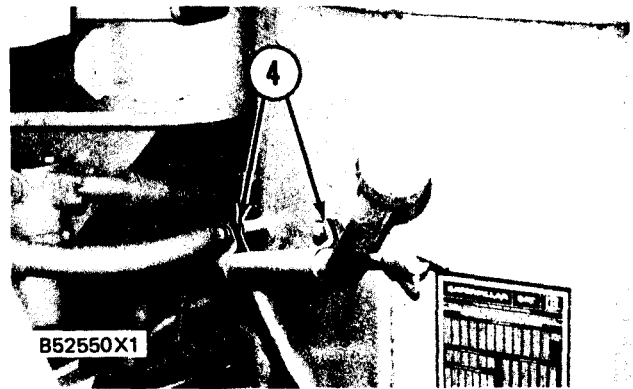

4. Fasten tooling (B) and a hoist to platform (5) and install it on the machine with the bolts that hold it.

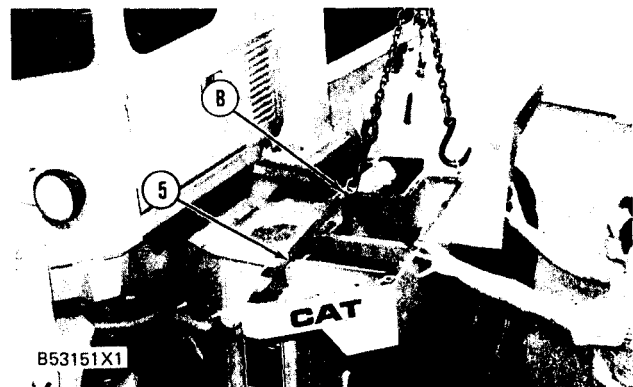

5. Install plate (7) and hand rail (6) on the platform as shown.

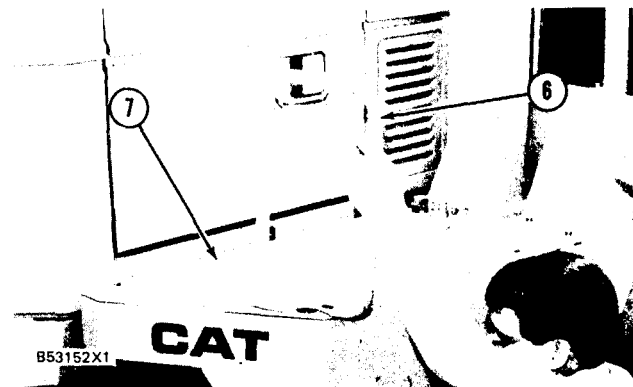

6. Put ladder (8) in position on the fuel tank and install the bolts that hold it.

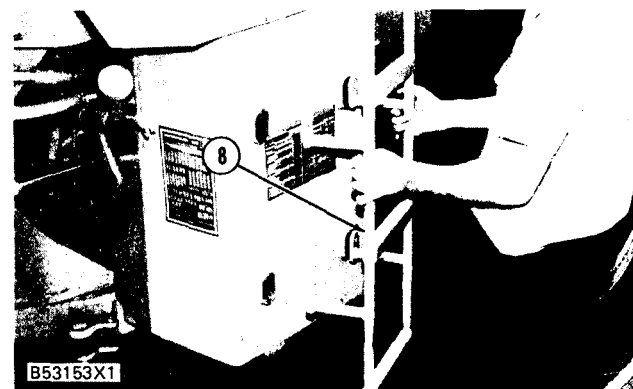

7. Install bolt (10) that holds the clip to the fuel tank.

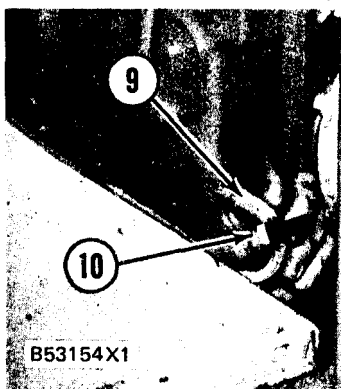

8. Connect wire assembly (9) to the fuel tank.

ANTI-PIVOT LINK

SEPARATION AND CONNECTION OF ANTI-PIVOT LINK 7506-29

WARNING

No clearance for man in this area when turning vehicle. When machine is to be lifted, transported on another vehicle or service work being preformed near center of machine, connect anti-pivot link between front and rear frames to keep machine in straight ahead position. Before operation and when operating, be sure anti-pivot link, located near lower center of machine, is disconnected and pinned to retaining plates.

1. Put machine in a straight ahead position.
2. Remove spring clip (5) and pin (2) that holds anti-pivot link (3).
3. Remove pin (4) and pin (1) from the bracket on the front frame.
4. Move anti-pivot link (3) to the front frame. Install pin (1) and pin (4) that holds anti-pivot link (3) in place.
5. Remove pin (4) and pin (1) that holds anti-pivot link (3) in place on the front frame.
6. Move anti-pivot link (3) into the storage position. Install pin (2) and spring clip (5) that holds the anti-pivot link in place.

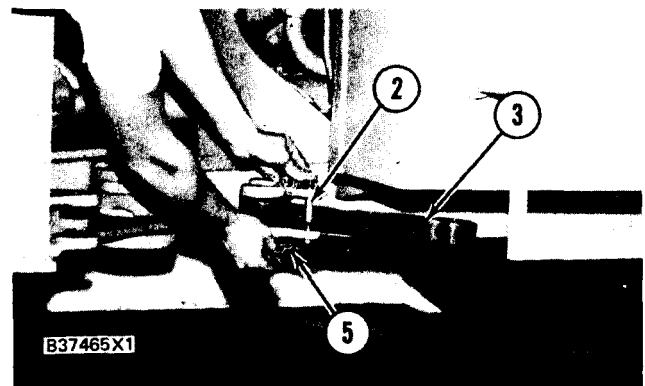
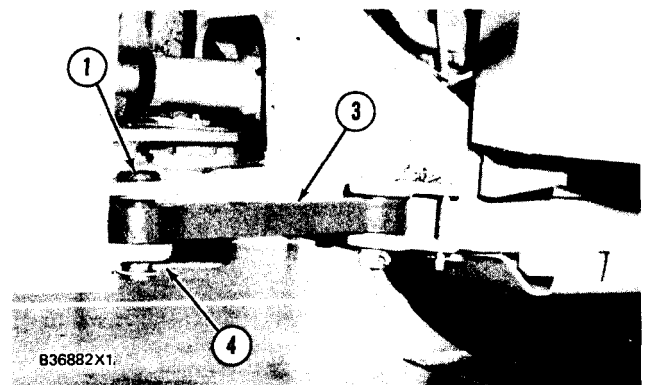
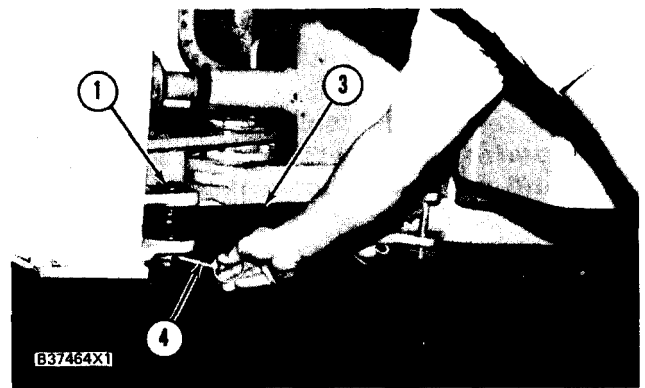
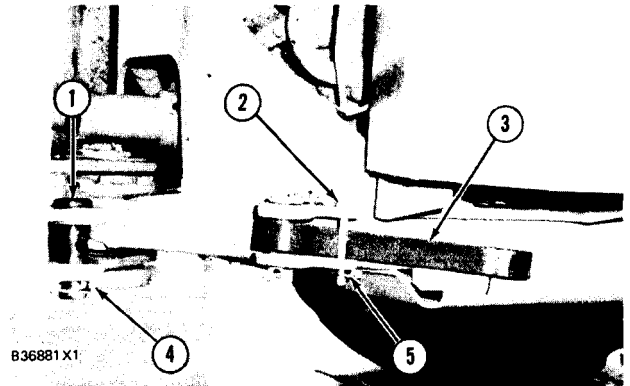

TIRES AND RIMS

REMOVE TIRES AND RIMS

4202-11

Tools Needed		A	B
8S7621	Tube	2	
8S7630	Stand	2	
8S7615	Pin	2	2
8S7640	Stand		2
8S7611	Tube		2

WARNING

No clearance for man in this area when turning vehicle. When machine is to be lifted, transported on another vehicle or service work being performed near center of machine, connect anti-pivot link between front and rear frames to keep machine in straight ahead position. Before operation and when operating, be sure anti-pivot link, located near lower center of machine, is disconnected and pinned to retaining plates.

1. Lift the rear of the machine so the tires are off the ground and install tooling (A) under the rear frame.
2. Put wood blocks (1) between the rear axle housing and frame on each side of the machine to hold the axle housing in position when the tires and rims are removed.
3. For the removal of the front tires and rims put wood blocks behind the rear tires. Lift the front of the machine so the tires are off the ground and install tooling (B) under the loader frame as shown.
4. Fasten a hoist to tire and rim (2). Remove the nuts and washers that hold the tire and rim to the wheel assembly. Remove tire and rim (2) from the machine. The weight of each tire and rim is 544 kg (1200 lb.).

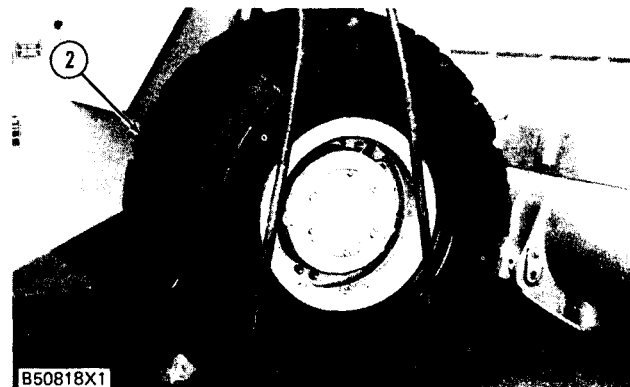
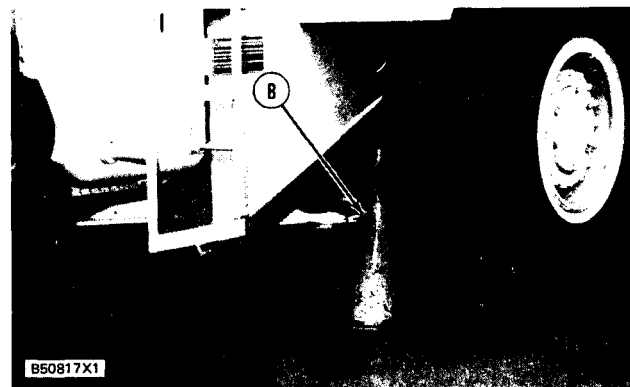
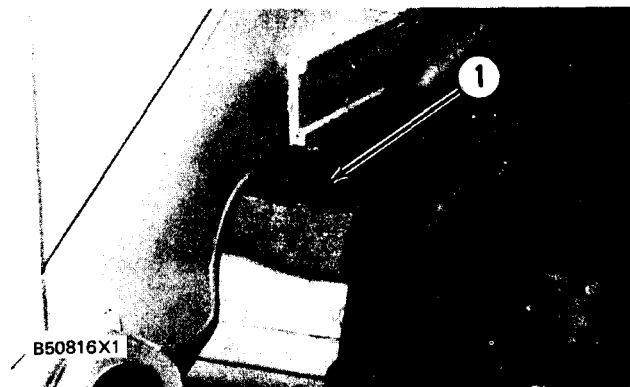
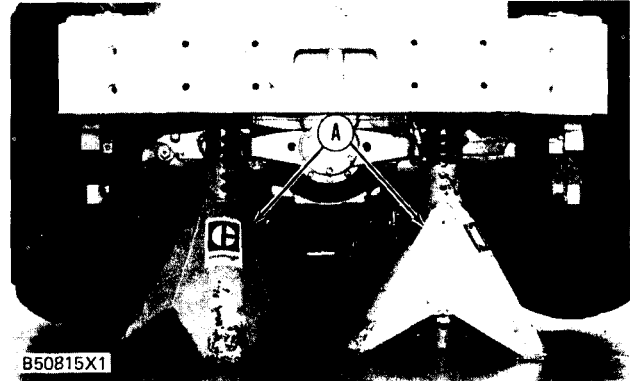

TIRES AND RIMS

INSTALL TIRES AND RIMS

4202-12

Tools Needed		A	B
8S7640	Stand	2	
8S7611	Tube	2	
8S7615	Pin	2	2
8S7630	Stand		2
8S7621	Tube		2



1. Fasten a hoist to tire and rim (1) and put it in position on the wheel assembly.

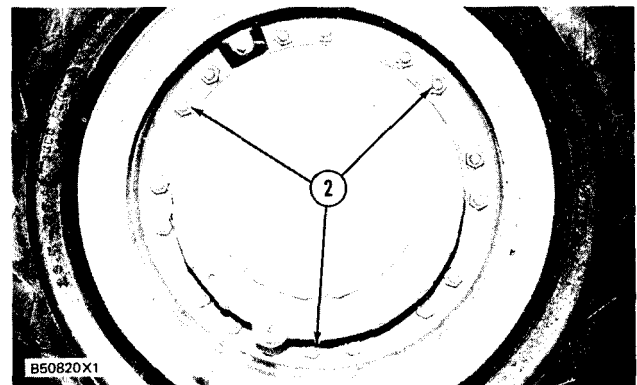

2. Install the washers and nuts (2) to hold tire and rim (1). Tighten the nuts to a torque of 475 ± 50 N·m (350 ± 37 lb.ft.).

3. Lift the front of the machine and remove tooling (A) from the loader frame.

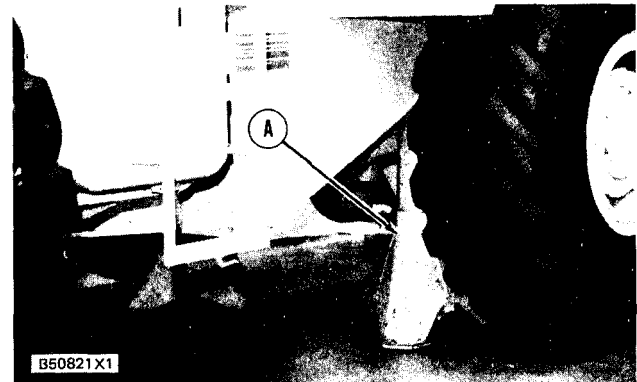

4. Remove the blocks from between the rear axle housing and frame.

5. Lift the rear of the machine and remove tooling (B).

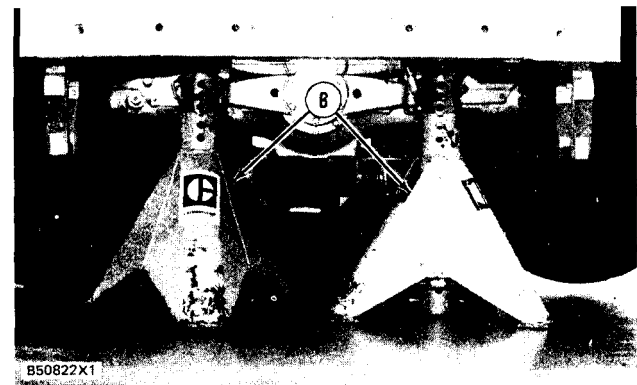

6. Disconnect the anti-pivot link from the main frames and put it in its storage position.

AXLES

REMOVE AXLES

3278-11

Tools Needed		A
2P8312	Pliers	1

1. Move the machine to put drain plug (2) in the position shown. Remove plug (2) and drain the oil from the final drive.

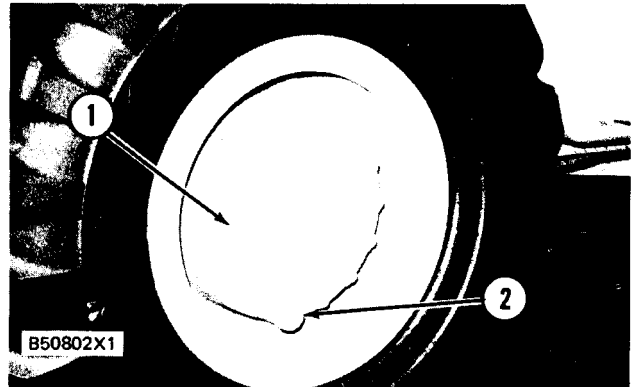

2. Remove the bolts and cover assembly (1). Check the O-ring seal in the cover for wear or damage. If necessary, make a replacement.

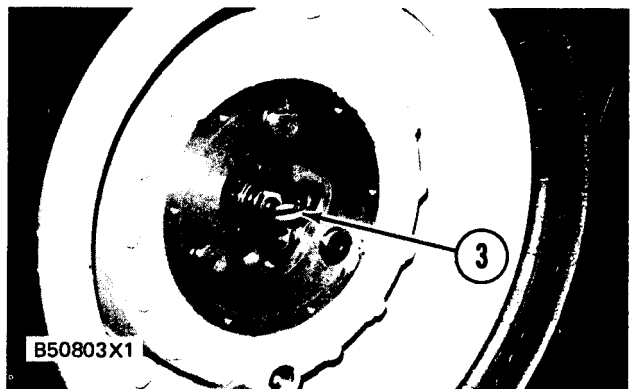

3. Install a 1/2"-13 NC forged eyebolt (3) in the end of the axle as shown. Pull the axle (4) out of the final drive until a hoist can be fastened to it.

4. Fasten a hoist and remove axle (4) from the machine. The weight of axle (4) is 23 kg (50 lb.).

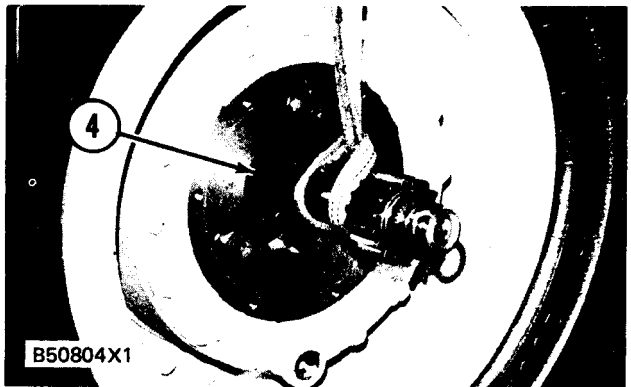

NOTE: If the axle can not be removed, move the machine a small amount to the front or rear until the axle can be pulled from the differential and final drive.

5. Use tool (A) and remove ring (6) from the axle.

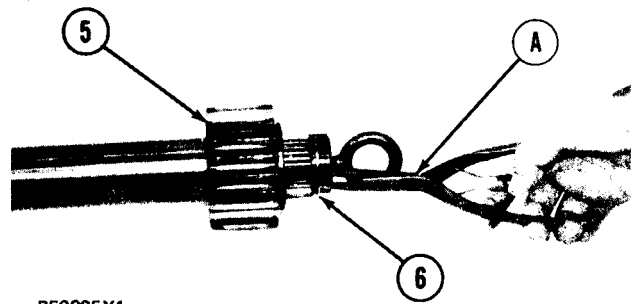

6. Remove gear (5) from the axle.

AXLES

INSTALL AXLES

3278-12

Tools Needed		A
2P8312	Pliers	1

1. Make sure the axles are clean and free of dirt and foreign material.
2. Fasten a hoist and put axle (1) in position.
3. Install gear (2) half way on the axle.
4. Put a piece of pipe (3) which has a 5.1 cm (2 in.) outside diameter and 61 cm (24 in.) long in the end of gear (2) as shown. Push down on the pipe and slide the drive axle into position.
5. Remove the pipe. Slide gear (2) into position in the final drive planetary. Use tool (A) and install ring (4) that holds gear (2) in position on the axle.
6. Turn the flat sides of the three shafts (5) toward the outside as shown to give clearance for the counterbore in cover (7).

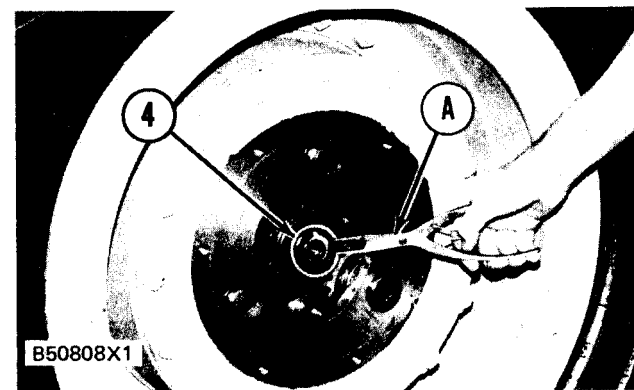
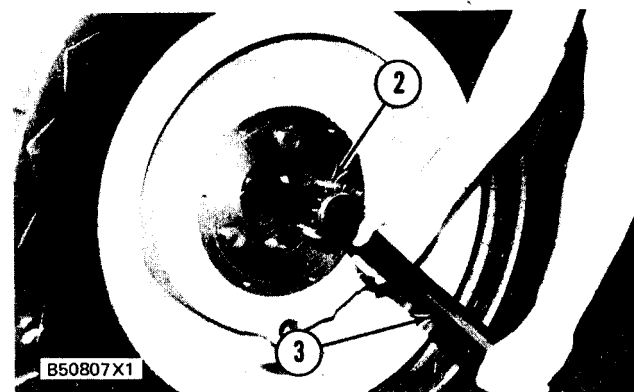
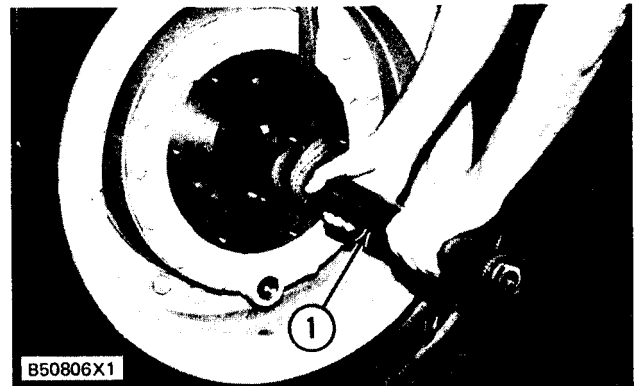

CAUTION
If the cover does not fit flat up against the final drive without force, remove the cover and do Step 6 again.

7. Put clean oil on O-ring seal (6) and install cover (7).
8. Install the O-ring seal on plug (8) and install it in the final drive.
9. Fill the final drives with oil to the correct level. See LUBRICATION AND MAINTENANCE GUIDE.

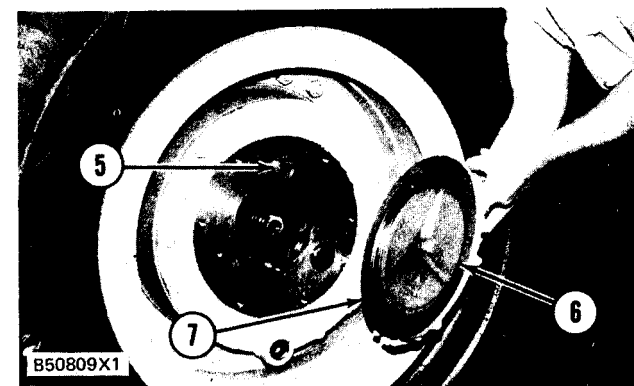
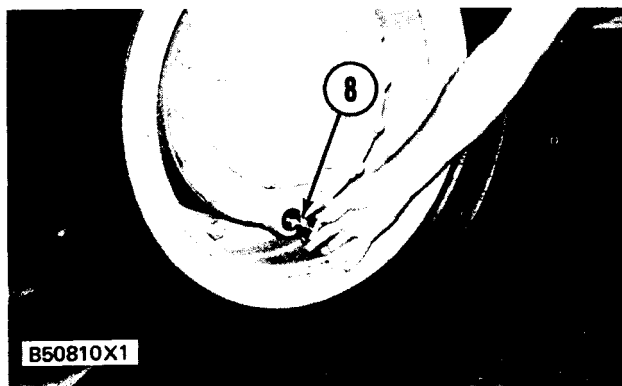

FINAL DRIVE

REMOVE FINAL DRIVES

4050-11

Tools Needed		A
5P9736	Link Bracket	2

start by:

a) remove axles

1. Remove two bolts from the wheel assembly and install two 5/8"-11 NC guide bolts (1) in their place.
2. Install tooling (A) on the final drive planetary carrier as shown.
3. Fasten a hoist to tooling (A). Remove the remainder of the bolts that hold the final drive planetary carrier to the wheel assembly.
4. Install two 1/2"-13 NC forcing screws (2) and loosen final drive planetary carrier (3) from the wheel assembly. Remove the final drive planetary carrier from the machine. The weight of the unit is 57 kg (125 lb.).
5. Remove the O-ring seal from the planetary carrier.
6. Remove ring (4) and gear (5) from the hub.

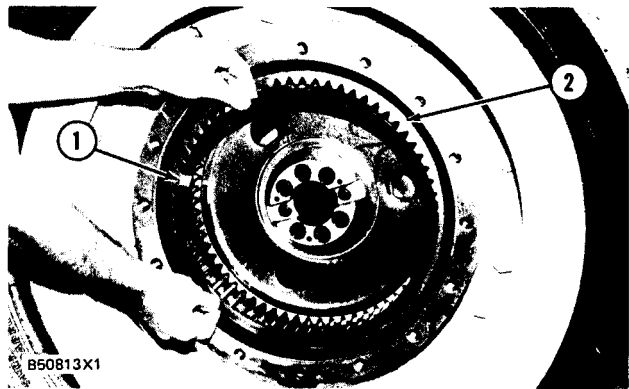
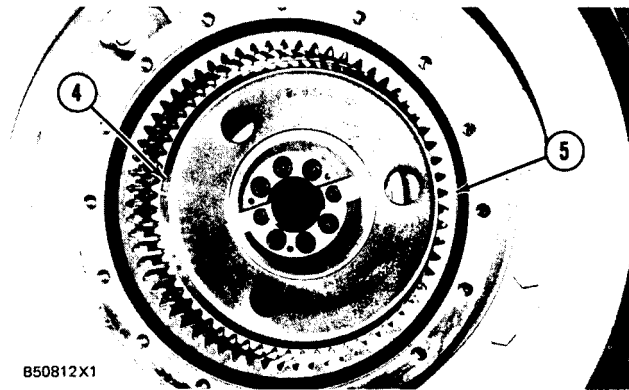
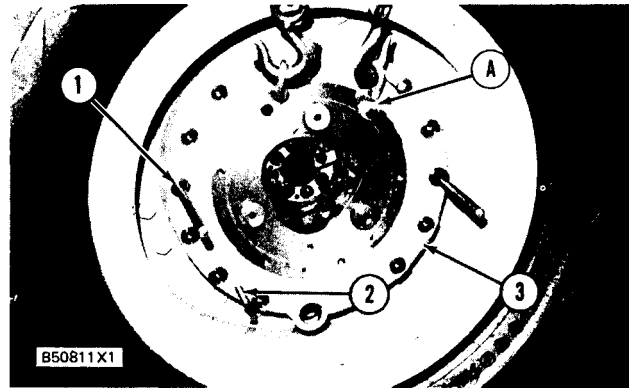

INSTALL FINAL DRIVES

4050-12

Tools Needed		A
5P9736	Link Bracket	2

1. Install gear (2) and ring (1) to the hub.
2. Install the O-ring seal around the final drive planetary carrier and put clean oil on it.
3. Install two 5/8"-11 NC guide bolts (4) in the wheel assembly as shown.
4. Fasten a hoist to final drive planetary carrier (3) with tooling (A) and put the unit in position.
5. Tighten the bolts that hold final drive planetary carrier (4) to a torque of 270 ± 25 N·m (200 ± 18 lb. ft.).

end by:

a) install axles

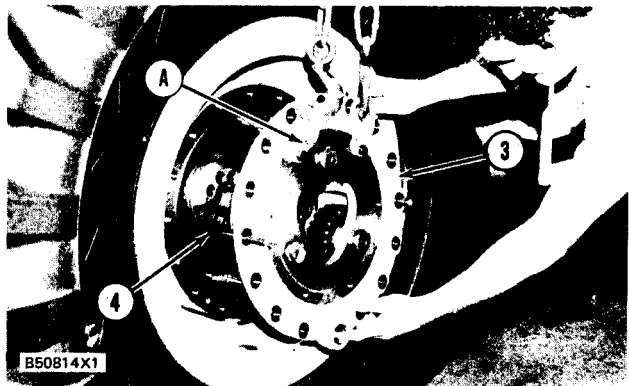

FINAL DRIVE PLANET CARRIERS

DISASSEMBLE FINAL DRIVE PLANET CARRIERS

4092-15

start by:

a) remove final drives

1. Lift three shafts (1) out of the carrier.
2. Remove three gears (2) and twelve spacers from the carrier.
3. Remove retainer rings (3) from shafts (1).
4. Remove two bearings (4) from each gear (2).

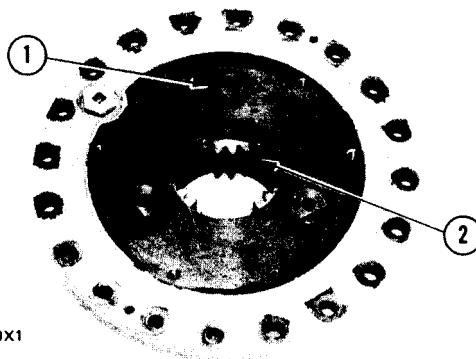

B29149X1

ASSEMBLE FINAL DRIVE PLANET CARRIERS

4092-16

1. Install bearings (1) in gears (2).
2. Install retainer rings (4) on shafts (3).
3. Put the gears in position in the carrier with steel spacers (6) next to the gears and bronze spacers (5) between the carrier and the steel spacers. Make sure the oil grooves on the steel spacers are toward the bronze spacers.
4. Install shafts (3) in the carrier. Make sure the flat side of the shafts are toward the outside of the carrier as shown.

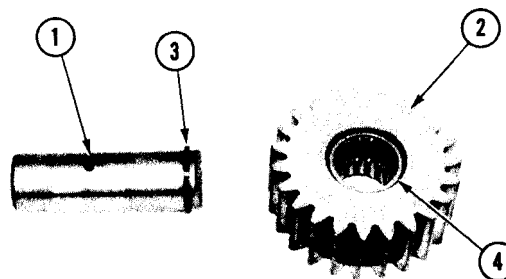

B29150X1

end by:

a) install final drives

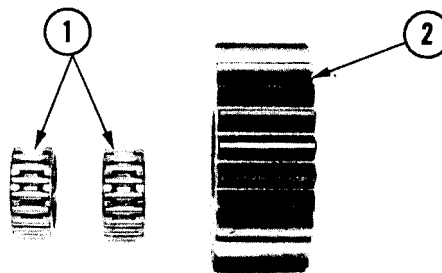

B29151X1

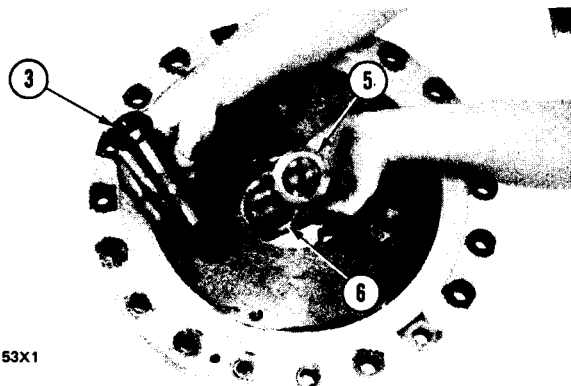

B29153X1

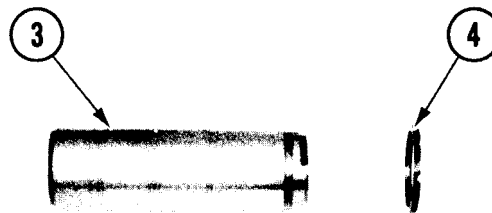

B29152X1

WHEELS, BEARINGS AND DUO-CONE SEALS

REMOVE WHEELS, BEARINGS AND DUO-CONE SEALS

4208-11

Tools Needed		A	B	C
6V2157	Link Bracket	1		
8S9906	Ratchet Puller	1		
1P520	Driver Group		1	1
1H3110	Bearing Puller Attachment			1
1H3107	Puller Assembly			1

start by:

- a) remove tire and rim
- b) remove brake head assemblies
- c) remove final drive

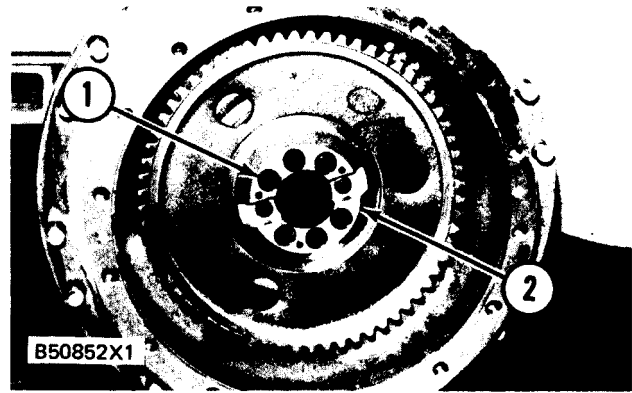

1. Fasten strap (3), tooling (A) and a hoist to wheel assembly (4) as shown.

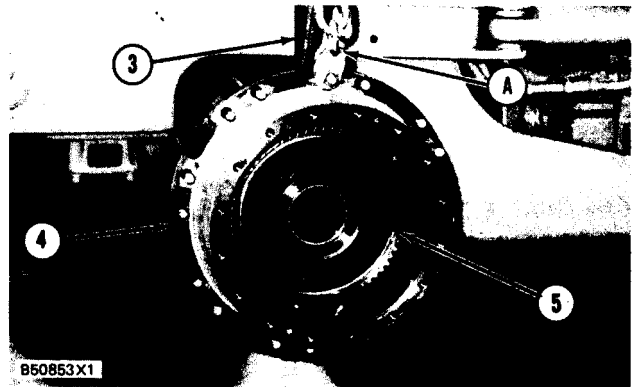

2. Remove bolts (1), plate (2) and the shims from wheel assembly (4).

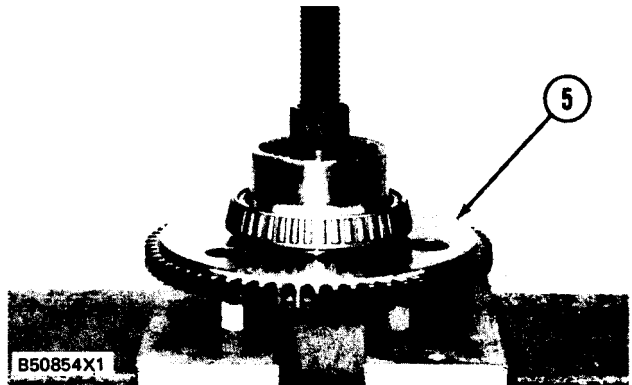

3. Remove hub (5) from the spindle.

4. Use tool (B) and a press to remove the bushing from the inside of hub (5).

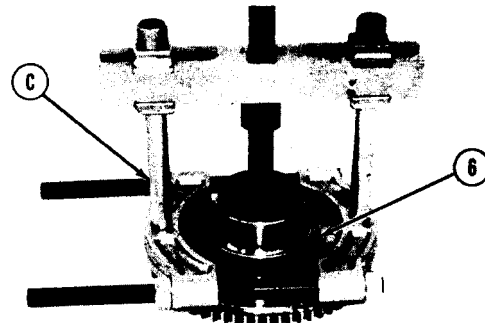

5. Use tooling (C) to remove bearing cone (6) from the hub.

WHEELS, BEARINGS AND DUO-CONE SEALS

6. Remove wheel assembly (4) from the spindle.
The weight of the wheel assembly is 98 kg (215 lb.).

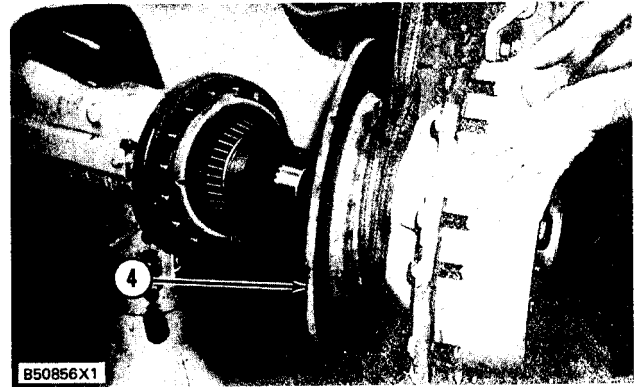

7. Remove the outer half of Duo-Cone seal (9) from the hub assembly.

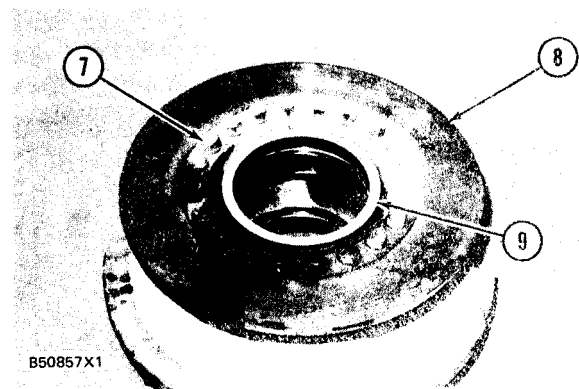

8. Remove bolts (7) and brake disc (8) from the hub assembly.

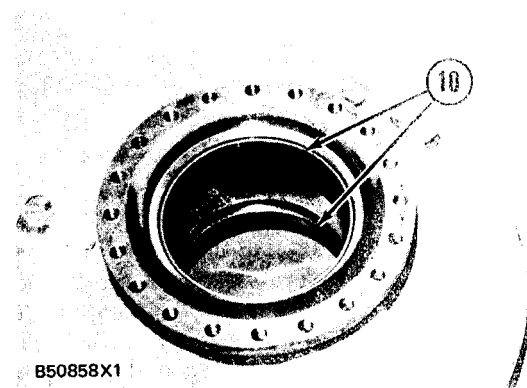

9. Remove bearing cups (10) from the hub.

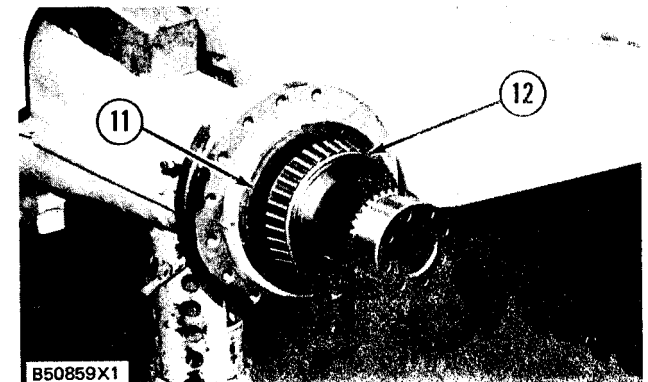

10. Remove inner half of Duo-Cone seal (11) and bearing cone (12) from the spindle.

WHEELS, BEARINGS AND DUO-CONE SEALS

INSTALL WHEELS, BEARINGS AND DUO-CONE SEALS

4208-12

Tools Needed		A	B	C
8M7911	Installer	1		
6V2157	Link Bracket		1	
8S9906	Ratchet Puller		1	
1P520	Driver Group			1

1. Make sure the rubber torus seals are clean and dry. Make sure all metal surfaces that make contact with the rubber torus seals are clean and dry. Use tool (A) to install the Duo-Cone seal in the retainer. Put a small amount of clean oil on the surfaces of the metal seals that make contact with each other.
2. Install bearing cone (1) on the spindle.
3. Lower the temperature of bearing cups (2) and install them in the wheel assembly.
4. Put brake disc (3) in position on the wheel assembly and install the bolts. Tighten the bolts to a torque of 270 ± 25 N·m (200 ± 18 lb.ft.).
5. Make sure rubber torus seals are clean and dry. Make sure all metal surfaces that make contact with the rubber torus seals are clean and dry. Use tool (A) to install the Duo-Cone seal in the wheel assembly. Put a small amount of clean oil on the surfaces of the metal seals that make contact with each other.

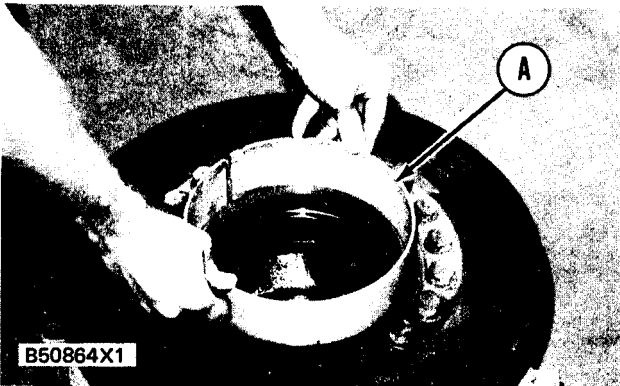
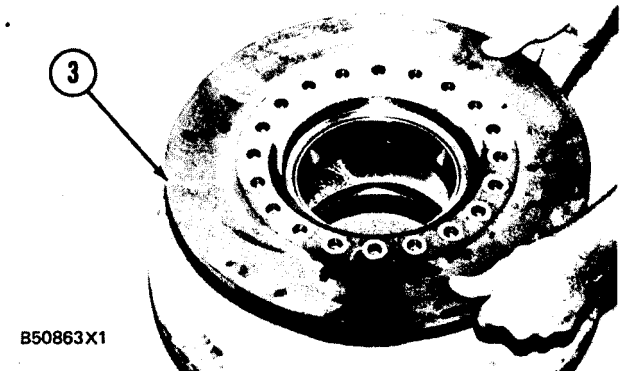
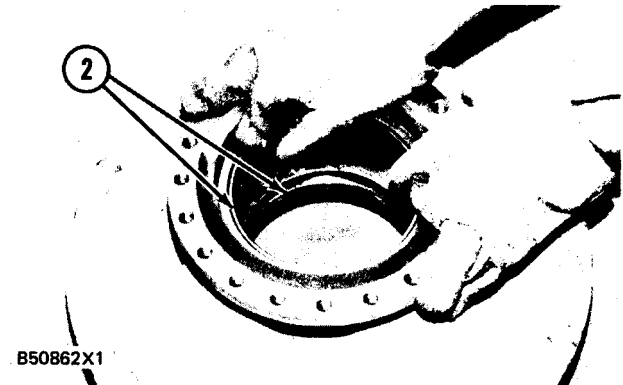
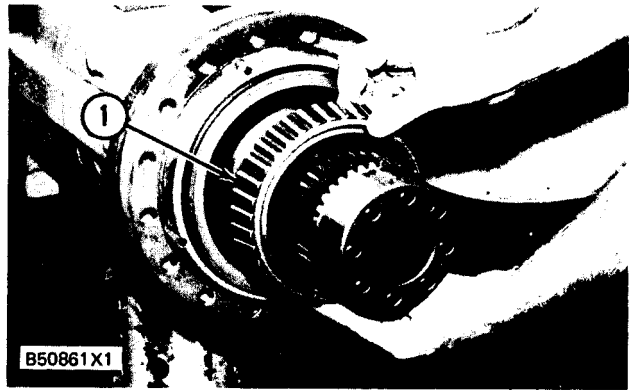
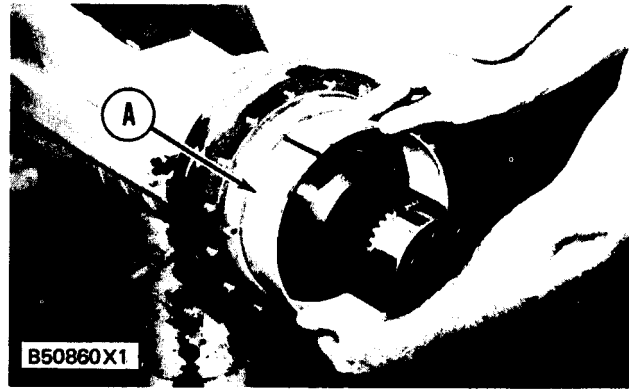

POWER TRAIN

WHEELS, BEARINGS AND DUO-CONE SEALS

6. Use tooling (B) and strap (4) to wheel assembly (5) as shown. Put wheel assembly (5) in position on the spindle.

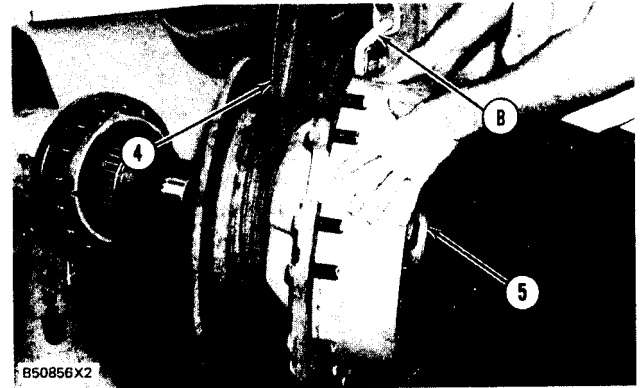

7. Heat bearing cone (6) to a maximum temperature of 135°C (275°F) and install it on hub (7) as shown.

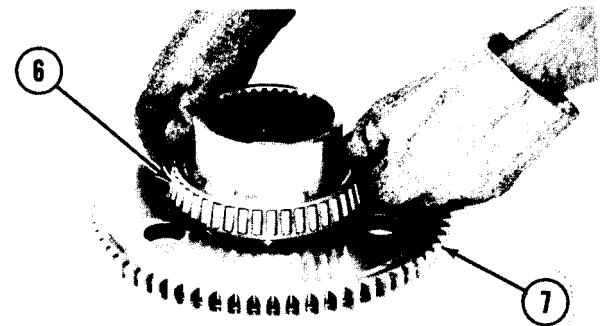

8. Use tool (C) and a press to install the bushing in hub (7).

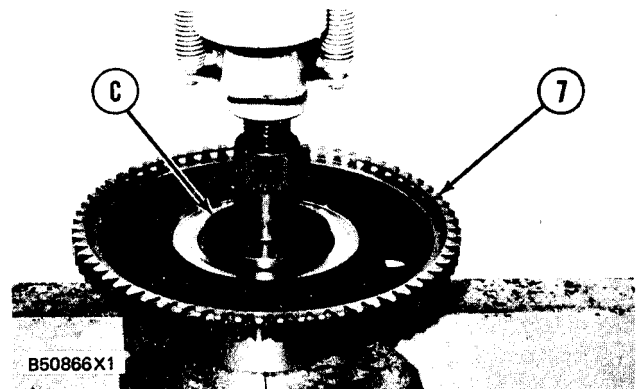

9. Install hub (7) and the bearing on the spindle.

10. Use an outside micrometer (8) and measure the thickness of plate (9) at the three small holes. Find the plate average thickness.

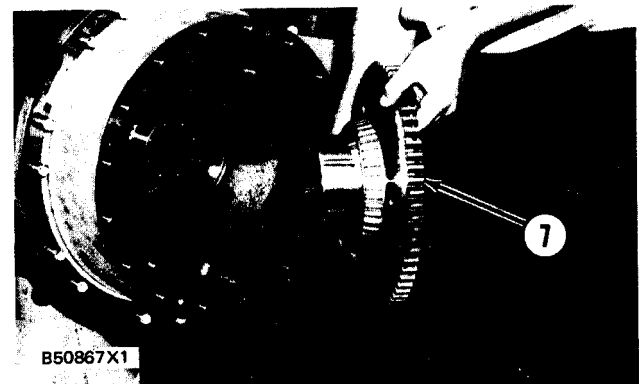
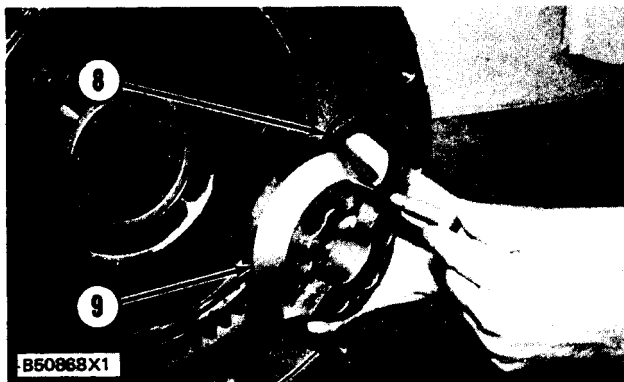

WHEELS, BEARINGS AND DUO-CONE SEALS

11. Install plate (9) without shims on the spindle. Install three of the bolts that hold it so there are even spaces between the bolts. Turn wheel assembly slowly by hand, and tighten the bolts to a torque of 100 ± 15 N·m (75 ± 11 lb.ft.). Loosen the bolts until the plate is free. Tighten the bolts again to a torque of 25 ± 7 N·m (20 ± 5 lb.ft.).

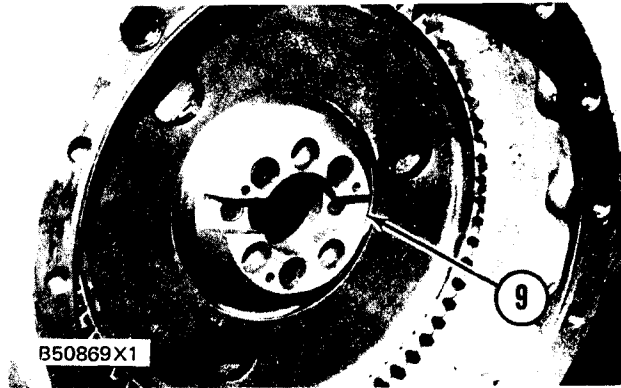

12. Use a depth micrometer (10) and measure through the three small holes in the plate. Find the average depth.

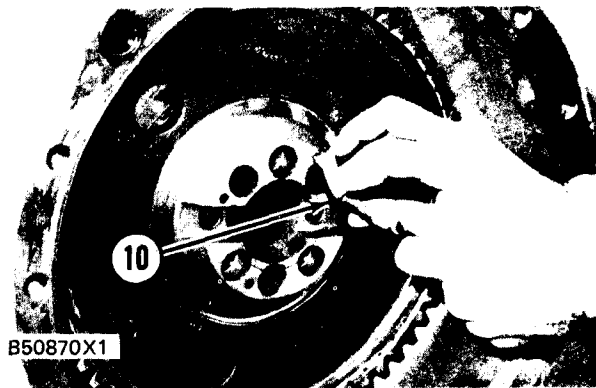

13. Find the difference between the two average measurements in Steps 10 and 12. The difference is the gap between the end of the spindle and the plate.

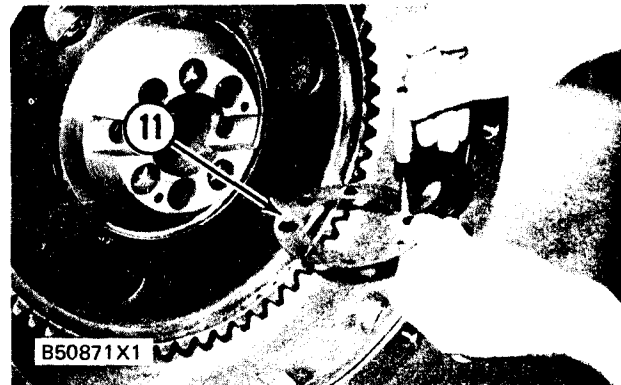

14. Remove the plate from the spindle. Install an amount of shims (11), the same thickness as the average gap found in Step 13 plus 0.13 mm (.005 in.).

15. Install plate (9) and all of the bolts. Tighten the bolts evenly to a torque of 150 ± 20 N·m (110 ± 15 lb.ft.).

end by:

- a) install tires and rims
- b) install brake head assemblies
- c) install final drive

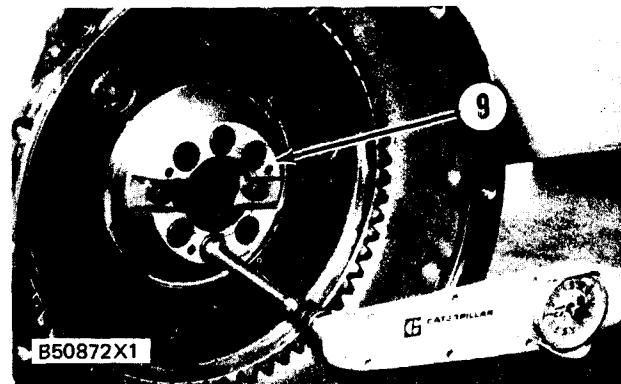

WHEEL BRAKE ASSEMBLY**REMOVE WHEEL BRAKE ASSEMBLY 4255-11**

Tools Needed		A
6V2156	Link Bracket	2

start by:

- a) remove tires and rims



1. Disconnect brake line (1) from the brake assembly.

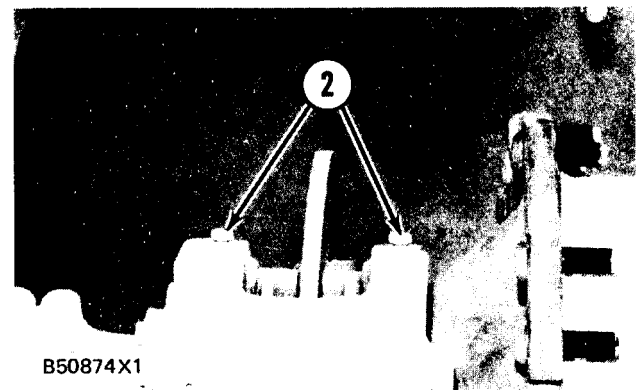

2. Remove bolts (2) from the brake assembly.

3. Install tooling (A) and a hoist on the brake assembly as shown.

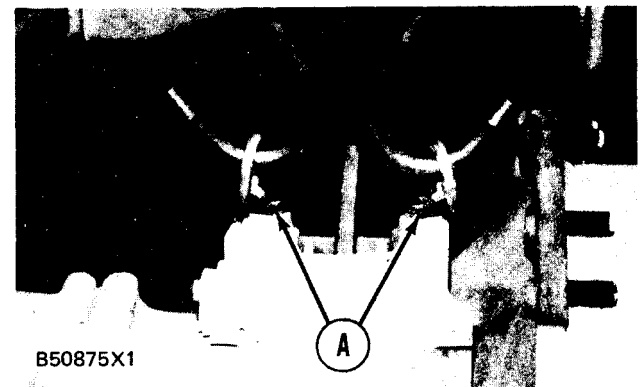

4. Remove bolts (4) and brake assembly (3) from the axle. The weight of the brake assembly is 45 kg (100 lb.).

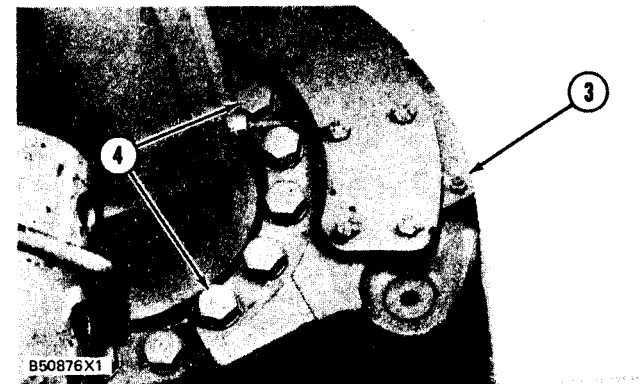

NOTE: It can be necessary to push the brake linings away from the disc to remove the brake assembly.

WHEEL BRAKE ASSEMBLY

INSTALL WHEEL BRAKE ASSEMBLY 4255-12

Tools Needed		A
6V2156	Link Bracket	2

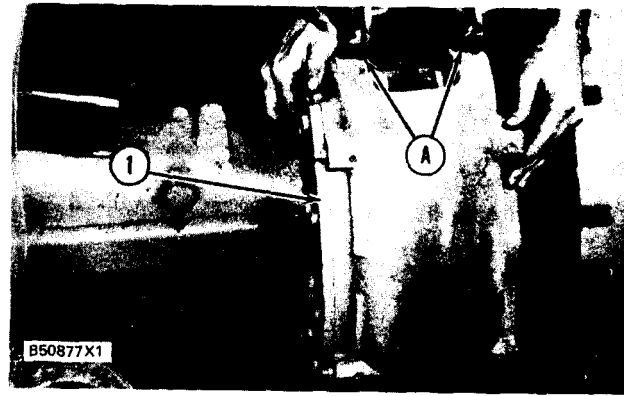

1. Fasten tooling (A) and a hoist to the brake assembly (1) and put it into position on the axle as shown.

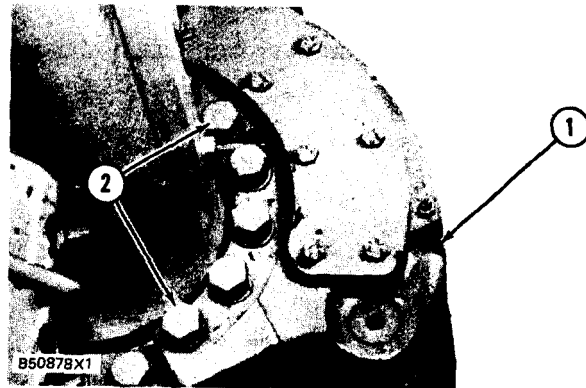

2. Install bolts (2) that hold brake assembly (1) to the axle. Tighten the bolts to a torque of 475 ± 50 N·m (350 ± 37 lb.ft.).

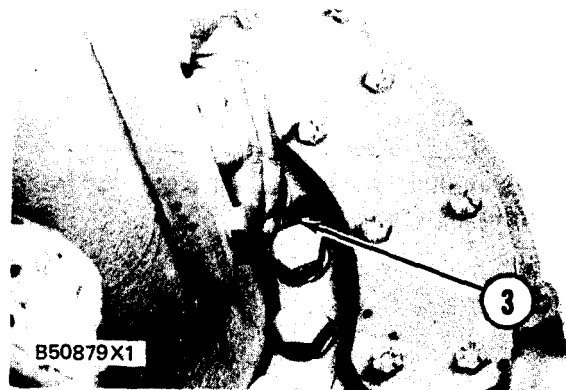

3. Connect brake line (3) to the wheel assembly as shown.

4. Loosen bolts (4) and use a feeler gauge (6) to make an adjustment of pins (5) so the distance between pins (5) and the disc is a minimum of 0.25 mm (.10 in.) and a maximum of 3 mm (.12 in.). Tighten bolts (4) to 45 ± 7 N·m (33 ± 5 lb. ft.).

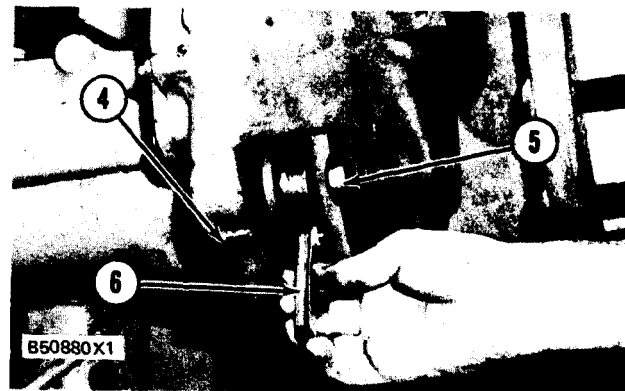

5. Remove (bleed) the air from the brake system. end by:
 a) install tires and rims

WHEEL BRAKE ASSEMBLY

DISASSEMBLE WHEEL BRAKE ASSEMBLY

4256-15

Tools Needed		A
3P2209	Compressor Tool	2

start by:

a) remove brake head assemblies

1. Remove four bolts (3) from the brake head assemblies.
2. Remove two pins (1) and brake carrier (2) from the brake head assembly.
3. Install tooling (A) on the brake head and the brake carrier (plate side) as shown.
4. Install block (4) so the maximum travel distance between block (4) and pistons (5) is not more than 35 mm (1.378 in.).
5. Put air free of water under a pressure of 690 to 1030 kPa (100 to 150 psi) into the brake head assembly to make force to move out pistons (5).
6. Remove the block tooling (A), the pins and brake carrier from the brake head assembly.
7. Remove pistons (5) from the brake head.
8. Remove bolts (6) and plate (7) from the brake head.
9. Remove plugs (8) from the brake head.

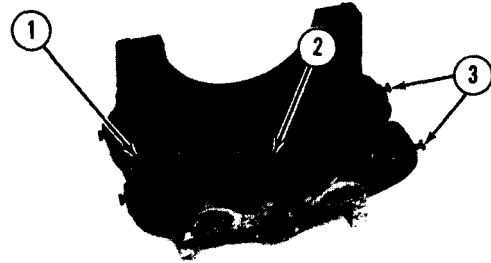

B54960X1

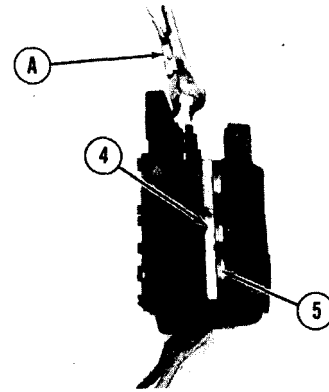

B54961X1

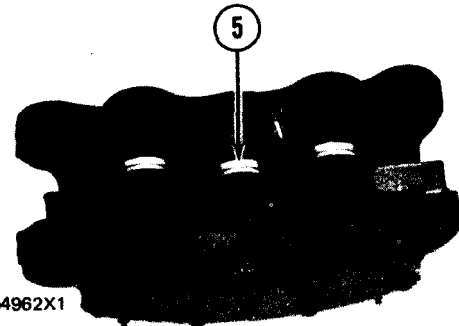

B54962X1

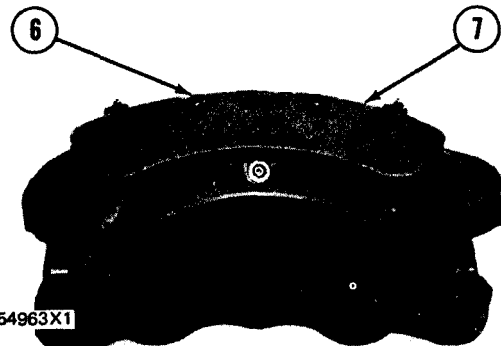

B54963X1

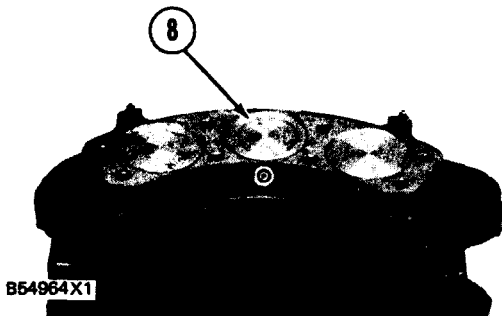

B54964X1

WHEEL BRAKE ASSEMBLY

10. Remove seals (9) from the brake head.

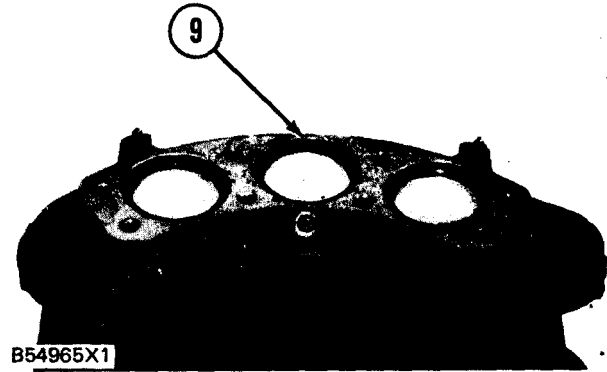

11. Remove pistons (10) from the brake head.

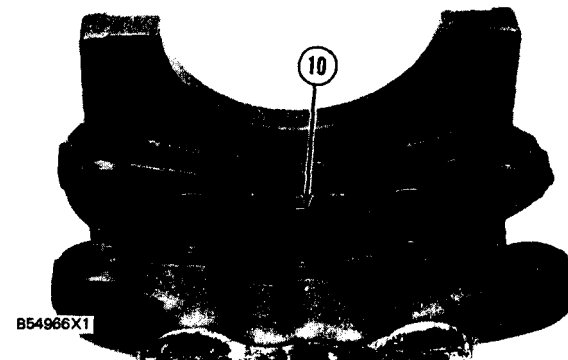

12. Remove boots (11) and seals (12) from both sides of the brake head.

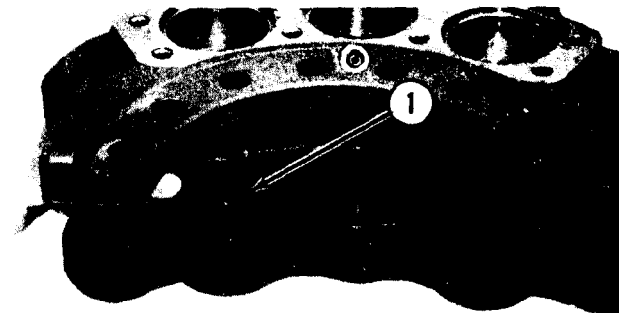

INSTALL WHEEL BRAKE ASSEMBLIES

4256-16

1. Install seals (1) in the brake head.

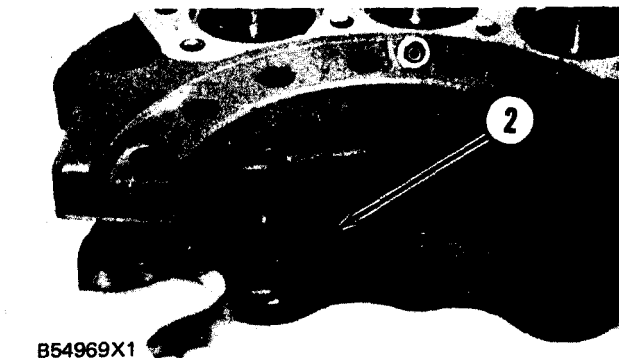

2. Install boots (2) in the brake head.

WHEEL BRAKE ASSEMBLY

3. Put pistons (3) into position in the brake head.

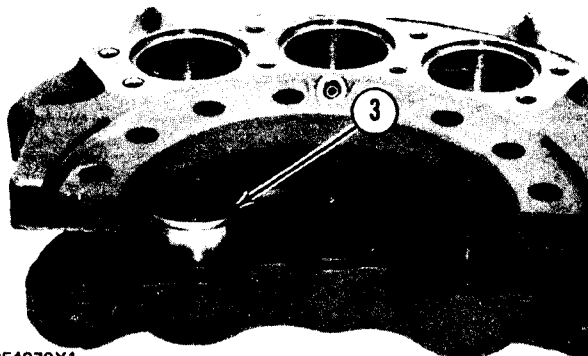

B54970X1

4. Install seals (4) (plate side) in the brake head as shown.

5. Install plugs (5) in the brake head as shown.

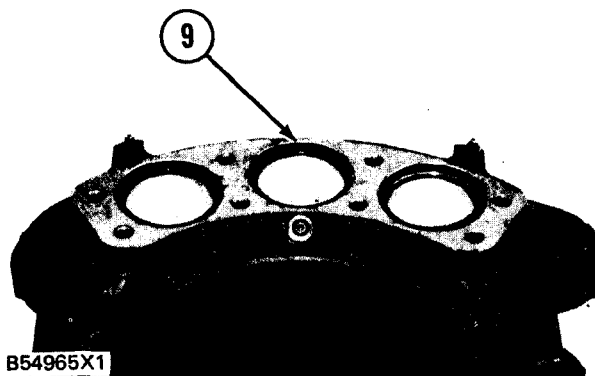

B54965X1

6. Install plate (6) on the brake head.

7. Put brake carriers (7) into position in the brake head. Install pins (9) that hold the carriers in place.

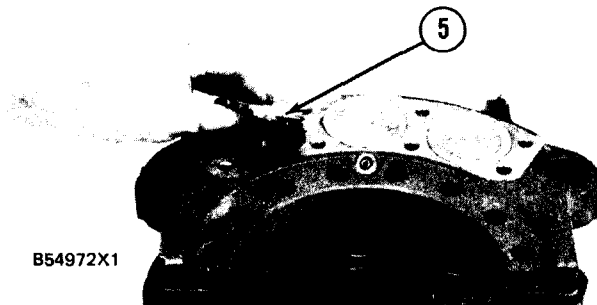

B54972X1

8. Install bolts (8) that hold the pins in place. Tighten the bolts to a torque of 45 ± 7 N·m (33 ± 5 lb.ft.).

end by:

a) install wheel brake assembly

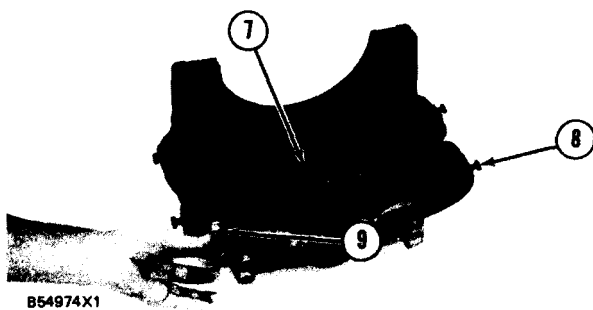

B54974X1

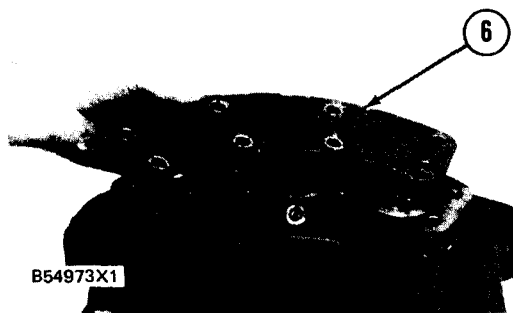

B54973X1

WHEEL SPINDLES

REMOVE WHEEL SPINDLES

4205-11

Tools Needed		A
6V2157	Link Bracket	1

start by:

a) remove wheels, bearings and duo-cone seals

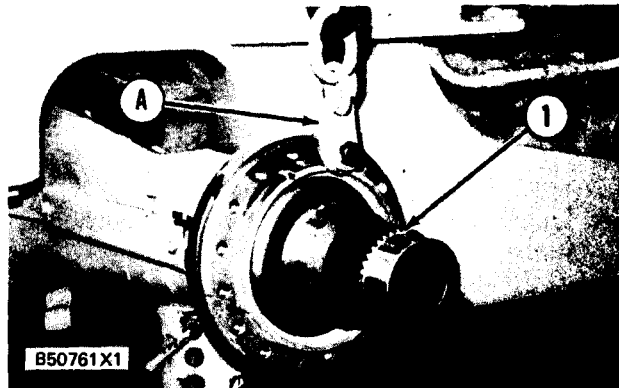

1. Fasten tool (A) and a hoist to spindle (1). Remove the bolts and spindle (1). The weight of the spindle is 27 kg (60 lb.).

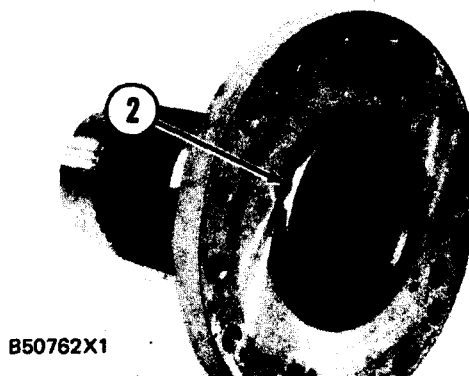

2. Remove O-ring seal (2) from the spindle.

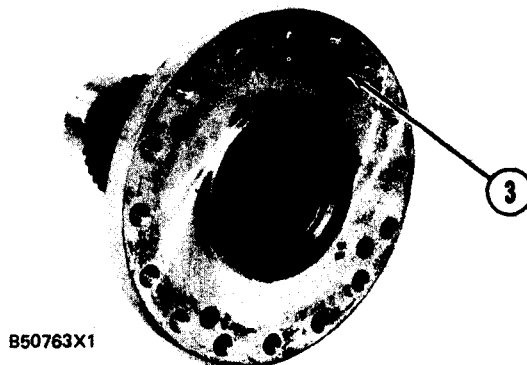

3. Remove bolts (3) and remove the retainer from the spindle.

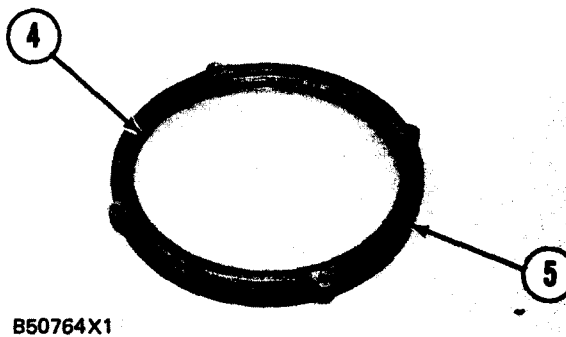

4. Remove O-ring seal (4) from retainer (5).

WHEEL SPINDLES

INSTALL WHEEL SPINDLES

4205-12

Tools Needed		A
6V2157	Link Bracket	1

1. Install O-ring seal (1) in position on retainer (2) as shown.

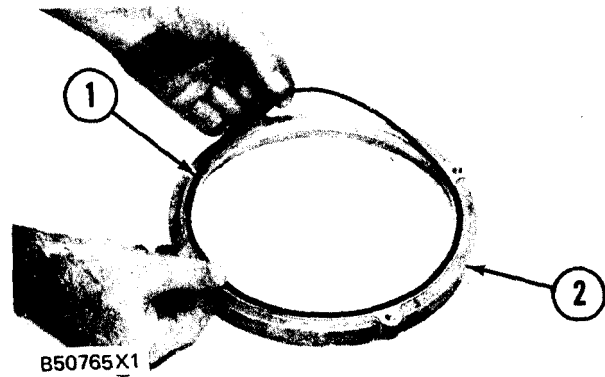

2. Install retainer (2) on spindle (3).

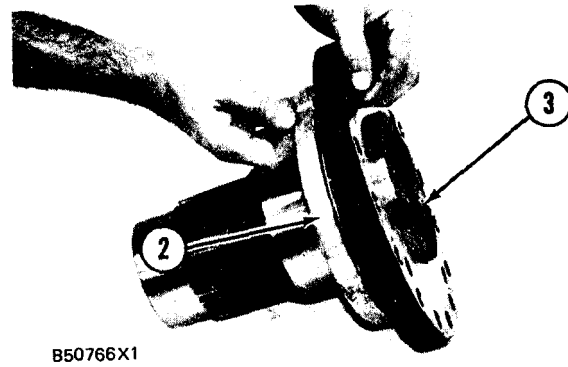

3. Install O-ring seal (4) on back of spindle (3) as shown.

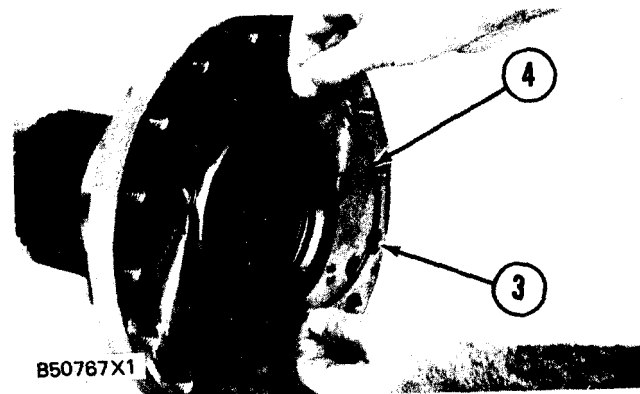

4. Fasten tool (A) and a hoist to spindle (3). Put the spindle in position on the axle housing and install the bolts. Tighten the bolts to a torque of 475 ± 50 N·m (350 ± 37 lb.ft.). end by:
 - a) install wheels, bearings and duo-cone seals

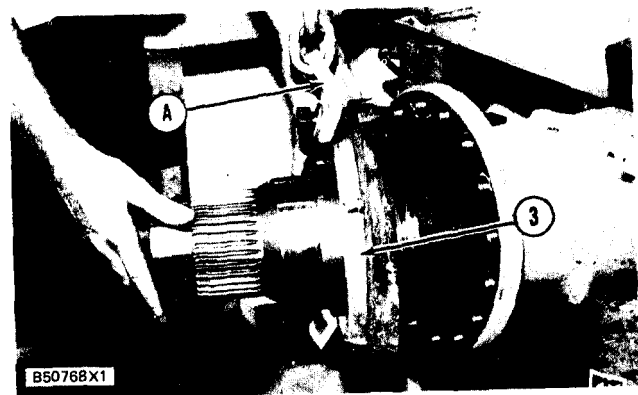

FRONT AXLE HOUSING

REMOVE FRONT AXLE HOUSING 3260-C-11

Tools Needed		A
8S7815	Pin	2
8S8048	Saddle	2
8S7630	Stand	2
8S7641	Tube	2

start by:

- a) remove tires and rims (front)
- b) remove front drive shaft

1. Lift the bucket and put tooling (A) in position under the lift arms as shown. This will permit access to the front axle bolts.
2. Disconnect brake line (1) from the junction box as shown.
3. Fasten straps (2) and hoist to front axle housing (3) as shown.
4. Remove nuts (4), the bolts and the washers. Carefully lower front axle housing from the machine. The weight of the axle housing is 953 kg (2100 lb.).

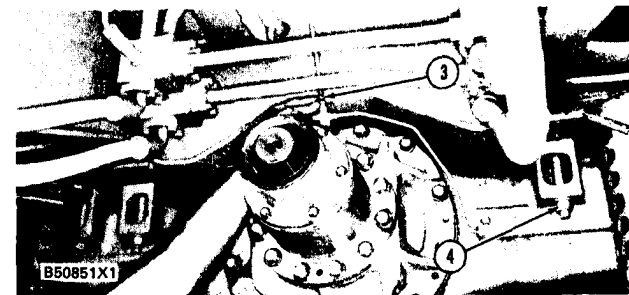
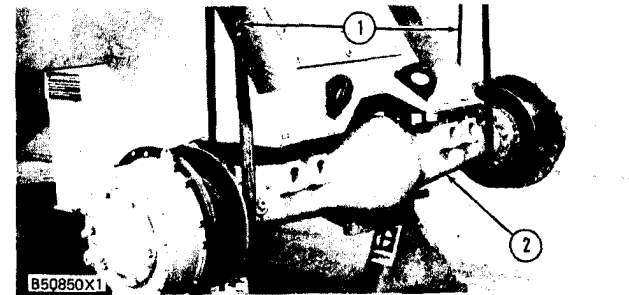
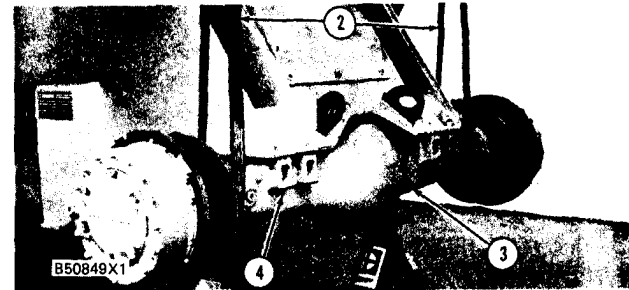
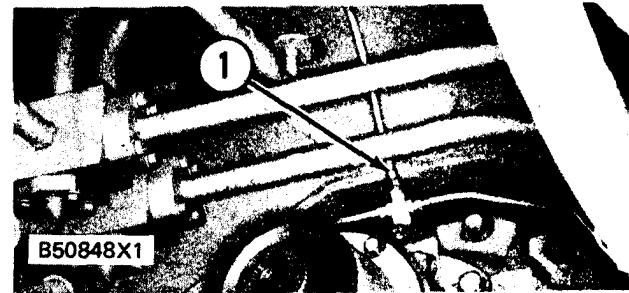
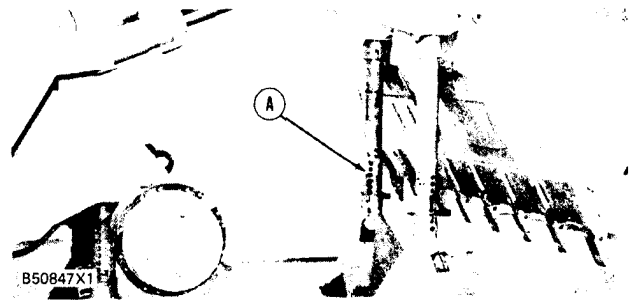

INSTALL FRONT AXLE HOUSING 3260-C-12

Tools Needed		A
8S7615	Pin	2
8S8048	Saddle	2
8S7630	Stand	2
8S7641	Tube	2

1. Fasten straps (1) and hoists to axle housing (2).
 2. Put axle housing (2) into position on the machine as shown.
 3. Install the bolts, the washers and nuts (4) that hold the axle housing to the machine. Tighten the nuts to a torque of 275 ± 35 N·m (200 ± 26 lb. ft.).
 4. Connect brake line (3) to the junction box. Remove (bleed) the air from the brake system.
 5. Remove tooling (A).
- end by:
- a) install tires and rims (front)
 - b) install front drive shaft

REAR AXLE HOUSING

REMOVE REAR AXLE HOUSING 3260-D-11

start by:

- a) remove tires and rims (rear)
- b) remove rear drive shaft

1. Disconnect brake line (1) from the top of axle housing.
2. Disconnect grease line (2) from the top of the rear support and the grease line from the top of the front support.
3. Fasten straps (3) and a hoist to rear axle housing (4) as shown.
4. Fasten a chain around the axle housing front support (6) and yoke (5) to hold front support (6) and yoke (5) in position.
5. Remove nuts (7) and the washers from both the front and rear supports.
6. Make sure all lines are disconnected and carefully lower the rear axle housing from the machine. The weight of the rear axle housing is 1089 kg (2400 lb.).

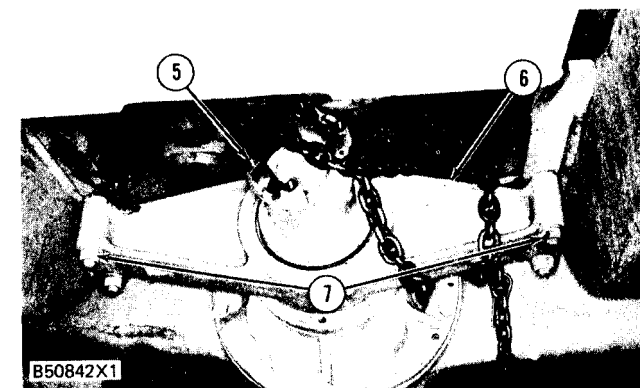
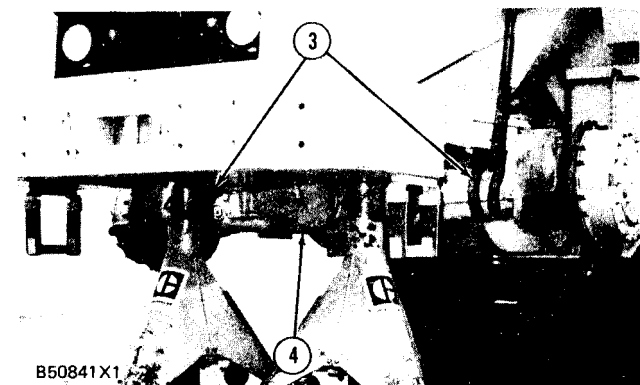
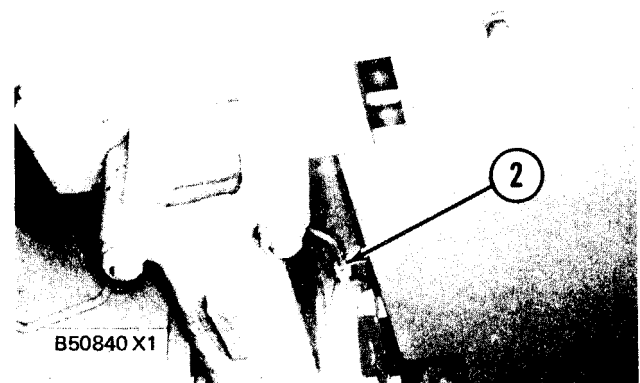
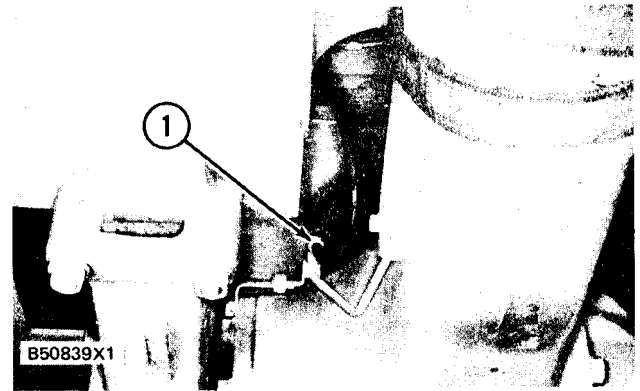

REAR AXLE HOUSING

INSTALL REAR AXLE HOUSING 3260-D-12

1. Fasten chain (2) as shown to front support (1) and yoke (3) to hold them in position.

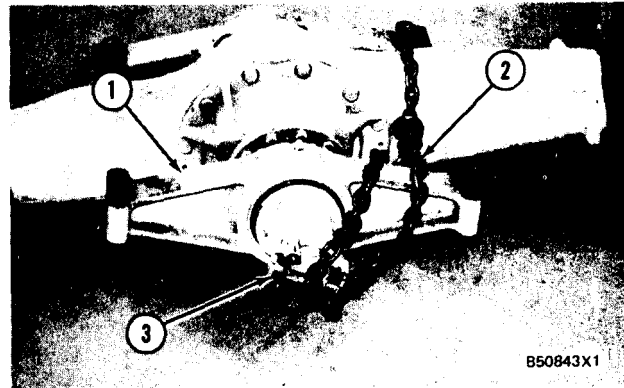

2. Put straps in position on both sides of the rear axle housing. Lift the axle housing into position on the machine.

3. Make sure the dowels in rear support (1) are in alignment with the holes in the frame.



4. Install the washers and nuts (4) to both supports. Tighten the nuts to a torque of 475 ± 50 N·m (350 ± 37 lb.ft.).

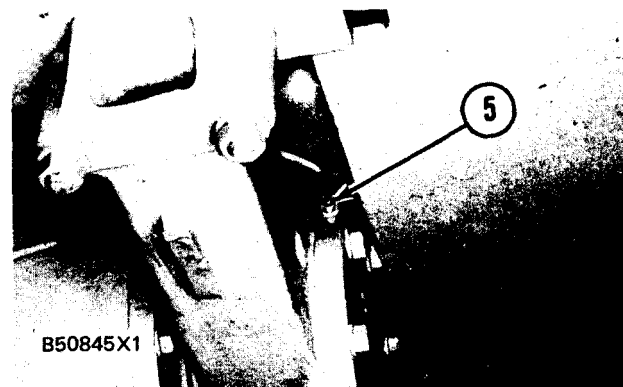

5. Connect grease fitting (5) to the rear support and the grease fitting to the top of the front support.

6. Connect brake line (6) at the top of the axle housing. Remove (bleed) the air from the brake system.

end by:

- a) install tires and rims
- b) install rear drive shaft

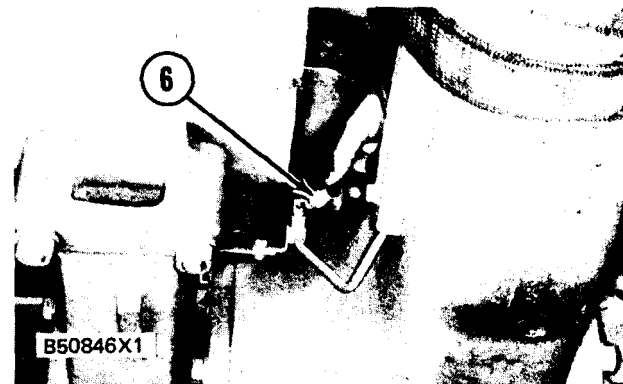

REAR AXLE HOUSING FRONT SUPPORT**REMOVE REAR AXLE HOUSING FRONT SUPPORT** 3271-11

1. Put the rear axle housing on blocks with the differential pinion shaft in a vertical position as shown.

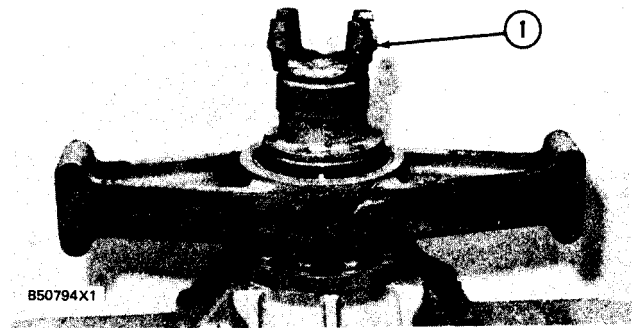

2. Pull yoke (1) off the differential pinion shaft.

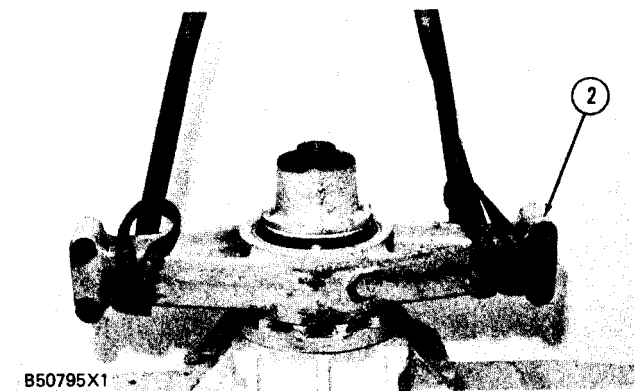

3. Fasten straps and a hoist and remove front support (2) from the differential pinion housing. The weight of front support (2) is 34 kg (75 lb.).

4. Remove lip type seal (3) from support (2).

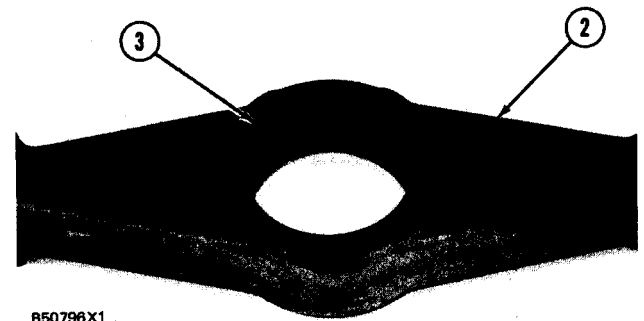

5. Remove ring (5) that holds bearing (4) in the support.

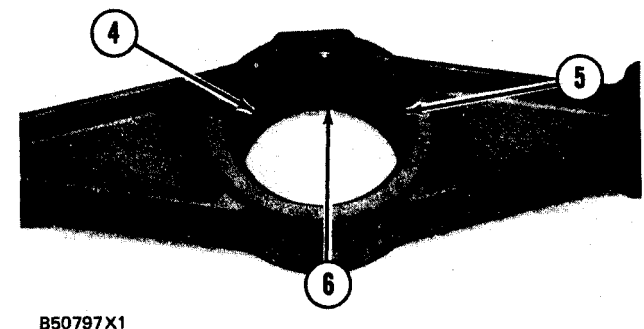

6. Remove lip type seal (6) and push bearing (4) out of the support from the same side ring (5) was removed.

REAR AXLE HOUSING FRONT SUPPORT

INSTALL REAR AXLE HOUSING FRONT SUPPORT 3271-12

Tools Needed		A	B
6V2086	Installer	1	
9S8874	Locator		1
1P520	Driver		1

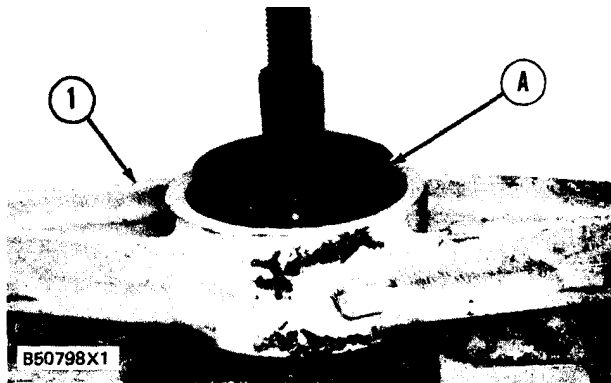

1. Use a press and tool (A) to push the bearing in support (1) until it makes contact with the shoulder in its bore.

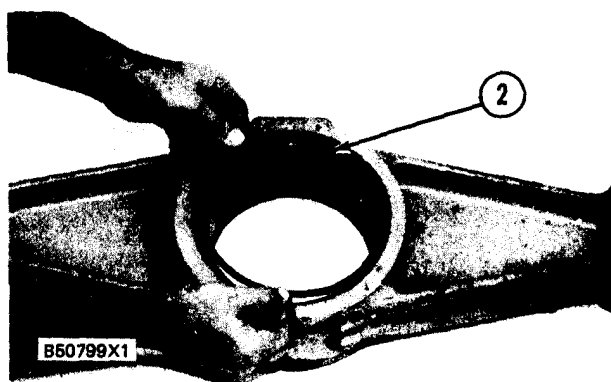

2. Install ring (2) to hold the bearing in position.

3. Use tooling (B) to install lip type seals (3) in each side of the support. Make sure the lips of the seals are toward the outside as shown.

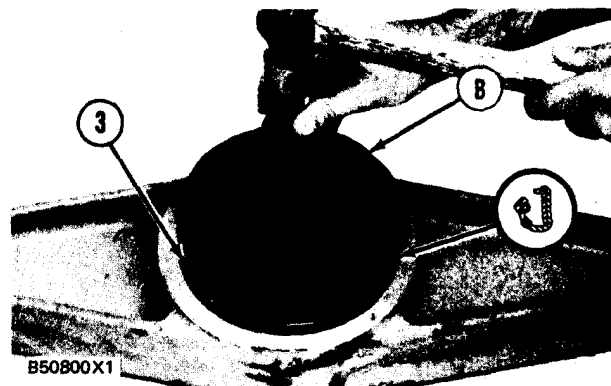

4. Fasten a hoist and put front support (1) in position on the differential pinion housing. Make sure the side of support (1) with the snap ring in it is toward the yoke end of the pinion shaft. The grease fitting in support (1) must be toward the top of the axle housing.

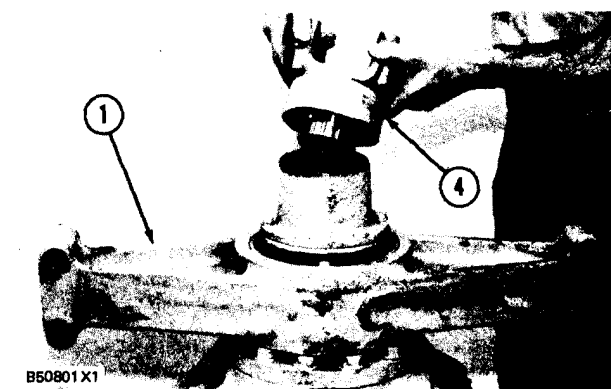

5. Install yoke (4) on the differential pinion shaft. end by:

- a) install rear axle housing

REAR AXLE HOUSING REAR SUPPORT**REMOVE REAR AXLE HOUSING REAR SUPPORT**

3271-11

Tools Needed		A
1P520	Driver Group	1

start by:

a) remove rear axle housing

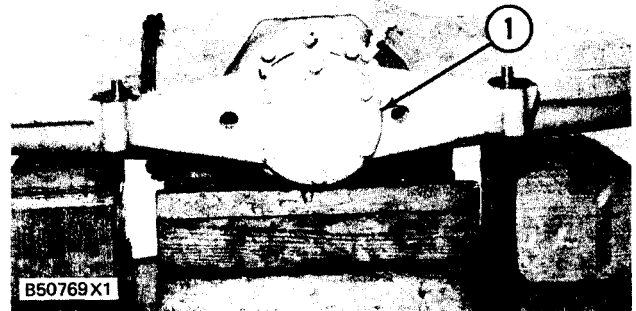

1. Put the rear axle housing on wooden blocks as shown.

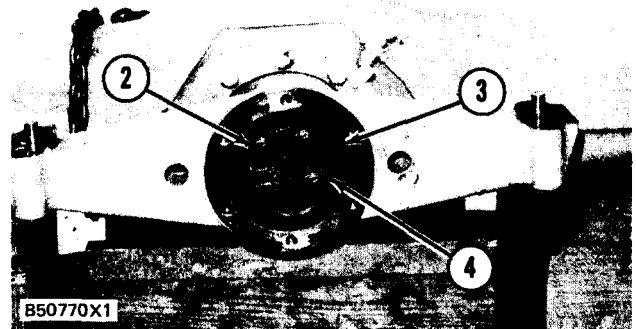

2. Remove the bolts and cover (1) from the rear support.

3. Remove bolts (2), washer (3), plate (4) and the washer from the end of the trunnion.

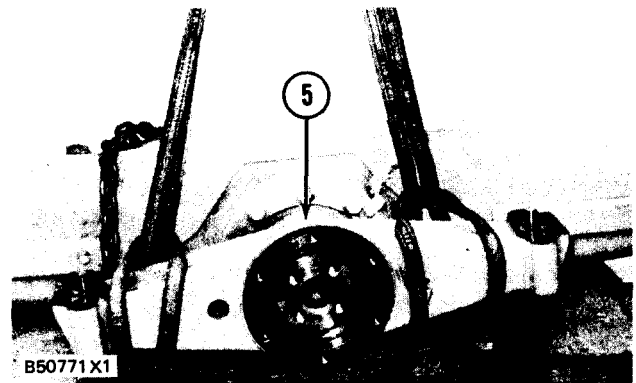

4. Fasten straps and a hoist to support (5) and remove it from the axle housing. The weight of the support is 39 kg (85 lb.).

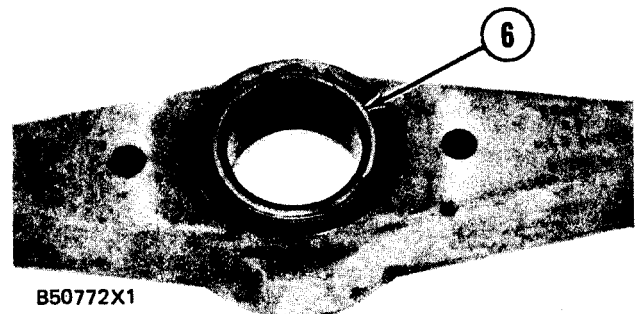

5. Remove seal (6) from the support.

REAR AXLE HOUSING REAR SUPPORT

6. Use tooling (A) and a press and remove the bearing from the support.

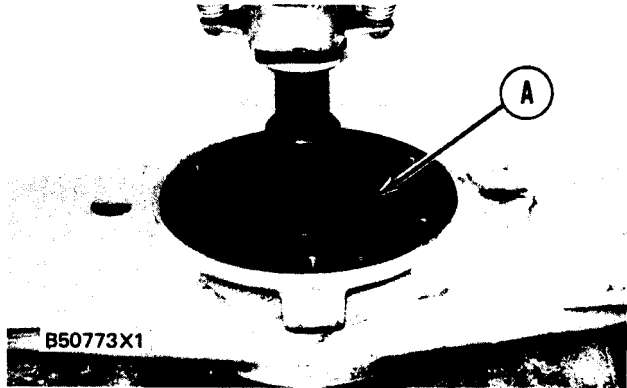

7. Remove the bolts and disconnect bracket (7) from the trunnion.

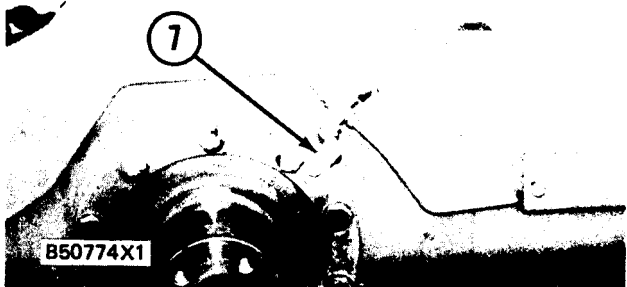

8. Remove the bolts and trunnion (8) from the rear axle housing.

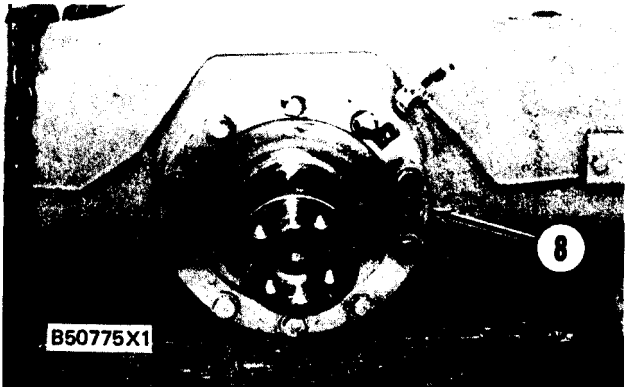

9. Remove O-ring seal (9) from the trunnion.

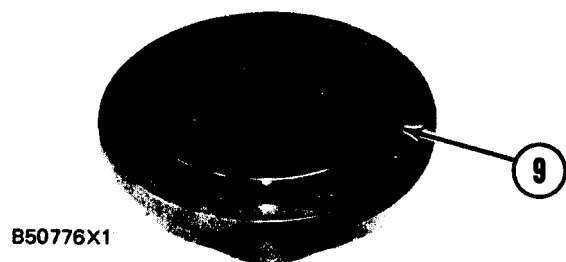

REAR AXLE HOUSING REAR SUPPORT

INSTALL REAR AXLE HOUSING REAR SUPPORT 3271-12

	Tools Needed	A
1P520	Driver Group	1

- Put O-ring seal (2) in position on trunnion (1) as shown. Put clean differential oil on the O-ring seal.

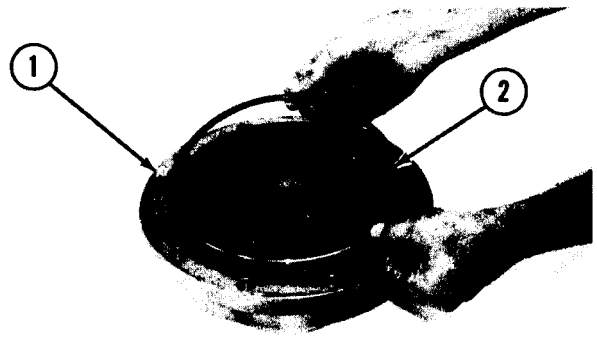

B50777X1

- Install trunnion (1) on the axle housing and install the bolts. Tighten the bolts to a torque of 270 ± 25 N-m (200 ± 18 lb. ft.).

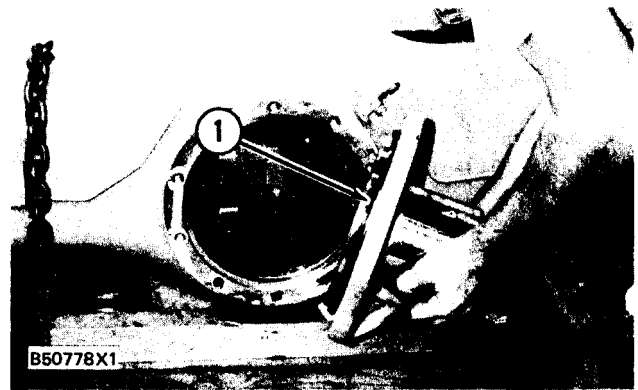

B50778X1

- Connect bracket (3) to the trunnion.

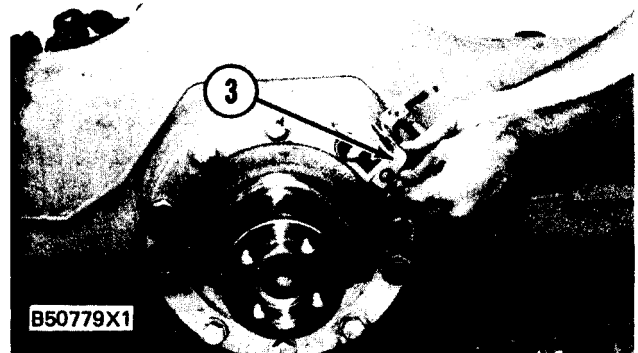

B50779X1

- Use tooling (A) and install the bearing until it is even with the counterbore in support (4).

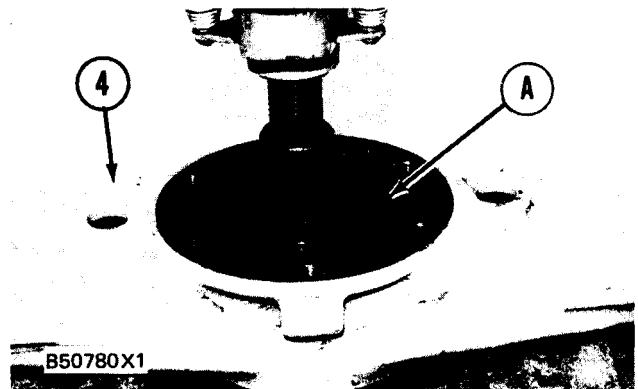

B50780X1

REAR AXLE HOUSING REAR SUPPORT

5. Use tool (A) and install the seal in the support. Make sure the lip of the seal is toward the outside as shown. Put clean differential oil on the seal.

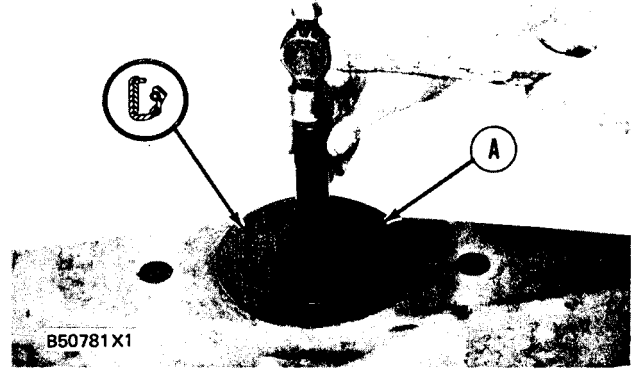

6. Fasten straps and a hoist to support (4) and put it in position on the trunnion.

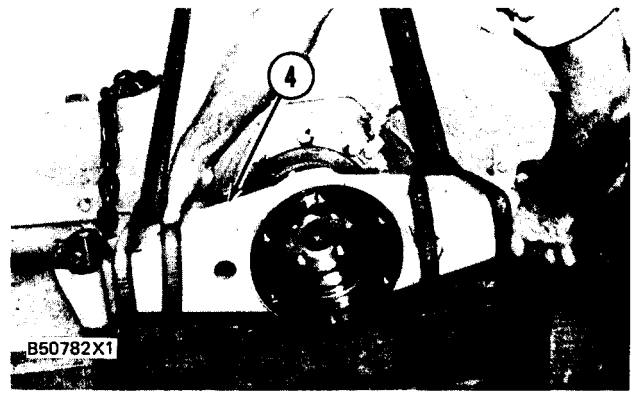

7. Install washer (5), plate (6) and washer (7) in the end of the support as shown.

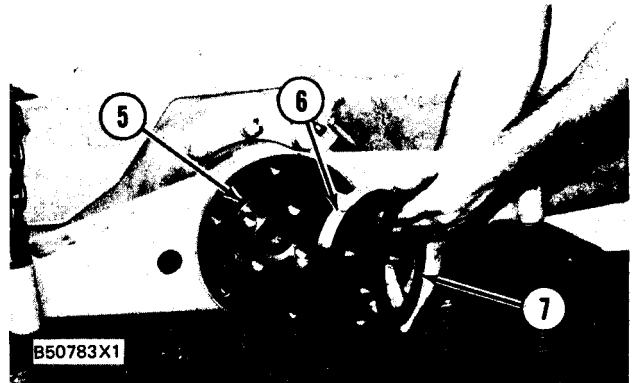

8. Install cover (8) and the bolts on the end of the support. Tighten the bolts to a torque of 475 ± 50 N·m (350 ± 37 lb.ft.).
end by:
a) install rear axle housing

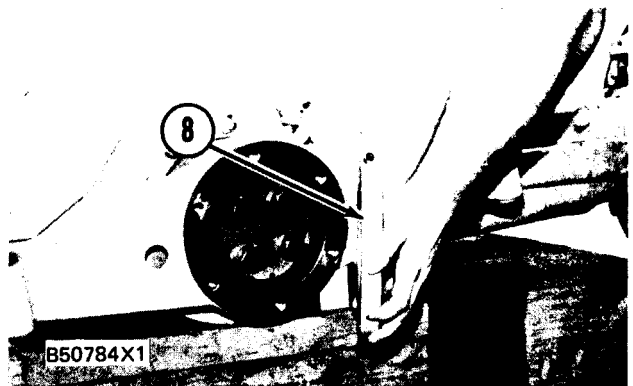

DRIVE SHAFT CARRIER BEARING

REMOVE DRIVE SHAFT CARRIER BEARING

3267-11

start by:

- a) remove parking brake*

*This operation is in the VEHICLE SYSTEMS DISASSEMBLY AND ASSEMBLY section.

1. Fasten a strap around front drive shaft (2) and the frame of the machine as support for the weight and to prevent damage to the drive shaft splines.
2. Disconnect grease line (1) from the fitting.
3. Disconnect grease line (1) from fitting (3) and remove it from the machine.
4. Remove the six nuts and bolts (4) that hold the carrier bearing housings in position.
5. Pull the carrier bearing and housings off the front drive shaft and remove the unit from the machine.
6. Remove bolts (6) that hold housings (5) and (7) together.
7. Remove housing (5) from housing (7). If necessary, use two 5/8"-11 NC x 1 3/4" long bolts through the threaded holes in housing (5) to make a separation of the housings.
8. Remove the lip type seal (8) from housing (5).

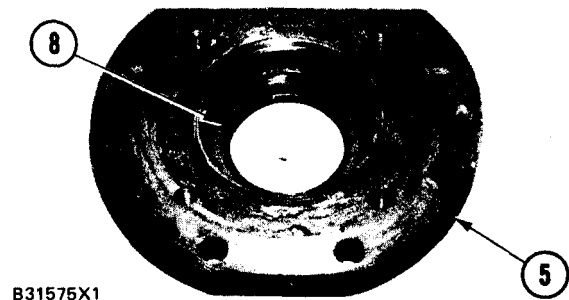
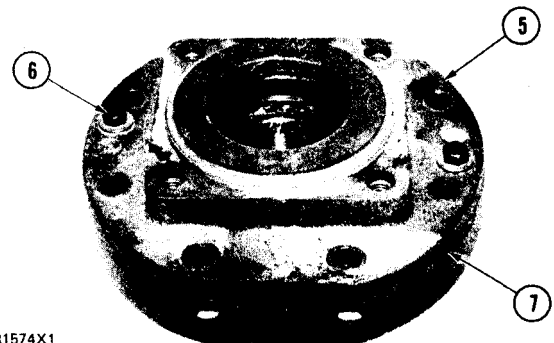
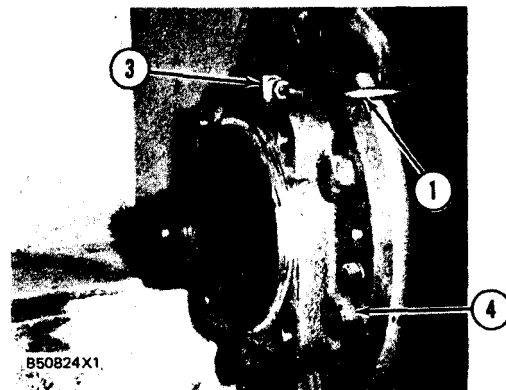
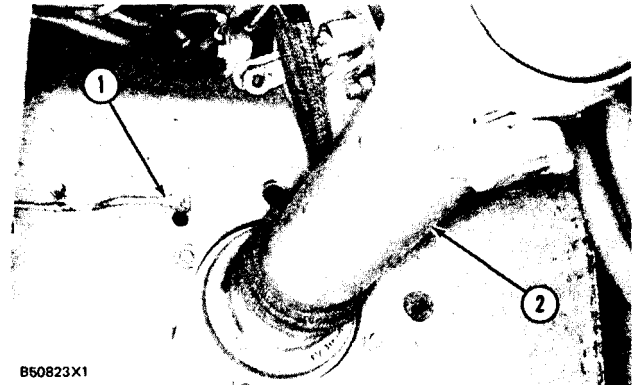

DRIVE SHAFT CARRIER BEARING

9. Remove O-ring seal (10) and bearing (9) from housing (7).

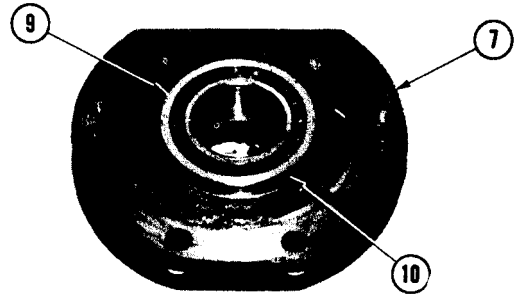

B31576X1

10. Remove lip type seal (11) from housing (7).

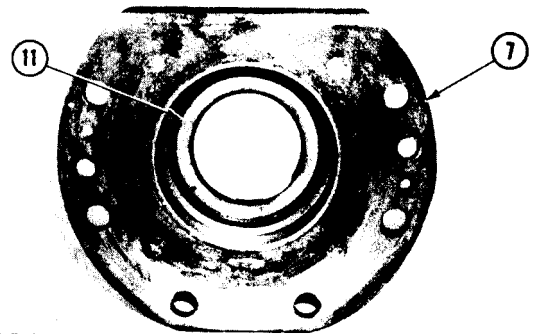

B31577X1

INSTALL DRIVE SHAFT CARRIER BEARING

3267-12

Tools Needed		A
1P520	Driver Group	1

NOTE: Models 950BS and 950BNS use a different type seal than models 950BSCE and 950BNSCE. Maintenance procedures shown here will work for all models.

1. Use tool group (A) to install the seal in housing (1). Make sure the lip of the seal is toward the outside as shown.

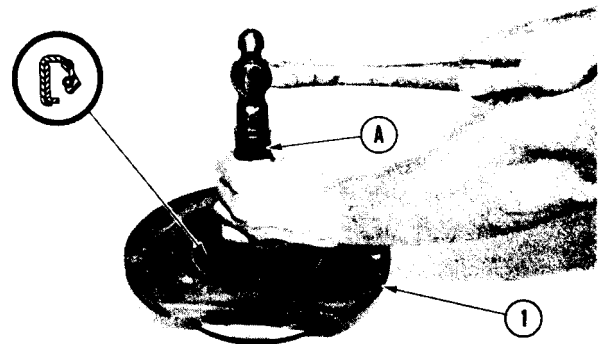

B31578X1

CAUTION

For models 950BNS and 950BS, both lip type seals for the carrier bearing housings must be installed so the lips of the seals are toward the front drive shaft at assembly to keep grease out of the parking brake.

2. Put clean grease on the lip of the seal and put housing (1) in position over the front drive shaft.

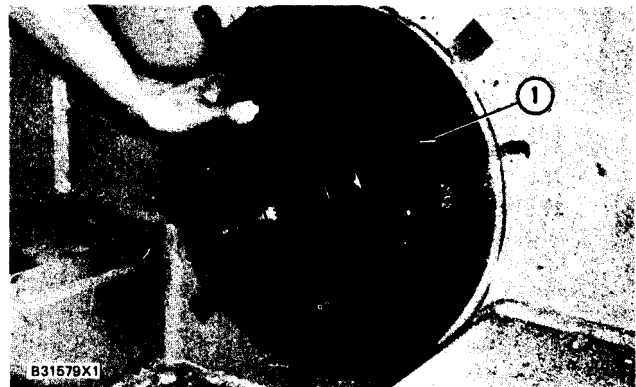

B31579X1

DRIVE SHAFT CARRIER BEARING

3. Install bearing (2) on the end of the front drive shaft.

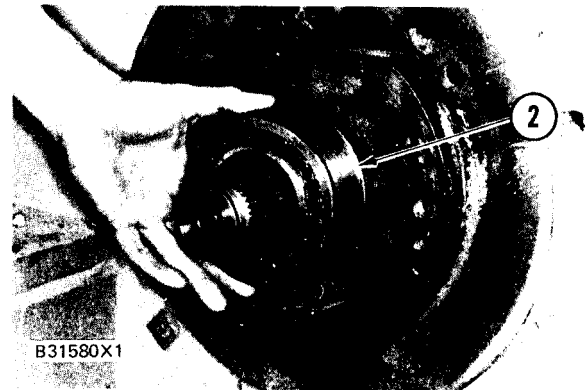

4. Put clean grease on O-ring seal (3) and install it around the bearing.

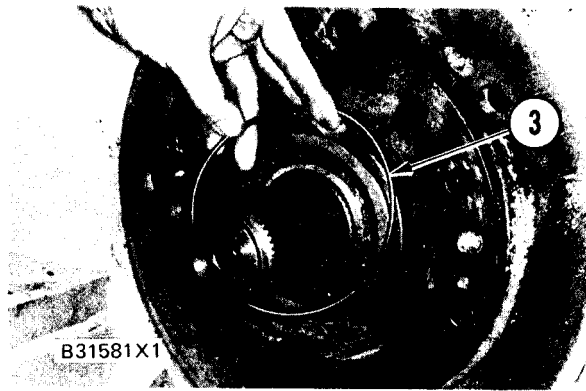

NOTE: Models 950BS and 950BNS use a different type seal than models 950BSCE and 950BNSCE. Maintenance procedures shown here will work for all models.

5. Use tool group (A) to install the seal in housing (4). For models 950BNS and 950BS, make sure the lip of the seal is toward the inside of the housing as shown.

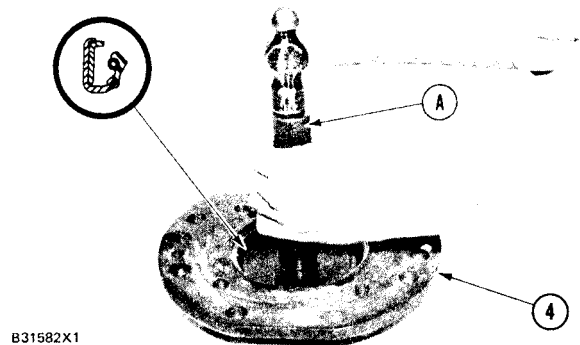

6. Put clean grease on the lip of the seal and install housing (4) over the end of the front drive shaft.



DRIVE SHAFT CARRIER BEARING

7. Install bolts (5) and the nuts to hold the carrier bearing and housings in position.

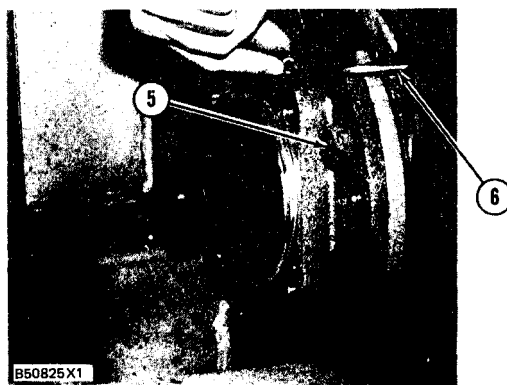

8. Put grease line (6) in position and connect it to the fittings on each side of the frame.

9. Install yoke (7) for the center drive shaft on the end of the front drive shaft.

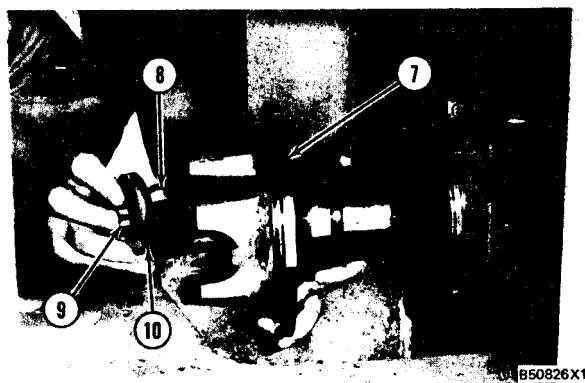

10. Install O-ring seal (8), retainer (10) and bolt (9) to hold the yoke.

11. Tighten bolt (9) to a torque of 135 ± 15 N-m (100 ± 11 lb. ft.).

12. Fill the carrier bearing housings with clean grease and make sure no grease comes out between the lip type seal and yoke into the parking brake area. If there is leakage of grease, a replacement of the lip type seal must be made in the carrier bearing housing.

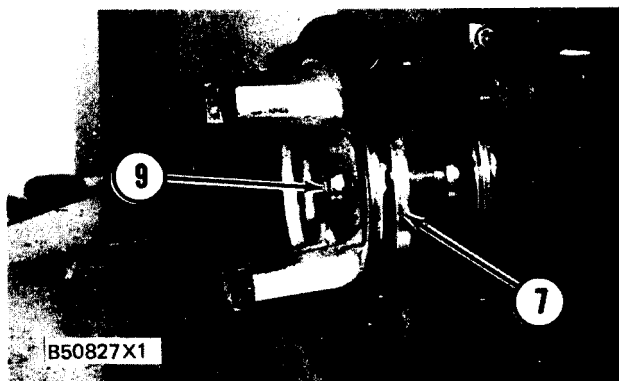

13. Remove yoke (7) from the end of the front drive shaft.

14. Remove strap (11) from front drive shaft (12).
end by:
a) install parking brake*

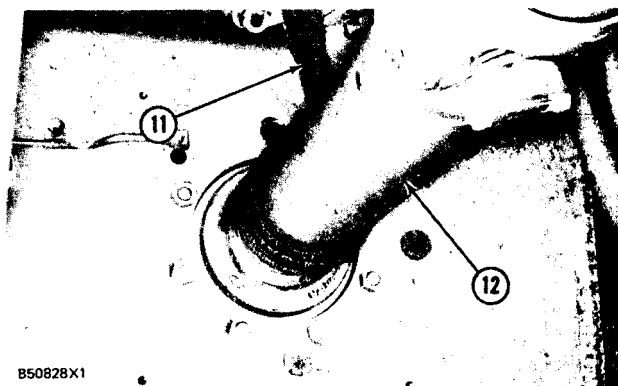

*This operation is in the VEHICLE SYSTEMS DISASSEMBLY AND ASSEMBLY section.

FRONT DRIVE SHAFT AND CENTER DRIVE SHAFT

REMOVE AND INSTALL FRONT DRIVE SHAFT

3253-C-10

start by:

- a) remove drive shaft carrier bearing

CAUTION

Be careful not to damage the carrier bearing surface on drive shaft (1) when it is lowered on the frame.

1. Remove the strap and lower the end of drive shaft (1) on the frame.
2. Pull drive shaft (1) and yoke (2) from the differential pinion shaft and lower the unit from the machine.
3. If necessary, remove bolts (3) and the straps to remove yoke (2) from the universal joint and drive shaft (1).

NOTE: The following steps are for installation. Make sure all drive shaft yokes are on the same centerline as shown on the illustration on Page 40.

4. Connect yoke (2) to the universal joint and drive shaft (1) with straps and bolts (3). Tighten bolts (3) to a torque of 55 ± 15 N·m (41 ± 11 lb.ft.).
 5. Put drive shaft (1) and the yoke in position in the frame and slide the yoke over the differential pinion shaft.
- end by:
- a) install drive shaft carrier bearing

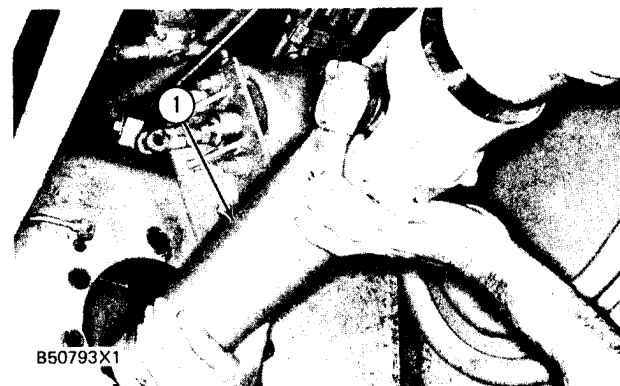
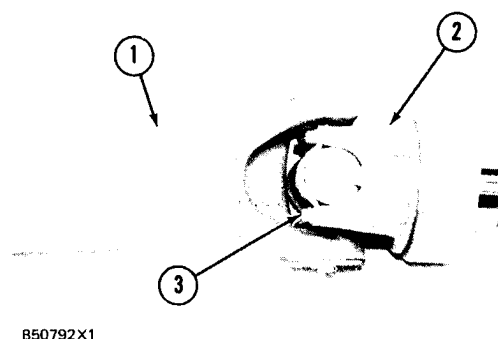
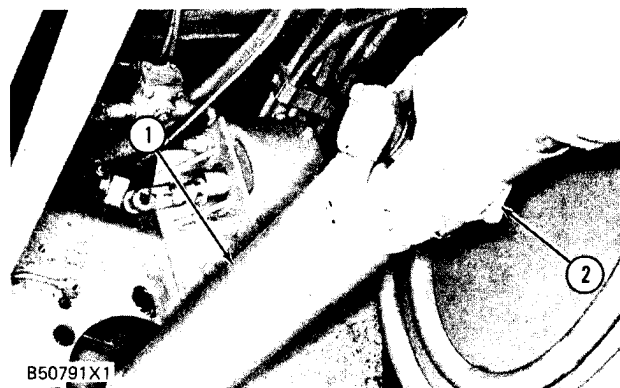

REMOVE INSTALL AND CENTER DRIVE SHAFT

3253-G-10

1. Make sure the parking brake is released so the drive shaft can be turned.
2. Remove bolts (3) and straps (2) from both ends of drive shaft (1) and remove it from the machine.

NOTE: Make sure all drive shaft yokes are on the same center line as shown on the illustration on Page 40.

3. Put drive shaft (1) in position and install straps (2) and bolts (3) as shown. Tighten bolts (3) to a torque of 55 ± 15 N·m (41 ± 11 lb. ft.).

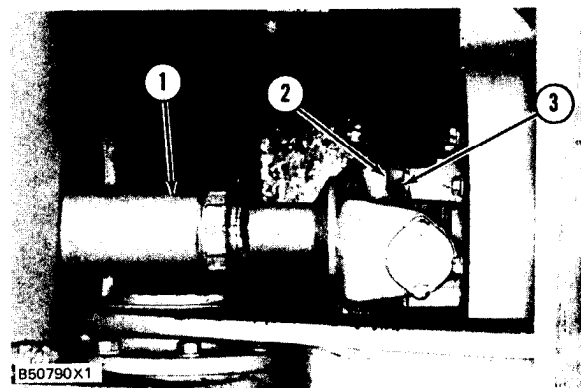

REAR DRIVE SHAFT

REMOVE REAR DRIVE SHAFT 3253-D-11

1. Remove bolts (1) and straps (3) that hold drive shaft (2) to the yokes. Remove drive shaft (2) from the machine.

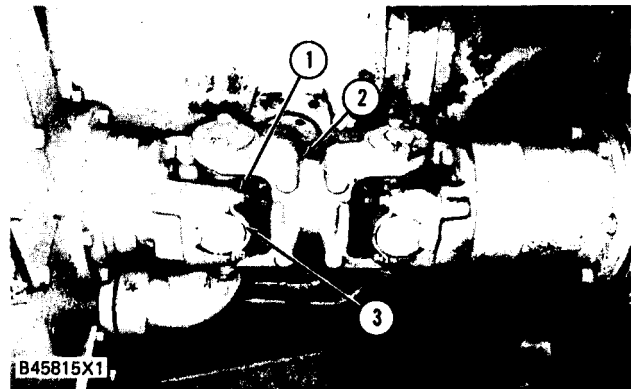

INSTALL REAR DRIVE SHAFT 3253-D-12

NOTE: Make sure all drive shaft yokes are on the same center line as shown on the illustration below.

1. Put drive shaft(1) in position. Install the straps and bolts to hold drive shaft (1) to the yokes. **Tighten bolts to a torque of 55 + 15 N-m (41 + 11 lb.ft).**



B32281X1

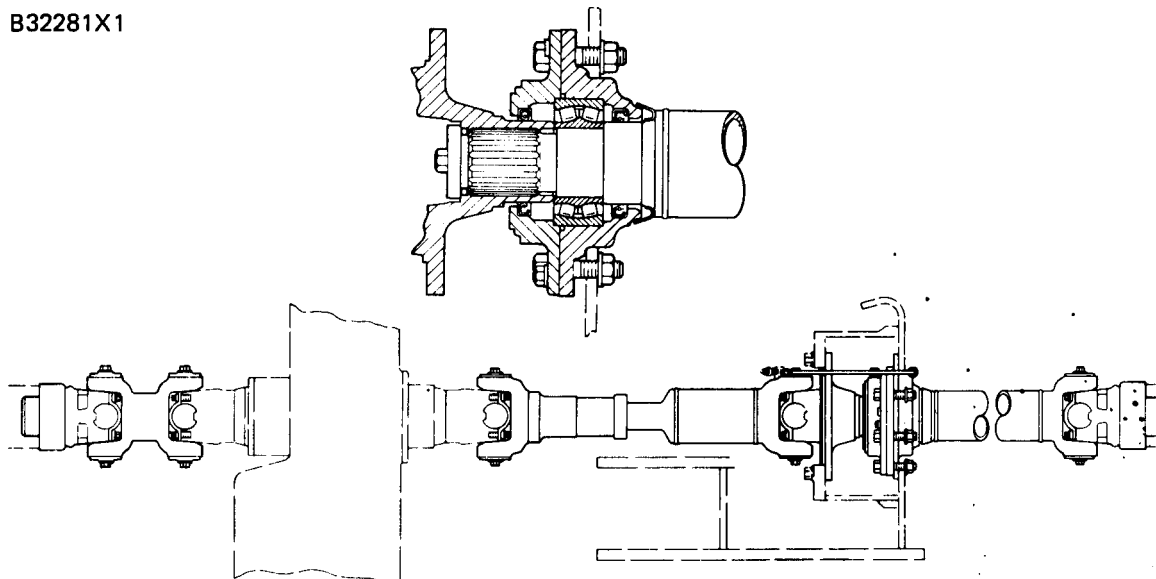

STANDARD DEFERENTIAL

REMOVE STANDARD DIFFERENTIAL

3258-C-11

Tools Needed	A
OTC Model 1790 Transmission Jack	1

start by:

- a) remove front drive shaft
- b) remove drive axles (front)

1. Drain the oil from the front axle housing.
2. Remove the bolts and brake line guards (3) from both sides of the axle housing.
3. Remove brake lines (2) and (4) from the machine.
4. Remove the bolt and nut and tee bracket (1) from the machine.
5. Fasten tool (A) to differential (5) as shown.
6. Remove the bolts and use two ½"-13 NC forcing screws to loosen differential from the axle housing.
7. Remove the differential from the machine. The weight of the differential is 204 kg (450 lb.).

NOTE: It can be necessary to make an adjustment to tool (A) to remove the differential from under the machine.

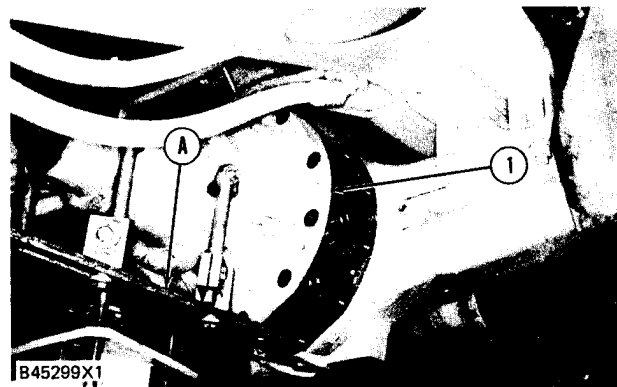
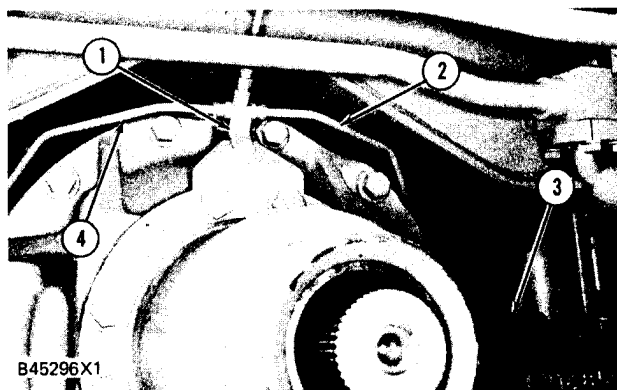

INSTALL STANDARD DIFFERENTIAL

3258-C-12

Tools Needed	A
OTC 1790 Transmission Jack	1

1. Fasten differential (1) to tool (A) as shown.
2. Make sure the O-ring seal is installed around the differential carrier and put clean oil on it.
3. Put differential (1) in position in the front axle housing. If necessary use two ¾"- 10 NC guide bolts to keep the differential in alignment.
4. Install bolts (6) and tighten them to a torque of 270 ± 25 N-m (200 ± 20 lb. ft.).
5. Install tee bracket (2) on the differential.
6. Install brake lines (3) and (4). Remove (bleed) the air from the brake system.
7. Install brake line guards (5).
8. Fill the axle housing and final drives with clean oil.

end by:

- a) install axles (front)
- b) install front drive shaft

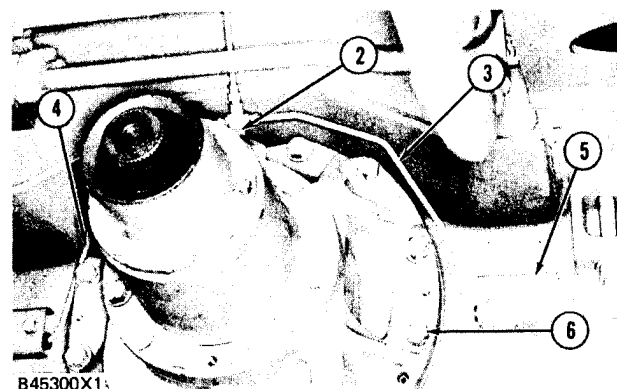

NO-SPIN DIFFERENTIAL

REMOVE NO-SPIN DIFFERENTIAL 3258-D-11

Tools Needed		A
5P9736	Link Bracket	1

start by:

- a) remove rear axle housing front support
- b) remove axles (rear)

1. Remove bolts (1) that hold the differential to the axle housing.
2. Fasten tool (A) to differential (3) and remove it from the axle housing. The weight of the differential is 150 kg (330 lb.).

NOTE: Two ½"-13 NC forcing screws (27) can be used to loosen differential (3) from the axle housing.

3. Remove O-ring seal (4) from the differential.

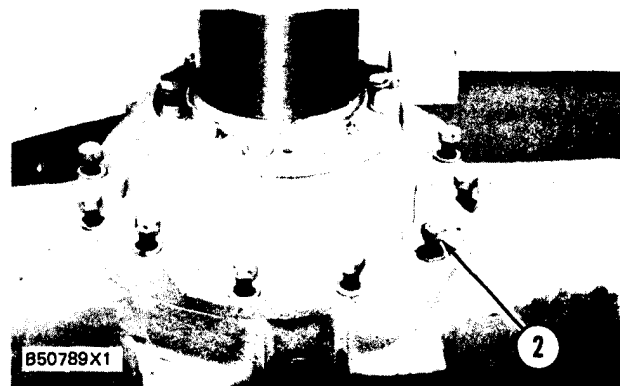
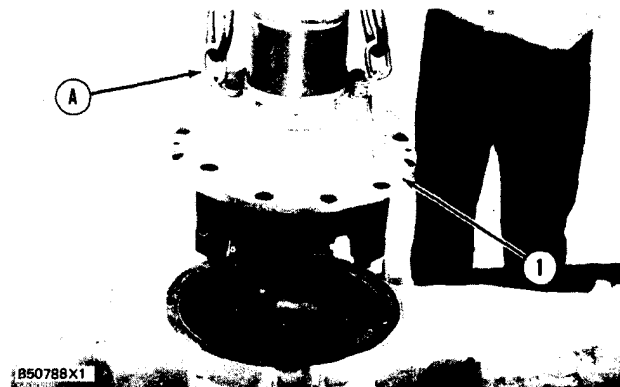
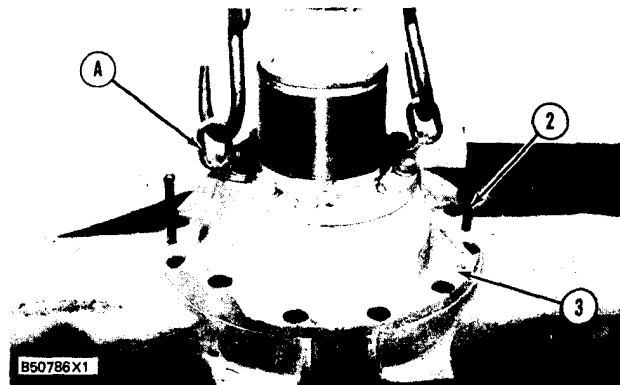
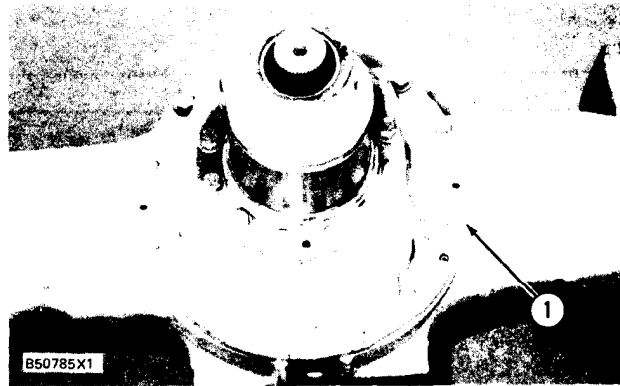
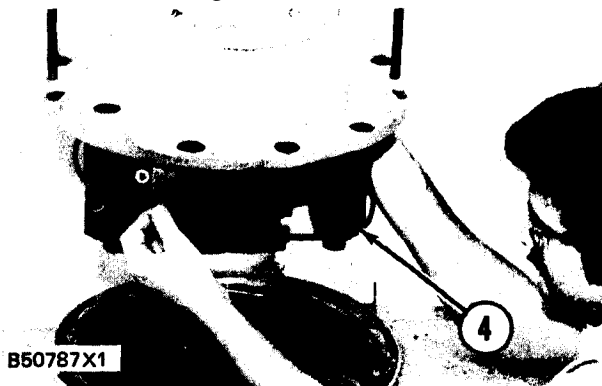

INSTALL NO-SPIN DIFFERENTIAL 3258-D-12

Tools Needed		A
5P9736	Link Bracket	1

1. Make sure the O-ring seal is installed around the differential and put clean oil on it.
 2. Fasten tool (A) and a hoist to differential (1) as shown.
 3. Put differential (1) in position in the outer housing with the bevel gear toward the right hand wheel assembly.
 4. Install bolts (2) and tighten them to a torque of 270 ± 25 N-m (200 ± 18 lb. ft.).
- end by:
- a) install rear axle housing front support
 - b) install axles (rear)

FRONT AND REAR DIFFERENTIALS

DISASSEMBLE FRONT AND REAR DIFFERENTIALS

3258-15

Tools Needed		A	B	C	D	E	F
1P2420	Transmission Repair Stand	1					
FT957	Adapter Group	1					
FT996	Positioning Group	1					
6V2156	Link Bracket	2					
6V4070	Spanner Wrench		1				
8B7548	Puller Assembly			1			
8B7557	Adapter		2				
8H684	Ratchet Box Wrench			1			
8B7560	Step Plate			1			
1P820	Hydraulic Puller Group				1	1	
5P3100	Pump Group (or electric)				1		
1B4207	Nut			2	2		
3H465	Plate			4	4		
8B7551	Bearing Puller Attachment			1	1		
5P4170	Step Plate			1	1		
5 F 7 3 6 9	Leg				2		
8B7549	Leg					2	

start by:

a) remove front or rear differential

1. Put the differential and carrier assembly on tooling (A) with the bevel gear down as shown.
2. Remove retainer (1) from pinion housing (2).
3. Remove lip type seal (3) from retainer (1).
4. Remove the bolts that hold housing (2) to the carrier assembly. Fasten a hoist to housing (2) with tooling (B).
5. Use two ½"-13 NC forcing screws and loosen housing (2) from the carrier assembly. Remove housing (2) and pinion from the carrier assembly. The weight of the unit is 41 kg (90 lb.).

NOTE: Models 950BNSCE and 950BSCE use a nut and keyed washer, rather than two nuts and a lock.

6. Bend the tab of the lock from nut (4). Install tool (C) and remove nut (4), the lock and nut (5) from the pinion shaft.

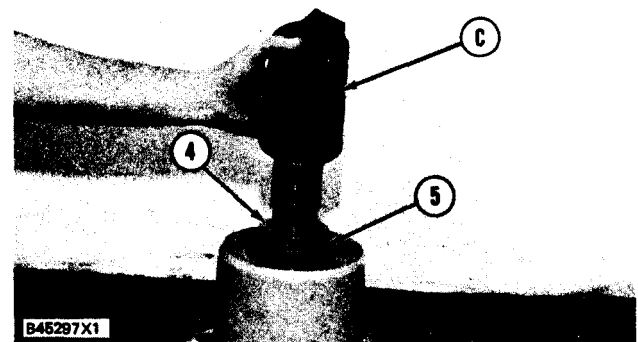
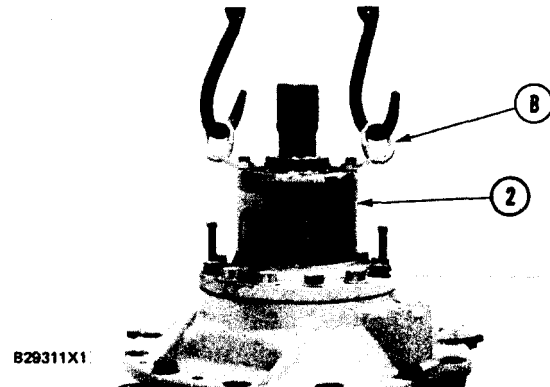
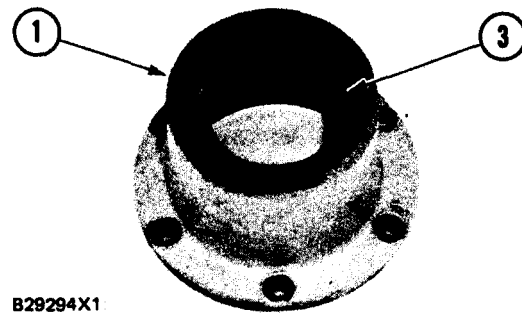
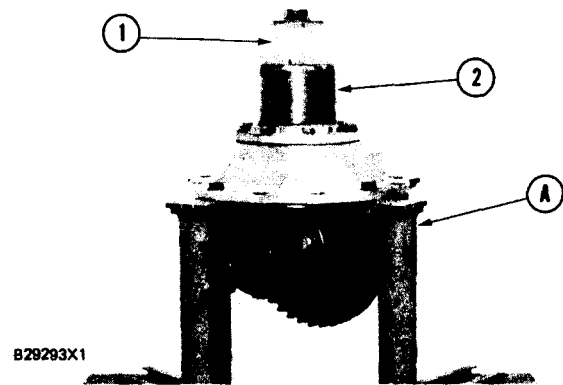

FRONT AND REAR DIFFERENTIALS

7. Use tooling (D) to push pinion shaft (6) out of housing (2).

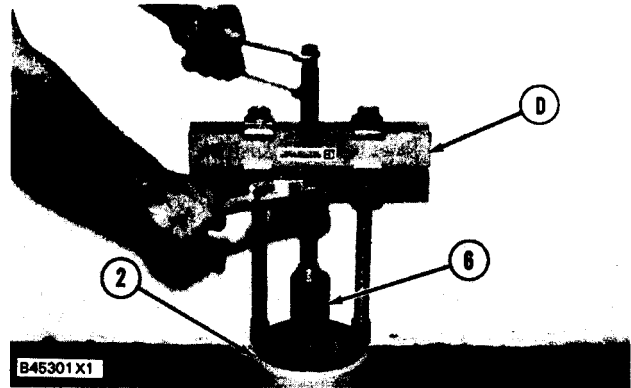

8. Remove bearing cone (7) from pinion shaft (6).

9. Remove bearing cone (8) from housing (2).



10. If necessary, remove bearing cup (9) from housing (2).

11. Remove O-ring seal (11) from housing (2).

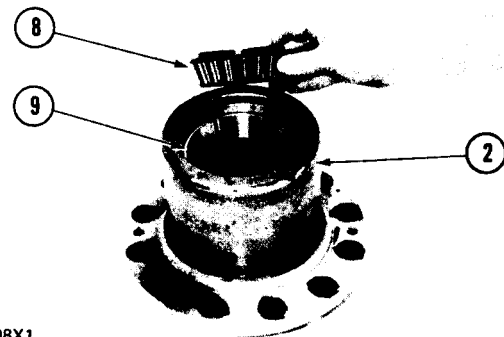

12. If necessary, remove bearing cup (10) from housing (2).

13. Remove locks (12) from bearing caps (13) and (14).

B29298X1

14. Remove the bolts and bearing caps (13) and (14) from the carrier assembly.

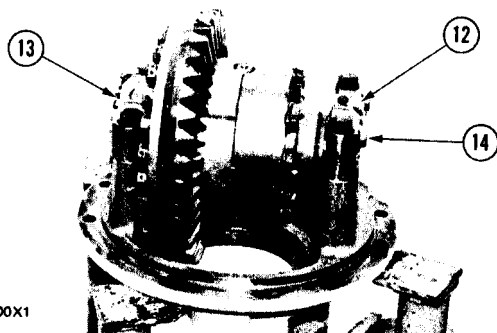

B29300X1

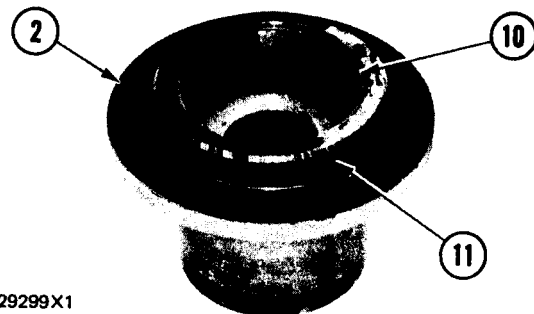

B29299X1

FRONT AND REAR DIFFERENTIALS

15. Slide a piece of pipe through the differential as shown. Fasten a hoist to the pipe. Remove the differential from the carrier assembly. The weight of the differential is 86 kg (190 lb.).

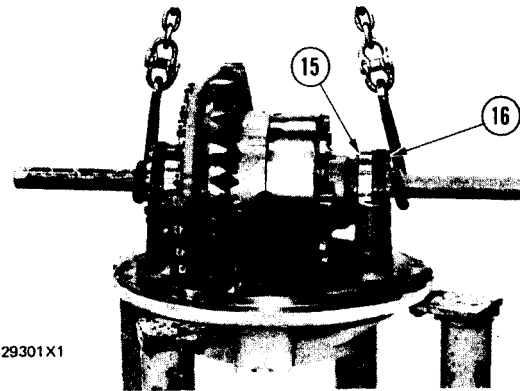

16. Remove rings (16) and bearing cups (15) from each end of the differential.

17. Use tooling (E) to remove bearing cone (17) from the differential.

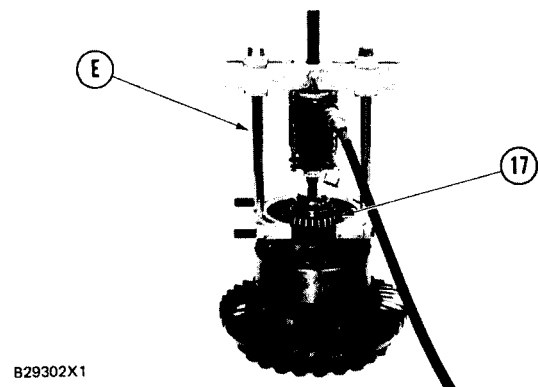

18. Put a mark on case (19) as to its location on the lower case for correct assembly. Remove bolts (18) and case (19) from the case and spider gears.

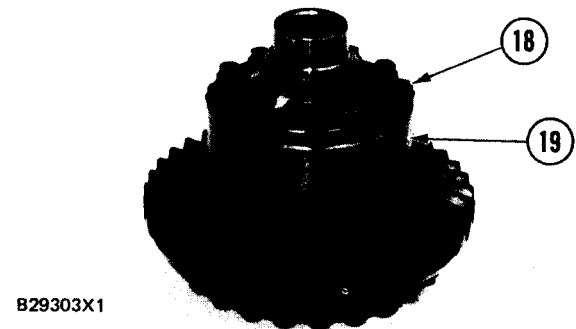

19. Remove washer (20) from gear (21). Remove gear (21) from the spider gears.

20. Remove spider (22) from the differential case.

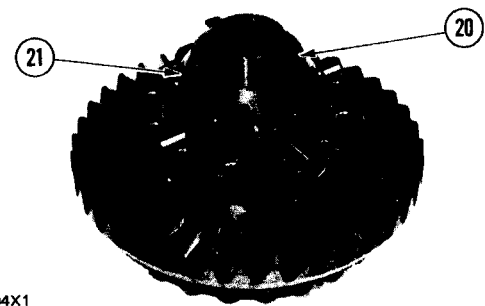
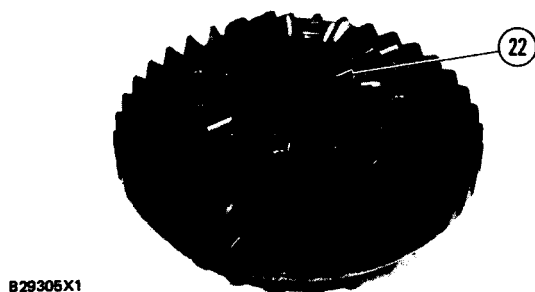

FRONT AND REAR DIFFERENTIALS

21. Remove washers (23) and gears (24) from spider (22).

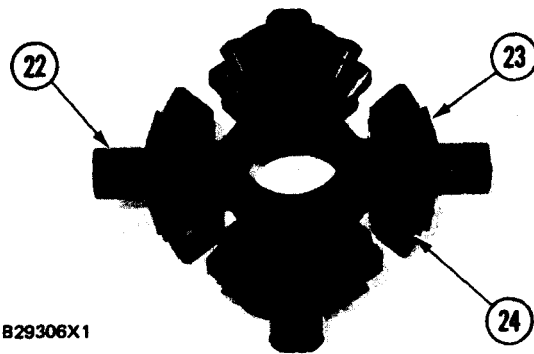

22. Remove gear (26) and the washer under it from case (25).

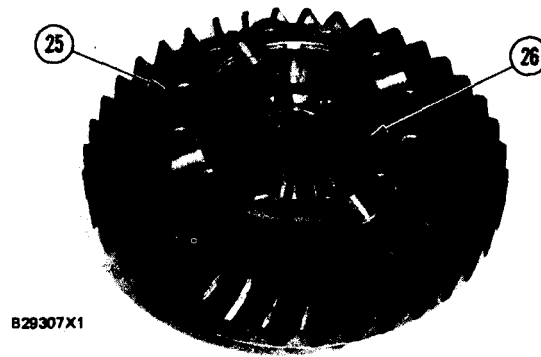

23. Remove the lockwire and bolts (27) that hold bevel gear (28) to case (25).

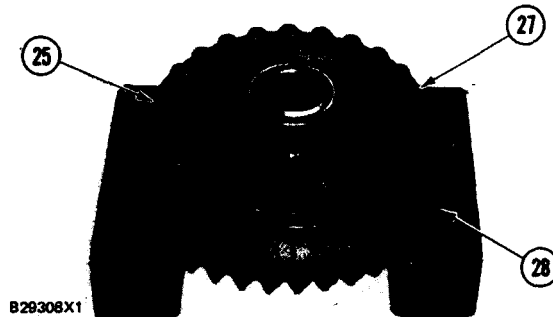

24. Fasten a hoist to case (25) and remove it from bevel gear (28). The weight of case (25) is 27 kg (60 lb.).

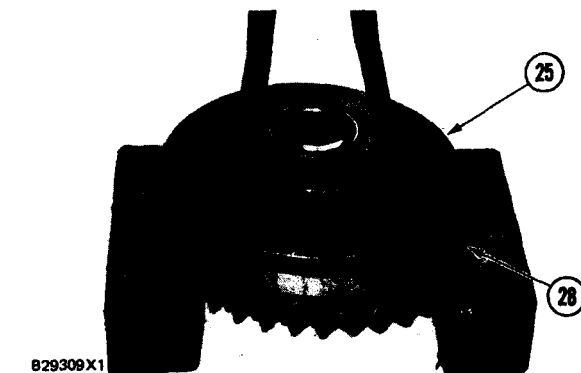

25. Use tooling (F) to remove bearing cone (29) from case (25).

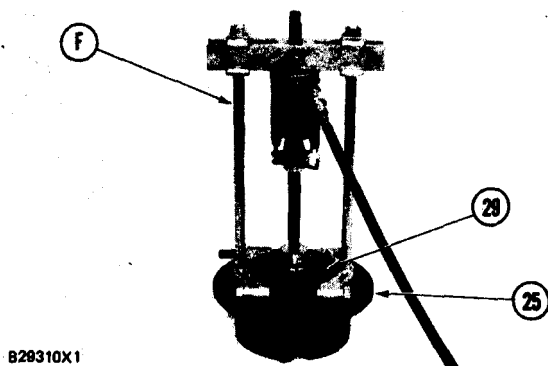

FRONT AND REAR DIFFERENTIALS

ASSEMBLE FRONT AND REAR DIFFERENTIALS

3258-16

Tools	Needed	A	B	C	D	E
1P2420	Repair Stand	1				
FT957	Adapter	1				
FT996	Positioning Group	1				
5P9736	Link Bracket		2			
1P520	Driver Group			1		
8S2328	Dial Test Indicator Group				1	
6V4070	Spanner Wrench					1

1. Heat the bearing to a maximum temperature of 1350 C (2750 F). Install bearing cone (1) on the differential case as shown.

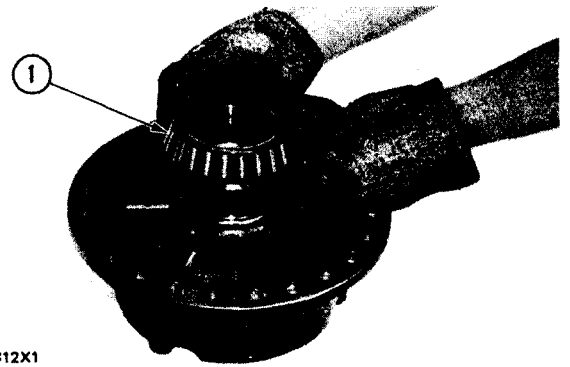

B29312X1

2. Install two 5/8"-18 NF guide pins in the bevel gear as shown. Fasten a hoist to case (2). Put case (2) in position in bevel gear (3). Install the bolts that hold it. Tighten the bolts to a torque of 135 +15 N-m (100 + 11 lb. ft.). Install the lockwire on the bolts.

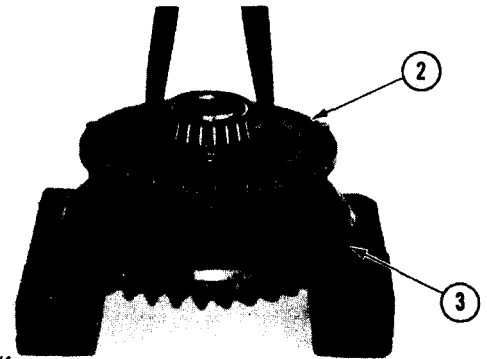

B29313X1

3. Install washer (5) and gear (4) in the case.

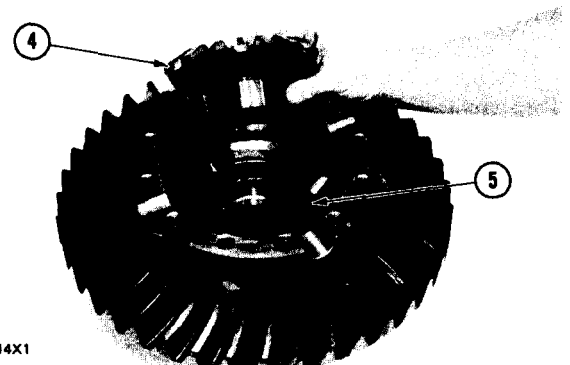

B29314X1

4. Install gears (7) and washers (6) on spider (8).

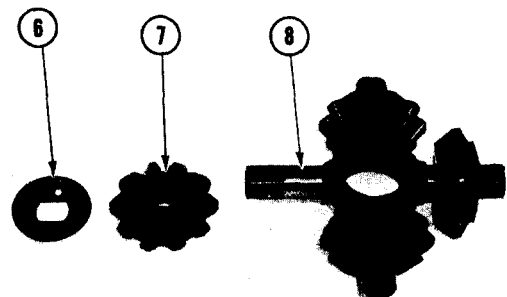

B29315X1

FRONT AND REAR DIFFERENTIALS

5. Install the gears and spider (8) in the case.



B29316X1

6. Install washer (9) on gear (10) and put the gear in position in the case.



B29317X1

7. Install case (11) on case (2). Make sure the marks on the cases are in alignment, and install the bolts that hold the cases together. Tighten the bolts to a torque of 135 ± 15 N-m (100 ± 11 lb.ft.).

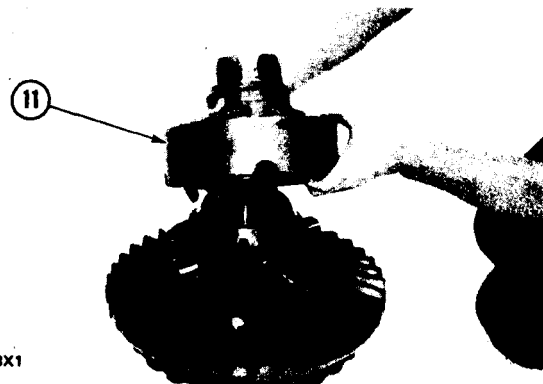

B29318X1

8. Heat the bearing cone to a maximum temperature of 135°C (275°F). Install bearing cone (12) on the case.

NOTE: There are differences between models of the Loader in this procedure. Those places where there are differences are annotated in the text.

9. Put carrier assembly (13) in position on tooling (A) as shown.

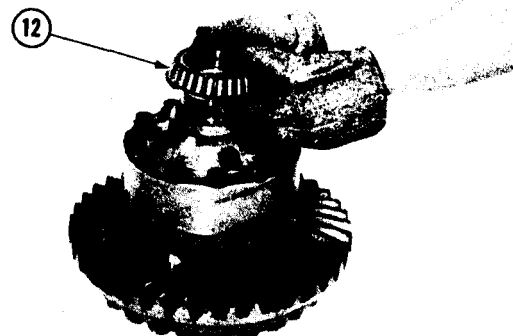

B29319X1

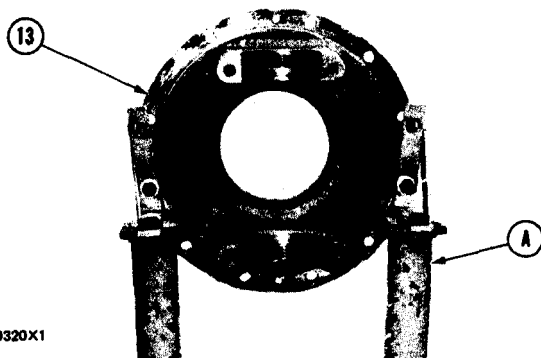

B29320X1

FRONT AND REAR DIFFERENTIALS

10. Install the larger bearing cap (16) on carrier assembly (13). Make sure the threads in the bearing cap and carrier assembly are in alignment before the bolts are tightened to 475 ± 50 N-m (350 ± 37 lb.ft).

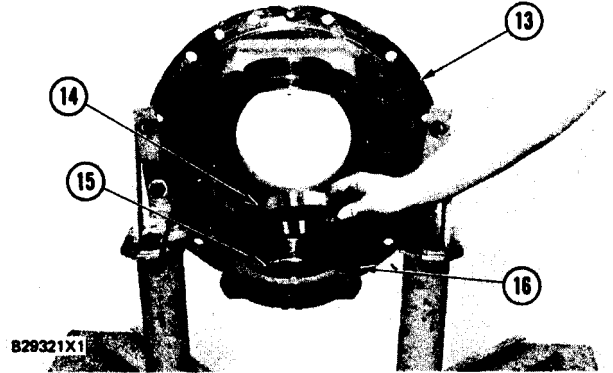

11. Install adjustment nut (15) and bearing cup (14) as shown.

12. Fasten a hoist to differential (17) with tooling (B). Put differential (17) in position in the carrier assembly as shown.

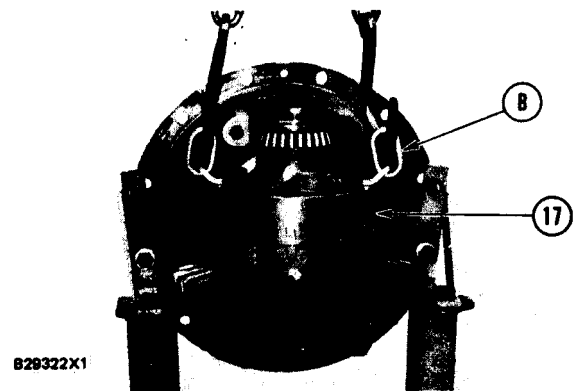

13. Install smaller bearing cap (19) on the carrier assembly. Make sure the threads in cap (19) and the carrier assembly are in alignment before the bolts are tightened to 475 ± 50 N-m (350 ± 37 lb.ft).

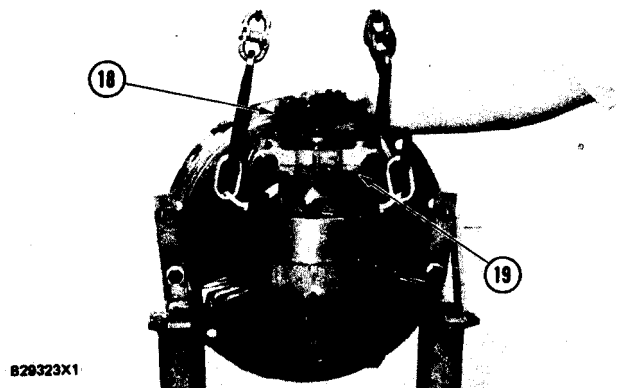

14. Install the bearing cup and adjustment nut (18).

15. Install inner bearing cup (20), outer bearing cup in pinion housing (21) using tool group C.

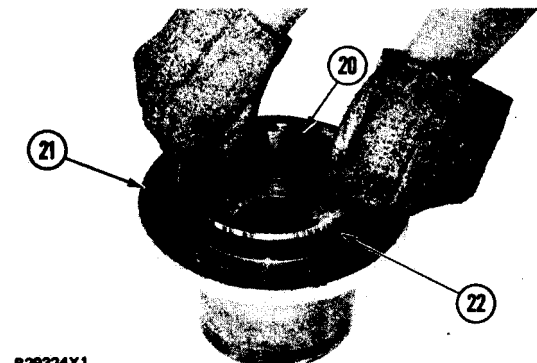

16. Install O-ring seal (22) on housing (21) and put clean oil on it.

FRONT AND REAR DIFFERENTIALS

17. Heat bearing cone (24) to a maximum temperature of 135°C (275°F). Install bearing (24)
18. Fasten a hoist to housing (21) with tooling (B). Put housing (21) in position on the pinion and bearing.
19. Heat bearing cone (25) to a maximum temperature of 135° C (275° F) and install it on-the pinion shaft as shown.

NOTE: Models 950BNSCE and 950BSCE use a nut and keyed washer rather than two nuts and a lock.

20. Install nut (28) on the pinion shaft and put oil on bearings. While the pinion is slowly turned, tighten nut (28) with tool (E) until the torque needed to turn the pinion is 0.9 ± 0.2 N-m (8 ± 2 lb.in. for new bearings).
21. If original bearings are used, tighten nut until torque to turn pinion is 0.5 ± 0.2 N-m (4 ± 2 lb.in.). Put clean oil on lock (27) and install it on the pinion shaft. Install nut (26) with tool (E) on the pinion shaft. Bend the tab of the lock in the groove of nut (26). On models 950BNSCE and 950BSCEpeen nut collar into key into key slot of shaft. Check the torque needed to turn the pinion. The torque still must be 2.0 ± 0.2 N-m (18 ± 2 lb.in.) for new bearings and 0.5 ± 0.2 N-m (4 ± 2 lb.in.) for used bearings. If the torque is not correct, an adjustment must be made to nut (28).

22. Use tool group (C) and install the seal in retainer (29). Make sure the lip of the seal is toward the inside of retainer (29) as shown. Put clean oil on the lip of the seal after installation.

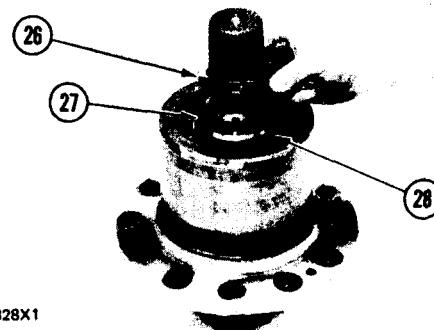
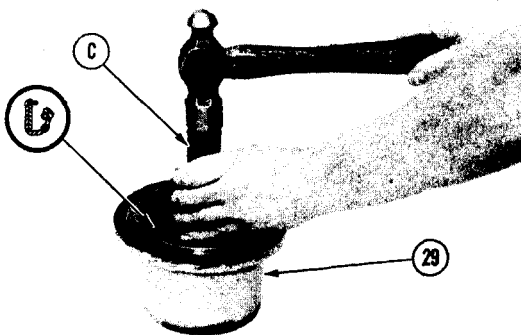
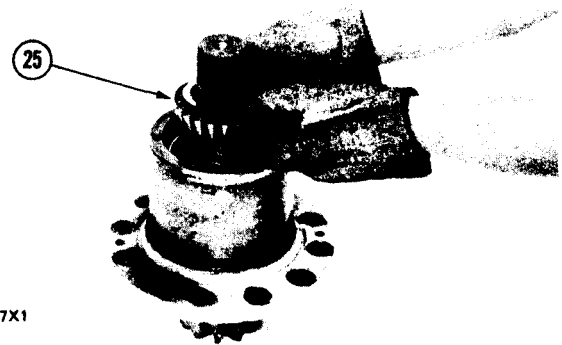
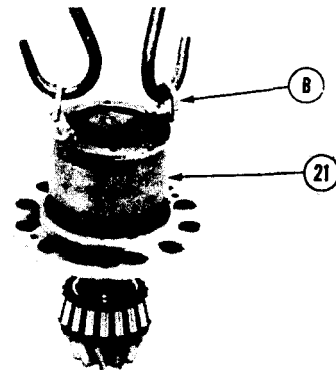
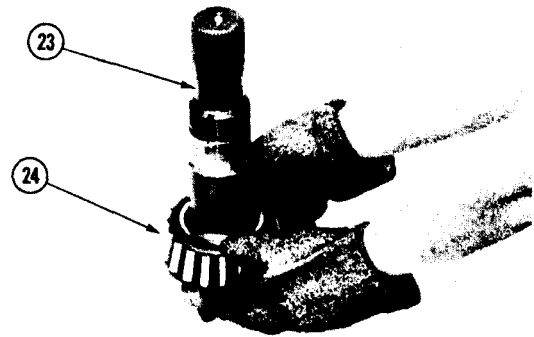

FRONT AND REAR DIFFERENTIALS

23. Install the gasket and retainer (29) on housing (21).
24. Install two 5/8"- 11 NC guide bolts in the carrier assembly. Install shims (30) of the original thickness on the carrier assembly.
25. Fasten a hoist and put the pinion and housing (21) on the carrier assembly. Do not install the O-ring seal around housing (21) at this time. Install three bolts the same distance apart to hold housing (21) in the carrier assembly.
26. Make an adjustment of the differential bearing preload and the gear clearance (backlash) between the bevel gear and pinion as follows:
 - a) Tighten the adjustment nuts until there is a small amount of preload on the bearings.
 - b) Install tool group (D) on the bevel gear as shown to check the gear clearance (backlash) at four locations around the bevel gear 90° apart. Use the lowest indication on tool group(D) as the correct gear clearance (backlash) value. The correct gear clearance (backlash) is 0.20 to 0.43 mm (.008 to .017 in.).
 - c) If the gear clearance (backlash) is too much, loosen upper adjustment nut (18) and tighten lower adjustment nut (15) the same amount to change the gear clearance (backlash). If the gear clearance (backlash) is not enough, loosen lower adjustment nut (15) and tighten upper adjustment nut (18) the same amount to change the gear clearance (backlash).
 - d) Tighten upper adjustment nut (18) until a torque of 4.0 ± 0.6 N-m (35 ± 5 lb.in.) is needed to turn the pinion shaft.
 - e) Check the gear clearance (backlash) again as in Steps b and c.
27. Make a check of the tooth contact setting between the bevel gear and pinion after the gear clearance (backlash) and bearing preload adjustments have been made as follows:
 - a) Put a small amount of Prussian blue, red lead or paint on the bevel gear teeth. Turn the pinion in both directions and check the marks made on the bevel gear teeth.

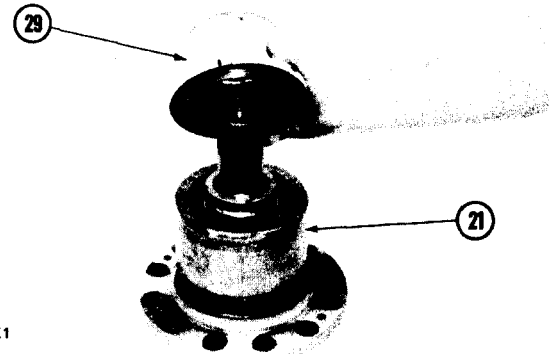

B29330X1

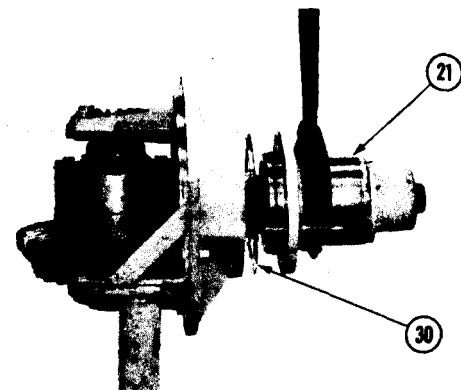

B29331X1

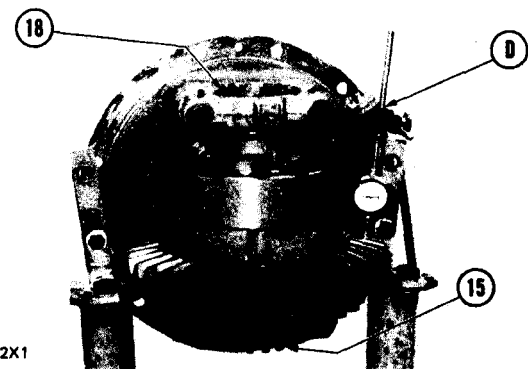

B29332X1

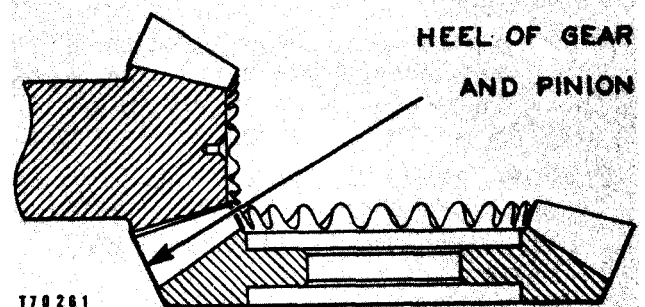

T70201

ALIGNMENT OF BEVEL GEAR AND PINION

FRONT AND REAR DIFFERENTIALS

- b) With no load, correct tooth contact setting will be as shown. The area of contact starts near the toe of the gear and goes 30% to 50% up the length of the tooth. With this setting, when a load is put on the gear, the load will be over the correct area of the teeth.
- c) [f bevel pinion shaft is too far away from bevel gear, short toe contact will be the result as shown. The teeth of pinion will be in contact with toe ends of convex faces (part that makes a curve toward the outside), and top edge of heel end of concave faces (part that makes a curve toward the inside). To correct this, remove shims from between pinion cage and carrier. After this is done, check gear clearance (backlash) and tooth contact again.
- d) If bevel pinion shaft is too near to center of bevel gear, short heel contact will be the result as shown. The teeth of pinion will be in contact with toe ends of concave faces (part that makes a curve toward the inside) and the heel ends of convex faces (part that makes a curve toward the outside). To correct this, add shims between pinion cage and carrier. After this is done, check gear clearance (backlash) and tooth contact again.

NOTE: Several adjustments of both pinion and bevel gear can be needed before correct tooth contact and gear clearance (backlash) is made. Always remember that a change to gear clearance (backlash) will also change the tooth contact. Therefore, be sure gear clearance (backlash) is in correct adjustment before tooth contact is checked.

- e) After correct gear clearance (backlash) and tooth contact is correct, remove extra Prussian blue, red lead or paint from bevel gear and pinion.
- f) Install the O-ring seal between the pinion housing and carrier assembly. Remove the guide bolts and install the remainder of the bolts that hold the pinion housing in place. Tighten the bolts to a torque of 270 ± 25 N-m (200 ± 20 lb. ft.).

28. Install locks (31), the bolts and lockwire for each adjustment nut. Remove the differential and carrier assembly from tooling (A).

end by:

- a) install front or rear differential

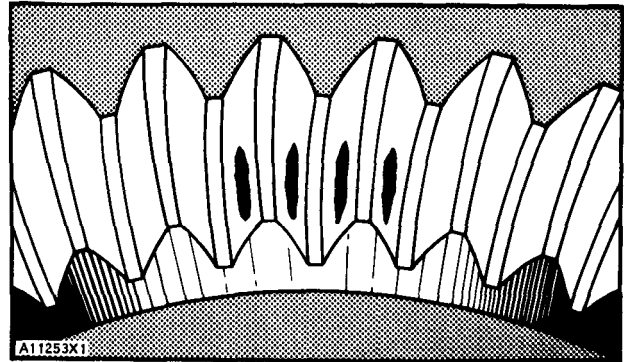

CORRECT TOOTH CONTACT SETTING

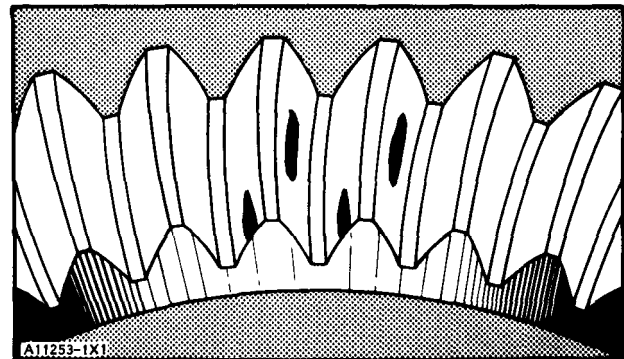

SHORT TOE CONTACT SETTING

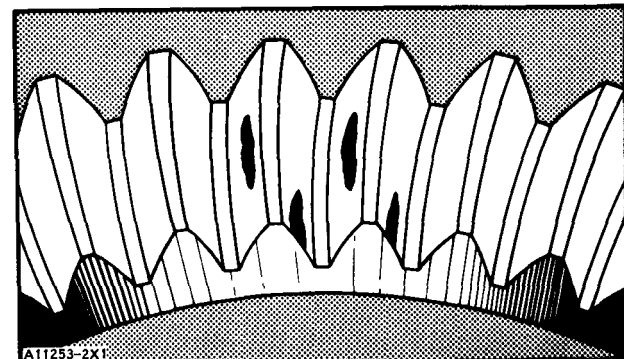

SHORT HEEL CONTACT SETTING

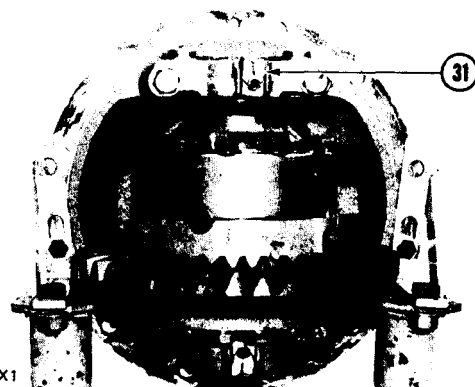

TRANSMISSION OIL FILTER

REMOVE TRANSMISSION OIL FILTER 3179-11

1. Remove the bolts and disconnect oil lines (1) from the oil filter base.

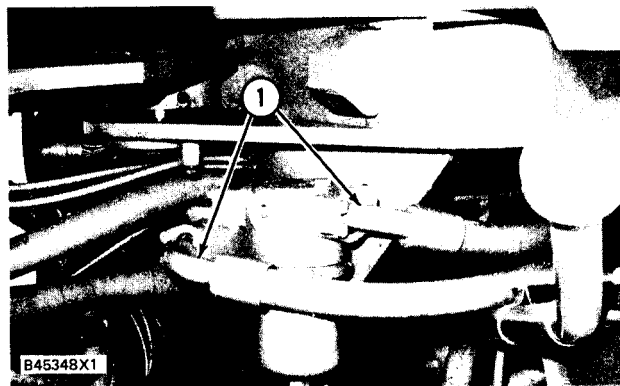

2. Remove the bolts, oil filter base and housing (2) from the machine.

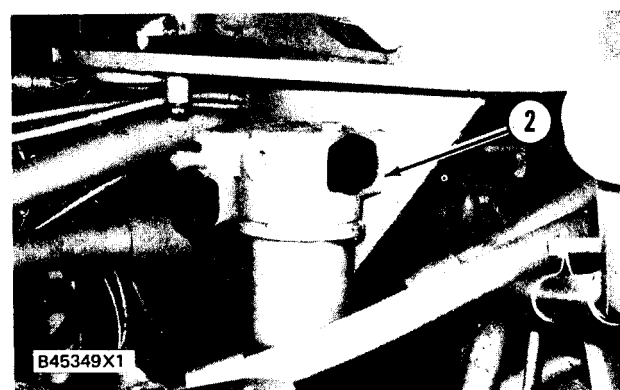

NOTE: If only housing and element are to be removed, see LUBRICATION AND MAINTENANCE GUIDE.

INSTALL TRANSMISSION OIL FILTER 3179-12

1. Put oil filter base and housing (1) into position and install the bolts.

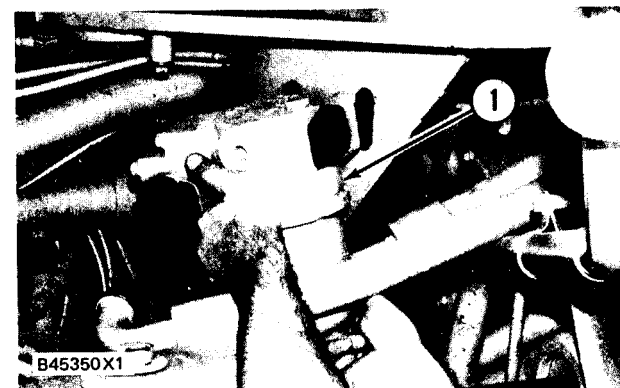

2. Put O-ring seals into position on the oil lines.

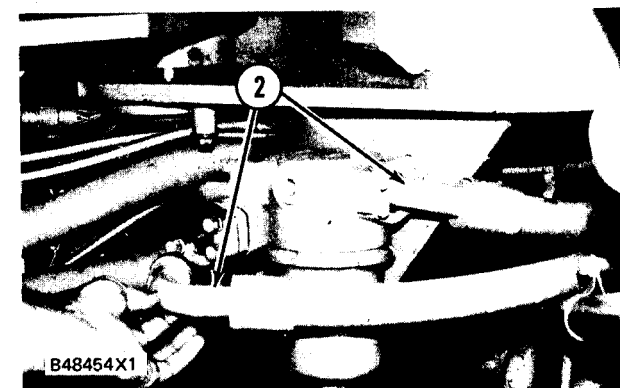

3. Connect oil lines (2) to oil filter base (1).

TRANSMISSION OIL FILTER

DISASSEMBLE TRANSMISSION OIL FILTER 3179-15
NOTE: Do not use an air wrench when the filter housing is removed.

1. Remove housing assembly (2) from base (1).

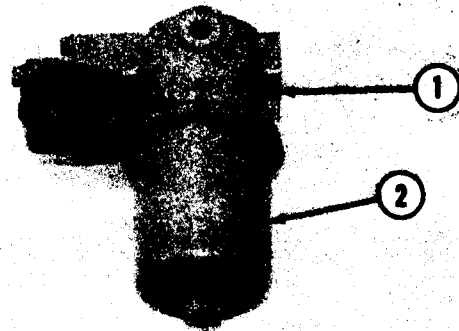

B46320X1

2. Remove the O-ring seal from housing assembly.

3. Remove the filter element from base (2).



B46321X1

4. Remove the bolts and make a separation of adapter (3) from base (2).

5. Remove O-ring seal (4) from adapter (3).

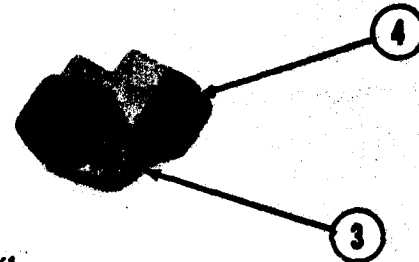

B46322X1

6. If necessary remove plug (5) from hose (2) and check the O-ring seal.

7. Remove plug (9), valve spool (8) and spring (6) from adapter (2).

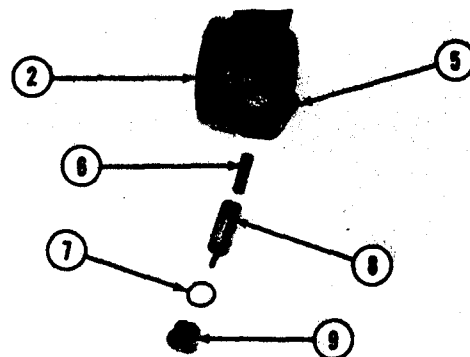

B46323X1

8. Remove O-ring seal (7) from plug (9).

TRANSMISSION OIL FILTER

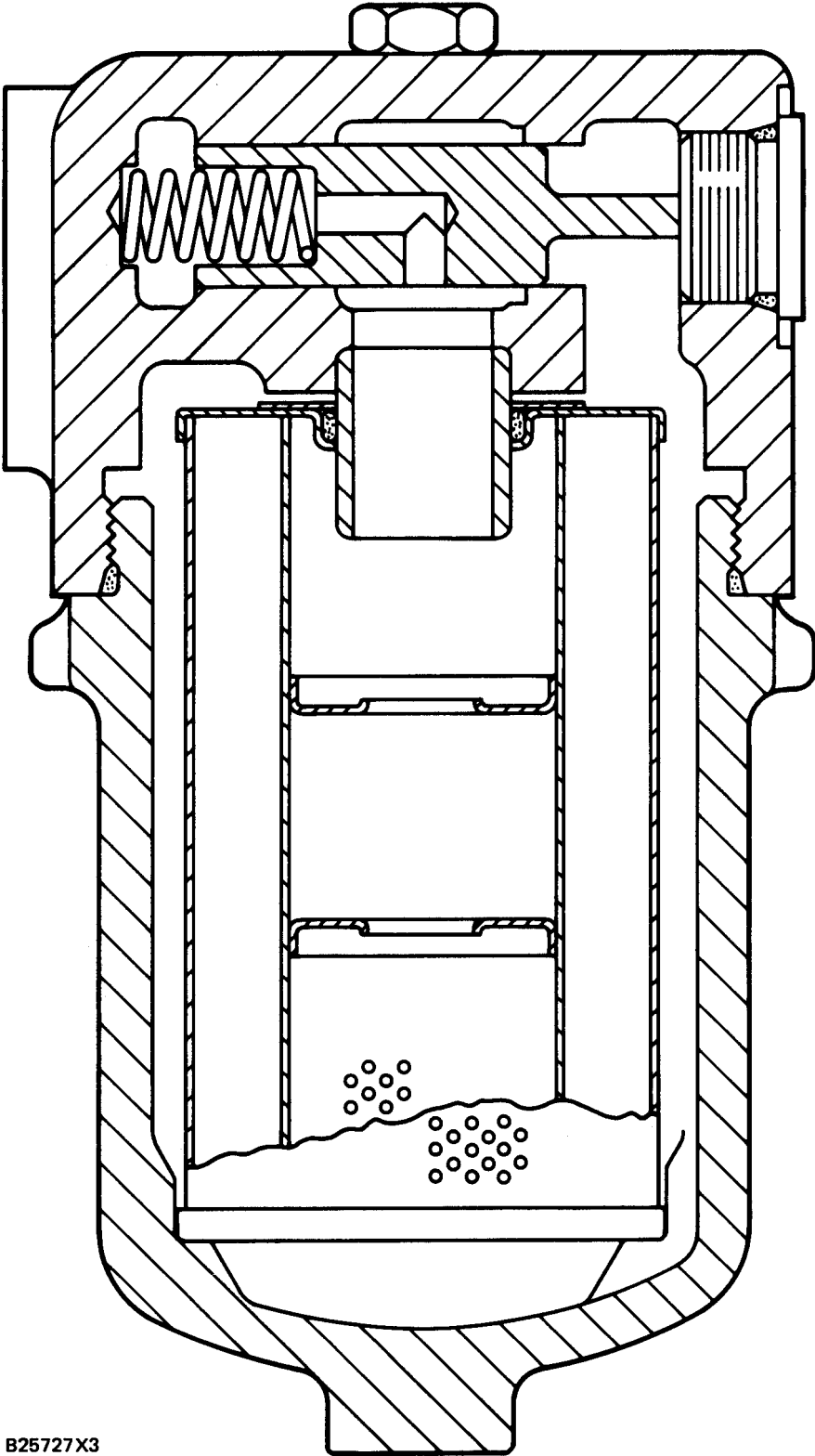

B25727X3

TRANSMISSION OIL FILTER

ASSEMBLE TRANSMISSION OIL FILTER

3179-16

1. Install O-ring seal (2) on plug (3).

2. Install plug (3) in base (1).

3. Install O-ring seal (5) on plug (7).

4. Install spring (4), valve spool (6) and plug (7) in base (1).

5. Put O-ring seal (9) into position on adapter (8).

6. Install adapter (8) on base (1).

7. Install filter element (11) on base assembly (10).

8. Install O-ring seal (12) on housing (13) and put clean oil on it.

9. Install housing (13) on base assembly (10) until the housing makes contact with the base (metal to metal).

NOTE: Do not use an air wrench to tighten the housing.

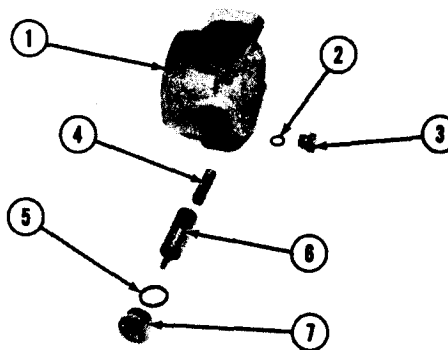

B45324X1



B45325X1

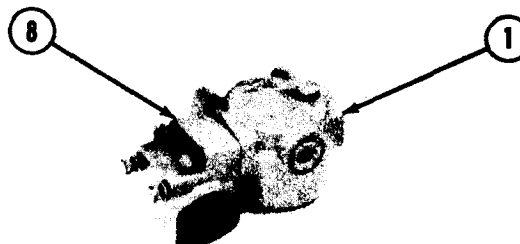

B45326X1

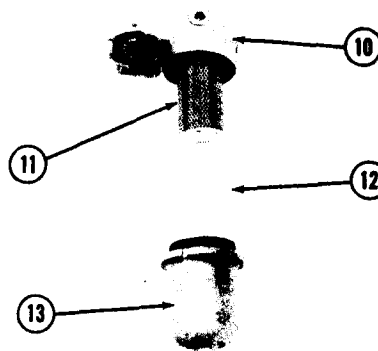

B45327X1

TRANSMISSION OIL PUMP

REMOVE TRANSMISSION OIL PUMP 3153-11

start by:

- a) remove pilot and hydraulic pump*

*This operation is in the VEHICLE SYSTEMS DISASSEMBLY AND ASSEMBLY section.

1. Remove bolts (1) and disconnect tube assembly (2) from the pump.
2. Remove the bolts and disconnect tube assembly (4) from the pump.
3. Remove bolts (3) and remove transmission oil pump (5) from the torque converter housing.

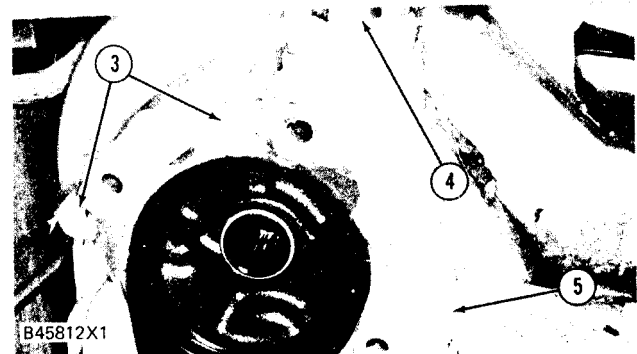
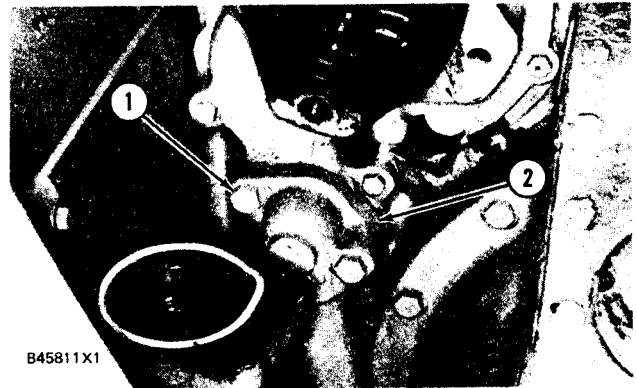

INSTALL TRANSMISSION OIL PUMP 3153-12

1. Make sure the O-ring seals are installed in the pump body and put clean power train oil on them. Fill the pump with clean power train oil also.
 2. Put transmission oil pump (3) in position and install bolts (1) that hold it.
 3. Make sure the O-ring seal is installed in the end of tube assembly (2) and put clean power train oil on it. Connect tube assembly (2) to the pump.
 4. Make sure the O-ring seal is installed in the end of tube assembly (4) and put clean power train oil on it. Connect tube assembly (4) to the pump.
- end by:

- a) install pilot and hydraulic pump*

*This operation is in the VEHICLE SYSTEMS DISASSEMBLY AND ASSEMBLY section.

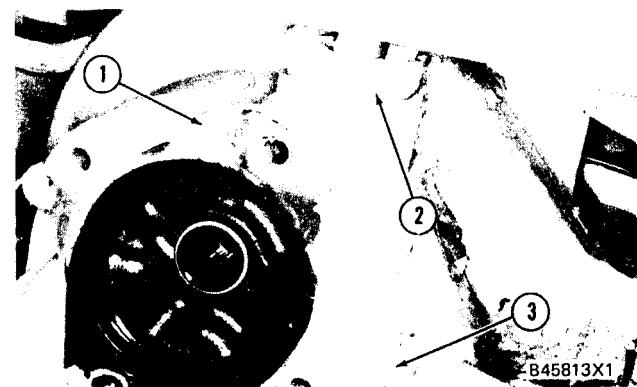

TRANSMISSION OIL PUMP

DISASSEMBLE TRANSMISSION OIL PUMP

3153-15

start by:

- a) remove transmission oil pump

NOTE: Put marks on all parts for correct installation.

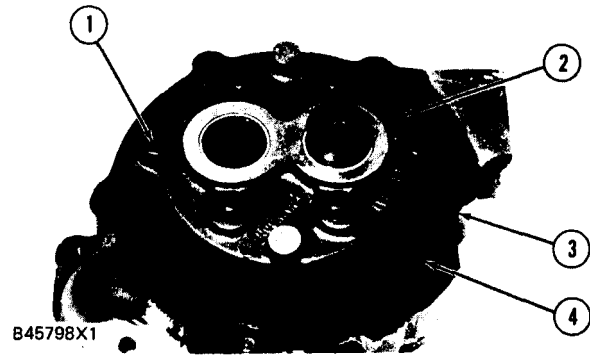

1. Remove O-ring seal (4) from manifold (3).

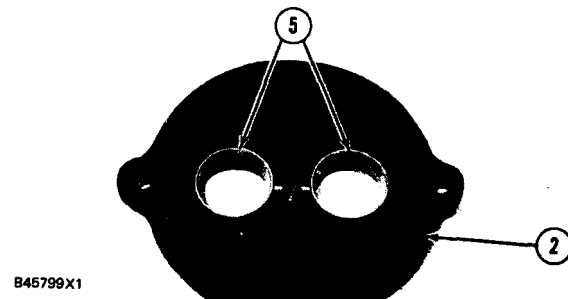

2. Remove bolts (1) and make a separation of cover (2) from manifold (3).

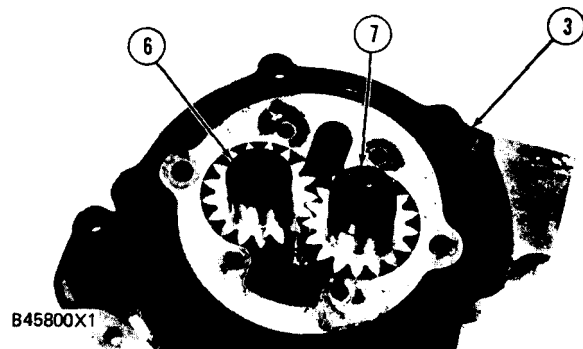

3. If necessary remove bearing (5) from cover (2)

4. Remove gears (6) and (7) from manifold (3).



5. Remove body (8) from manifold (3).

TRANSMISSION OIL PUMP

6. Remove four dowels (9) if necessary from body (8).

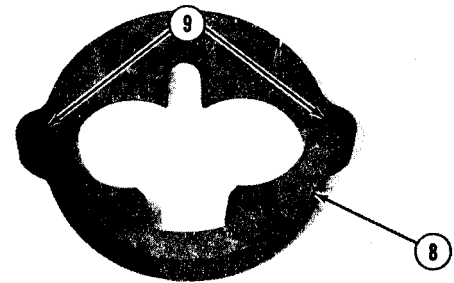

B45802X1

7. If necessary, remove bearings (10) from manifold (3).

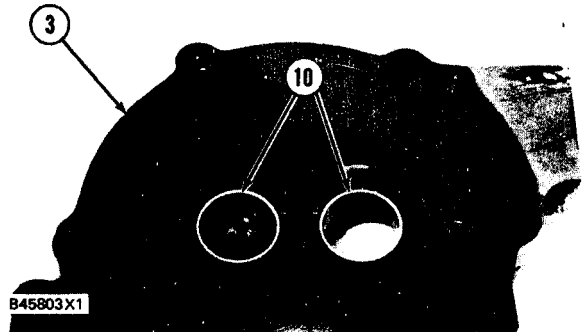

B45803X1

ASSEMBLE TRANSMISSION OIL PUMP

3153-16

Tools Needed		A
1P510	Driver Group	1

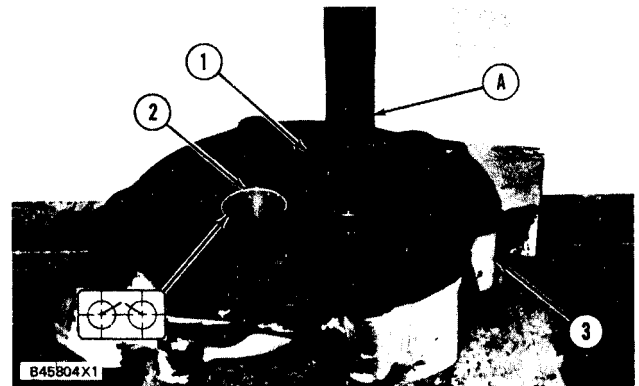

B45804X1

1. Use tool group (A) and a press to install bearings (2) in manifold (3) until they are 1.5 ± 0.5 mm ($.059 \pm .020$ in.) below the surface of manifold (3). Make sure the bearing joints are $30^\circ \pm 15^\circ$ from the centerline toward oil passage (1) as shown.

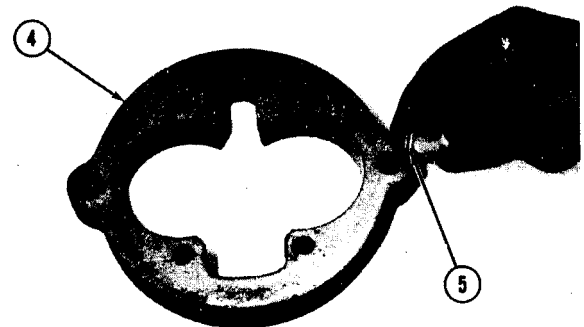

B45805X1

Install the four dowels (5) in body (4) until they extend 5.0 ± 0.5 mm ($.197 \pm .020$ in.) above the surfaces of the body.

TRANSMISSION OIL PUMP

3. Install body (4) on manifold (3) as shown.

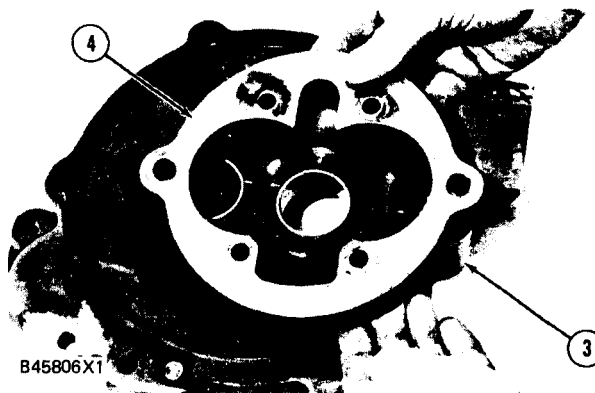

4. Put clean oil on the bearings and install gears (6) and (7) in manifold (3) as shown.



5. Use tool group (A) and a press to install bearings (9) in cover (10) until they are 1.5 mm (.059 in.) below the surface of cover (10). Make sure the bearing joints are $30^\circ \pm 15^\circ$ from the centerline toward oil passage (8) as shown.

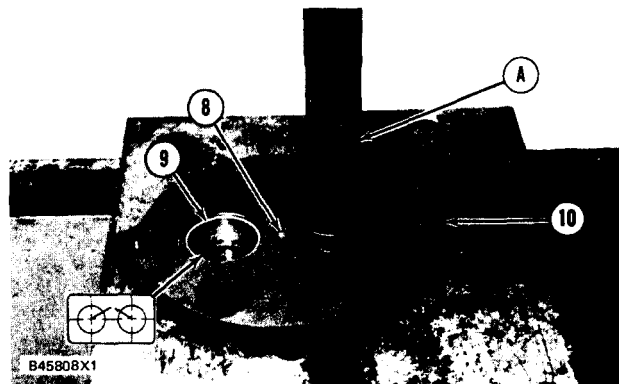

6. Put clean oil on the bearings and install cover (10) over the gears on body (4).

7. Install bolts (11) to hold the pump together.

NOTE: The pump gears must turn freely by hand after bolts (11) are tightened.

8. Install O-ring seal (12) on the manifold end by:
a) install transmission oil pump

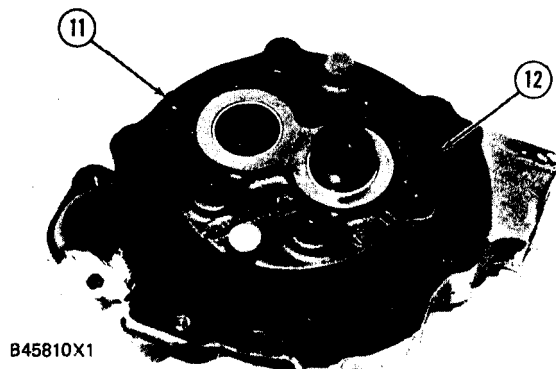

TORQUE CONVERTER OUTLET RELIEF VALVE

REMOVE TORQUE CONVERTER OUTLET RELIEF VALVE 3100-11

NOTE: The torque converter outlet relief valve is located on the left side of the torque converter when facing the front of the machine.

1. Drain the transmission oil.
2. Remove the bolts and disconnect tube assembly (1) from the outlet relief valve.
3. Remove the bolt and disconnect the clip that holds wire assembly (2) to outlet relief valve (3).
4. Remove the three bolts and remove outlet relief (3) from the torque converter.

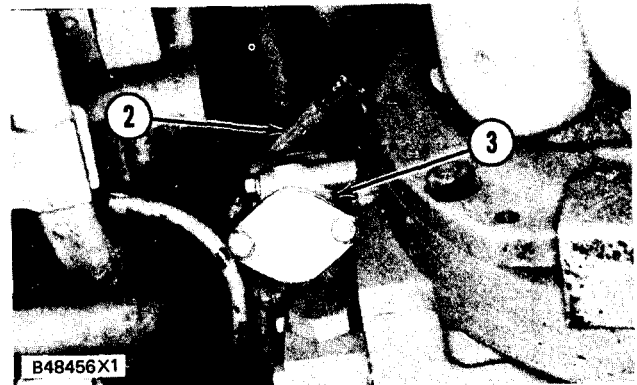
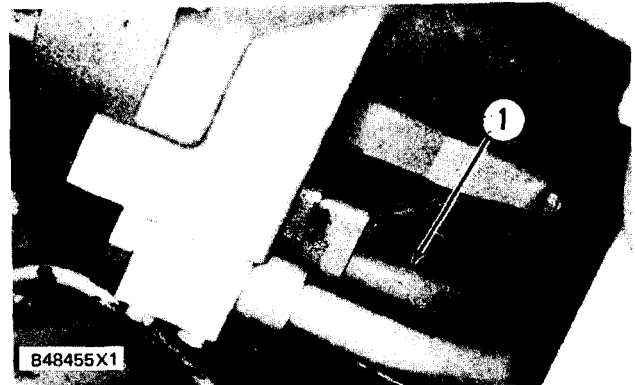

INSTALL TORQUE CONVERTER OUTLET RELIEF VALVE 3100-12

1. Install the O-ring seal on outlet relief valve (2).
2. Install outlet relief valve (2) on the torque converter.
3. Install the bolt and connect the clip that holds wire assembly (1) to the outlet relief valve.
4. Remove the three bolts and remove outlet relief (3) from the torque converter.

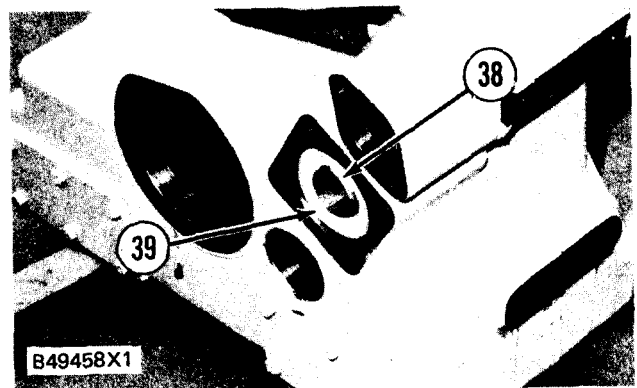
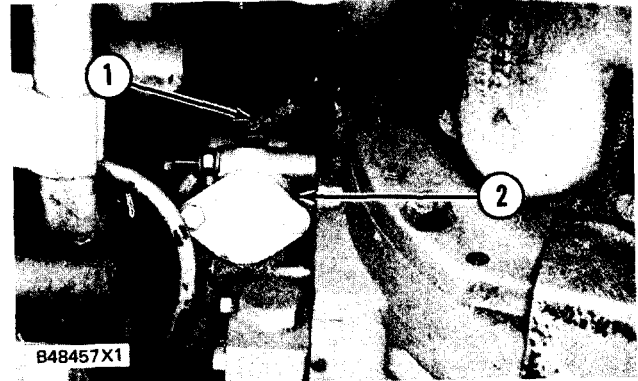

TORQUE CONVERTER OUTLET RELIEF VALVE

DISASSEMBLE TORQUE CONVERTER OUTLET RELIEF VALVE 3100-15

start by:

- a) remove torque converter outlet relief valve

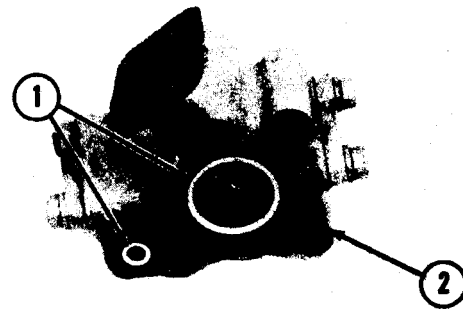

B31604X2

- 1. Remove O-ring seals (1) from relief valve (2).

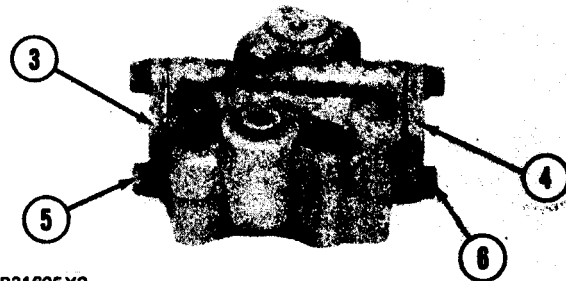

B31605X2

- 2. Remove bolts (5) and (6). Remove covers (3) and (4) and the O-ring seals from the relief valve.

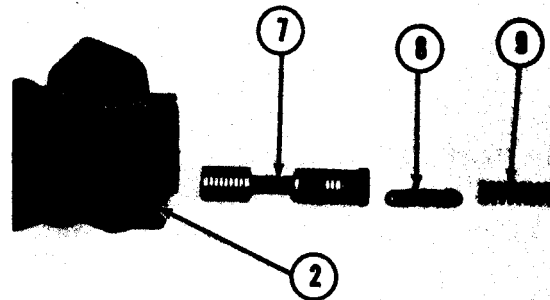

B31606X2

- 3. Remove spring (9), spacers (8) and valve spool (7) from relief valve (2).

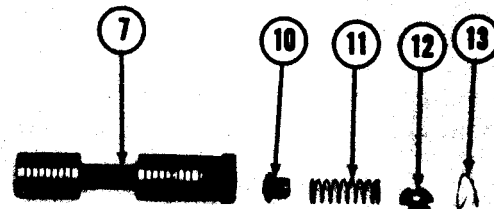

B31607X1

- 4. Remove ring (13), retainer (12), spring (11) and poppet (10) from valve spool (7).

TORQUE CONVERTER OUTLET RELIEF VALVE

ASSEMBLE TORQUE CONVERTER OUTLET RELIEF VALVE 3100-16

1. Make sure all of the parts of the relief valve are clean and free of dirt and foreign material. Put clean oil on all the parts at assembly.

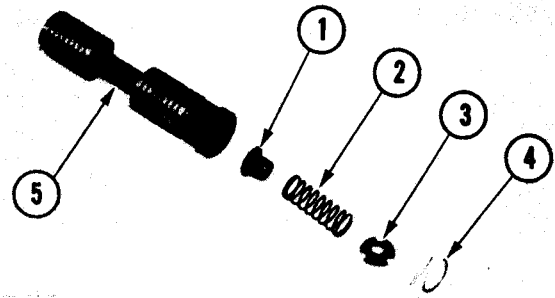

B31608X1

2. Install poppet (1), spring (2), retainer (3) and ring (4) in valve spool (5). Make sure the shoulder on retainer (3) is toward spring (2) when it is installed.

3. Install valve spool (5), spacers (6) and spring (7) in valve body (8) as shown.

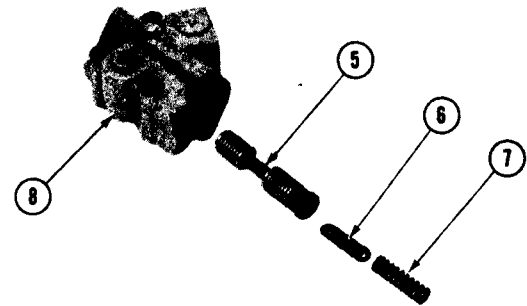

B31609X1

NOTE: Spacers (6) are used to make an adjustment to the pressure needed to open the torque converter outlet relief valve. See POWER SHIFT TRANSMISSION TESTING AND ADJUSTING for the correct pressure setting.

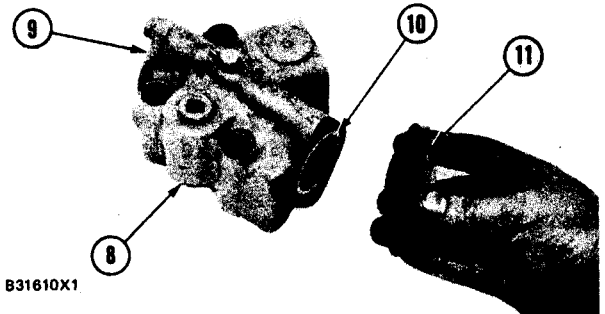

B31610X1

4. Install O-ring seals (10) and covers (9) and (11) on the ends of valve body (8).

5. Install O-ring seals (12) and (13) in valve body (8).

end by:

- a) install torque converter outlet relief valve

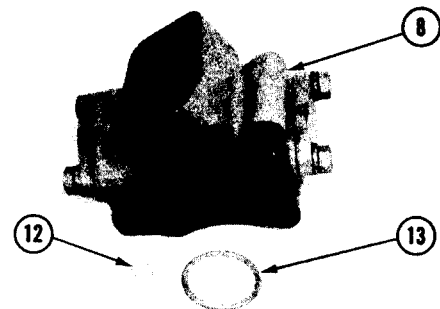

B31611X1

ENGINE AND TRANSMISSION

REMOVE ENGINE AND TRANSMISSION

1000 & 3000-11

Tools Needed	A	B	C
2V2156 Link Bracket	2		
OTC 1790 Transmission Jack		1	
8S9906 Ratchet Puller			1

start by:

- a) remove hood*
- b) remove muffler*

WARNING

If NBC exposure is suspected, all air filter media should be handled by personnel wearing protective equipment. Consult your unit NBC Officer or NBC NCO for appropriate handling or disposal instructions.

- c) remove air cleaner housing*
- d) remove radiator and guard*
- e) remove rear drive shaft
- f) remove center drive shaft

*This operation is in the ENGINE DISASSEMBLY AND ASSEMBLY section.

NOTE: It is not necessary to remove the transmission when just the engine is to be removed. See ENGINE DISASSEMBLY AND ASSEMBLY.

1. Remove nuts (2) and disconnect the disconnect switch (1) from the frame.

WARNING

To prevent personal injury, release the pressure in the air reservoir before any lines are disconnected.

NOTE: Models 950BNS and 950BS shown. Hose locations for models 950BNSCE and 950BSCE are slightly different.

2. Disconnect air lines (3) from the engine.

3. Put identification on wires (4), (5) and (6). Disconnect wires (4), (5) and (6) from the starter and the solenoid.

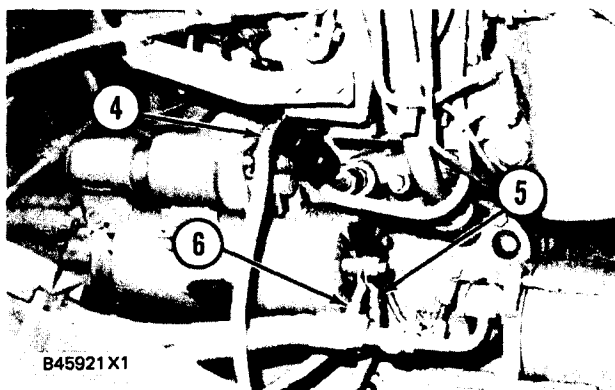
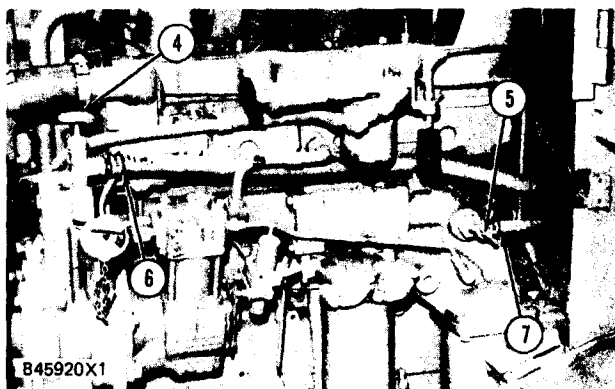
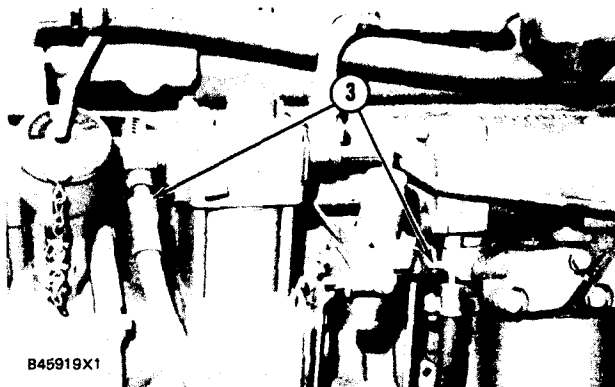
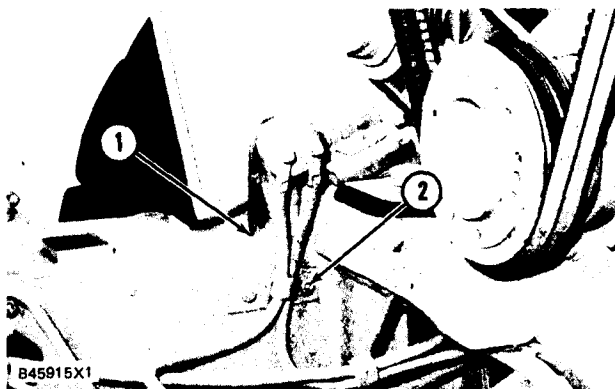

ENGINE AND TRANSMISSION

4. For Models 950BNS and 950BS, disconnect control cable (7) from governor. Remove screws and bracket (8) from engine.

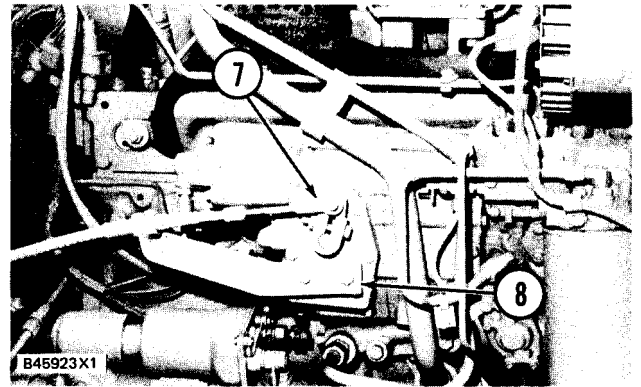

Illustration of 950BNS and 950BS

5. For Models 950BNSCE and 950BSCE:
 - a) Remove screws, cover (49), and gasket.
 - b) Disconnect control cable (50) from governor lever (51).
 - c) Remove lever, screws, and housing (52) from the engine.

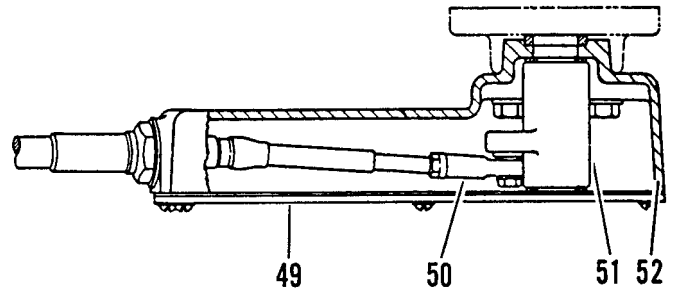
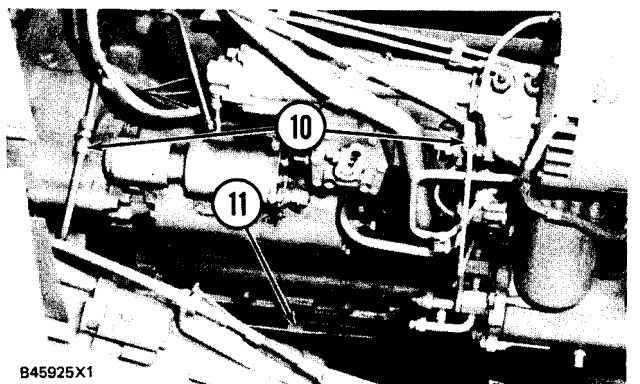
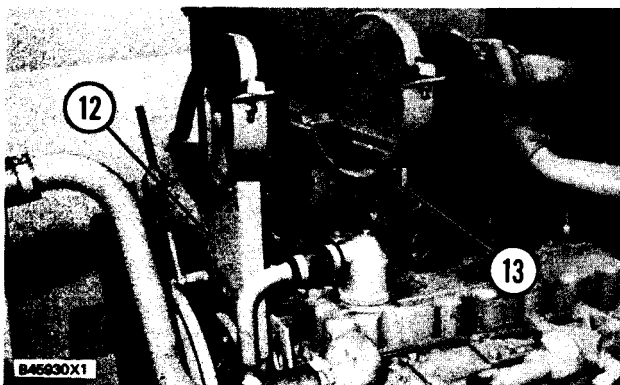
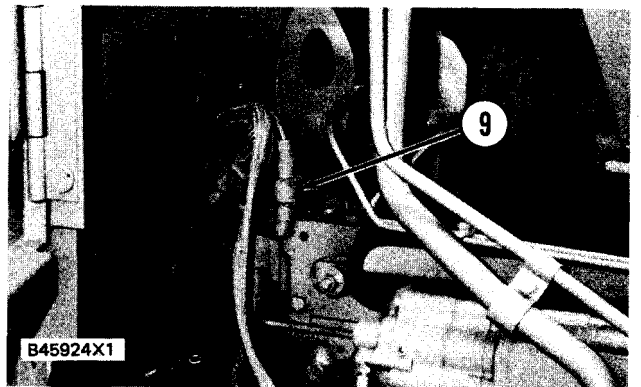

Illustration of 950BNSCE and 950BSCE

6. Put identification on wire harness (9) and disconnect them at the rear of the machine.
7. Disconnect fuel lines (10) from the fuel injection pump housing and the rear of the engine.
8. Disconnect clips (11) that hold the fuel line to the oil pan.
9. Remove the nuts and bolts and remove muffler brackets (12) and (13) from the engine.



ENGINE AND TRANSMISSION

10. Remove the bolt and disconnect clip (14) that holds the breather tube to the engine.

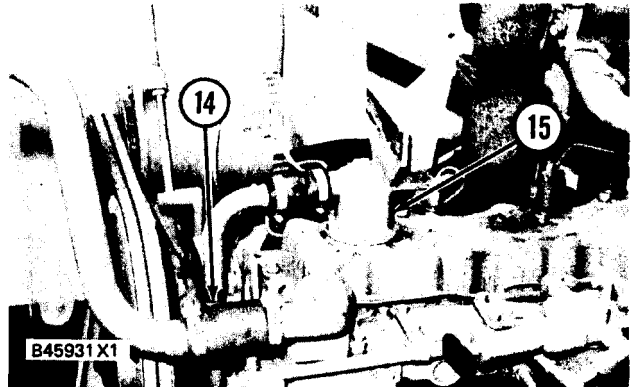

11. Remove the bolt and remove breather assembly (15) from the valve cover.

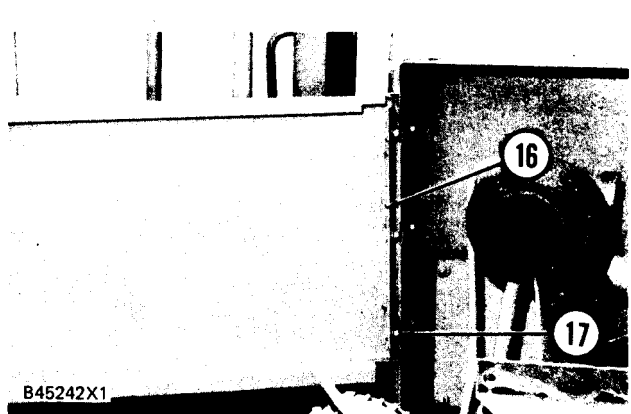

12. Remove nuts (17) and upper access door (16) from both sides of the machine.

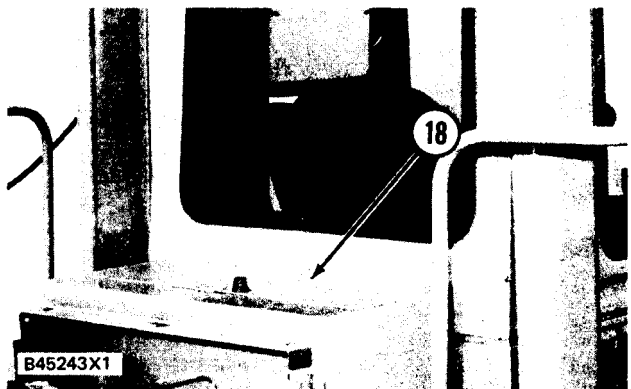

13. Open access door (18) behind the cab.

14. Disconnect wire harnesses (19) from behind the cab.

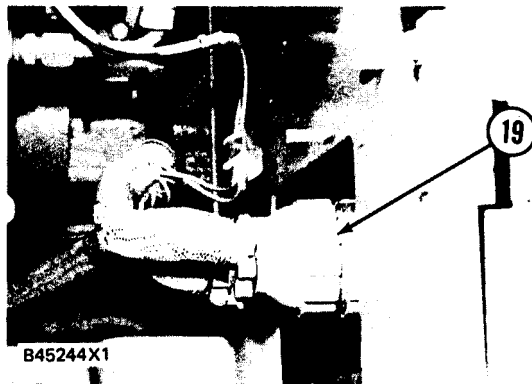

ENGINE AND TRANSMISSION

15. Disconnect two air lines (20) from each air/hydraulic cylinder.

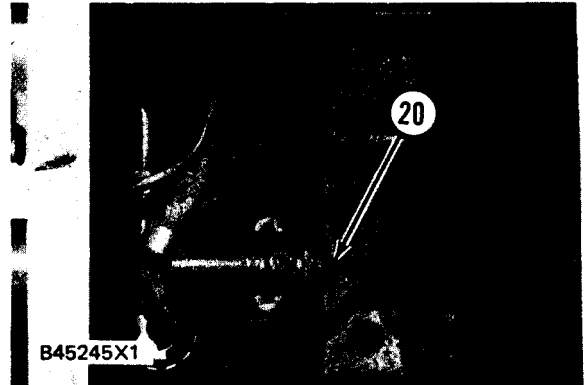

16. Fasten tooling (A) and a hoist to firewall (21) as shown.

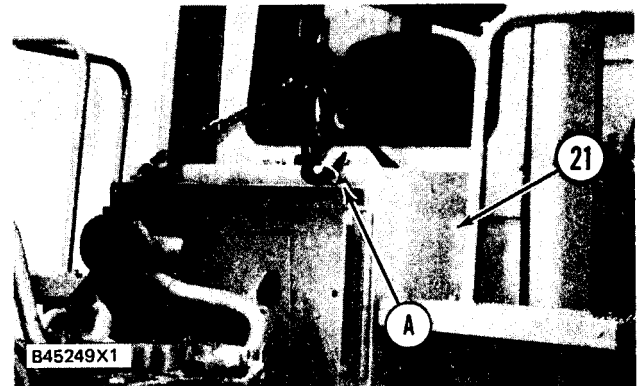

17. Disconnect three clips (22) that hold the hose and wire harnesses to the frame.

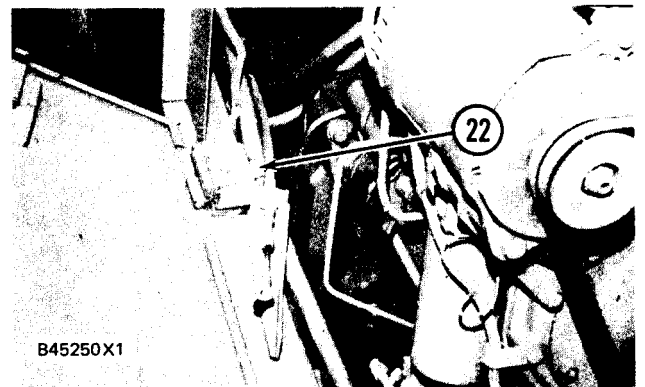

18. Remove the bolts and cover (23) from the electrical box.



ENGINE AND TRANSMISSION

19. Remove nuts (25) and disconnect electrical box (24) from the firewall.

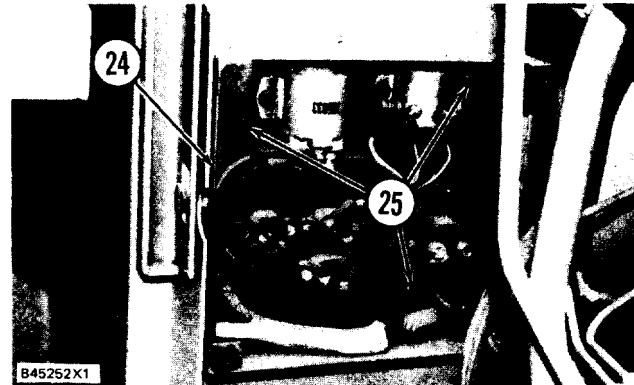

20. Disconnect wire harness (26) (right side only).

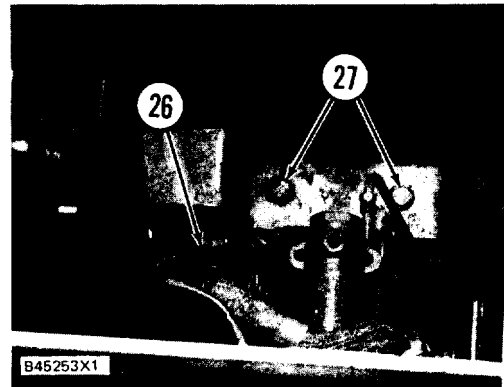

21. Remove two bolts (27) from each side of the firewall.

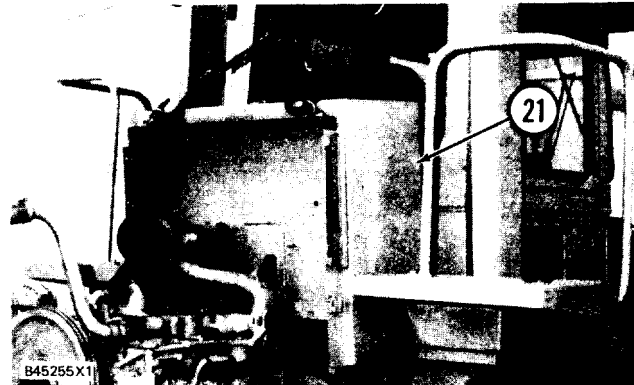

22. Make sure all hoses, wires and clips are disconnected and remove firewall (21) from the machine. The weight of the firewall is 109 kg (240 lb)

23. Remove the bolts and disconnect hose assembly (28) from the transmission pump.

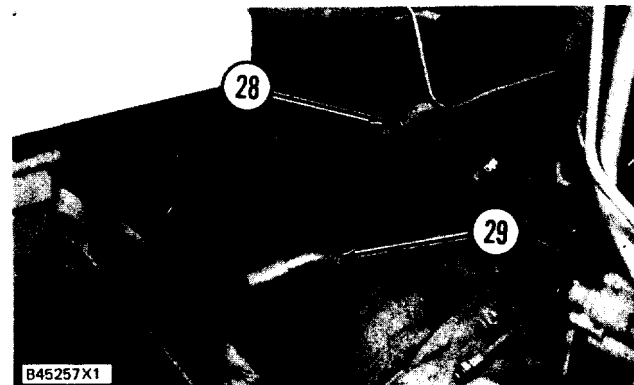

24. Remove the bolts and disconnect hose assembly (29) from the transmission.

ENGINE AND TRANSMISSION

25. Remove air lines (20) and (30) from the machine.

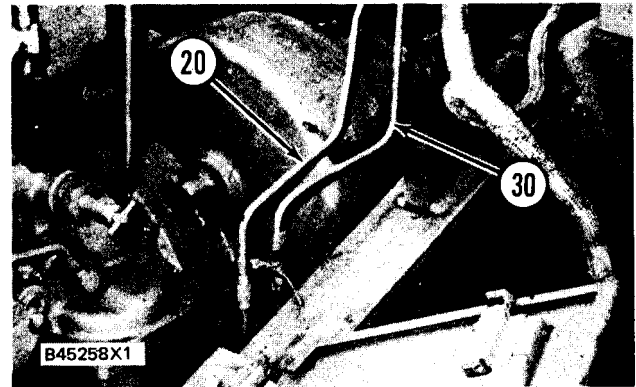

26. Remove the bolts and disconnect hose assemblies (31) and (32) from the pilot and hydraulic pump.

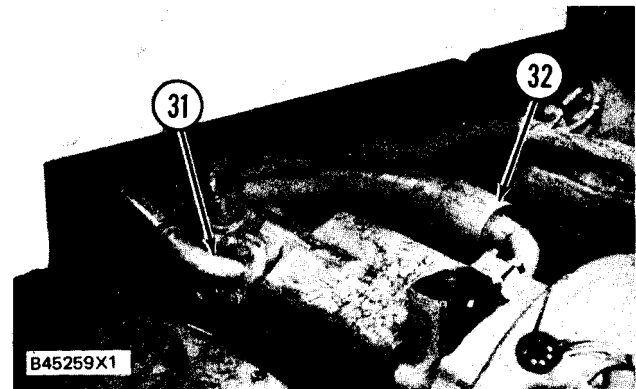

27. Remove the screws and cover (33) from the transmission neutralizer and disconnect cable (35). See REMOVE TRANSMISSION NEUTRALIZER .(Page 5-425)

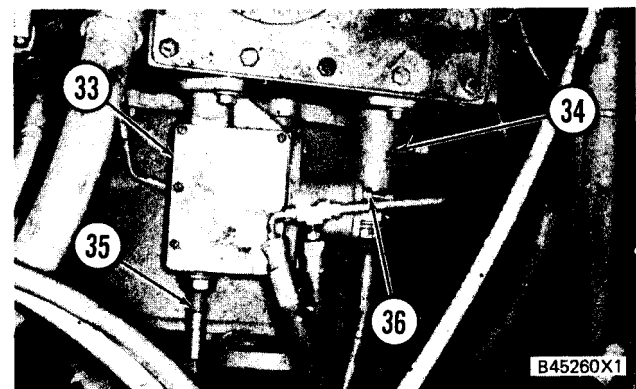

28. Disconnect tube (36) from the transmission neutralizer.

29. Remove the bolts and disconnect transmission selector (34) from the transmission hydraulic control by removal of the notch from the slot.

30. Disconnect wire harness (37).

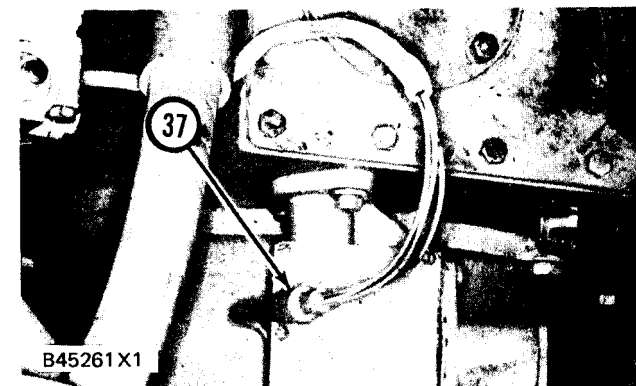

ENGINE AND TRANSMISSION

31. Remove bolts (38) and loosen the clamp on tube assembly (39). Remove tube assembly (39) from the bottom of the hydraulic pump.

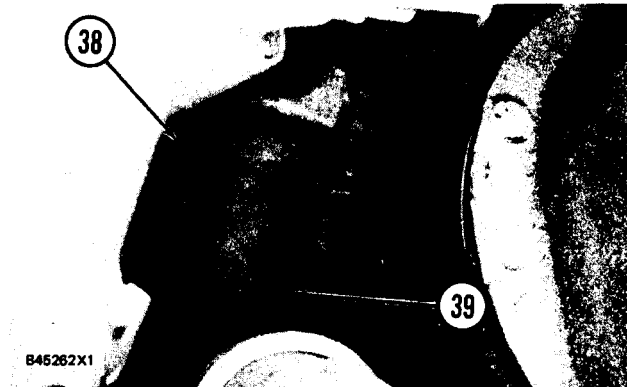

32. Disconnect air line (42) from the transmission.

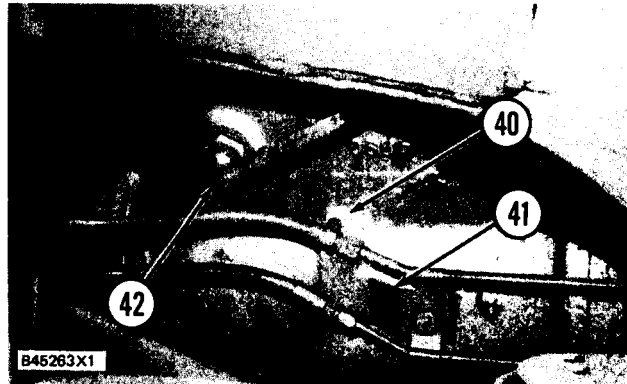

33. Remove bolt (40) and disconnect fuel line bracket (41) from the side of the transmission.

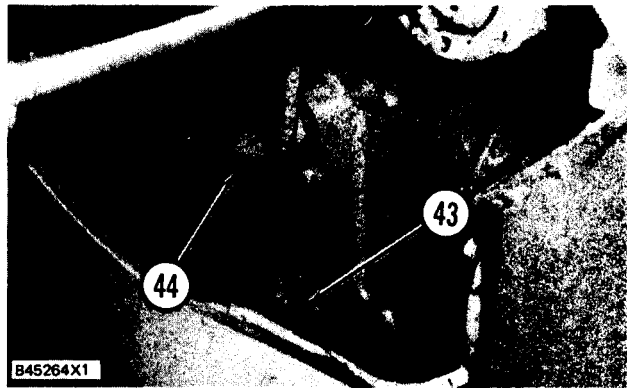

34. Remove the bolts and disconnect oil filler tube (44) and dipstick tube (43) from the transfer case.

35. Install a 3/4"- 10 NC eyebolt (45) to the transmission, tool (C) to the lifting bracket and a hoist to the engine and transmission as shown.

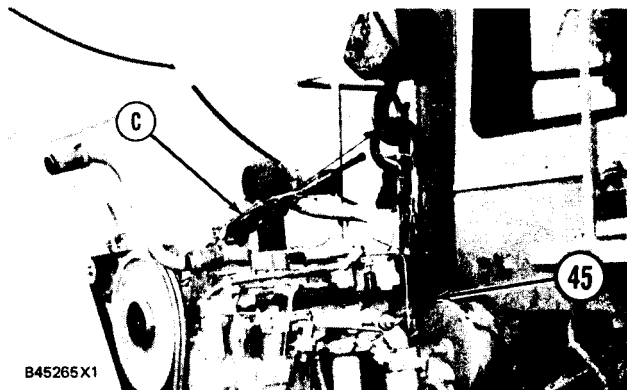

ENGINE AND TRANSMISSION

36. Put tool (B) in position under the transmission as shown when the support brackets are removed.

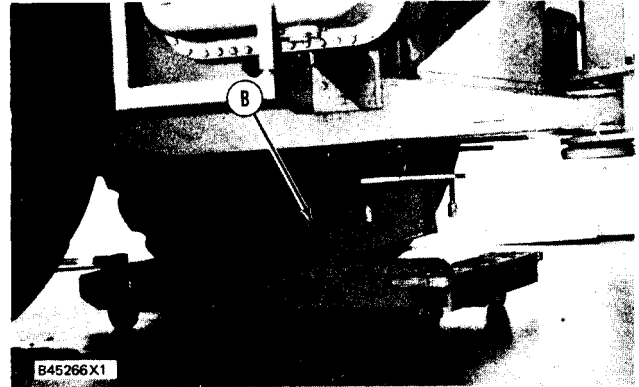

37. Remove the bolts and remove caps (46) from each side of the transmission.



38. Remove the bolts and remove support brackets (47) from each side of the transmission.

39. Remove bolts (48), the nuts and the washers from the front engine mounts.

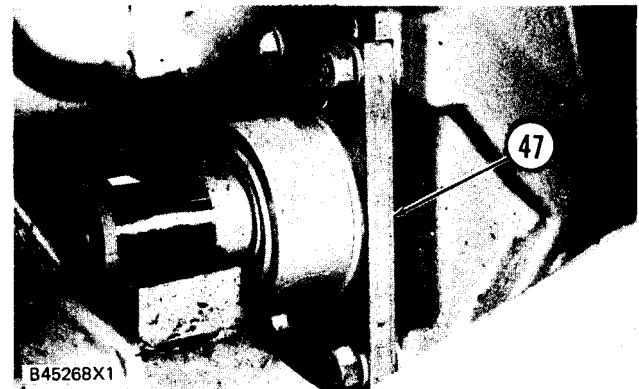

40. Lift up slightly on the engine and transmission and remove them as a unit. The weight of the engine and transmission is 1693 kg (3750 lb).

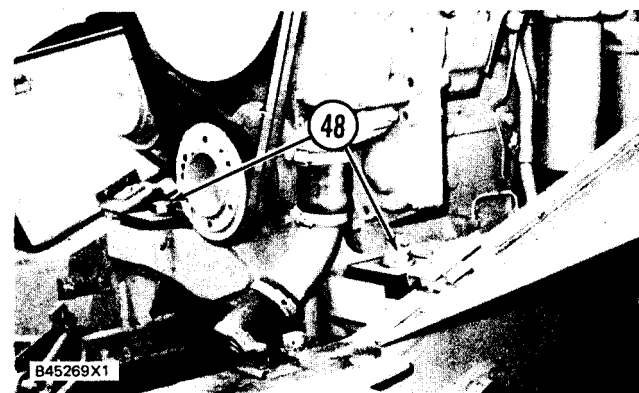

ENGINE AND TRANSMISSION

INSTALL ENGINE AND TRANSMISSION

1000 & 3000-12

Tools Needed		A	B	C
8S9906	Ratchet Puller	1		
	OTC 1790 Transmission Jack		1	
2V2156	Link Bracket			2

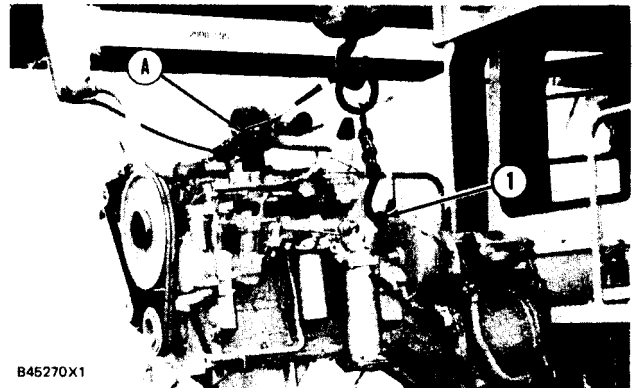

1. Install a 3/4"- 10 NC eyebolt (1) on the transmission and fasten tool (A) to the front of the engine with a hoist as shown.

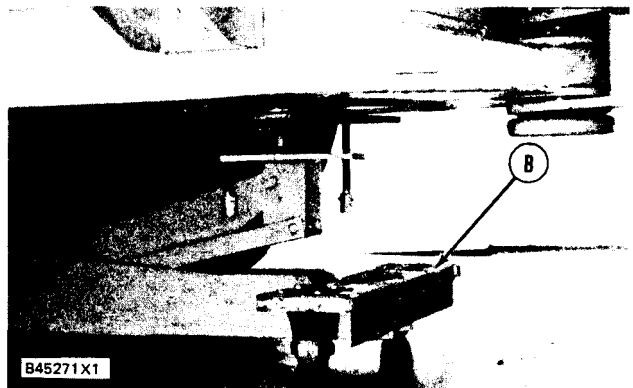

2. Put the engine and transmission in position on the machine.

3. Put tool (B) in position under the transmission when the transmission support bracket is installed.

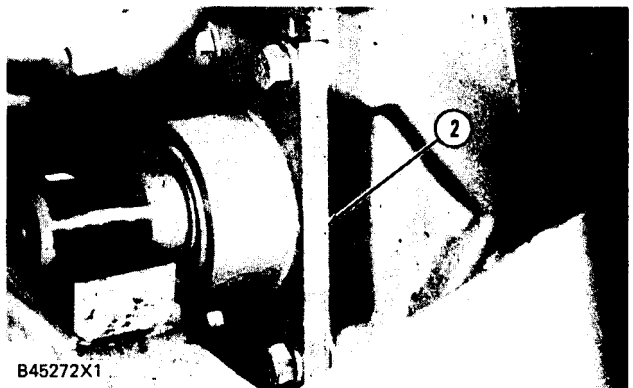

4. Install support brackets (2) to both sides of the transmission.

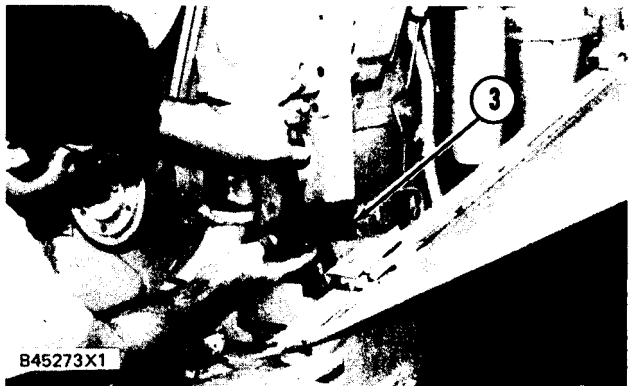

5. Install engine support assemblies (3) to both sides of the engine.

ENGINE AND TRANSMISSION

6. Install caps (4) that hold the transmission support brackets to both sides of the transmission.

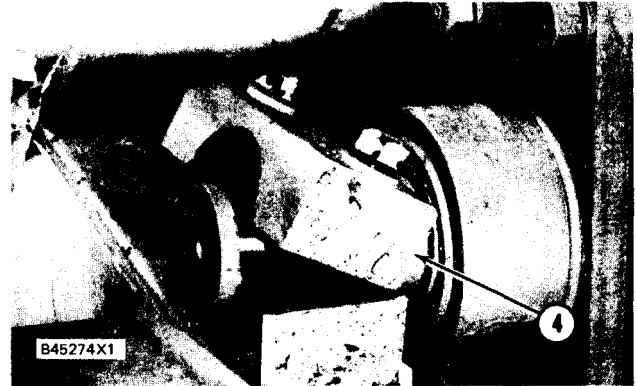

7. Make sure the seal is in place on filler (5) and the gasket is in place on dipstick tube (6) and connect them to the transfer gear case.

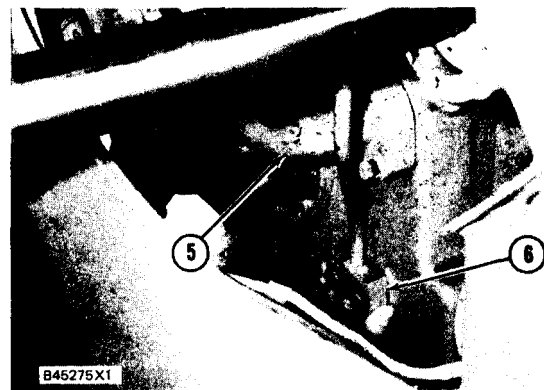

8. Connect air line (7) and fuel line bracket (8) to the side of the transmission housing.

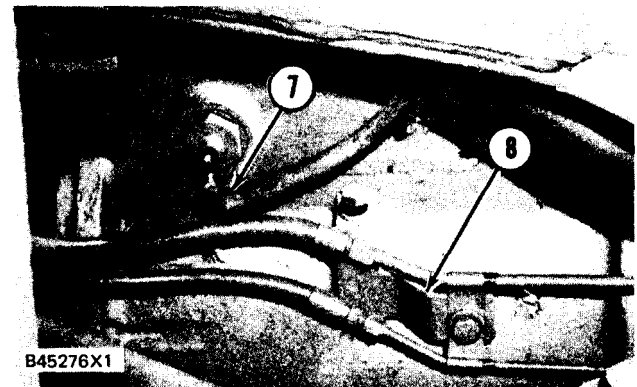

9. Install tube assembly (9) on the hose and tighten the clamp.

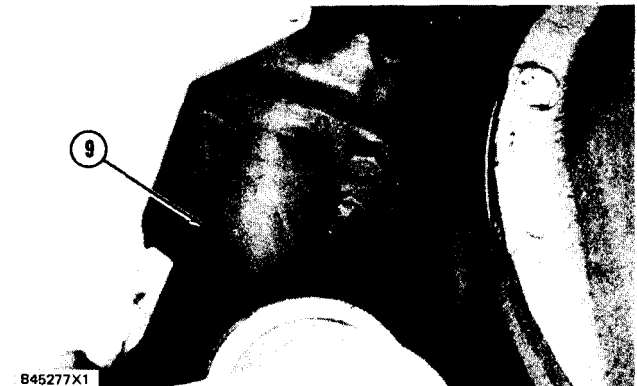

10. Make sure O-ring seal is in place and connect tube assembly (9) to the bottom of the hydraulic pump.

ENGINE AND TRANSMISSION

11. Connect wire harness (10).

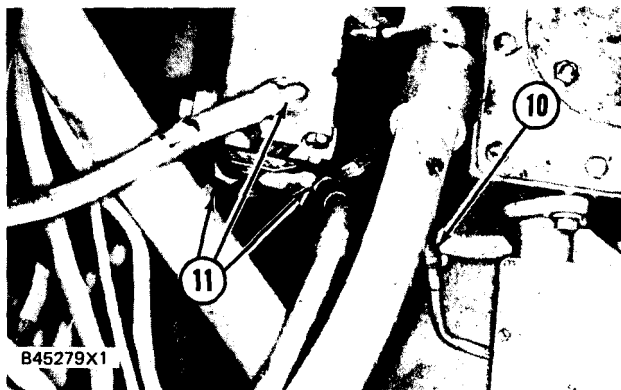

12. Connect hose assemblies (11) to the hydraulic pilot pump.

13. Connect cable assembly (14) to the cam in the transmission neutralizer. See **INSTALL TRANSMISSION NEUTRALIZER** in **VEHICLE SYSTEMS DISASSEMBLY AND ASSEMBLY**.

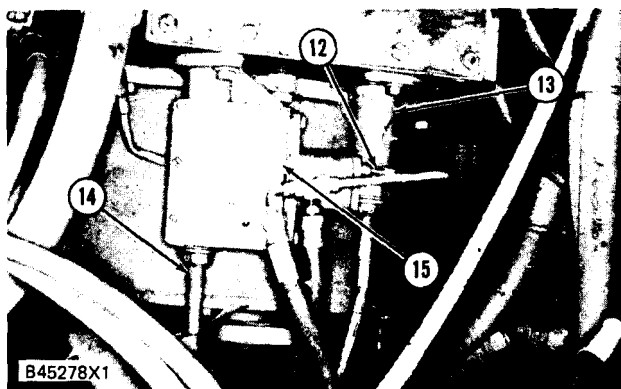

14. Put the gasket and cover (15) in place.

15. Make an adjustment to the transmission neutralizer control group. See **POWER SHIFT TRANSMISSION. TESTING AND ADJUSTING**.

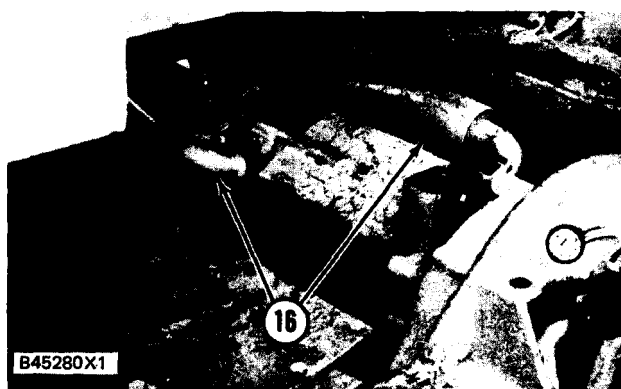

16. Install the notch on the opening (slot) in the transmission hydraulic control valve. Connect transmission selector control (13) to the transmission hydraulic control valve.

17. Connect tube assembly (12) to the transmission neutralizer.



18. Connect hose assemblies (16) to the hydraulic pump.

19. Install brake lines (17) on the machine.

ENGINE AND TRANSMISSION

20. Connect hose (18) to the transmission oil pump.

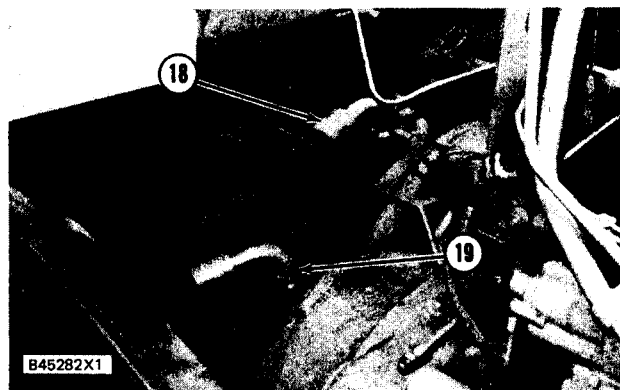

21. Connect hose (19) to the transmission.



22. Fasten tooling (C) and a hoist to firewall (20) and install it on the machine.

23. Install two bolts (21) to both sides of the firewall to hold it in place.

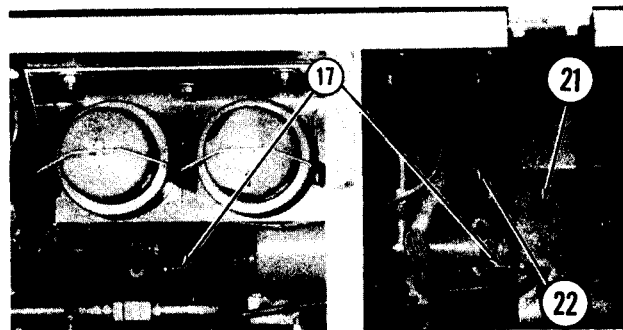

24. Connect brake lines (17) to the air/hydraulic cylinders.

25. Connect wire harness (22).

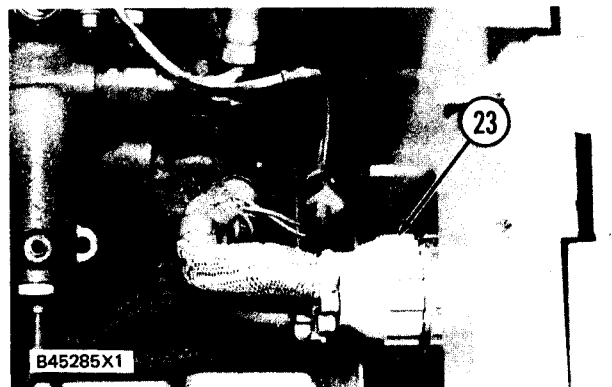

26. Connect wire harness (23) to the back of the cab.

ENGINE AND TRANSMISSION

27. Connect electrical box (24) to the back of the fire wall with the nuts that hold it.



28. Install cover (25) to the electrical box.



29. Connect wire harness (27) to the side of the frame with clips (26).

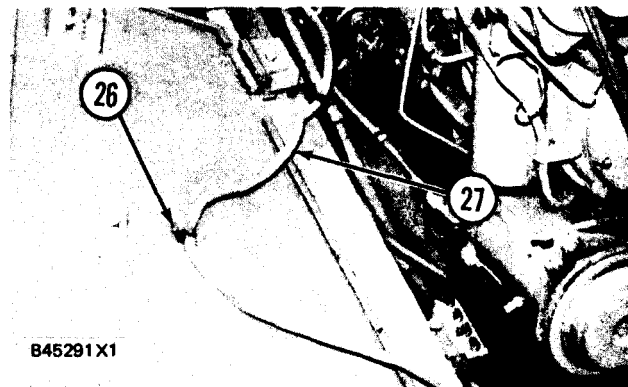

30. Close access door (28) in the back of the cab.

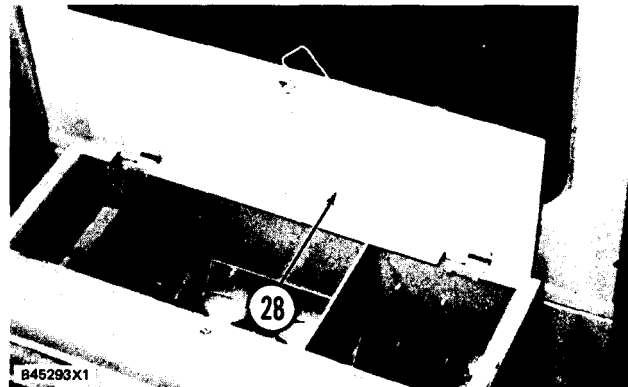

ENGINE AND TRANSMISSION

31. Install access door (29) to both sides of the machine.



32. Install muffler brackets (30) on the engine.

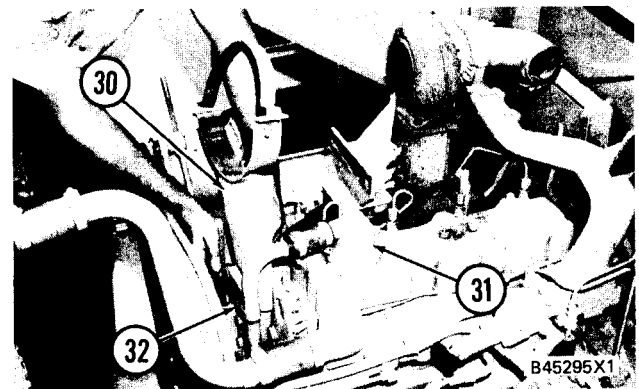

33. Install breather assembly (31) on the valve cover and tighten the bolt to a torque of 14 ± 3 N-m (10 ± 2 lb. ft.).

34. Connect clip (32) to the engine that holds the breather tube in place.

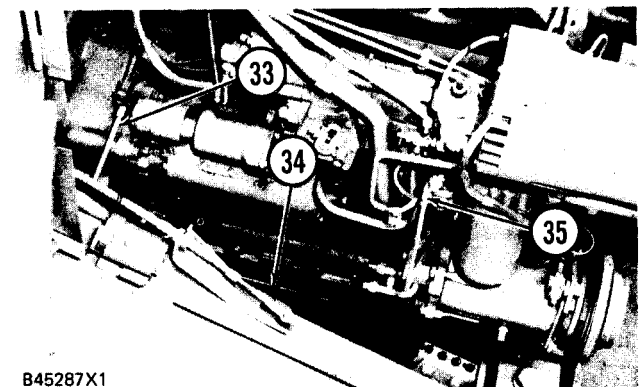

35. Connect fuel line (35) to the fuel injection pump housing.

36. Connect fuel line (35) to the fuel injection pump housing.

37. Connect clip (34) that holds the fuel line at the oil pan.

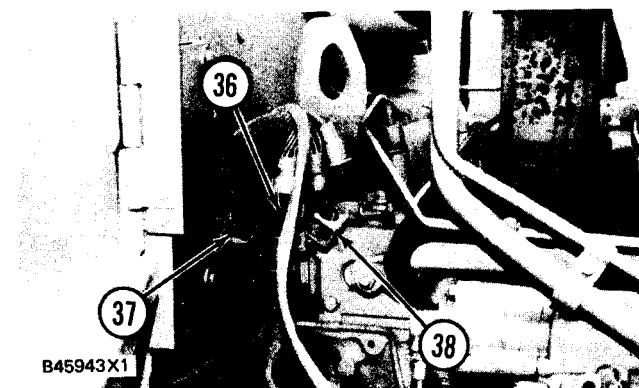

38. Connect wire harnesses (36), (37) and (38) at the rear of the engine.

ENGINE AND TRANSMISSION

- 39. For Models 950BNS and 950BS:
 - a) Connect bracket (39) to governor.
 - b) Connect cable assembly (40) to governor control lever.
- 40. For Models 950BNSCE and 950BSCE:
 - a) Install housing (46) and two screws.
 - b) Turn governor shaft clockwise to off position. Install lever (47) and bushings with lever approximately 35° forward of vertical.
 - c) Connect cable assembly (48) using washer and screw.
 - d) Install gasket, cover (49) and six screws.
- 41. Connect wires (41) to the solenoid and wires (42) to the starter.
- 42. Connect air lines (43) and (44) to the engine as shown.
- 43. Connect engine disconnect switch (45) to the frame.
end by:
 - a) install hood*
 - b) install muffler*

WARNING

If NBC exposure is suspected, all air filter media should be handled by personnel wearing protective equipment. Consult your unit NBC Officer or NBC NCO for appropriate handling or disposal instructions.

- c) install air cleaner housing*
- d) install radiator and guard*
- e) remove rear drive shaft
- f) remove center drive shaft

*This operation is in the ENGINE DISASSEMBLY AND ASSEMBLY section.

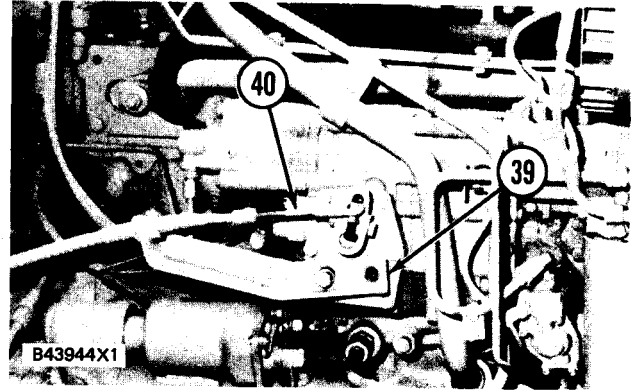

Models 950BNS and 950BS

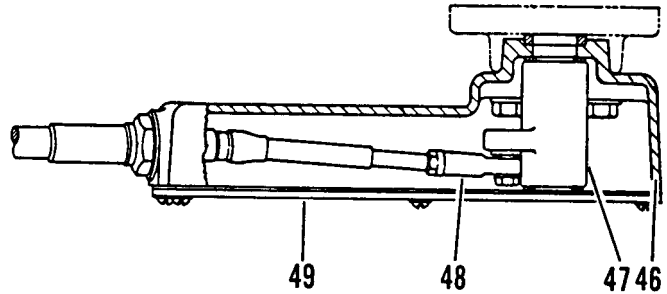

Models 950 BNSCE and 950BSCE

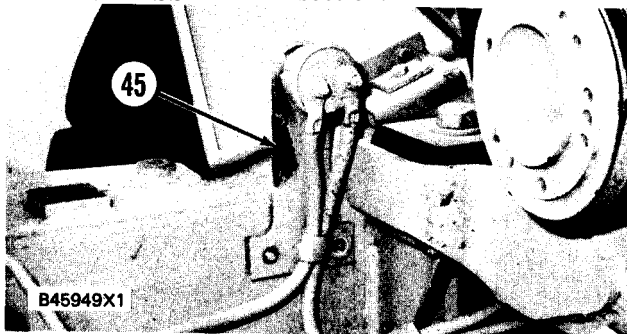
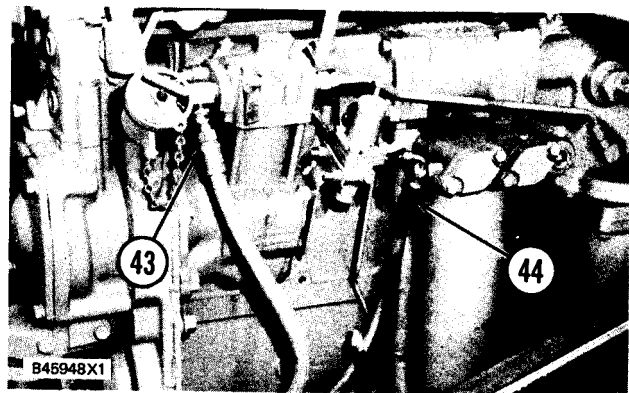
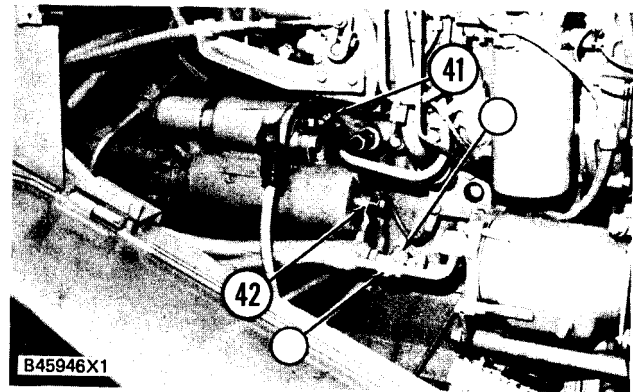

SEPARATION OF TORQUE CONVERTER AND TRANSMISSION FROM ENGINE

SEPARATION OF TORQUE CONVERTER AND TRANSMISSION FROM ENGINE 3000 & 1000-29

Tools Needed		A	B
9S8500	Engine Stand	1	
6V3145	Load Leveler		1

start by:

a) remove engine, torque converter and transmission

1. Put the engine, torque converter and transmission in position on tool (A) as shown.
2. Disconnect the wire from sending unit (1).
3. Remove tube assemblies (2) that connect the transmission oil cooler to the torque converter and the transfer gear case.
4. Install 3/4"-10 NC eyebolt (4) in the housing as shown.
5. Put tool (B) in position on transmission and torque converter.
6. Remove bolts (5) and make a separation of transmission and torque converter (3) from the engine. The weight of the transmission and torque converter is 743 kg (1650 lb.).

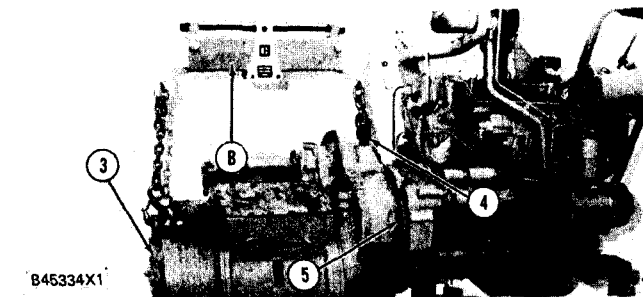
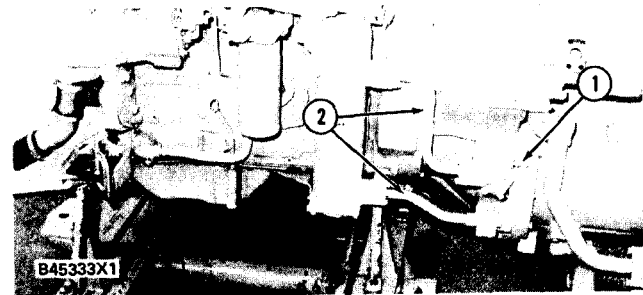
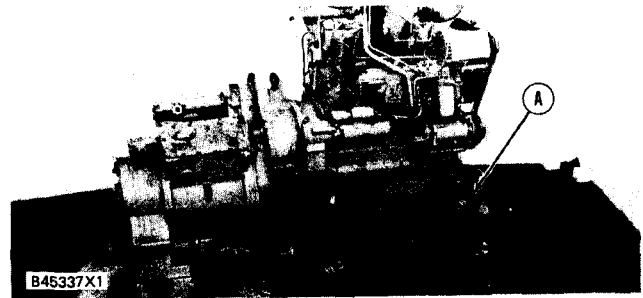

CONNECTION OF TORQUE CONVERTER AND TRANSMISSION TO ENGINE 3000 & 1000-29

Tools Needed		A	B
9S8500	Engine Stand	1	
6V3145	Load Leveler		1

1. Install a 3/4"-10 eyebolt (1) and put tool (B) in position on transmission and torque converter housing (3) as shown.
2. Install O-ring seal (2) on the transmission case.
3. Make an alignment of the flywheel and the torque connection of transmission and torque converter (3) to the engine. Install the bolts.
4. Connect the wire to sending unit (4).
5. Make sure the O-ring seals are in position on tube assemblies (5).
6. Install tube assemblies (5).

end by:

Install engine, torque converter and transmission

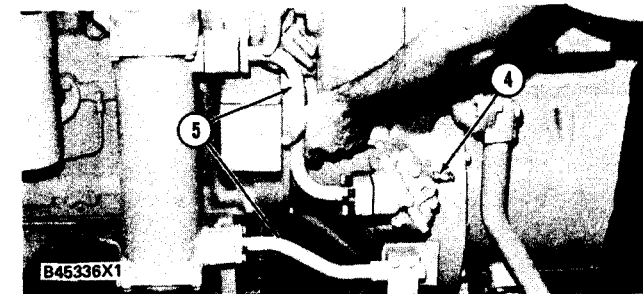
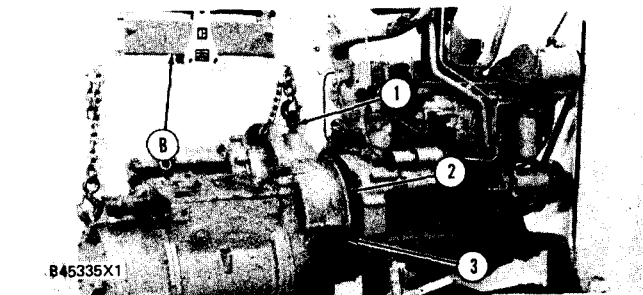

TORQUE CONVERTER

SEPARATION OF TORQUE CONVERTER FROM TRANSMISSION 3100-29

start by:

- a) remove torque converter, transmission and transfer gears

1. Fasten a hoist to hydraulic pump (1) as shown.
2. Remove the bolts and hydraulic pump (1) from the transmission oil pump. The weight of the pump is 36 kg (80 lb.).
3. Remove the bolts and tube assembly (2) from the transmission oil pump and the transfer gear case.
4. Remove the bolts and outlet relief valve (3) from the torque converter.
5. Remove the bolts and transmission oil pump (4) from the torque converter.
6. Put the torque converter, transmission and transfer gears in a vertical position on wood blocks with the torque converter up.
7. Fasten two 3/8"- 16 NC forged eyebolts (6) and a hoist to torque converter (5) as shown.
8. Remove the bolts and nuts and remove torque converter (5) from the transmission. The weight of the torque converter is 158 kg (350 lb.).

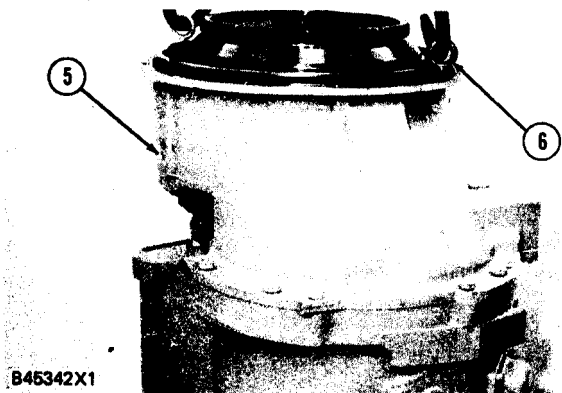
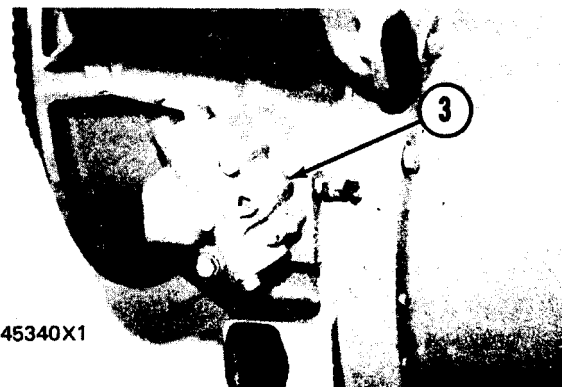
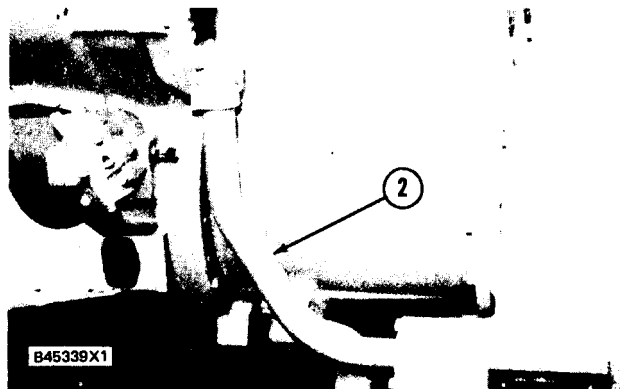
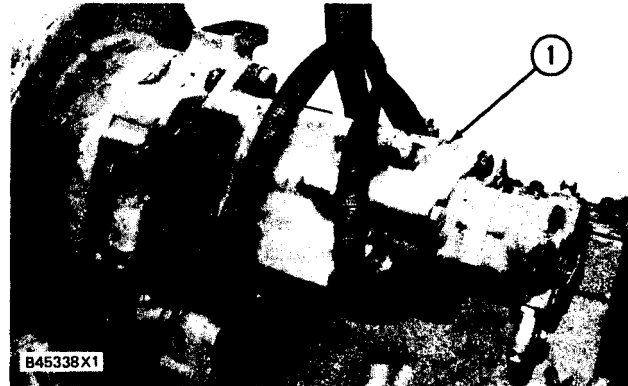

TORQUE CONVERTER

CONNECTION OF TORQUE CONVERTER TO TRANSMISSION 3100-29

1. Fasten two 3/8''-16 NC forged eyebolts (2) and a hoist to torque converter (1) as shown.
2. Make sure O-ring seal (3) is installed around the transmission case and put clean oil on it.
3. Lower torque converter (1) on to the transmission. Make sure dowels (4) on the transmission are in alignment with the holes in the torque converter.
4. Install O-ring seals (5) on transmission oil pump (6) and put clean oil on them.
5. Install transmission oil pump (6) on the torque converter.
6. Install O-ring seals (7) on outlet relief valve (8) and put clean oil on them.
7. Install outlet relief valve (8) on the torque converter.
8. Install the O-ring seals on both ends of tube assembly (9) and put clean oil on them.
9. Install tube assembly (9) on the transmission oil pump and the transfer gear case.
10. Fasten a hoist to hydraulic pump (10) as shown.
11. Put the O-ring seal in position on the hydraulic pump and put clean oil on it.
12. Install hydraulic pump (10) on the transmission oil pump.
 - a) install torque converter, transmission and transfer gears

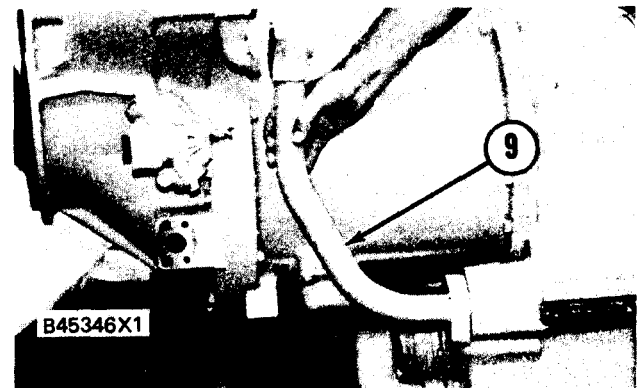
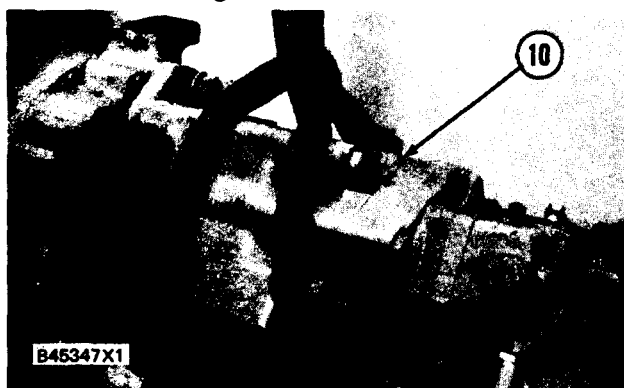
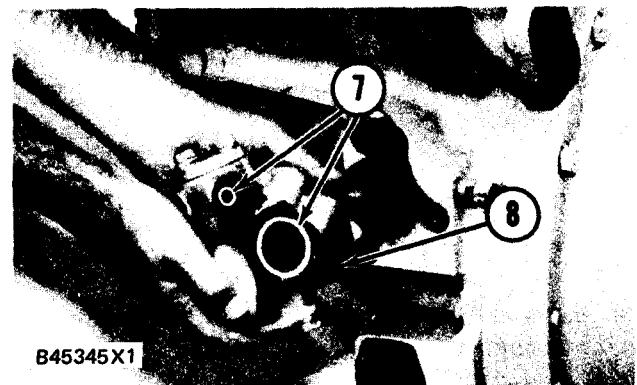
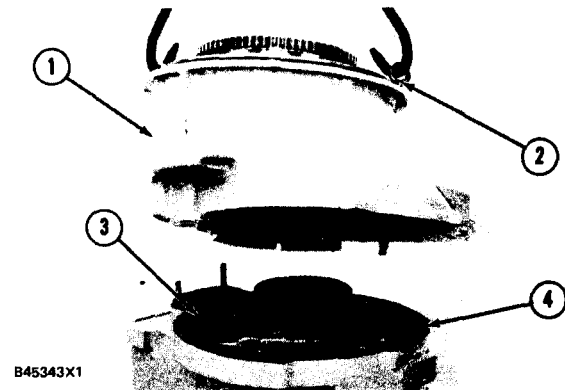

TORQUE CONVERTER

DISASSEMBLE TORQUE CONVERTER 3100-15

Tools Needed		A	B	C	D
5P9736	Link Bracket	2			
1H3107	Puller Assembly		1		
8B7554	Bearing Cup Puller Attachment		1		
5P4750	Screw		1		
8H684	Ratchet Box Wrench		1		
1S5188	Leg		2		
5F7344	Block		1		
2P8312	Pliers			1	
1P2321	Puller Assembly				1
9S9154	Step Plate				1

start by:

a) separation of torque converter from transmission

1. Install tool (A) and a hoist on housing (2) as shown.
2. Remove eight bolts (1) and remove housing (2) from the torque converter. The weight of the housing is 95 kg (210 lb.).
3. Remove bolts (3) and flange (4) from the gear.
4. Remove bolt (5) that holds the shaft to the housing.
5. Install 3/8"- 16 NC forged eyebolts (6) in gear (7).
6. Lift gear (7), shaft (8), the cone and spacer enough so shaft (8) is clear of the bore in the housing.
7. Move the assembly slightly over and lower it so shaft (8) is no longer in the bore of the housing.

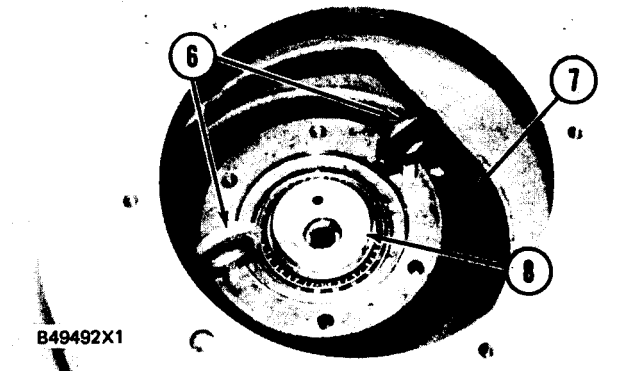
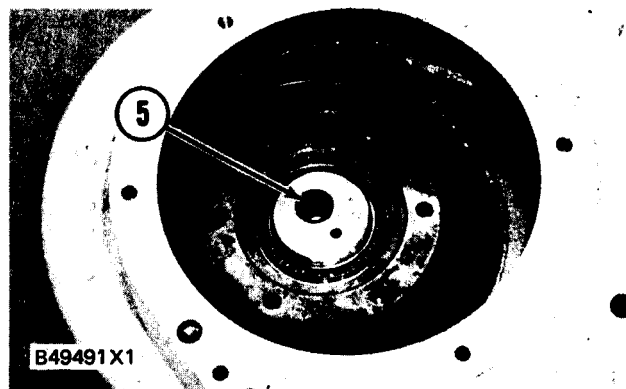
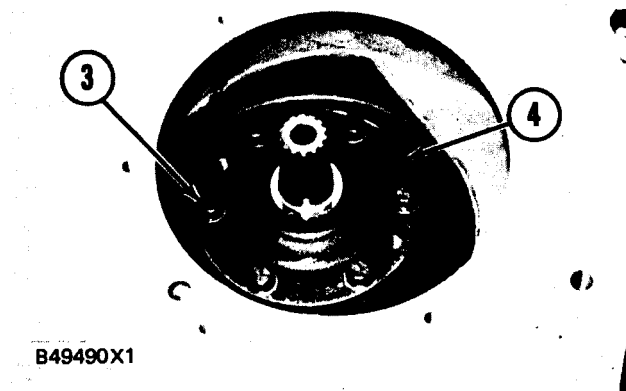
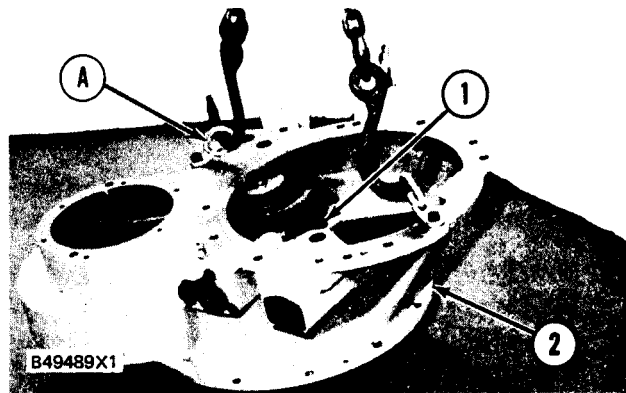

TORQUE CONVERTER

8. Remove eyebolts (6) from gear (7).
9. Remove shaft (8), bearing cones (9) and the spacer from gear (7).

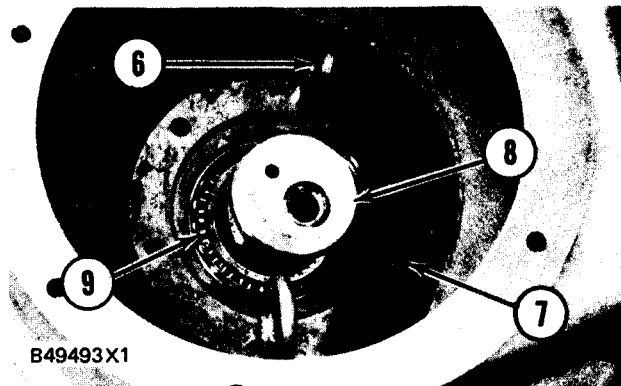

10. Use tooling (B) to remove bearing cups (10) from each side of gear (7).

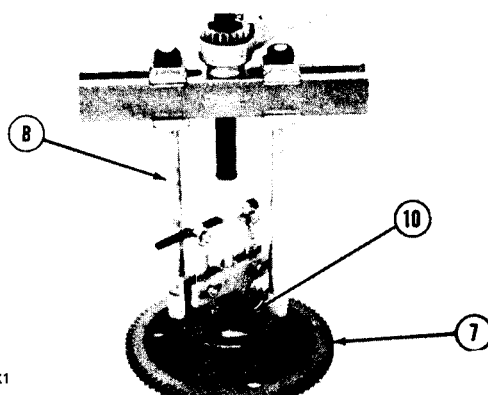

11. Remove ring (11) from the gear.

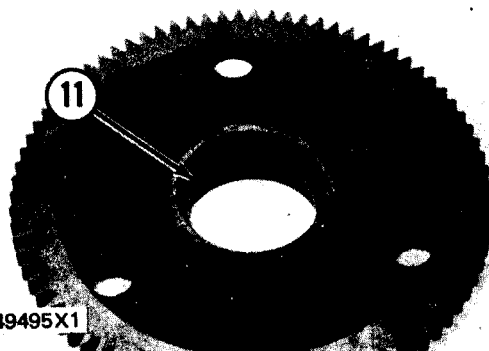

12. Remove O-ring seals (15) from carrier (16).

13. Remove bolt (12), retainer (13) and gear (14).

14. Remove ring (17) that holds the shaft and bearing to the carrier.

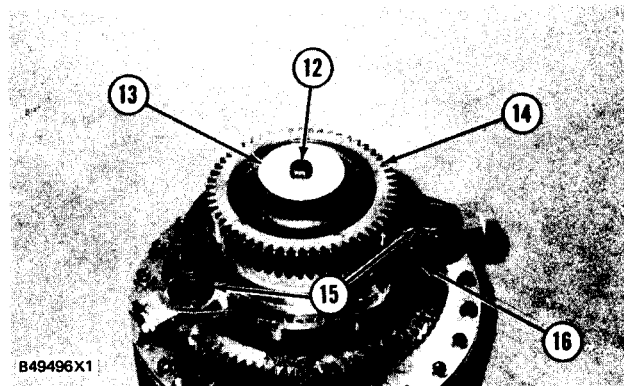
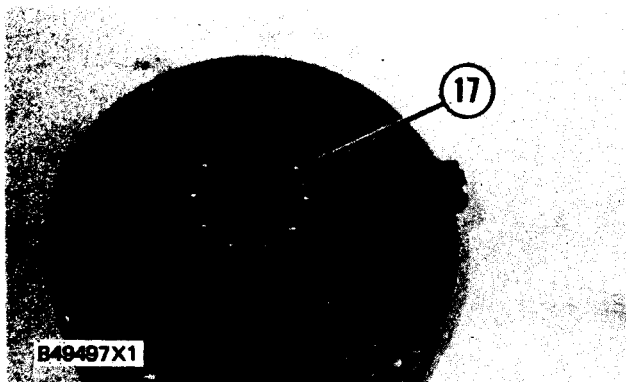

TORQUE CONVERTER

15. Install retainer (13) and one of tool (A) and a hoist on shaft (18).

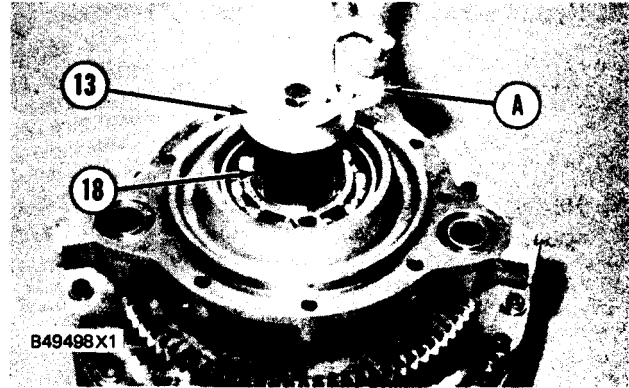

16. Lift up slightly on shaft (18) and the bearing. Use a rubber hammer and tap the carrier to free the shaft and bearing.

17. Remove ring (19) from shaft (18).

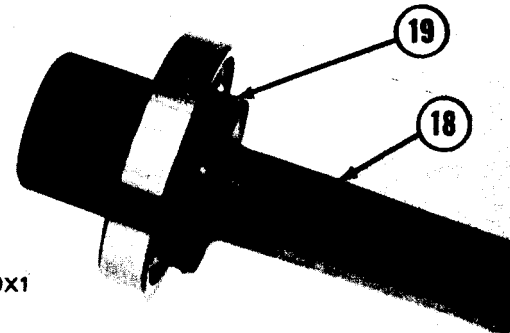

18. Use tool (C) to remove ring (20) from shaft (18).

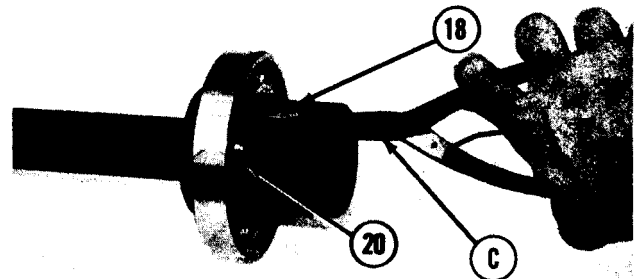

19. Use a press and push shaft (18) from bearing (21).

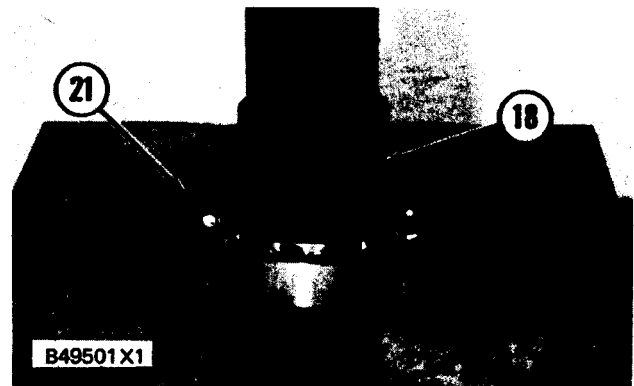

20. Remove bolts (22) that hold the impeller, plate and housing together.

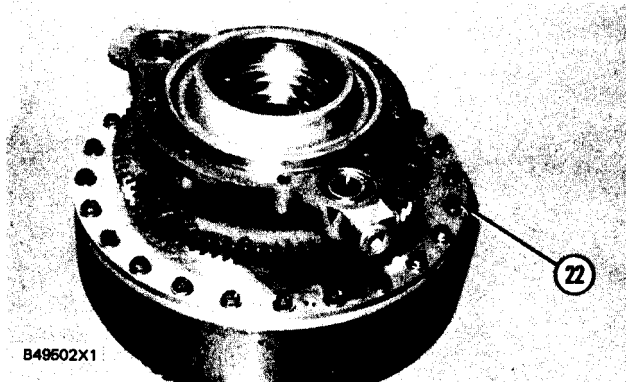

TORQUE CONVERTER

21. Install two 3/8"- 16 NC forged eyebolts (23) and a hoist to make a separation of the impeller and the carrier from the housing.

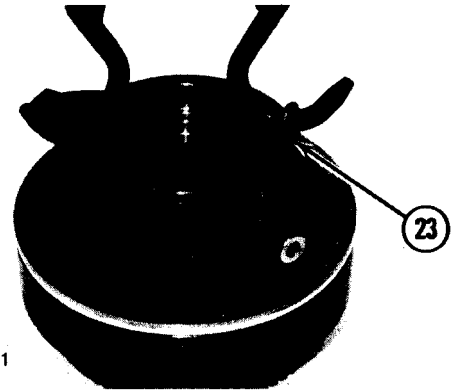

22. Use tool (C) to remove ring (24) from the carrier.

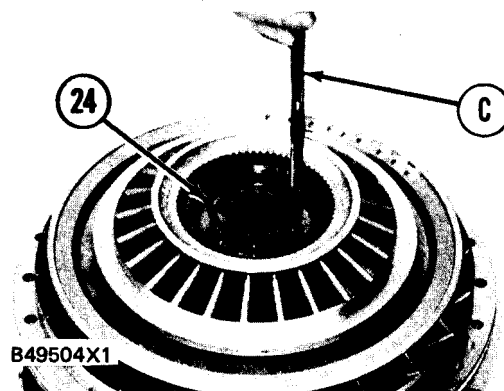

23. Use tool (D) to carefully remove stator (25) from the impeller and the carrier.

24. Remove rings (26) from each side of adapter (27).

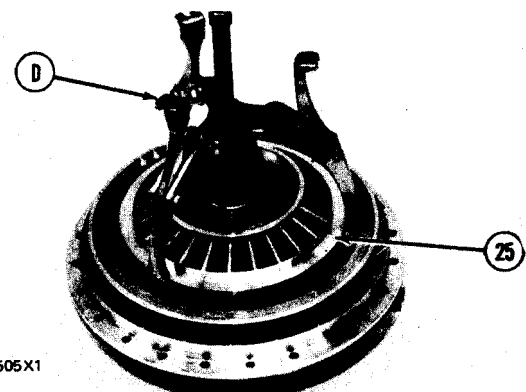

25. Heat stator (25) and adapter (27) at 1210 C (250° F) and remove adapter (27) from stator (25).

26. Remove retainer (29), two races (28) and the bearing from the impeller.

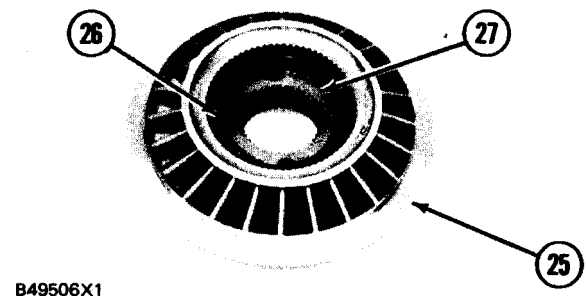
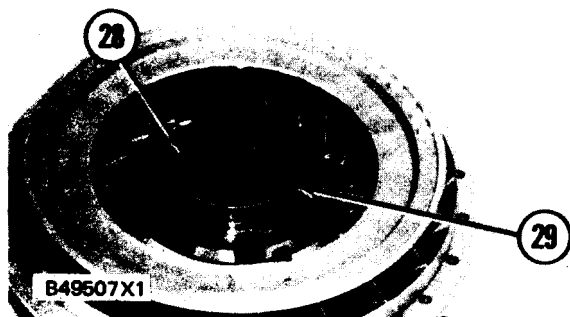

TORQUE CONVERTER

27. Remove impeller (30), the plate and the gear from the carrier.



28. Remove bolts (31) and hub (32) from the impeller.

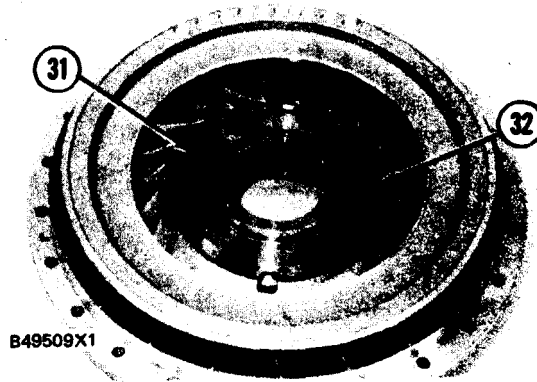

29. Remove impeller (30) from the plate and the gear.

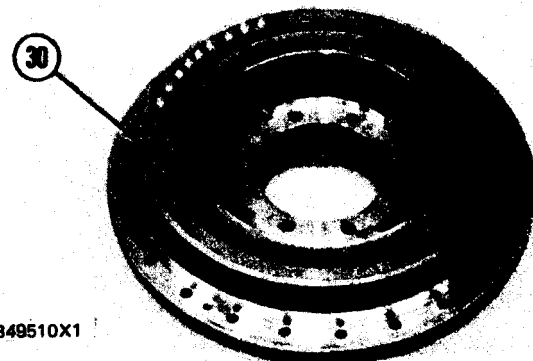

30. Remove plate (33) from the gear.

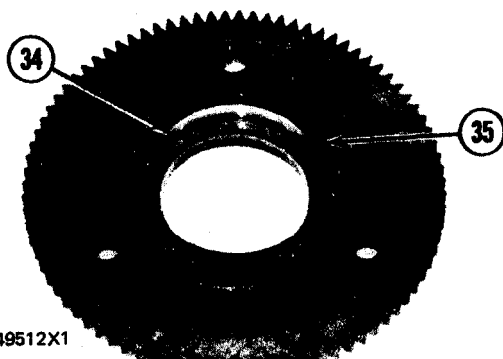

31. Remove ring (35) and race (34) from the gear.

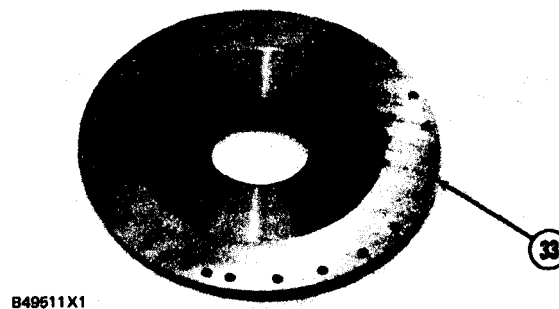

TORQUE CONVERTER

32. Use tool (C) to remove ring (36) from the carrier.

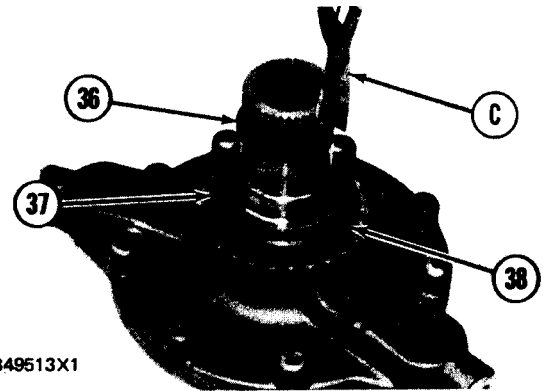

33. Remove rings (37) and (38) from the carrier.

34. Remove bearing (39) and carrier (40) from the carrier.

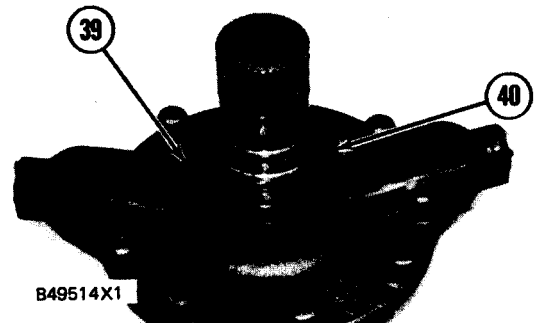

35. Remove plug (41) from both ends of the carrier.

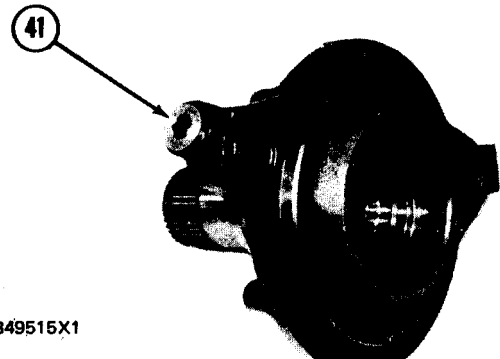

36. Remove the ring and sleeve (42) from the carrier.

NOTE: Some earlier models can have two rings.

37. Remove retainer (44), two races (43) and the bearing from the turbine.

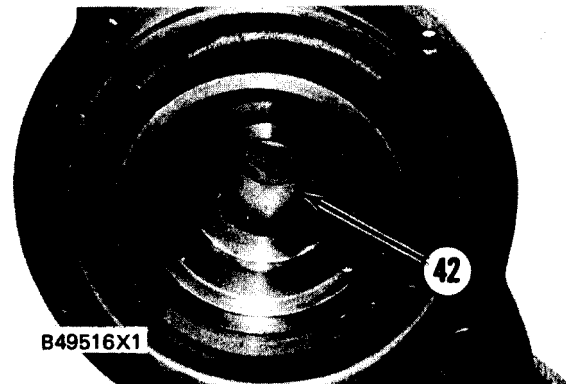
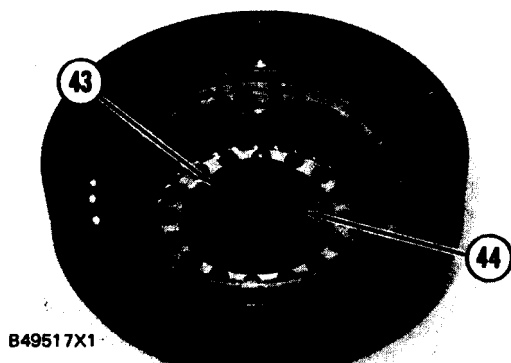

TORQUE CONVERTER

38. Remove turbine (45) from the housing.

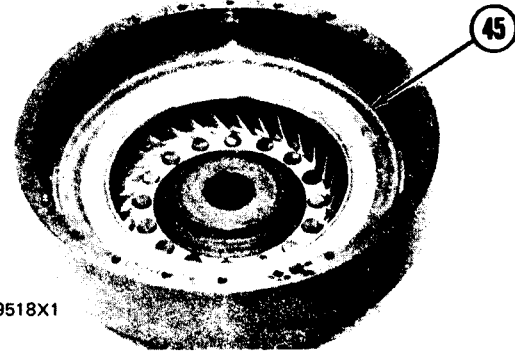

B49518X1

39. Remove retainer (47), two races (46) and the bearing from the housing.

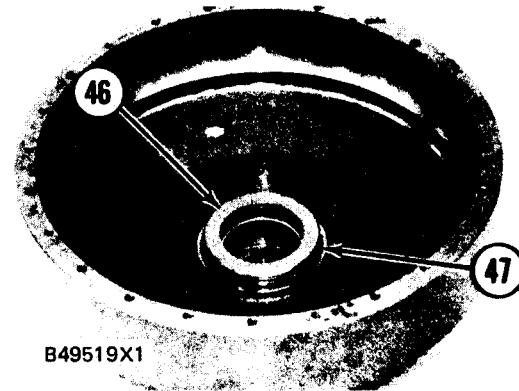

B49519X1

ASSEMBLE TORQUE CONVERTER 3100-16

Tools Needed		A	B	C
1P8312	Pliers	1		
1P520	Driver Group		1	
5P9736	Link Bracket			2

1. Install retainer (4) (with the lip down), race (2), bearing (3) and race (1) in the housing.

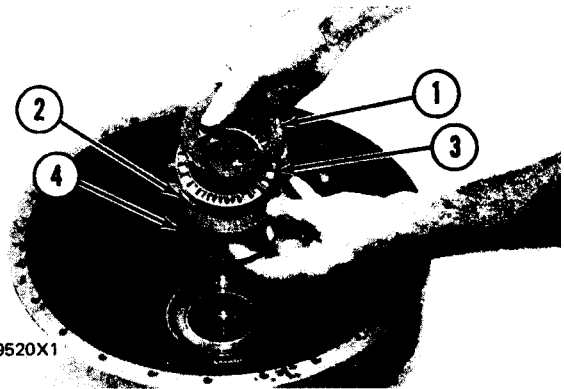

B49520X1

2. Install turbine (5) in the housing as shown.

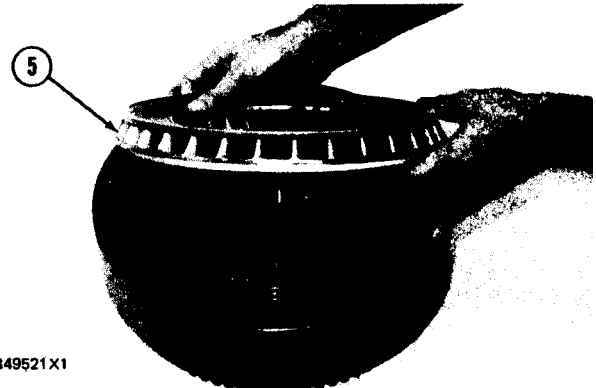

B49521X1

3. Install race (9), bearing (8), race (7) and retainer (6) (with the lip up) on the turbine.

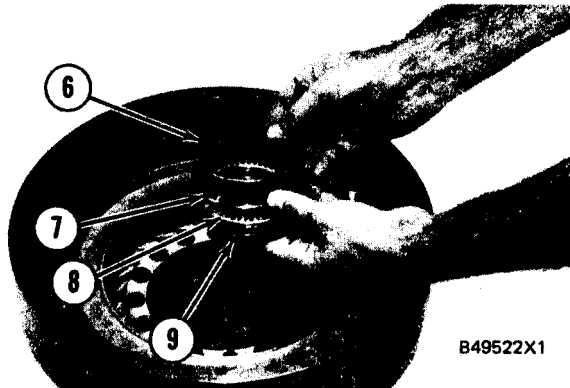

B49522X1

POWER TRAIN

TORQUE CONVERTER

4. Install sleeve (10) and ring (11) in the carrier as shown.

NOTE: Some earlier models can have two rings (11).

5. Install O-ring seals (12) on plugs (13).

6. Install plugs (13) in both sides of the carrier.

7. Heat bearing (15) to a maximum temperature of 135° C (275° F) and install it on the carrier.

8. Heat carrier (14) to a maximum temperature of 135°C (275° F) and install it on the carrier.

9. Install rings (17) and (18) on the carrier.

10. Use tool (A) to install ring (16) on the carrier.

11. Lower the temperature of race (20) and install it in gear (21).

12. Install ring (19) on gear (21).

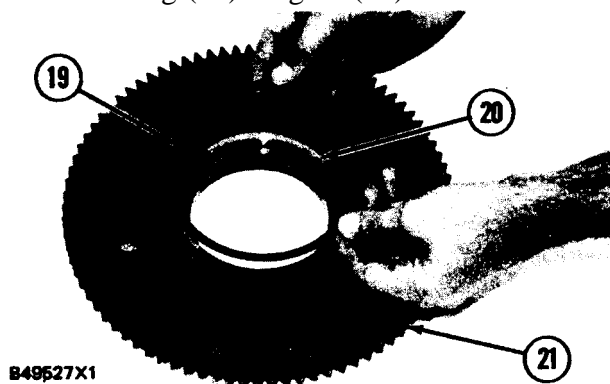
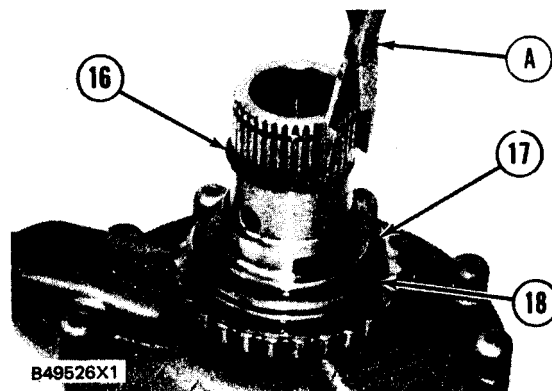
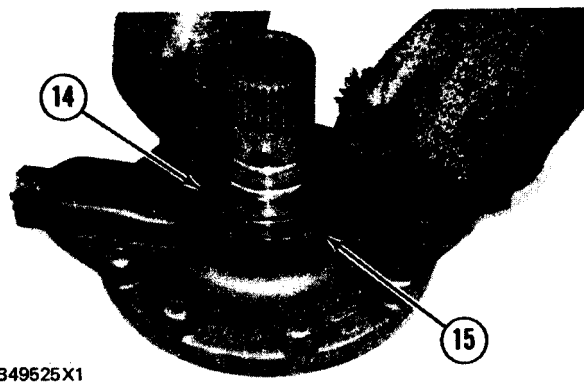
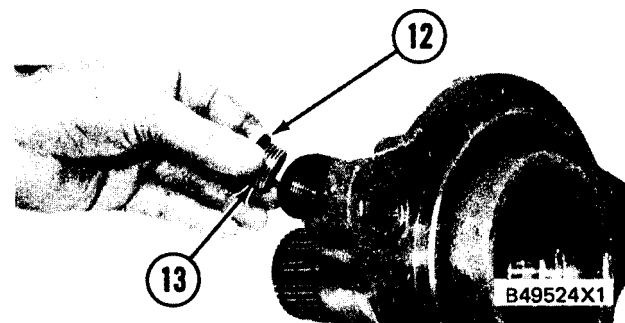
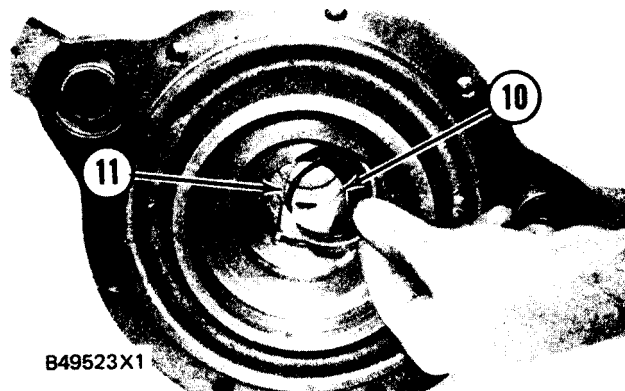

TORQUE CONVERTER

13. Put plate (23) and impeller (22) in position on gear (21).

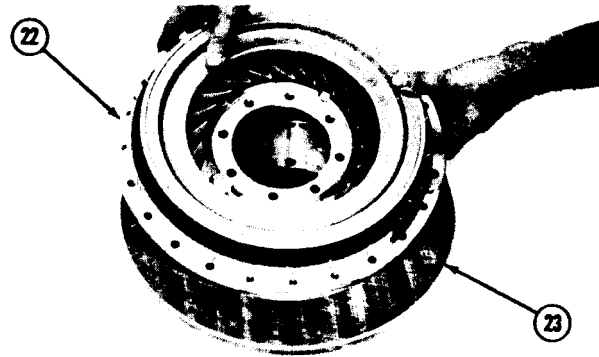

B49528X1

14. Put hub (24) in position on the impeller.

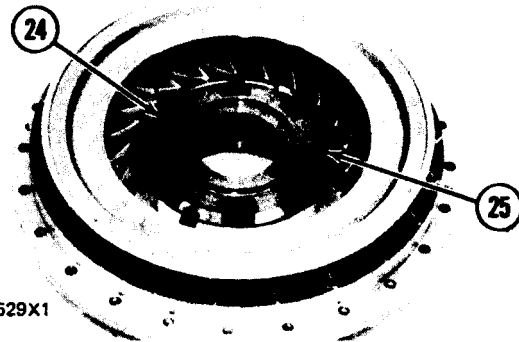

B49529X1

15. Install bolts (25) that hold the hub, impeller, plate and the gear together. Tighten the bolts to a torque of $50 \pm 3 \text{ N}\cdot\text{m}$ ($37 \pm 2 \text{ lb. ft.}$).

16. Install impeller (22) on carrier (26).

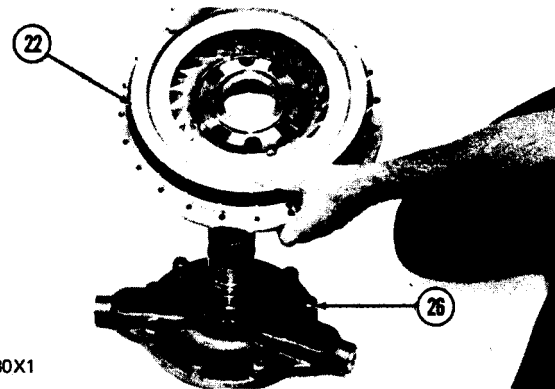

B49530X1

17. Install race (30), bearing (29), race (28) and retainer (27) (with the lip up) on the hub.

18. Heat stator (32) to a maximum temperature of $121 \text{ }^\circ\text{C}$ ($250 \text{ }^\circ\text{F}$) and install it on adapter (31). Make sure the adapter is in the center of the stator.

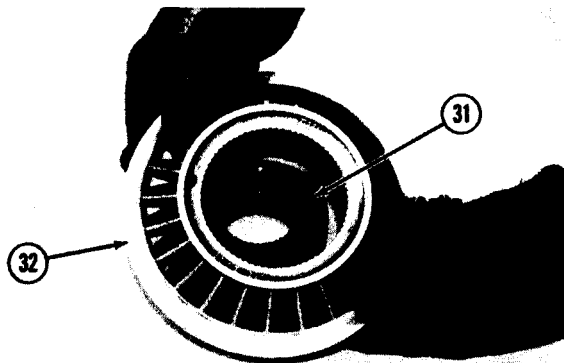

B49532X1

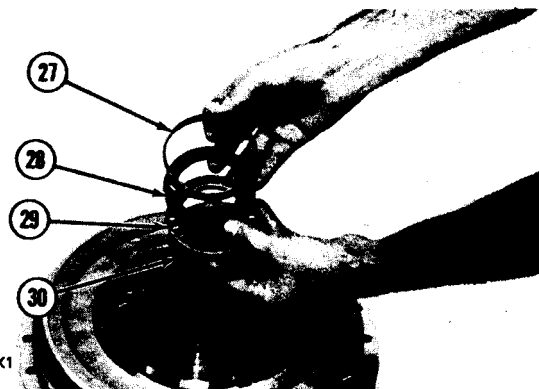

B49531X1

TORQUE CONVERTER

19. Install rings (33) on both sides of the stator.

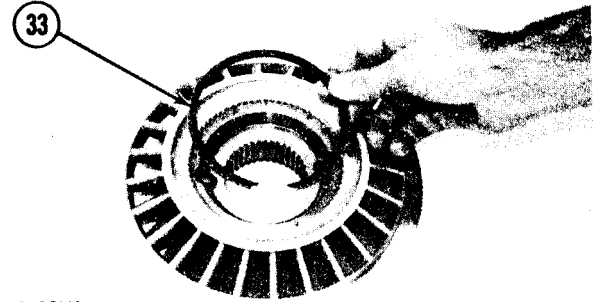

20. Install stator (32) on impeller (22).

B49533X1

21. Install ring (34) on the shaft as shown.

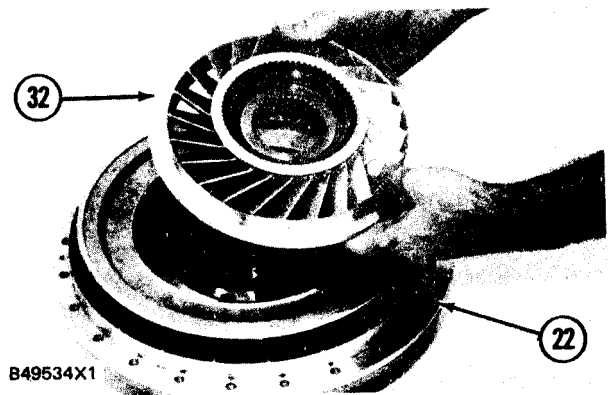

B49534X1

22. Install two 3/8"- 16 NC forged eyebolts (35) and a hoist in the carrier. Put the carrier and the impeller in position in the housing as shown.

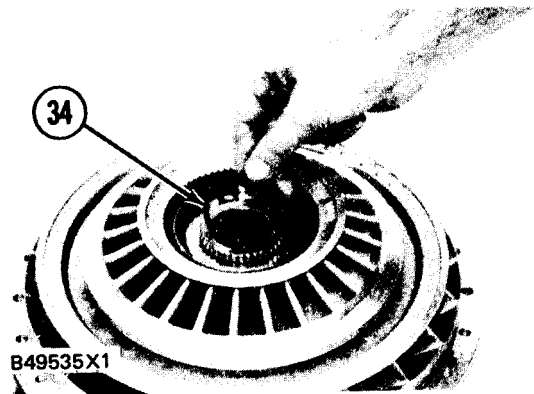

B49535X1

23. Install bolts (36) that hold the carrier and the impeller in the housing. Tighten the bolts to a torque of 27 ± 2 N•m (20 ± 1 lb. ft.).

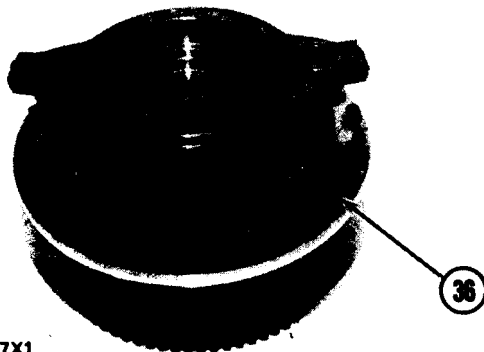

B49537X1



B49536X1

TORQUE CONVERTER

24. Use a press and install shaft (37) in bearing (38).

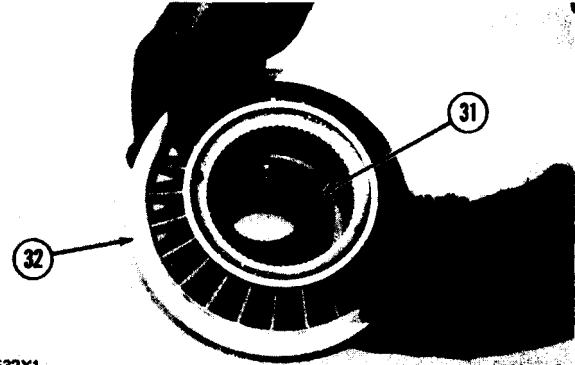

25. Use tool (A) to install ring (39) on the shaft.

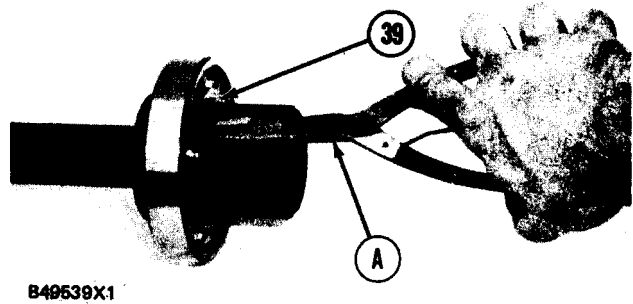

26. Install ring (40) in the groove on the shaft.

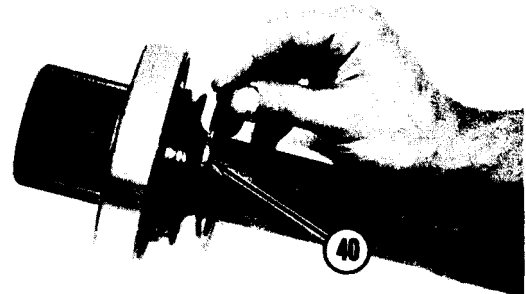

27. Install shaft (37) and the bearing in position in the carrier as shown.

28. Install ring (41) in the carrier to hold the bearing and shaft in place.

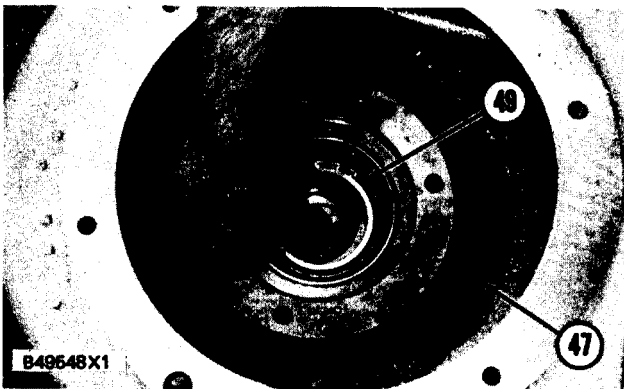

TORQUE CONVERTER

29. Install O-ring seals (42) in the carrier.

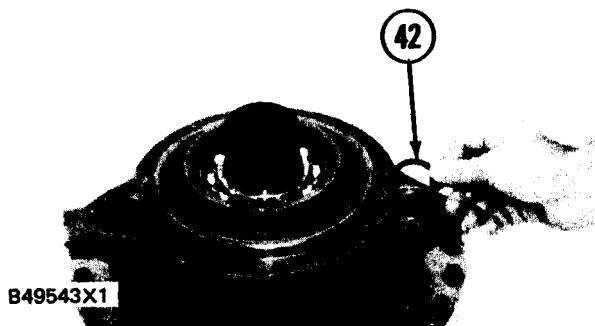

30. Install gear (43) on the shaft as shown.

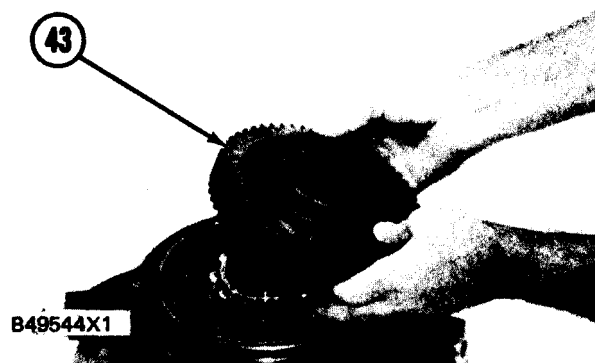

31. Install retainer (45) and bolt (44) in the shaft. Tighten the bolt to a torque of $110 \pm 10 \text{ N}\cdot\text{m}$ ($80 \pm 7 \text{ lb. ft.}$).

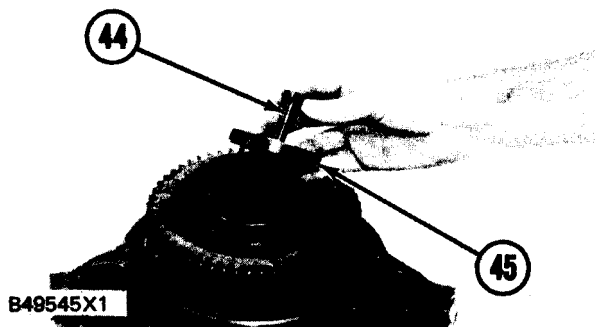

32. Install ring (46) in gear (47).

33. Use tool (B) to install bearing cups (48) in both sides of the gear.

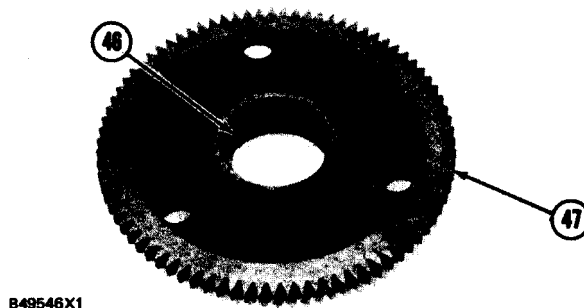
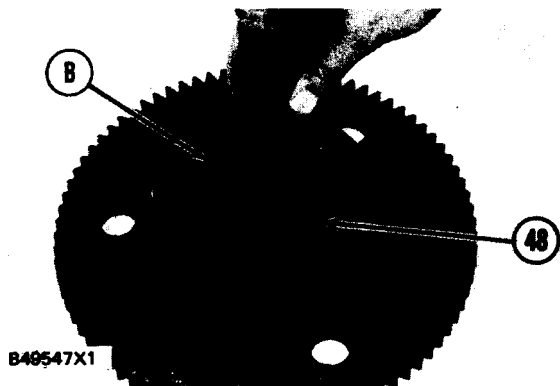

TORQUE CONVERTER

34. Install bearing (49) in gear (47).

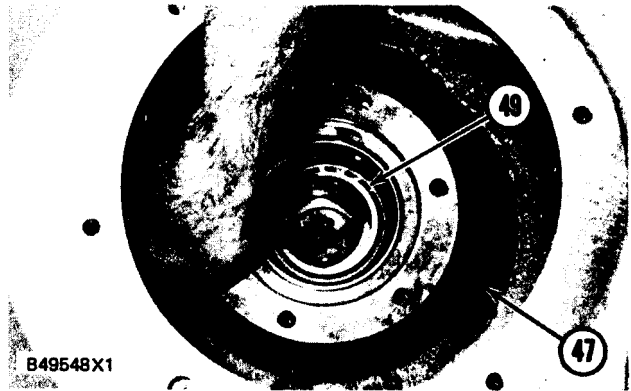

35. Put gear (47) into position in the housing as shown.

36. Install spacer (50) and bearing (52) on shaft (51) as shown.

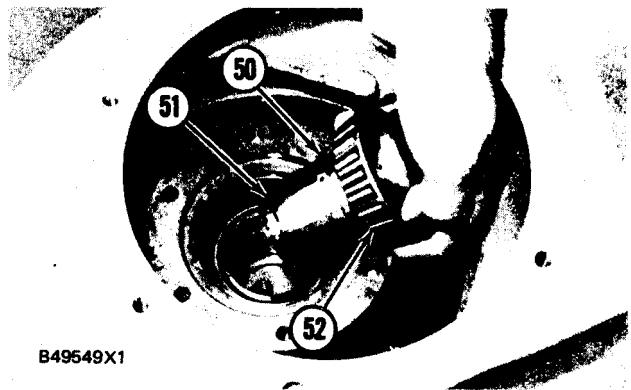

37. Install shaft (51) in the gear. Make sure shaft (51) fits into the bore of the housing.

38. Install bolt (53) in shaft (51). Tighten the bolt to a torque of $100 \pm 5 \text{ N}\cdot\text{m}$ ($75 \pm 5 \text{ lb. ft.}$). Rotate gear when tightening to seat bearing.

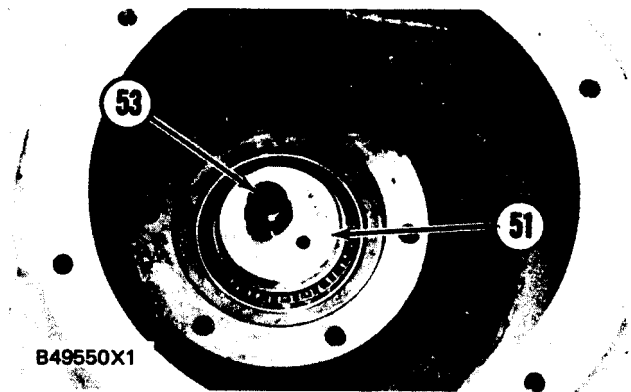

39. Put flange (55) in position on the gear and install bolts (54). Tighten the bolts to a torque of $50 \pm 3 \text{ N}\cdot\text{m}$ ($37 \pm 2 \text{ lb. ft.}$).

40. Install tooling (C) and a hoist on the housing as shown.

41. Put the housing in position on the torque converter and install bolts (56).

end by:

a) connection of torque converter to transmission

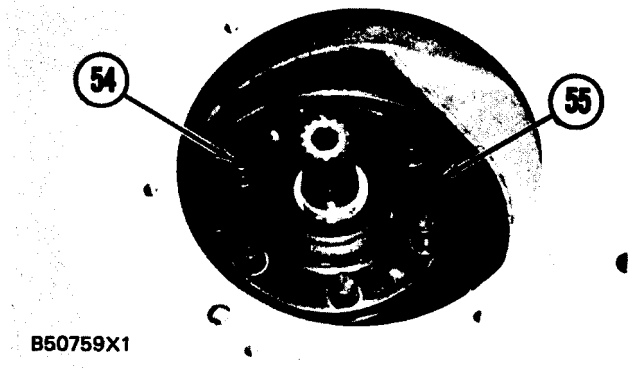

TRANSMISSION HYDRAULIC CONTROL VALVES

REMOVE TRANSMISSION HYDRAULIC CONTROL VALVES 3152-11

Tools Needed		A
FT527	Lifting Bracket	1

start by:

- a) remove seat (see OPERATOR'S STATION DISASSEMBLY AND ASSEMBLY section)

1. Remove the covers and windshield washer bottle from under the operator's seat.
2. Disconnect the transmission neutralizer from the hydraulic control valve. See REMOVE TRANSMISSION NEUTRALIZER in the VEHICLE SYSTEMS DISASSEMBLY AND ASSEMBLY section.
3. Remove the bolts and disconnect opening (slot) on the speed selector from the notch on the selector spool.

NOTE: The torque converter transmission and transfer gears are removed for a better photo illustration.

4. Remove cover assembly (1) and the gasket from the transmission case.
5. Remove bolt (3) and the washer. Push sleeves (2) and (4) into the torque converter to disconnect them from the valve body.
6. Remove adapter (5) and the spring from the transmission case.
7. Install a ½"- 13 NC forged eyebolt (6) in the sleeve as shown. Remove the sleeve from the transmission case.

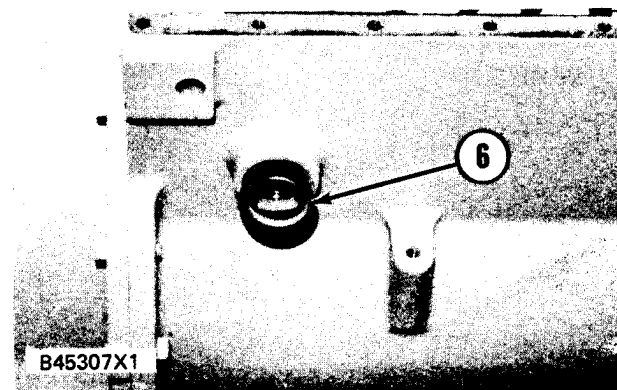
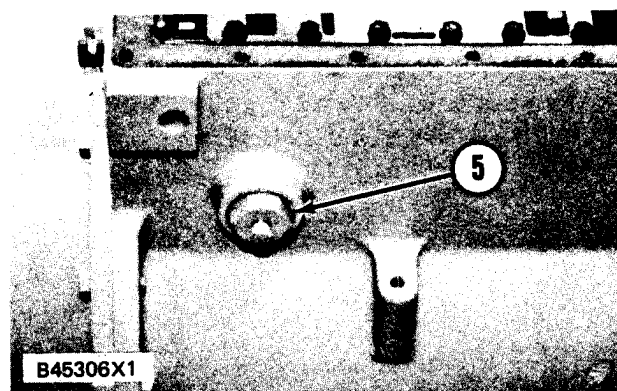
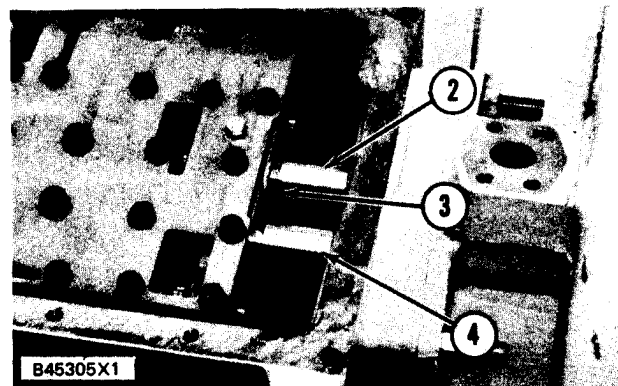
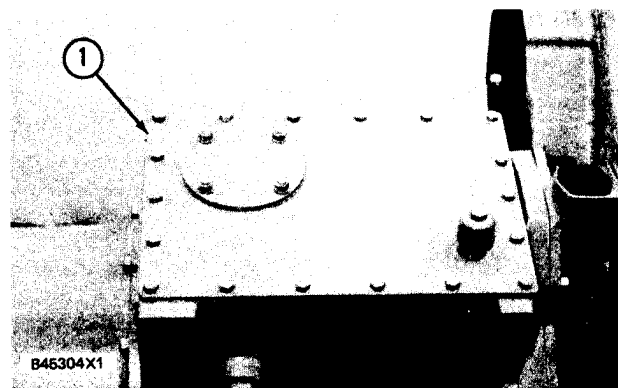

TRANSMISSION HYDRAULIC CONTROL VALVE

8. Remove O-ring seals (7) from sleeve (8).

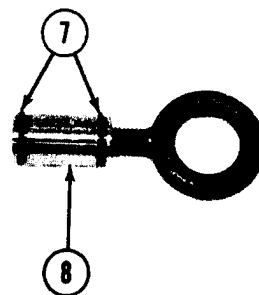

B45308X1

9. Put tool (A) and a hoist in position as shown.

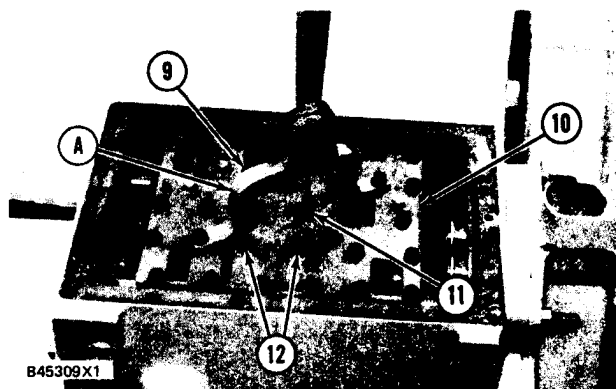

10. Loosen and disconnect bolt (11) from the transmission.

11. Remove bolts (9) and (12) and transmission hydraulic control valve (10) from the transmission. The weight of the valve is 32 kg (70 lb.).

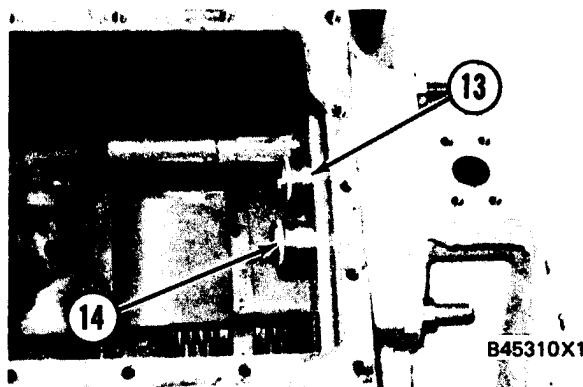

12. Remove sleeves (13) and (14) from the transmission case.

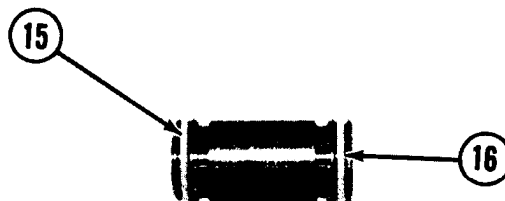

B45311X1

13. If necessary remove O-ring seals (15) and (16) from the sleeves.

TRANSMISSION HYDRAULIC CONTROL VALVE

INSTALL TRANSMISSION HYDRAULIC CONTROL VALVES 3152-12

	Tools Needed	A
FT527	Lifting Bracket	1

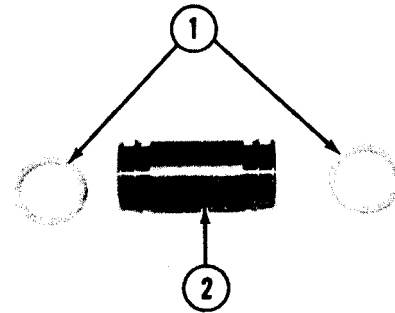

B45312X1

1. Install O-ring seals (1) on sleeves (2).

2. Put clean transmission oil on the O-ring seals and install sleeves (2) in the transmission case as shown.

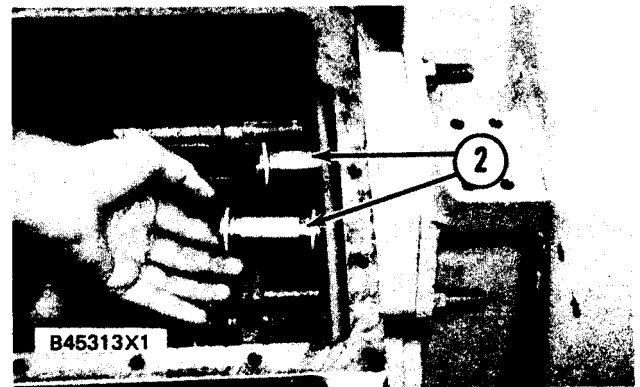

3. Fasten tool (A) and a hoist to transmission hydraulic control (3) as shown.

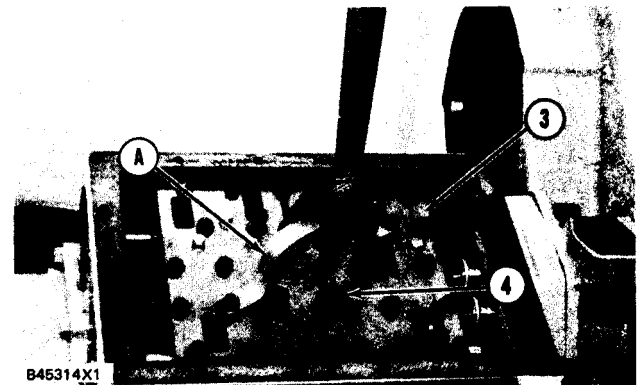

4. Put transmission hydraulic control (3) in position on the transmission and install bolts (4). Tighten the bolts to a torque of $48 \pm 4 \text{ N}\cdot\text{m}$ ($35 \pm 3 \text{ lb. ft.}$).

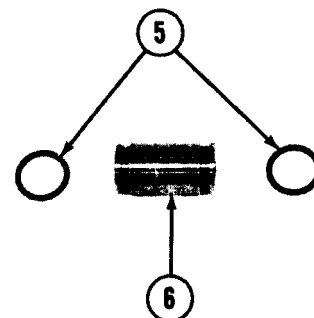

B45315X1

5. Install O-ring seals (5) on sleeve (6).

TRANSMISSION HYDRAULIC CONTROL VALVES

6. Put clean transmission oil on the seals. Install a ½"-13 NC forged eyebolt (7) on sleeve (6).
7. Install sleeve (6) into the transmission case and the control valve as shown.
8. Install spring (8) in the sleeve.
9. Install the O-ring seal on adapter (9) and put clean transmission oil on it.
10. Install adapter (9) in the transmission case.
11. Push sleeves (2) into the transmission hydraulic control valves and install the washer and bolt (10) that holds the sleeves in place.
12. Install gasket and plate (11) on the transmission case and install the bolts that hold it.
13. Connect the transmission neutralizer to the valve spool. See **INSTALL TRANSMISSION NEUTRALIZER** in the **DISASSEMBLY AND ASSEMBLY** section.
14. Connect the opening (slot) on the speed selector to the notch on the valve spool.
15. Make an adjustment to the transmission neutralizer and the speed selector control. See **POWER SHIFT TRANSMISSION, TESTING AND ADJUSTING** section.
16. Install the covers and windshield washer bottle that go under the operator's seat. end by:
 - a) install seat (see **OPERATOR'S STATION DISASSEMBLY AND ASSEMBLY** section)

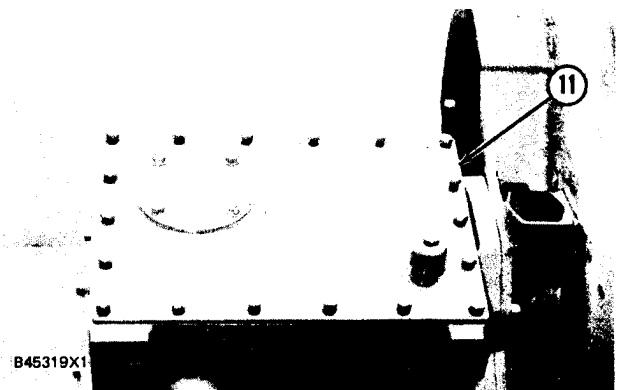
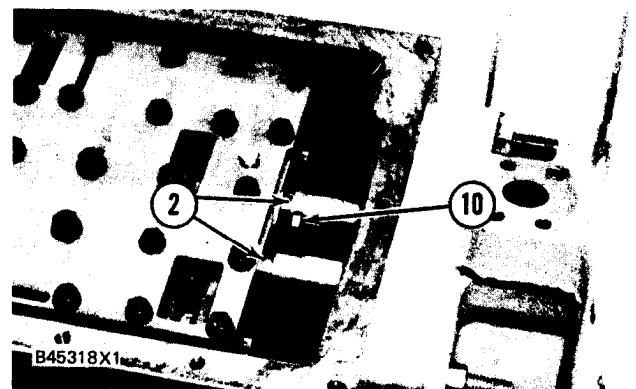
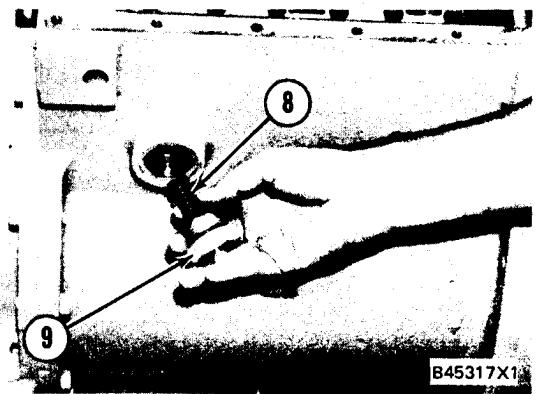
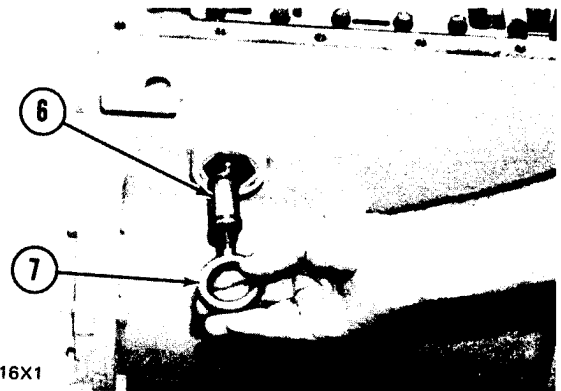

TRANSMISSION HYDRAULIC CONTROL VALVES

DISASSEMBLE TRANSMISSION HYDRAULIC CONTROL VALVES 3152-15

start by:

a) remove transmission hydraulic control valves

1. Remove twenty-six bolts (1) and the washers to remove plate (2) from the valve group.

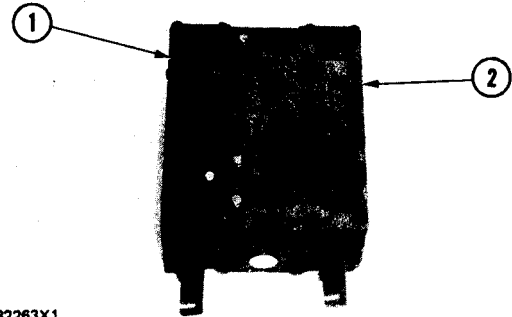

2. Remove valve group (3) from the plate and neutralizer valve group.

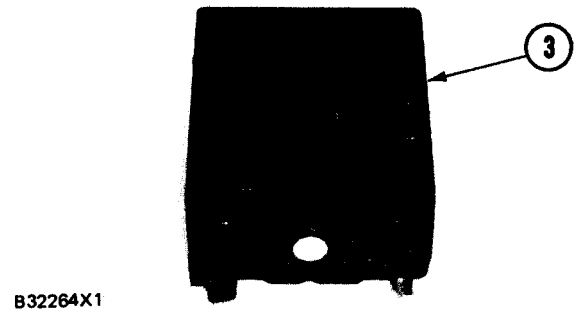

3. Remove two detent assemblies (4) from each side of the valve group. Remove the O-ring seals from the detent assemblies.

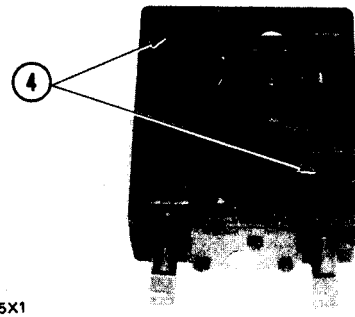

4. Remove two pins (5) and two stops (6) from the valve body.

5. Remove directional control valve spool (7) and speed control valve spool (8) from the valve body.

B32267X1

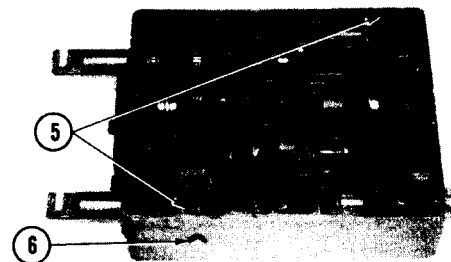
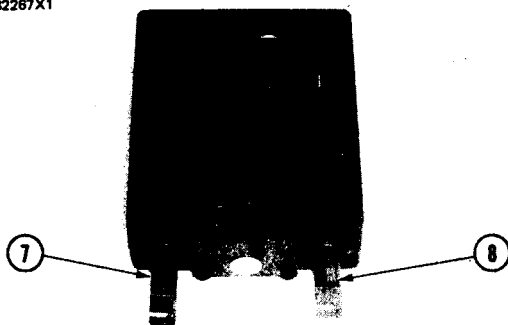

B32266X1

TRANSMISSION HYDRAULIC CONTROL VALVES

6. Remove cover (9) from the valve body.

7. Remove spring (10) and the valve spool from the valve body.



B32268X1

WARNING

Retainer (12) and the ring have spring pressure on them. Use care to prevent injury when the retainer is removed from valve spool (11).

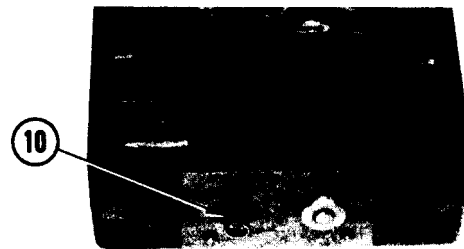

B32269X1

8. Remove spring (10) from retainer (12). Remove the ring that holds retainer (12) in valve spool (11). Remove retainer (12) and the two springs from valve spool (11).

9. Remove piston (13) and the two springs from the valve body.

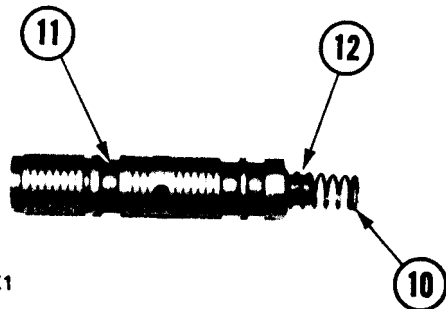

B32270X1

10. Remove springs (14) and the spacers (shims) from piston (13).

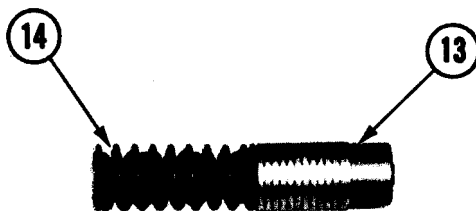

B32272X1

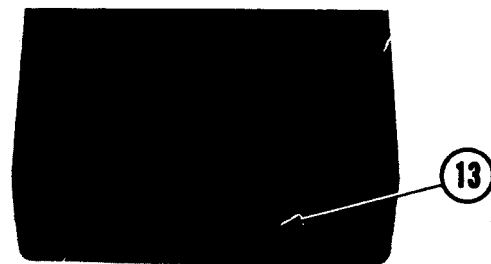

B32271X1

TRANSMISSION HYDRAULIC CONTROL VALVES

11. Remove valve spool assembly (16) from the valve body. If necessary, remove dowel (15) and the stop from the valve body.

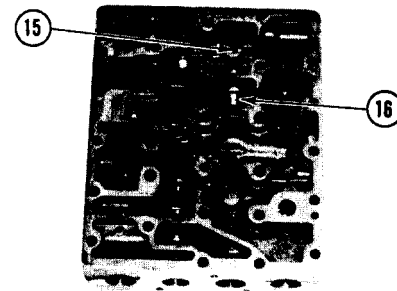

B32273X1

WARNING

The ring that holds the retainer in valve spool assembly (16) has spring force on it. Use care to prevent injury when the ring is removed.

12. Remove slug (17), the ring, retainer, spring and ball from the valve spool.

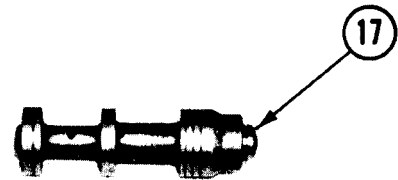

B32274X1

13. Remove dowel (18) and the stop to remove valve spool (19) from the valve body.

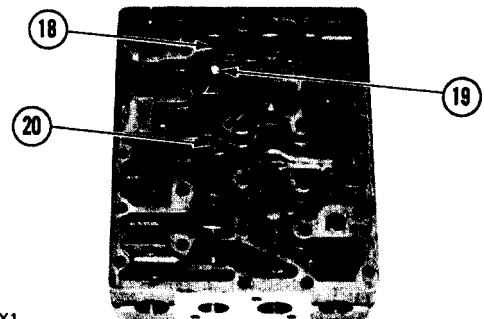

B32275X1

14. If necessary, remove dowel (20) and the stop from the valve body.

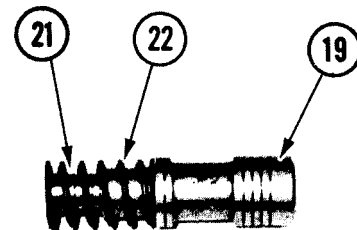

15. Remove slug (21) and spring (22) from valve spool (19).

B32276X1

TRANSMISSION HYDRAULIC CONTROL VALVES

16. Remove plate (23) from the neutralizer valve manifold.

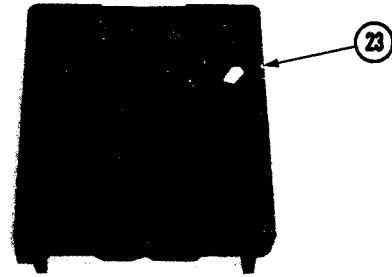

B32277X1

17. Remove dowel (26) to remove neutralizer valve spool (25) and spring (24) from the neutralizer manifold.

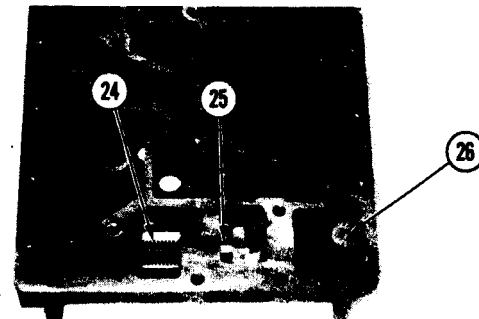

B32278X1

ASSEMBLE TRANSMISSION HYDRAULIC CONTROL VALVES 3152-16

1. Install spring (1) and valve spool (2) in the neutralizer manifold as shown. Install dowel (3) to hold valve spool (2) in position.

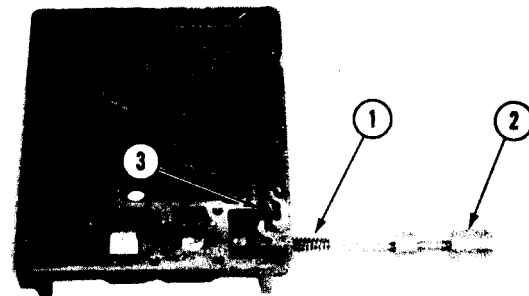

B31741X1

2. Put plate (4) in position on the neutralizer manifold.

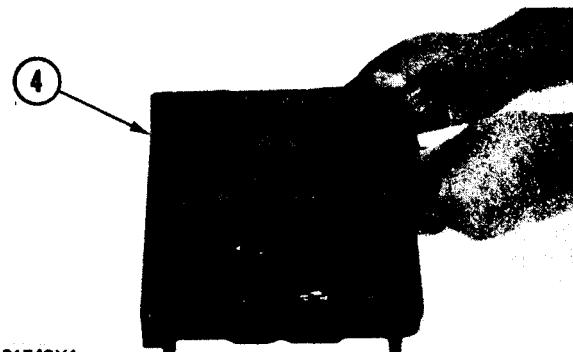

B31742X1

TRANSMISSION HYDRAULIC CONTROL VALVES

3. Install slug (6) in the end of valve spool (7).
Install spring (5) on the end of valve spool (7).

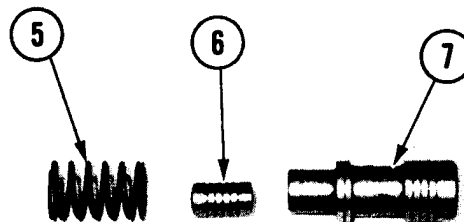

B31743X1

4. Install stop (8) and dowel (10) in the valve body.

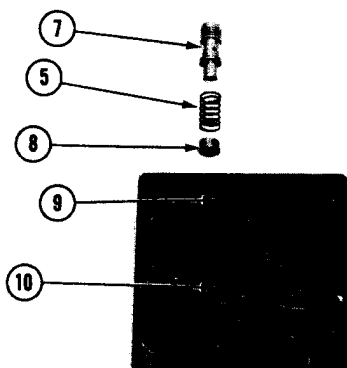

B31744X1

5. Install spring (5) and valve spool (7) as shown.
Install the stop (not showing) and dowel (9) to hold the valve spool, slug and spring in position.

6. Install stop (11) and dowel (12) in the valve body.

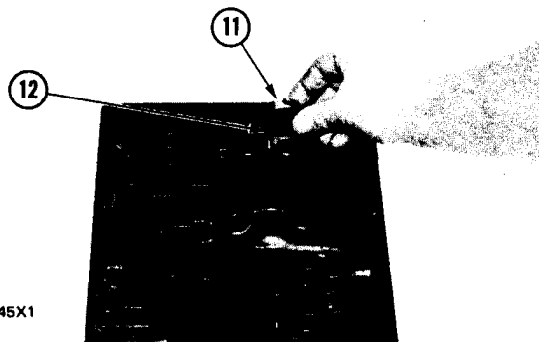

B31745X1

7. Install ball (14), spring (15), retainer (16) and ring (17) in valve spool (13). Install slug (18) in valve spool (13).

8. Install the slug and valve spool (13) in the valve body as shown.

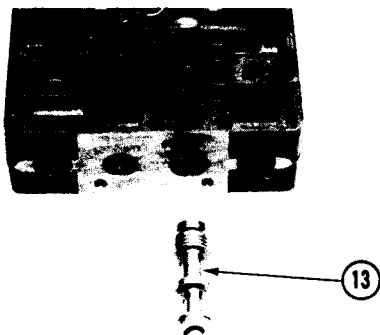

B31747X1

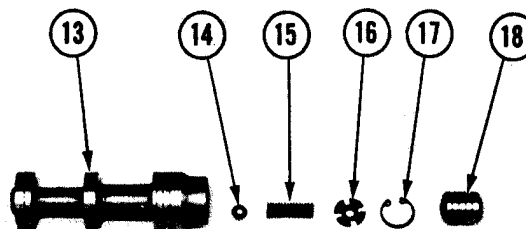

B31746X1

TRANSMISSION HYDRAULIC CONTROL VALVES

- Install spacers (21) of the original thickness, spring (20) and spring (19) in piston (22).

NOTE: Spacers (21) are used to set the primary pressure. See POWER SHIFT TRANSMISSION TESTING AND ADJUSTING, Form No, SENR2152 for the correct procedure to set the primary pressure.

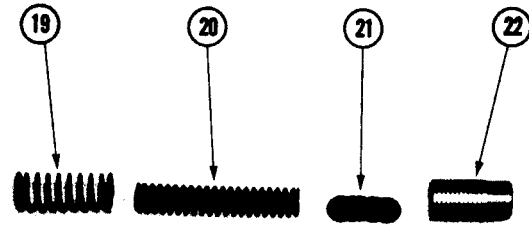

B31748X1

- Install piston (22), the spacers and springs in the valve body as shown.

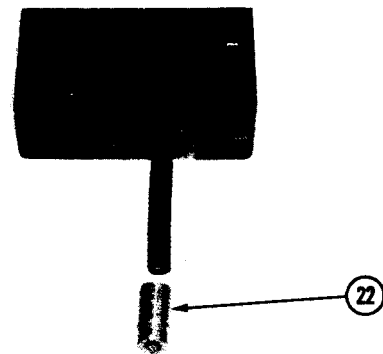

B31749X1

- Install spring (24), spring (25), retainer (26) and ring (27) in valve spool (23).

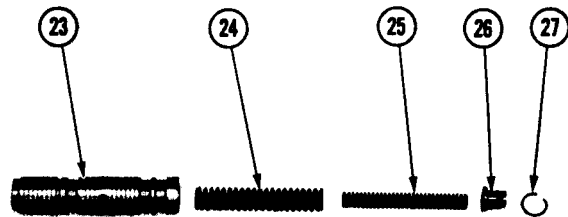

B31750X1

- Install valve spool (23) and spring (28) in the valve body as shown.

- Install the O-ring seals in cover (29) and put clean power train oil on them. Put cover (29) in position and install the bolts to hold it to the valve body. Tighten the bolts to a torque of 30 ± 4 N-m (22 ± 3 lb. ft.).

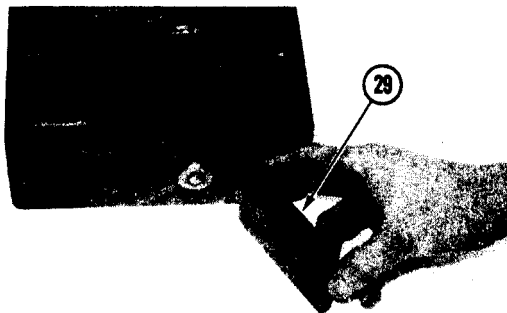

B31752X1

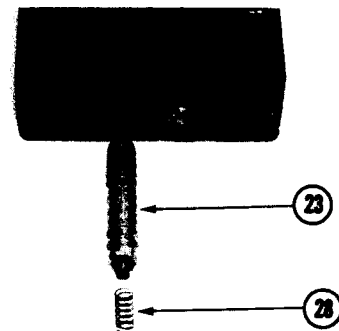

B31751X1

TRANSMISSION HYDRAULIC CONTROL VALVES

14. Install directional control valve spool (30) and speed control valve spool (31) in the valve body.

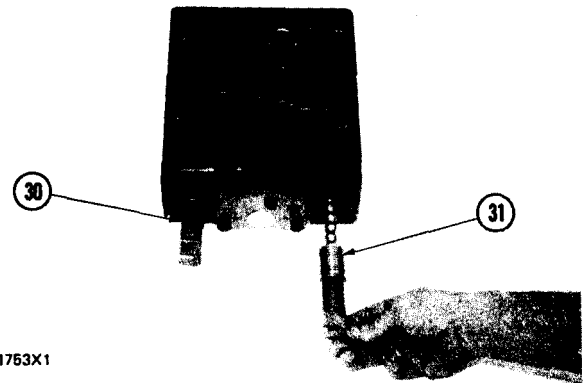

B31753X1

15. Put stops (33) in position in each side of the valve body. Install pins (32) to hold stops (33) in place.

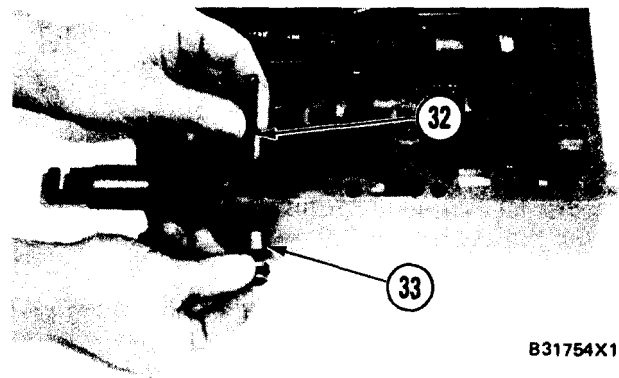

B31754X1

16. Install the O-ring seals around each of the four detent assemblies (34) and put clean power train oil on them. Install detent assemblies (34) in each side of the valve body.

17. Put valve group (35) in position on the plate and neutralizer valve group.

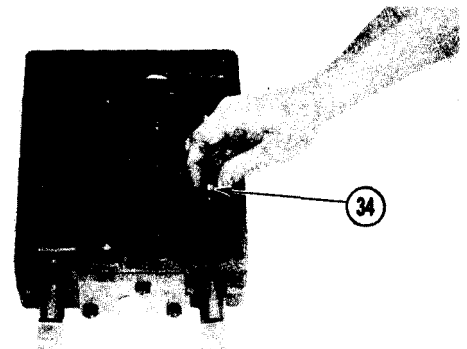

B31755X1

18. Put plate (36) in position on the valve group. Install the bolts to hold the unit together. Tighten the bolts to a torque of 30 ± 4 N-m (22 ± 3 lb. ft.).

end by:

- a) install transmission hydraulic control valves

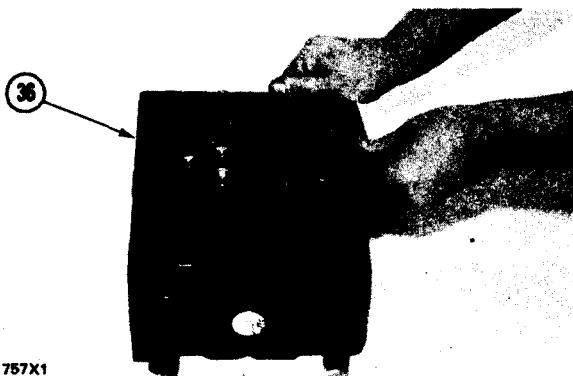

B31757X1

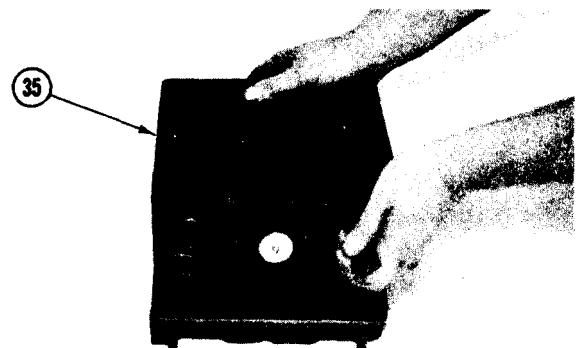

B31756X1

TRANSMISSION

DISASSEMBLE TRANSMISSION 3150-15

Tools Needed	A	B	C	D	E	F	G	H	J	K
5P9736 Link Bracket	3									
1P1863 Pliers		1								
FT833 Clamp			2							
1P1862 Pliers				1						
1P520 Driver Group					1					
5P4758 Pliers						1				
FT947 Clamp							2			
6V2156 Link Bracket								2		
1P1864 Pliers									1	
8B7551 Bearing Puller Attachment										1

start by:

- a) remove transmission hydraulic control valve
- b) separation of torque converter from transmission

1. Fasten tooling (A) and a hoist to housing (4) as shown.
2. Remove the bolts and elbow (1) from case (2) and the transfer gear case. If necessary remove the O-ring seal from the elbow.
3. Remove bolts (3) and make a separation of the transmission from the transfer gear case. The weight of the transmission and case is 340 kg (750 lb.).
4. Remove O-ring seals (5) and (6) from housing (4).
5. Fasten a hoist to housing (4) with two of tooling (A) as shown.
6. Remove bolts (7) and make a separation of the transmission from case (2). The weight of the transmission is 293 kg (650 lb.).
7. Carefully turn the planetary group over so No. 6 (first speed) clutch housing is up.
8. Use tool (B) and remove ring (9) from the shaft.
9. Remove carrier (8).

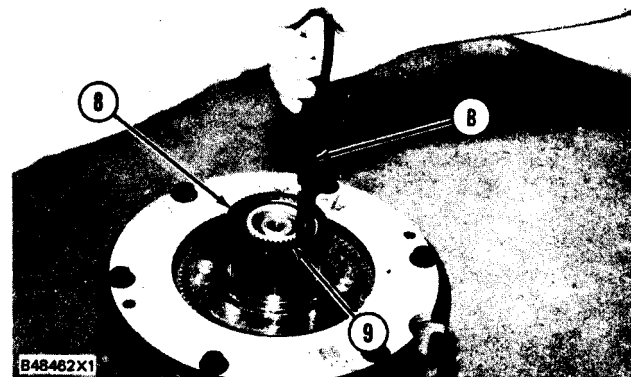
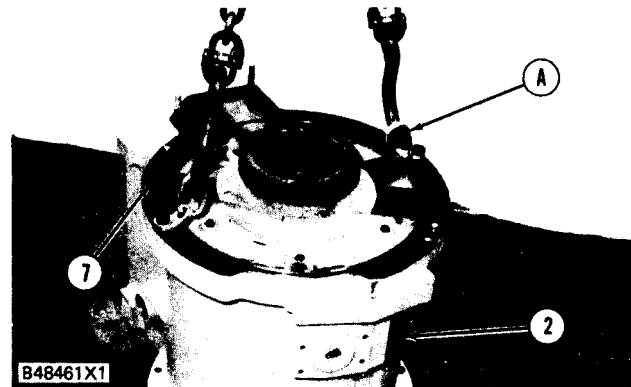
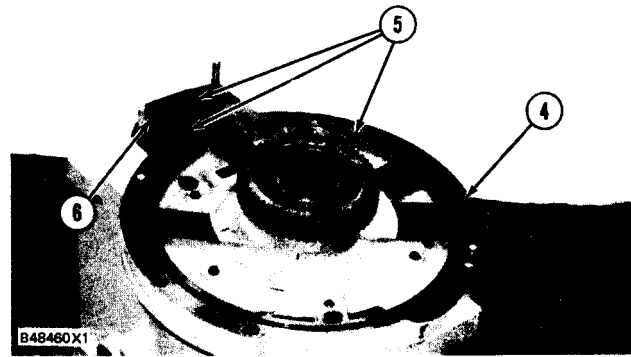
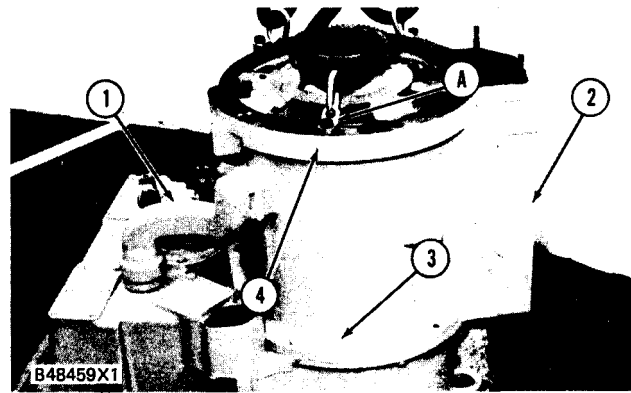

TRANSMISSION

10. Remove ring (10) from the carrier.

CAUTION

Do not remove pins unless inspection reveals need for replacement of bearings. Removal will damage parts.

11. Use a hammer and a punch to push the pins through carrier (8) into shafts (11).

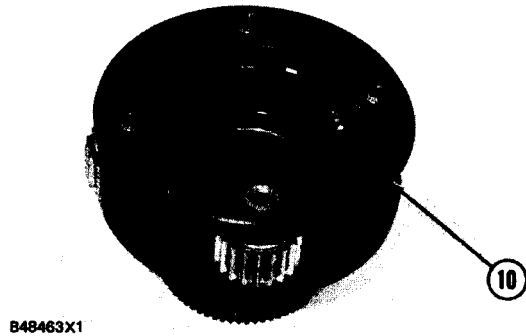

12. Use a hammer and punch and remove shafts (11) from the carrier.

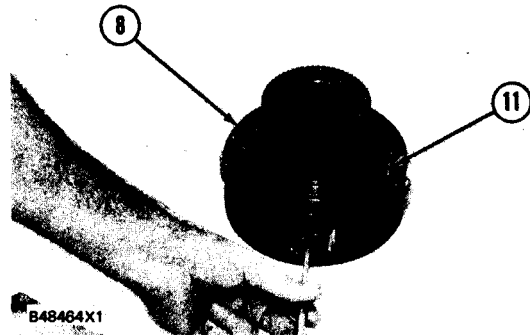

13. Remove washers (12), gears (13), bearings (14) and washers (15) from the carrier. Remove pins (16) from shafts (11).

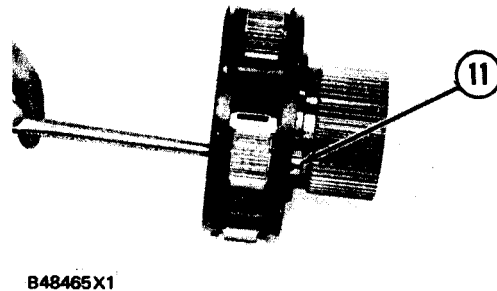

14. Remove bolts (17) that hold No. 6 clutch housing (18) to the planetary group.

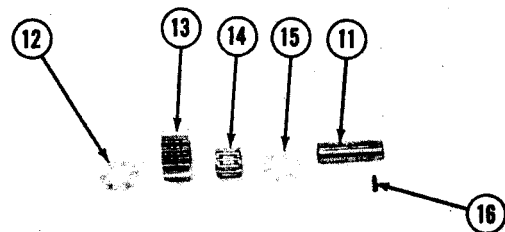
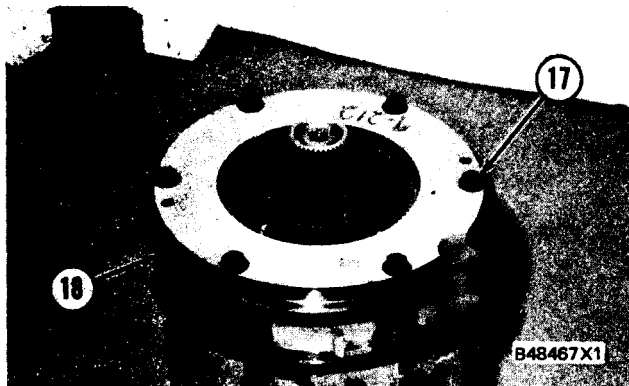

TRANSMISSION

15. Install tooling (C) to hold the piston and plate (19) in the No. 6 clutch housing.

16. Remove No. 6 clutch housing (18).

17. Remove plate (19) from the No. 6 clutch housing.

18. Remove piston (20) and pin (21) from No. 6 clutch housing.

19. Remove rings (22) and (23) from the piston.

20. Remove springs (24), three discs (27) and three plates (26).

21. Remove gear (25).

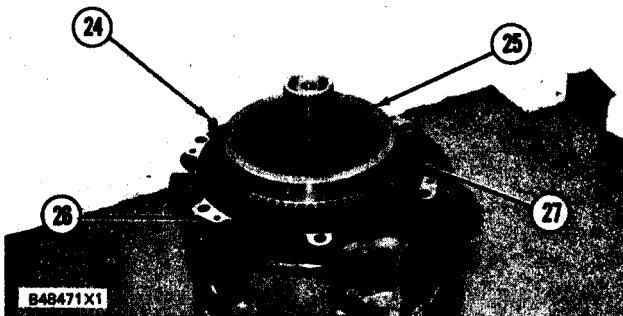
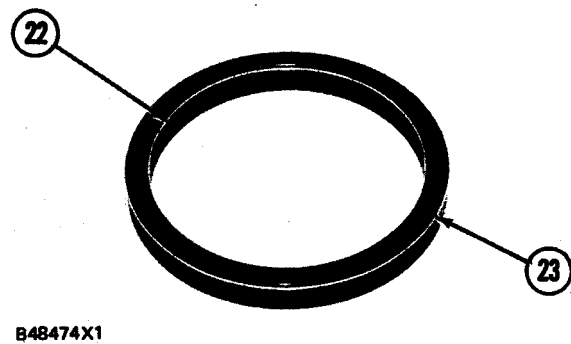
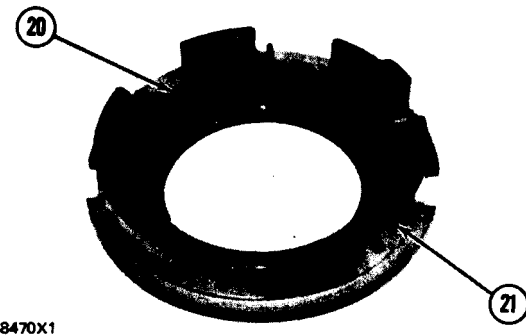
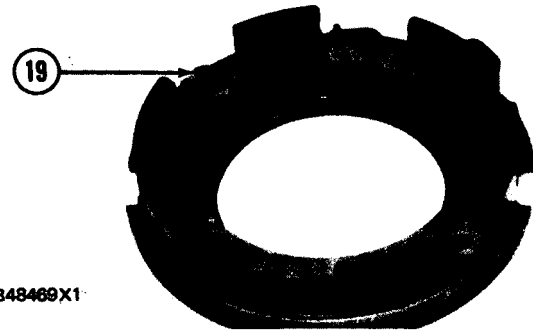
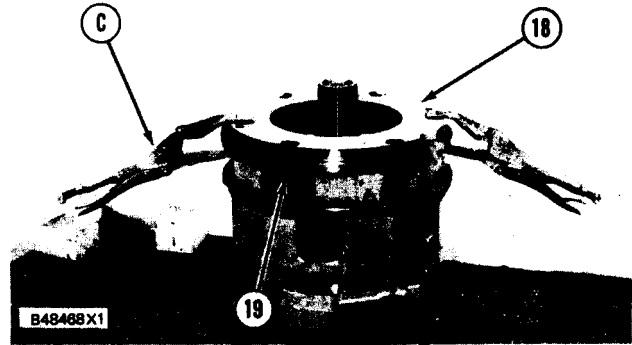

TRANSMISSION

22. Use tool (B) to remove ring (28) from the shaft.

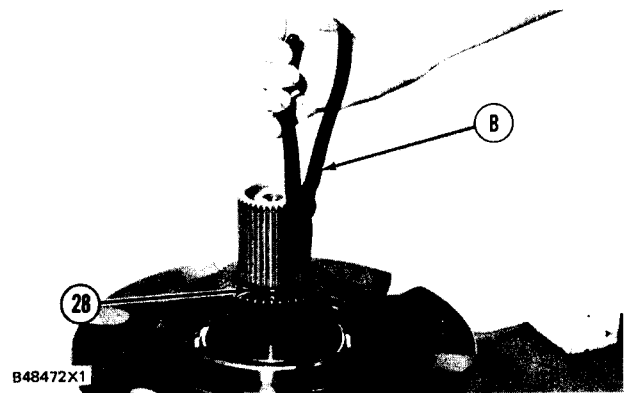

23. Use tool (B) and remove ring (29).

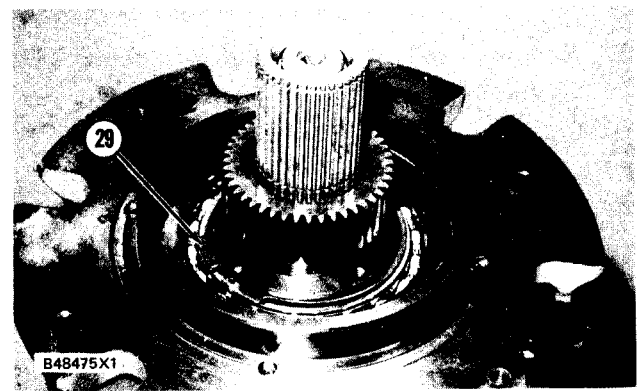

24. Remove bolts (30) that hold the housing to the planetary group.

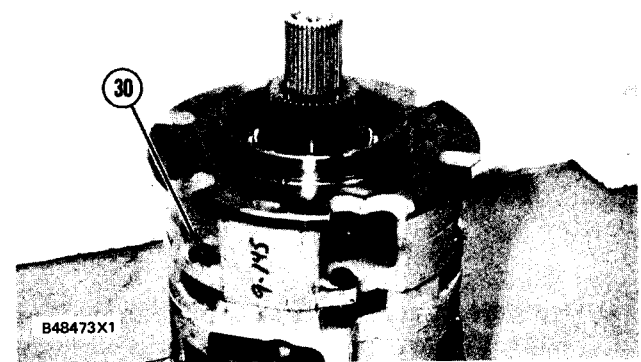

25. Install two of tooling (A) as shown and remove housing (31). The weight of the housing is 29 kg (65 lb.).

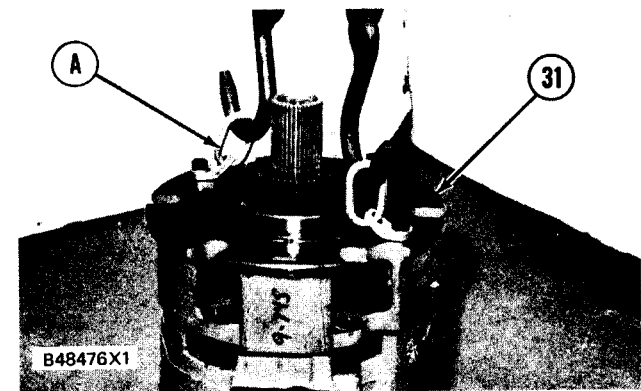

26. Remove ring (32) from the housing with tool (D).

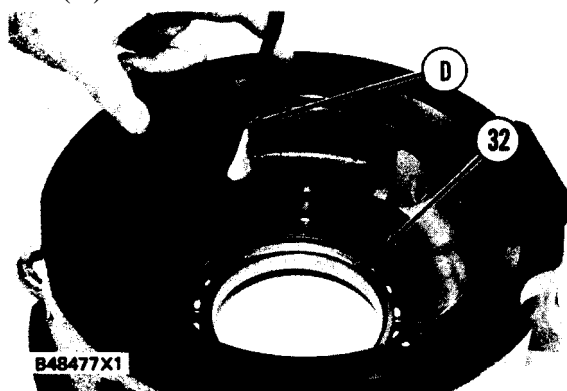

TRANSMISSION

27. Use tooling (E) to remove the bearing from the housing.



28. Remove springs (33).

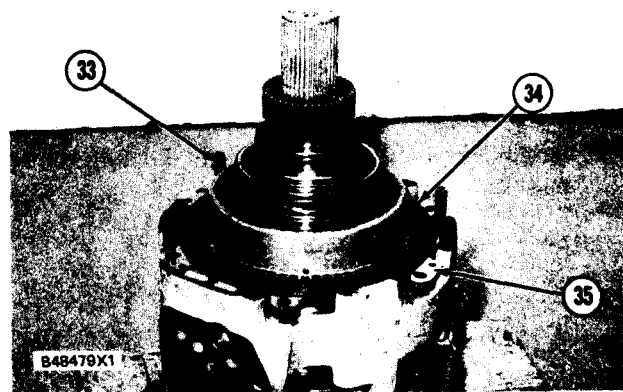

29. Remove two discs (34) and two plates (35) (third speed).

30. Use tool (F) to make a compression of ring (37) and remove housing (36).

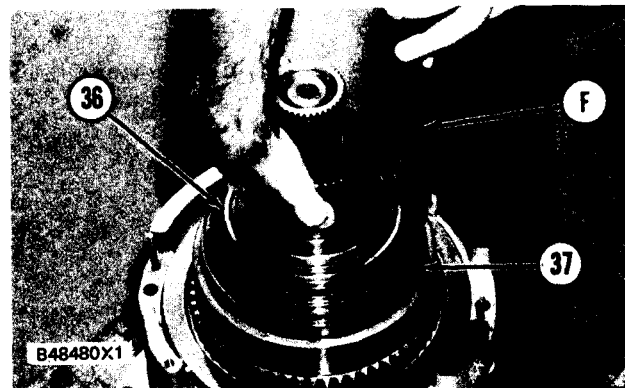

31. Remove ring (37) from the housing.

32. Use steel spacers (38) and a press to push on plate (39) and remove ring (40) from the housing.

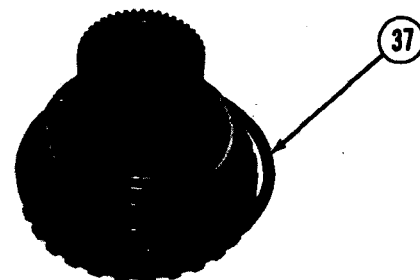
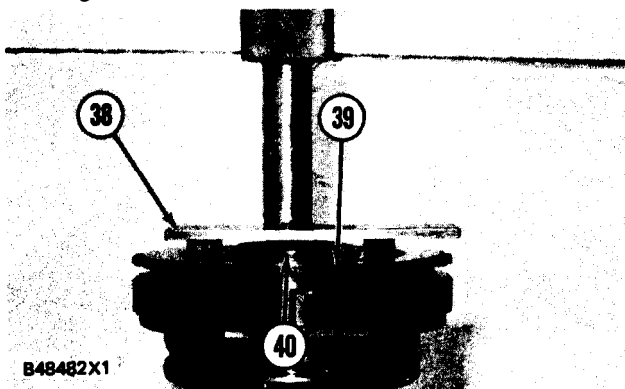

POWER TRAIN

TRANSMISSION

33. Remove plate (39) and springs (42) from the housing.
34. Lift housing (134) from gear assembly (135). For Models 950BNSCE and 950BSCE only, inspect carrier and ring (136); replace if necessary.
35. Remove rings (44) from the housing.
36. Do not remove seal carrier (43) from the housing unless it is worn or damaged. Use a hammer and chisel to break the carrier and remove it. After carrier (43) is removed, remove the pin that holds the carrier in position on the housing.
37. Use tool (D) and remove ring (45).
38. Remove gear (46).
39. Remove four discs (47) and the three plates (second speed).
40. Remove gear (48).

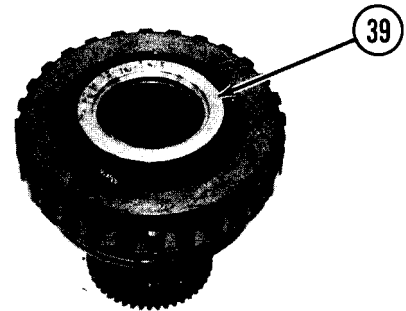

B48483X1

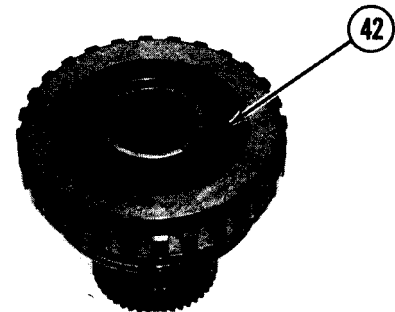

B48484X1

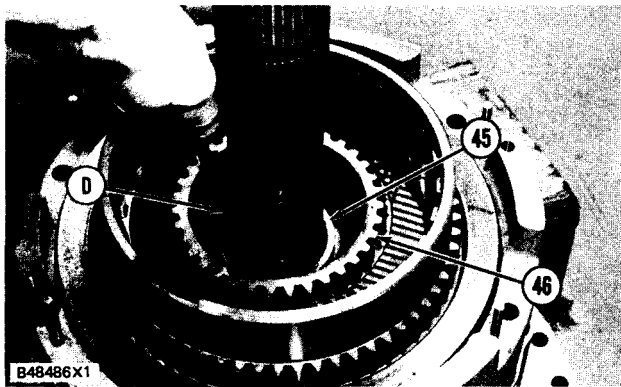

B48486X1

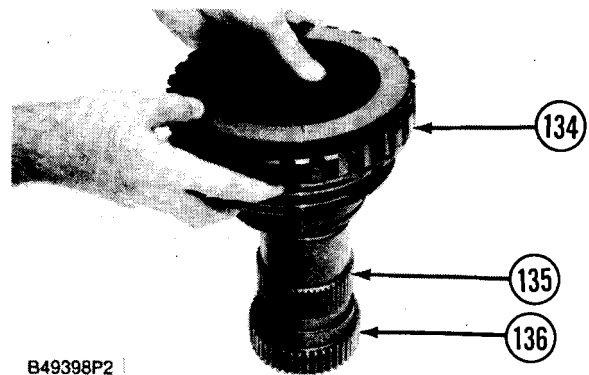

B49398P2

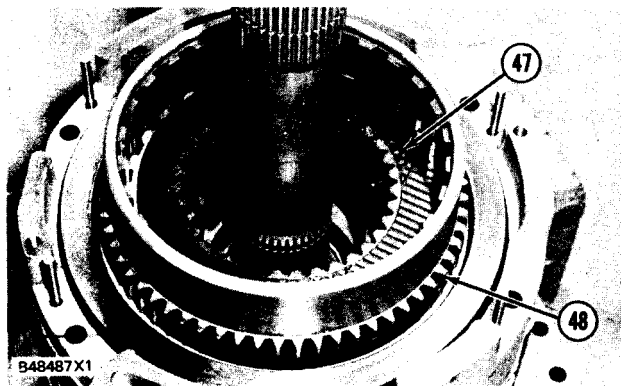

B48487X1

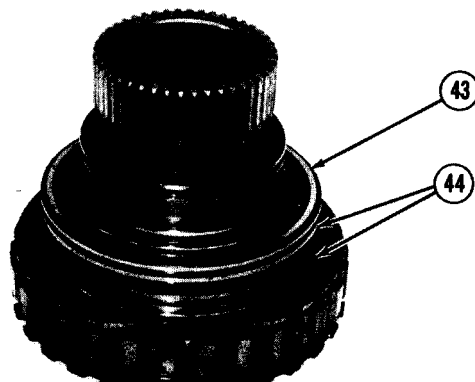

B48485X1

TRANSMISSION

41. Remove ring (49) and plate (50) from the gear.

42. Remove piston (51) from No. 3 and 4 clutch housing.

43. Remove rings (52) and (53) from the piston.

44. Install tooling (G) to hold the plate and the piston in No. 3 and 4 clutch housing (54).

45. Install tooling (H) and a hoist and remove No. 3 and 4 clutch housing (54). The weight of the clutch housing is 32 kg (70 lb.).

46. Remove plate (55) from No. 3 and 4 clutch housing.

47. Remove piston (56) from No. 3 and 4 clutch housing.

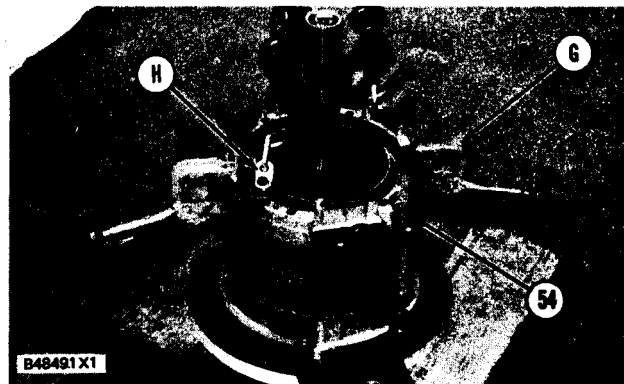
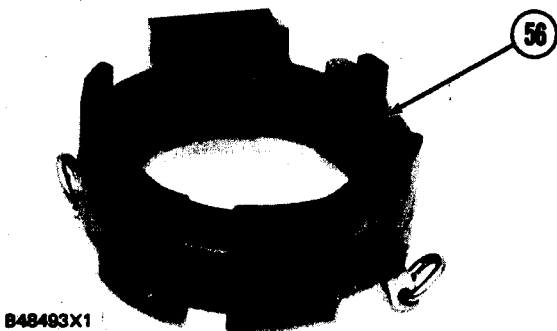
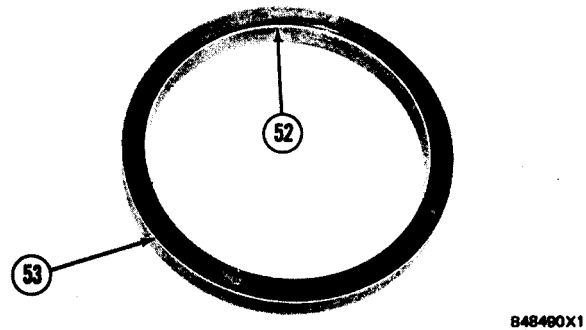
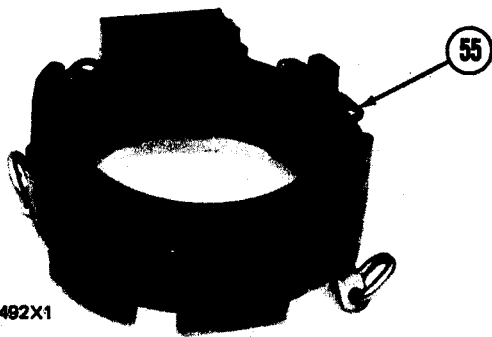
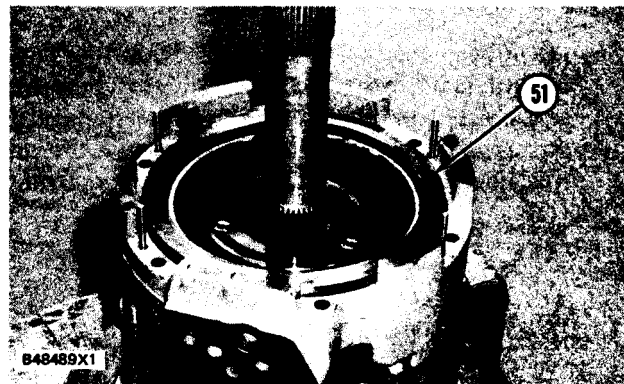
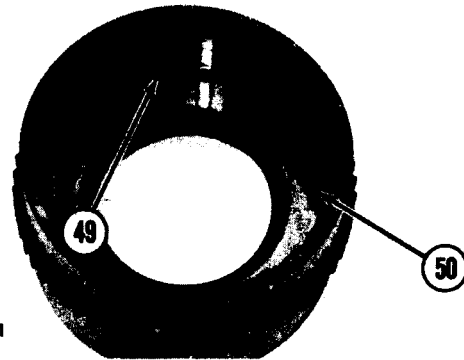

POWER TRAIN

TRANSMISSION

48. Remove rings (57) and (58) from the piston.

49. Remove springs (59) from the rods.

50. Remove three discs (61) and two plates (62).

51. Remove carrier (60) and No. 2 clutch housing.

52. Use 3.175 mm (.125 in.) diameter rods (63) with a point ground on one end to put the ring under compression that holds carrier (60) and gear (64) together.

53. Remove carrier (60) from gear (64).

54. Remove ring (65) from the carrier.

55. Use a hammer and a punch to push the pins through carrier (60) into shafts (66). Remove the shafts.

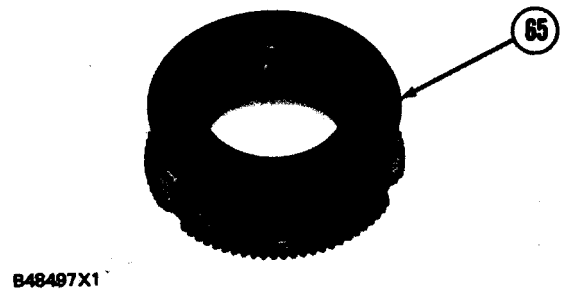
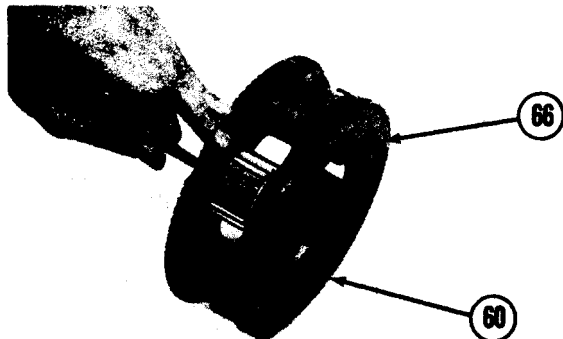
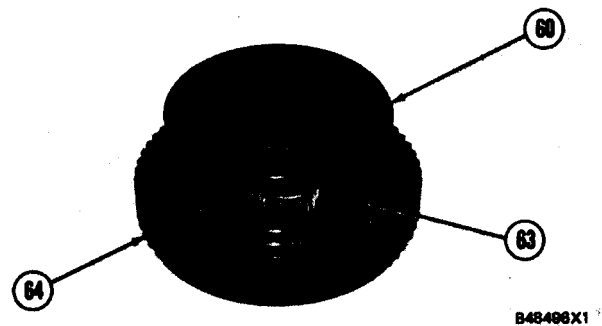
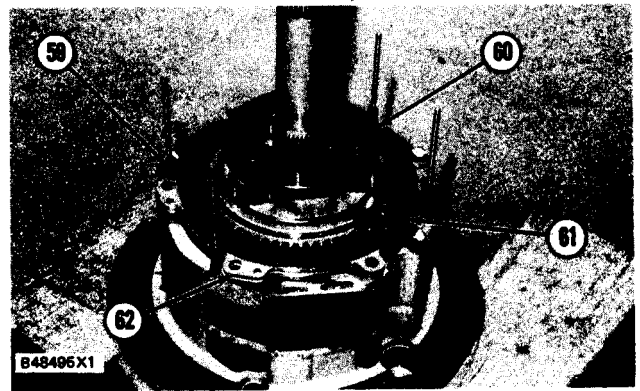
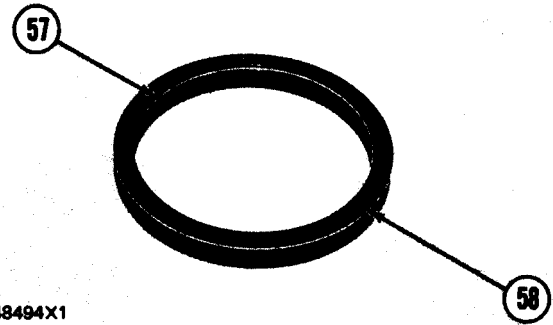

TRANSMISSION

56. Remove washers (67), gears (68), bearings (69) and washers (70) from the carrier. Remove pin (71) from shaft (66).

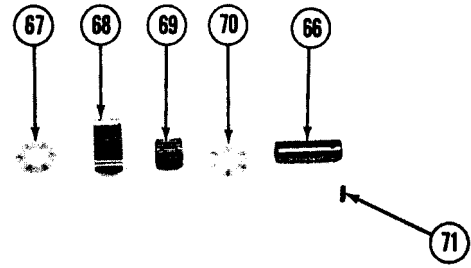

57. Remove ring (72) that holds bearing (73) in the carrier.

B48499X1

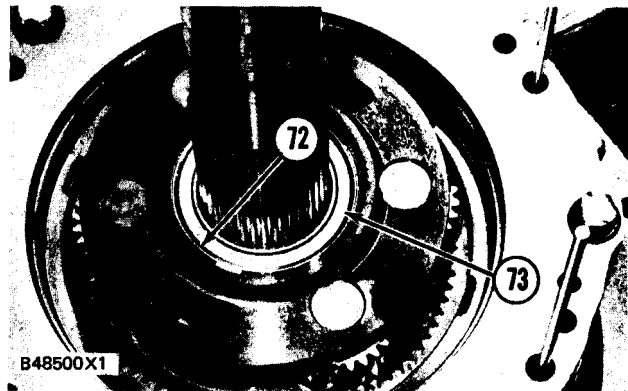

58. Remove shaft (74) and bearing (73) as a unit from the carrier.

B48500X1

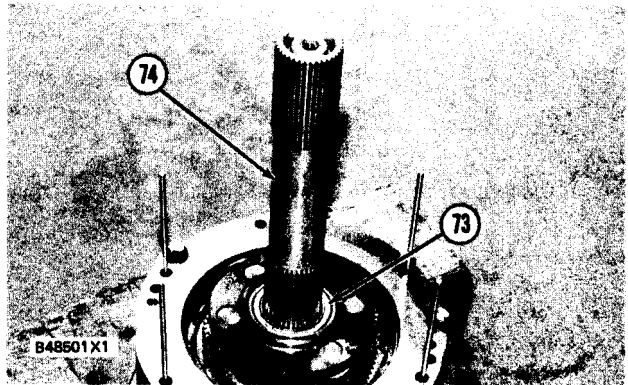

59. Use tool (J) to remove ring (75) and remove gear (76) from the shaft.

60. Use a press and push shaft (74) out of bearing (73) as shown.

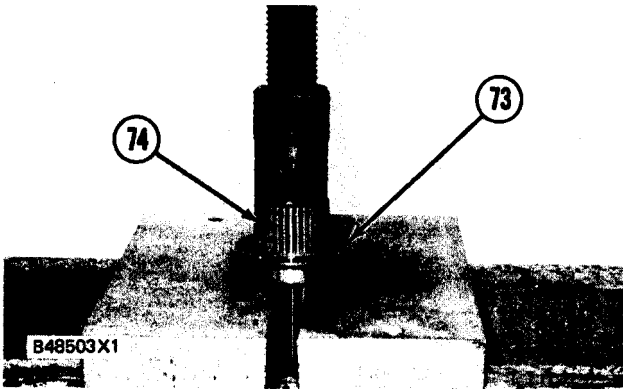

B48503X1



B48502X1

TRANSMISSION

61. If necessary, remove bearing (77) from both ends of shaft (74).

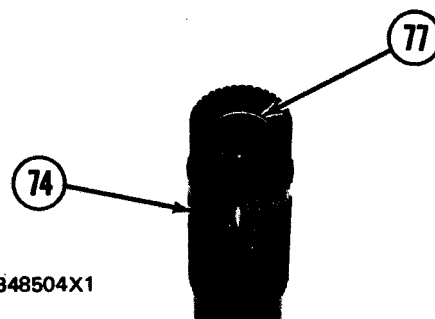

62. Use tooling (C) to hold the plate and piston in No. 2 clutch housing (78).

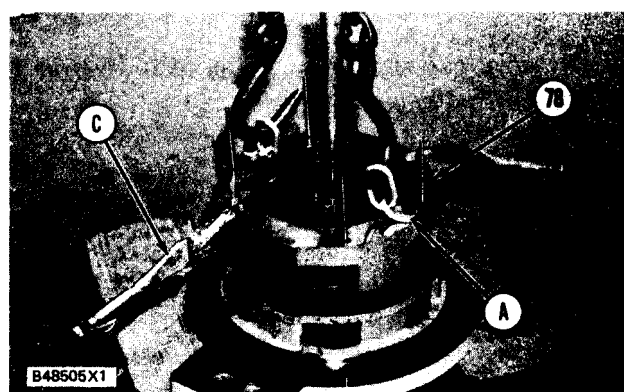

63. Install two of tooling (A) and a hoist to No. 2 clutch housing (78) and remove it. The weight of the housing is 23 kg (50 lb.).

64. Remove plate (79) from the No. 2 clutch housing.

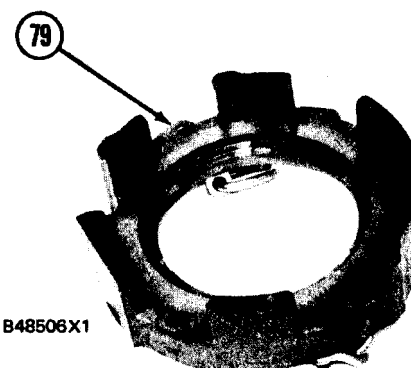

65. Remove piston (80) from the No. 2 clutch housing.

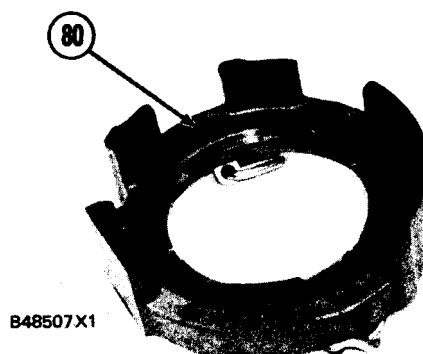

66. Remove rings (81) and (82) from the piston.

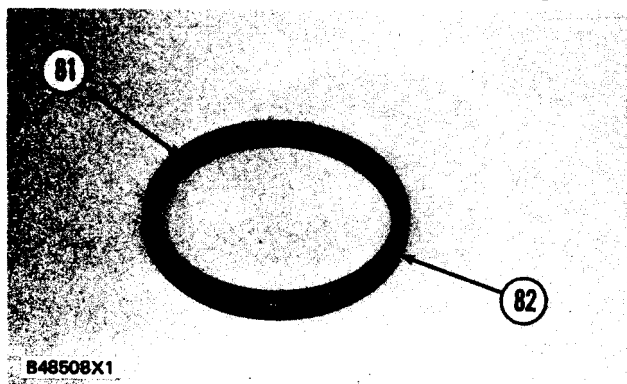

TRANSMISSION

67. Remove springs (85) and rods (83).

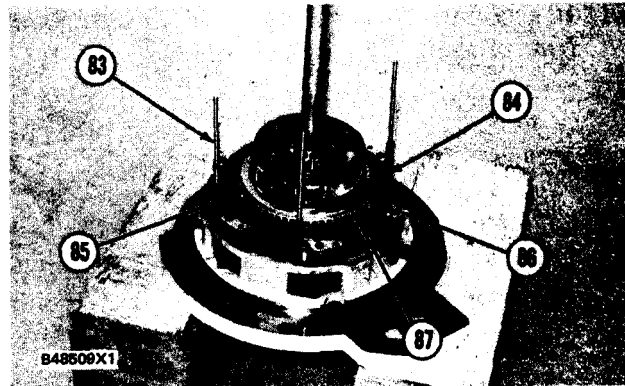

68. Remove four discs (84) and three plates (86) (forward).

69. Use tool (B) to remove ring (88) from the shaft.

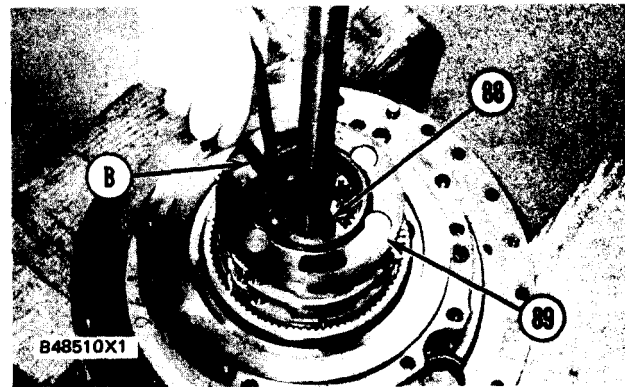

70. Remove carrier (89) and the gear (87) as a unit.

71. Place a small block under carrier (89).

72. Put 2.36 mm (.093 in.) diameter rods (90) with a point ground on one end around carrier (89) and gear (91) as shown. This will compress retaining ring and let gear (91) be lowered from carrier (89).

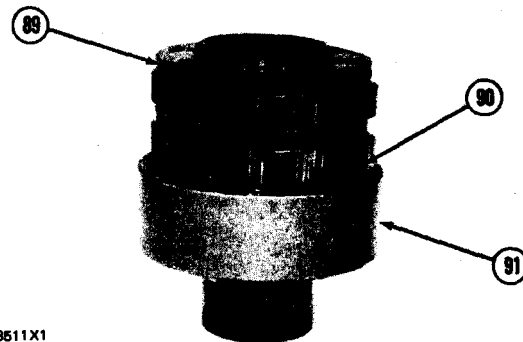

73. Remove retaining ring (92) from the carrier.

74. Use a hammer and punch to push the pins through carrier (89) into shafts (93).

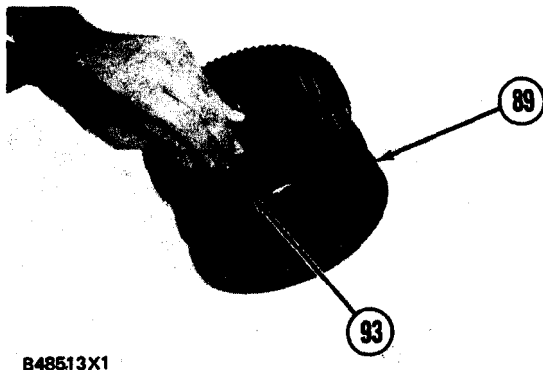
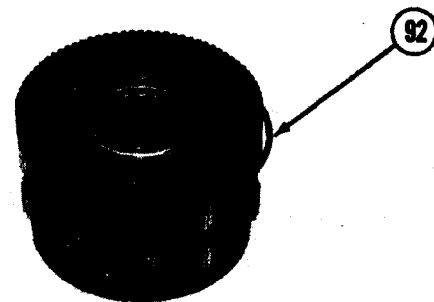

TRANSMISSION

75. Use a hammer and punch and remove shafts (93) from the carrier.

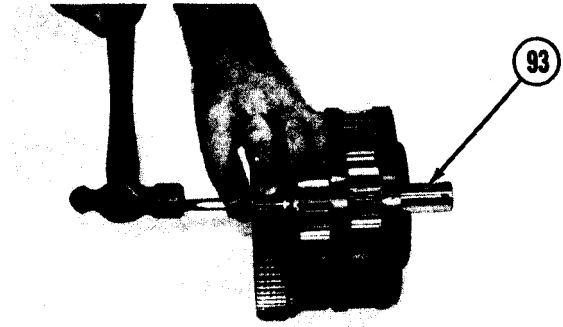

B48514X1

76. Remove washers (99), gears (94), bearings (100), washers (95), washers (101), gears (96), bearings (102) and washers (97) from the carrier.

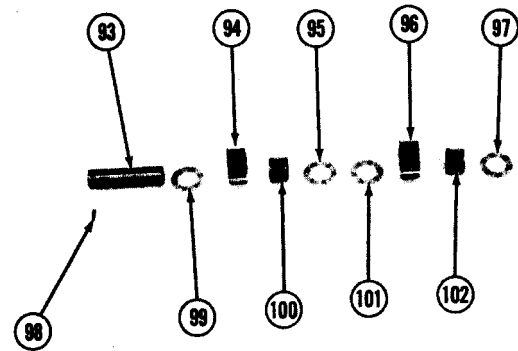

B48515X1

77. Remove pins (98) from shafts (93).

78. Use tool (B) to cause expansion of ring (104). Use tooling (E) to remove bearing (103) and the gear as a unit from the carrier.

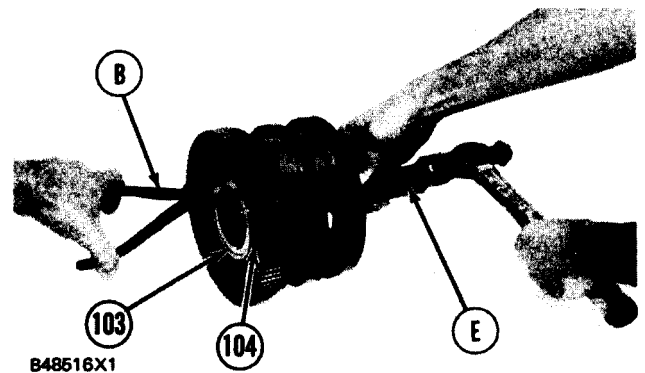

B48516X1

79. Use a press and remove bearing (103) from gear (105).

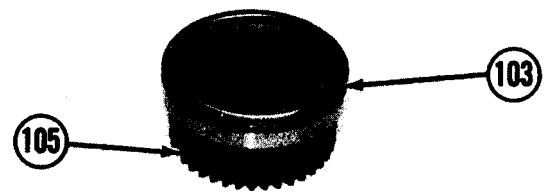

B48517X1

80. Remove ring (104) from the carrier.

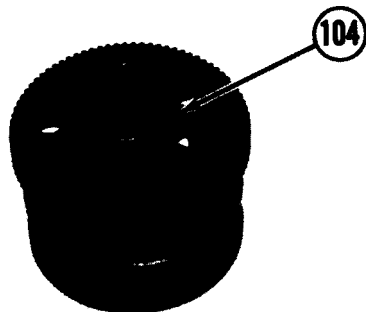

B48518X1

TRANSMISSION

81. Remove plate (106) from the No. 1 clutch housing. For models 950BNSCE and 950BSCE only, remove disk (137) on top of No. 1 carrier.

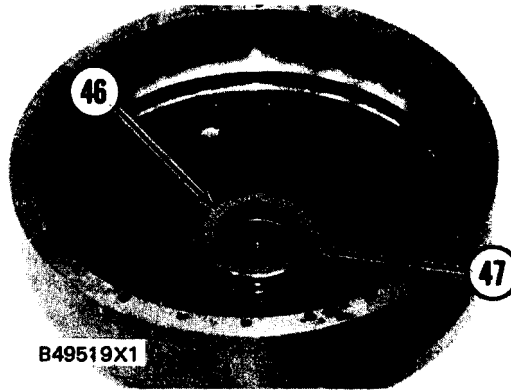

82. Remove four discs (108) and four plates (110) (reverse) from No. 1 clutch housing (109).

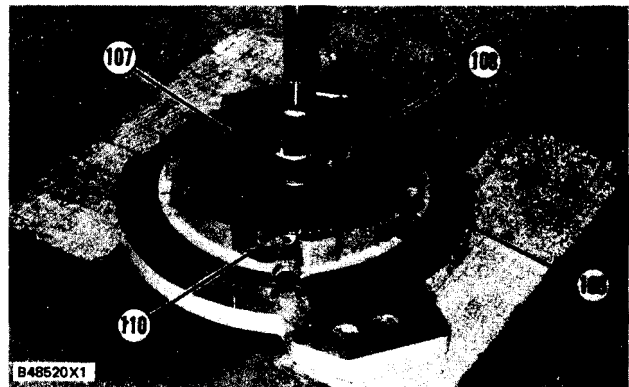

83. Remove carrier (107) from the gear.

84. Remove carrier (111) from carrier (107).

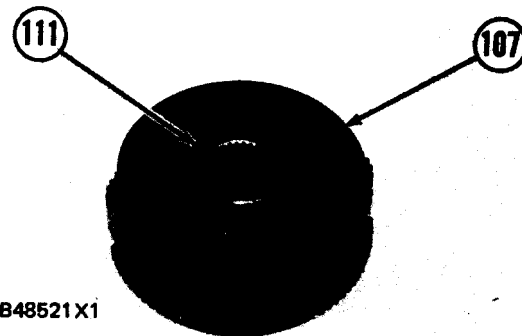

85. Remove ring (112) from the carrier.

86. Remove rings (113) and (114) from the carrier.

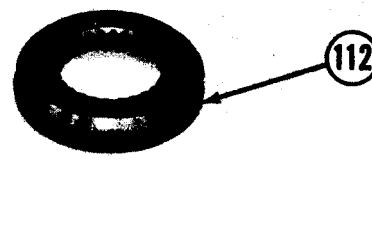
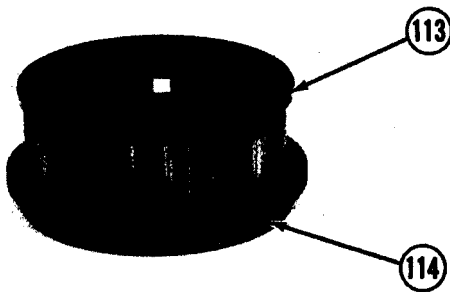

TRANSMISSION

87. Use a hammer and a punch to push the pins through carrier (107) into shaft (115).

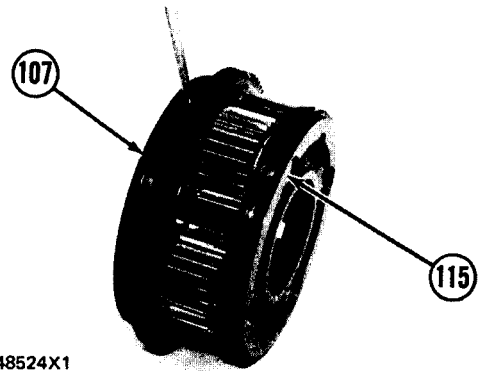

88. Remove washers (116), gears (117), bearings (118) and washers (119) from the carrier.

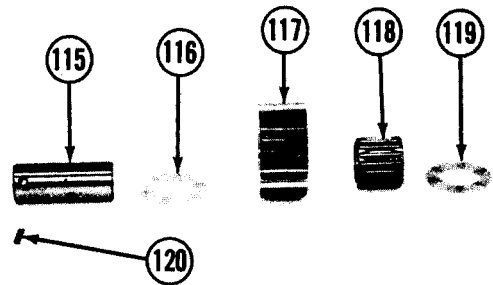

89. Remove pins (120) from shafts (115).

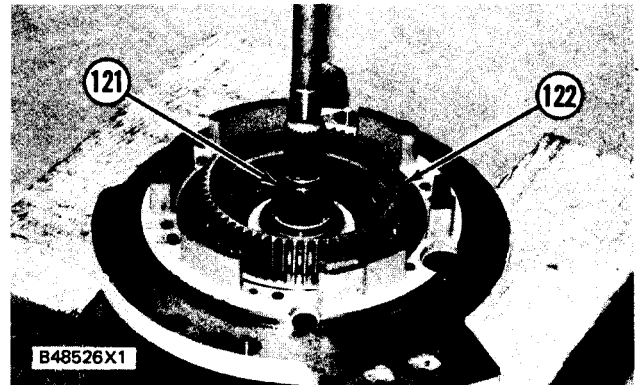

90. Remove gear (121) from the shaft and gear (122) from the No. 1 clutch housing.

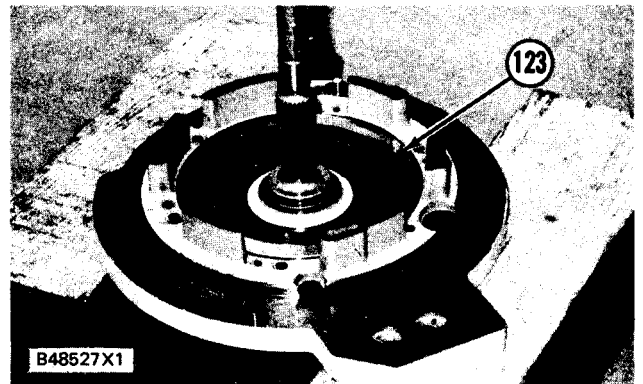

91. Remove piston (123) from the No. 1 clutch housing.

TRANSMISSION

92. Remove rings (124) and (125) from the piston.

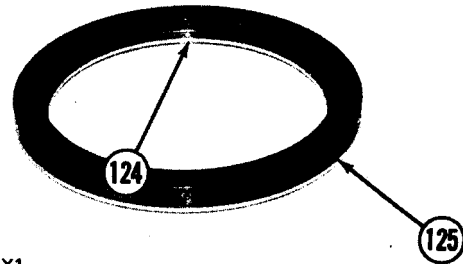

B48528X1

93. Remove ring (127) from shaft (126).

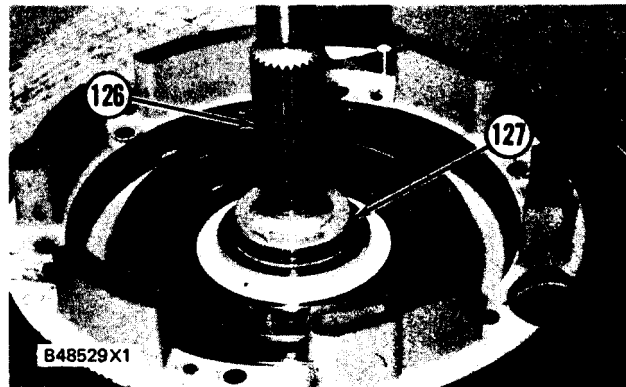

B48529X1

94. Remove bolt (128), retainer (130) and gear (129) from the end of the shaft.

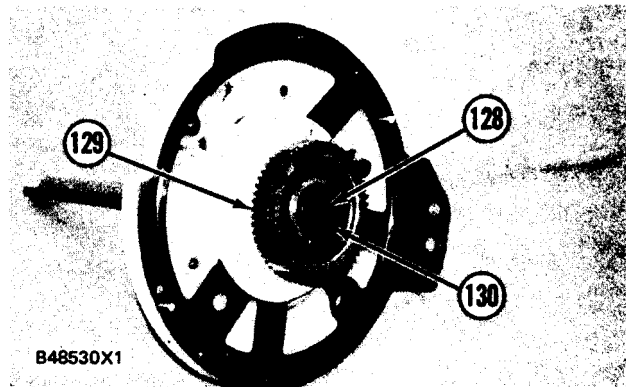

B48530X1

95. Remove ring (131) that holds the bearing and shaft in position in the No. 1 clutch housing.

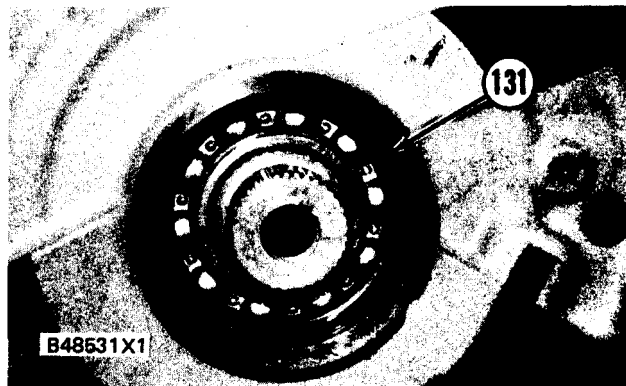

B48531X1

TRANSMISSION

96. Use a soft hammer and remove shaft (126) and the bearing from the No. 1 clutch housing.

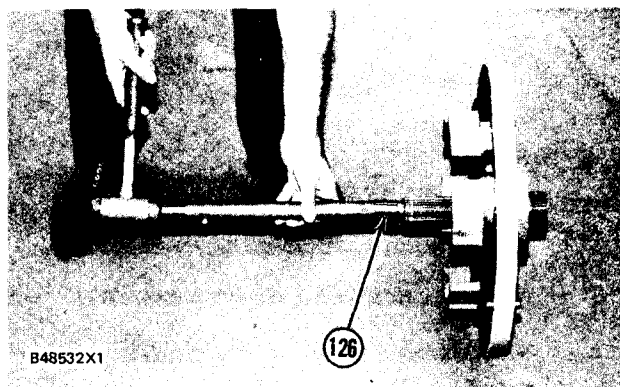

97. Remove seals (127) from the shaft.

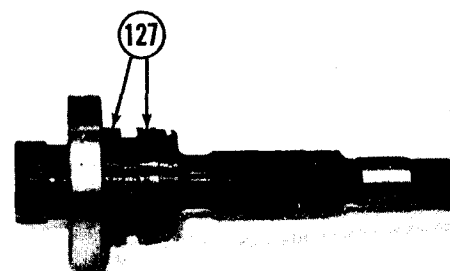

98. Use a press and tool (K) to remove bearing (132) from the shaft.

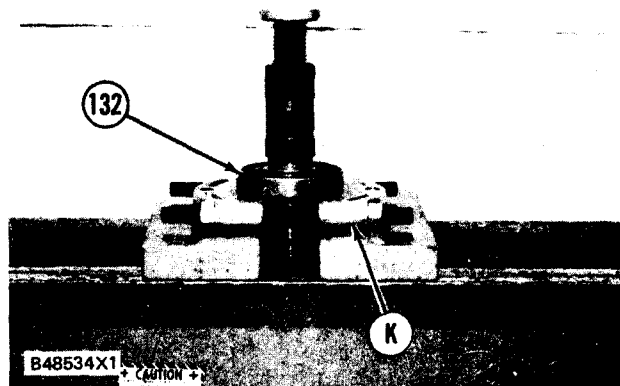

99. Remove dowels (133) from the No. 1 clutch housing.

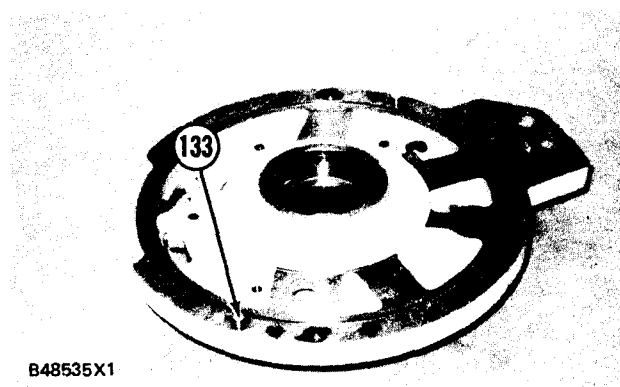

TRANSMISSION

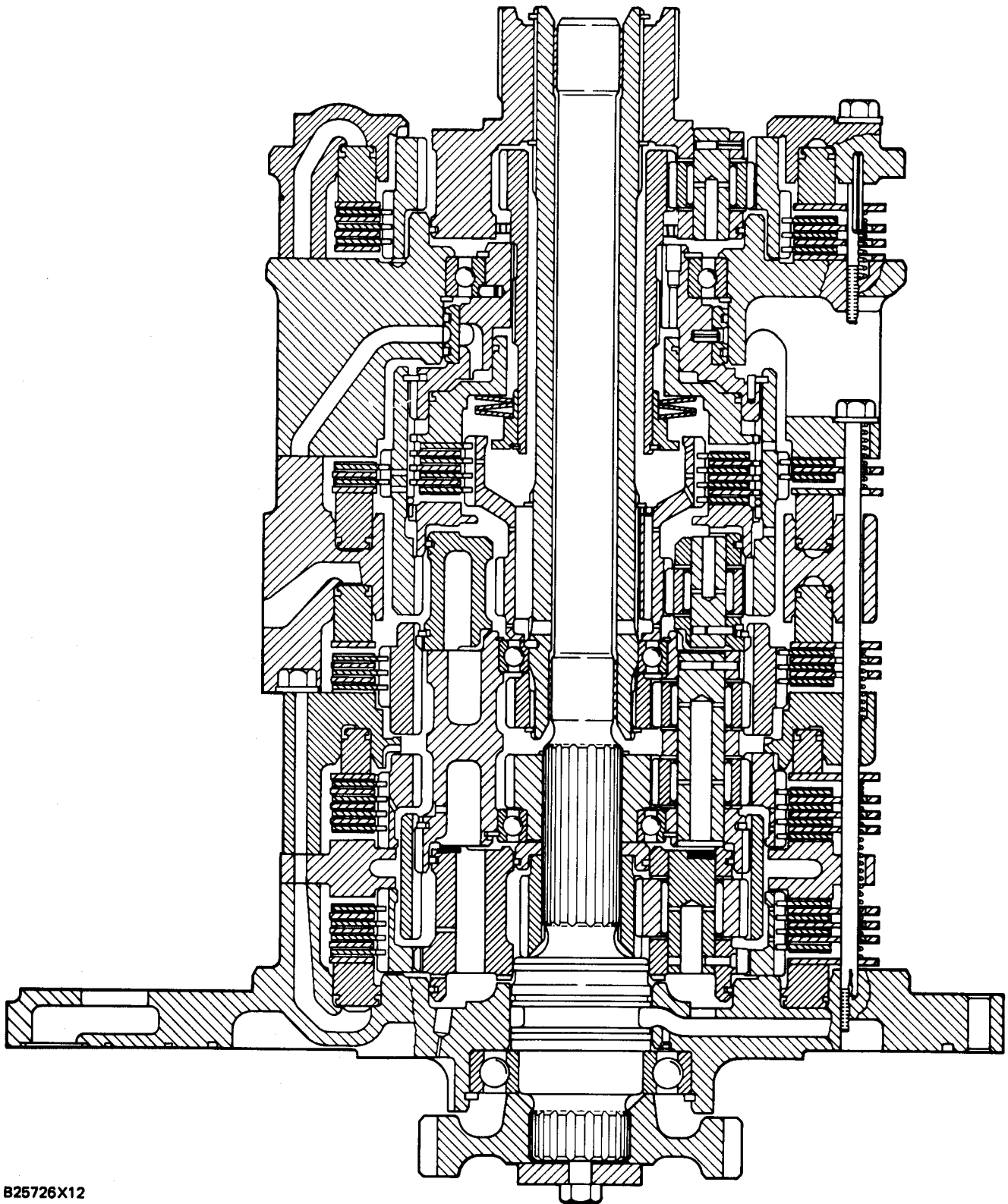

B25726X12

TRANSMISSION

ASSEMBLE TRANSMISSION

3150-16

Tools Needed	A	B	C	D	E	F	G	H	J	K
1P1863 Pliers		1								
5P9736 Link Bracket		3								
FT833 Clamp			2							
1P510 Driver Group				1						
1P1684 Pliers					1					
6V2156 Link Bracket						2				
FT947 Clamp							2			
5P4758 Pliers								1		
1P520 Driver Group									1	
FT834 Clutch Testing Nozzle										1

NOTE: Inspect all parts for wear or damage and make replacements if needed. Put clean power train oil on the parts at assembly.

1. Install two dowels (2) in each side of No. 1 clutch housing (1). The dowels must be installed $10.5 \pm .5$ mm ($.41 \pm .020$ in.) above the outside surface.
2. Heat bearing (3) to a maximum temperature of 135° C (275° F) and install it on shaft (4) as shown.
3. Install seals (5) and (6) on the shaft.
4. Carefully install shaft (4) in the No. 1 clutch housing.

CAUTION

Make sure the seals are not damaged when the shaft is installed in the bore of the No. 1 clutch housing.

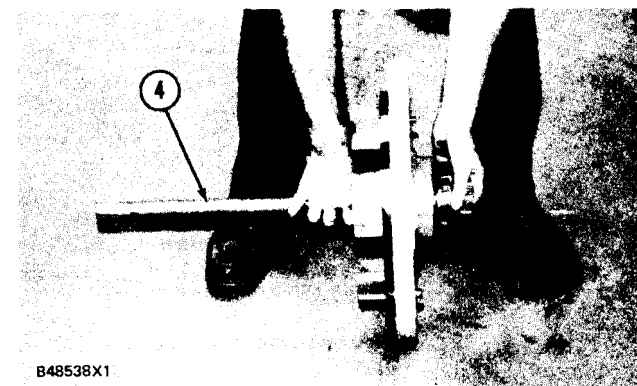
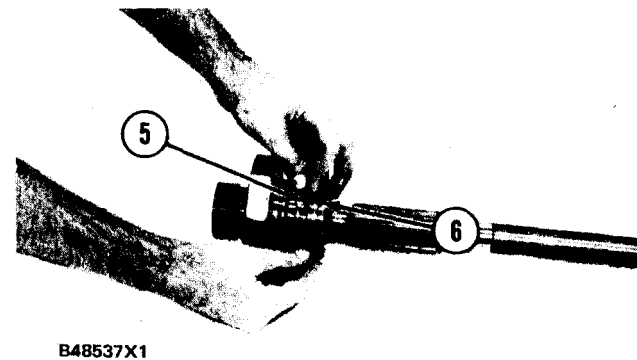
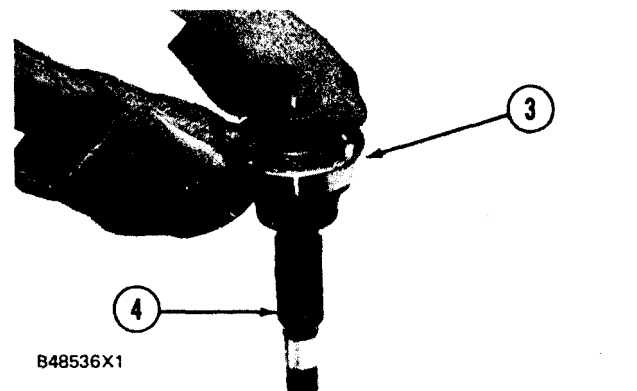
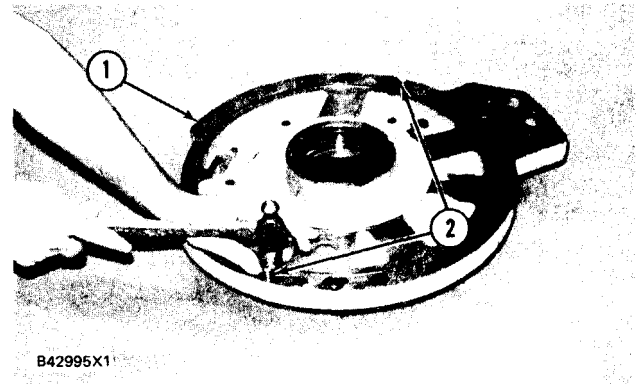

TRANSMISSION

5. Install ring (7) in the No. 1 clutch housing to hold the shaft and bearing in place.

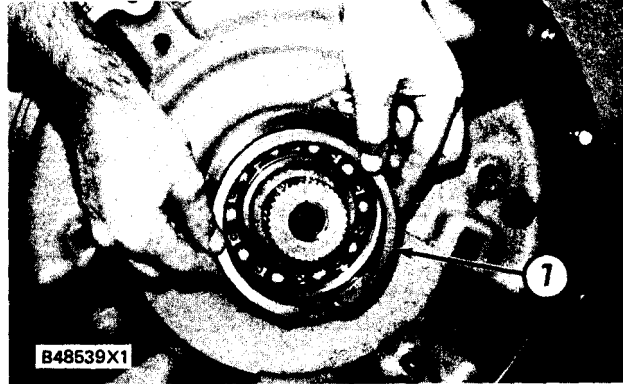

6. Install gear (8) on the end of the shaft as shown.

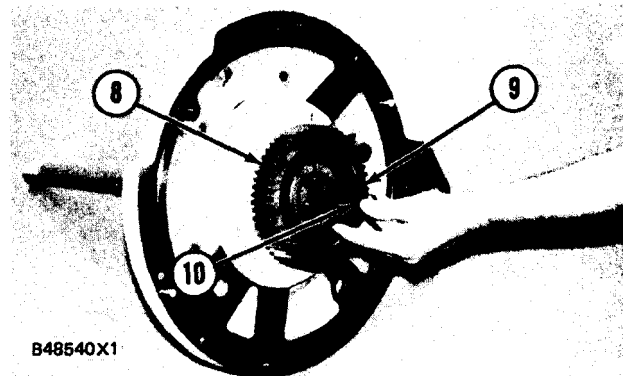

7. Install retainer (9) and bolt (10). Tighten the bolt to a torque of $110 \pm 10 \text{ N}\cdot\text{m}$ ($80 \pm 7 \text{ lb}\cdot\text{ft.}$).

8. Install ring (11) on shaft (4).

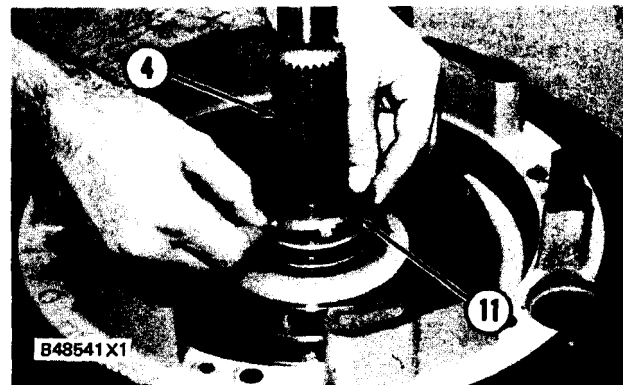

9. Install rings (12) and (14) on piston (13). Make sure the lips of the rings are as shown on the piston.

10. Install piston (13) in the No. 1 clutch housing. Make sure that the lips of the seals are down.

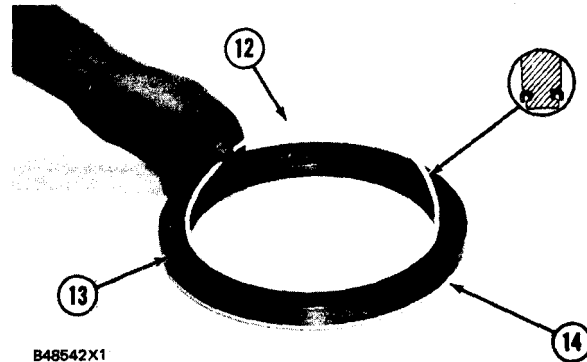
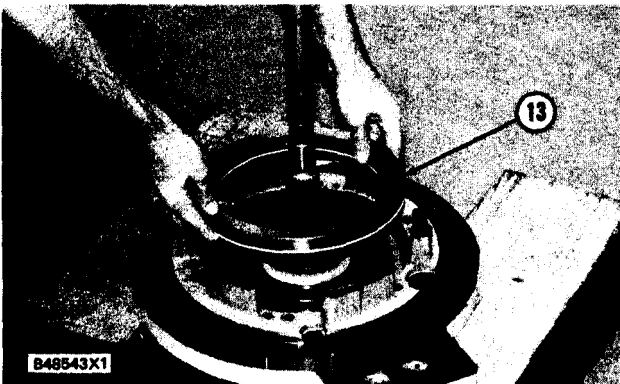

TRANSMISSION

11. Install gear (15) in the No. 1 clutch housing.

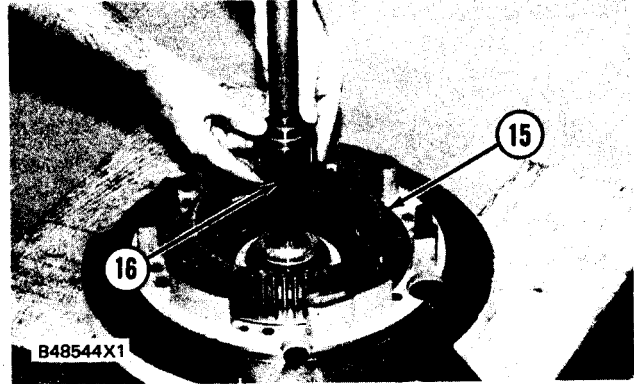

12. Install gear (16) on the shaft.

13. Install bearing (20) in gear (19).

14. Install washers (18), the gears and bearings and washers (21) in the carrier.

15. Install shafts (17) that hold the washers, gears and bearings in carrier (23).

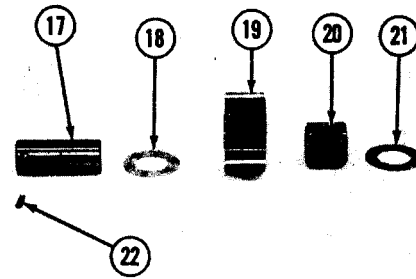

NOTE: If pins (22) are damaged, a replacement will be necessary.

16. Use a hammer and a punch to install pins (22) that hold the shafts in the carrier. Make sure the pins are installed even with the counterbore in the carrier.

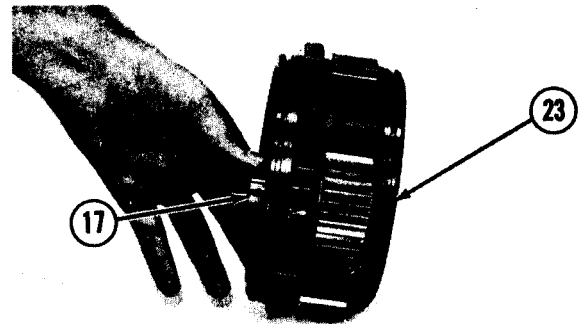

17. Install ring (24) on carrier (23).

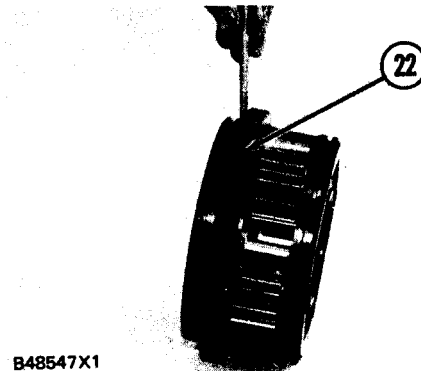
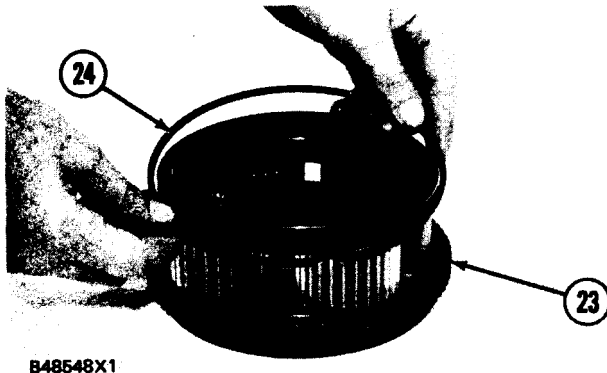

TRANSMISSION

18. Install ring (25) on carrier (26).

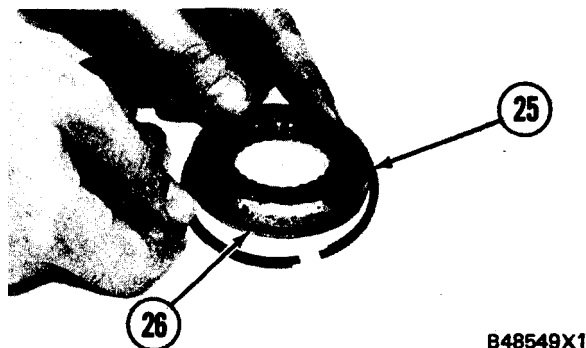

19. Install carrier (26) in carrier (23).

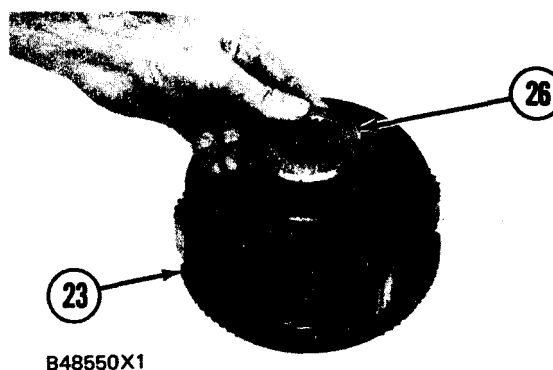

20. Make an alignment of the gear on the shaft and carrier and carrier (23) with gear (15). Install carrier (23) in the No. 1 clutch housing.

21. Install date (27) in the No. 1 clutch housing so the small hole in the plate is in alignment with small hole (29) in the housing.

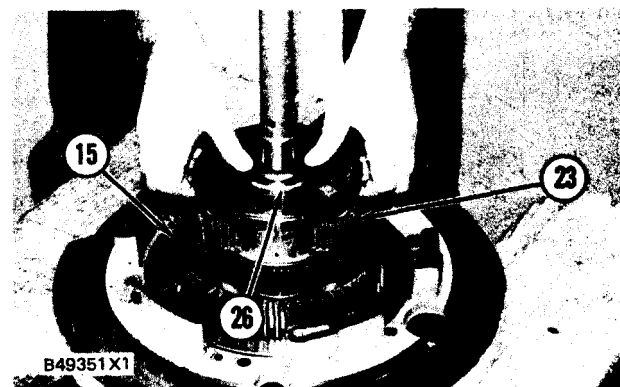

22. Install four discs (28) and three plates (30) (reverse) in the No. 1 clutch housing. Start and stop with a disc.

23. Put plate (31) in position on the No. 1 clutch housing as shown. For models 950BNSCE and 950BSCE only, install disk (138) on No. 1 carrier with smaller diameter up.

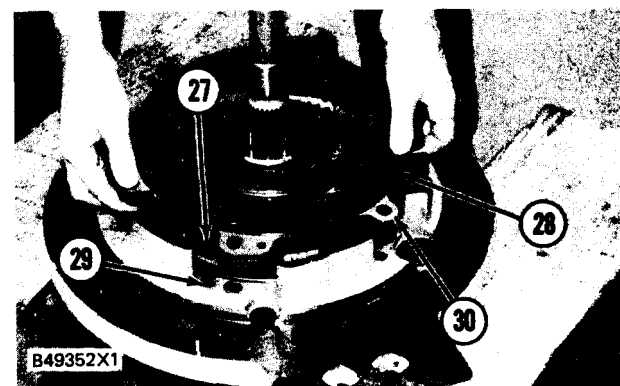
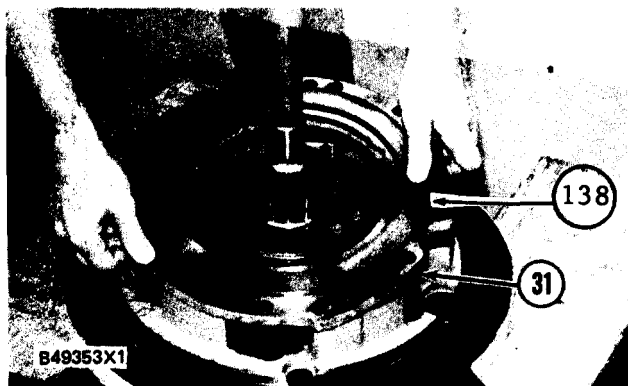

TRANSMISSION

24. Heat bearing (32) to a maximum temperature of 135° C (275° F) and install it on gear (33). Make sure the bearing is installed so the groove is toward the top.
25. Install ring (34) in the groove of carrier (35) as shown.
26. Use tool (A) to cause expansion of the ring. Use tooling (J) and a press to install the bearing and gear in carrier (35). The ring must be installed in the groove of the bearing.
27. Install bearings (39) in gears (38) and bearings (43) in gears (42).
28. Install washers (37), gears (38) and washers (40) in the upper carrier.
29. Install washers (41), gears (42) and washers (44) in the lower carrier.
30. Install shafts (36) in the carrier that hold the washers, gears and bearing in place.
31. Use a hammer and punch to install pins (45) that hold the shafts in the carrier.

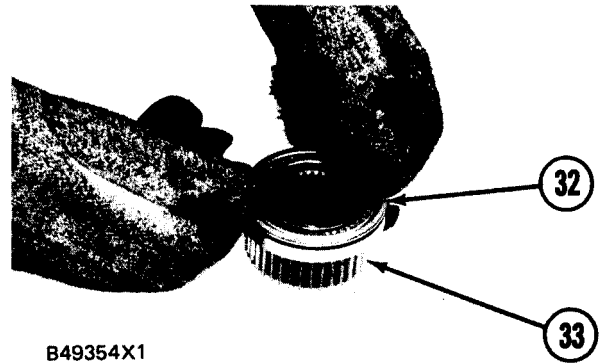

B49354X1

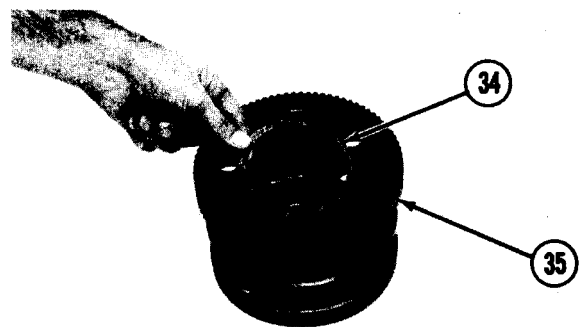

B49355X1

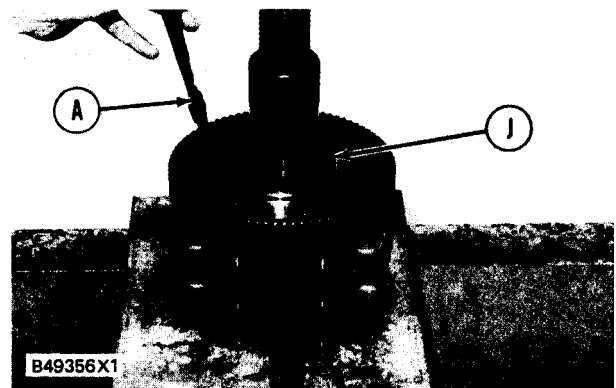

B49356X1

NOTE: If pins (45) are damaged, a replacement will be necessary.

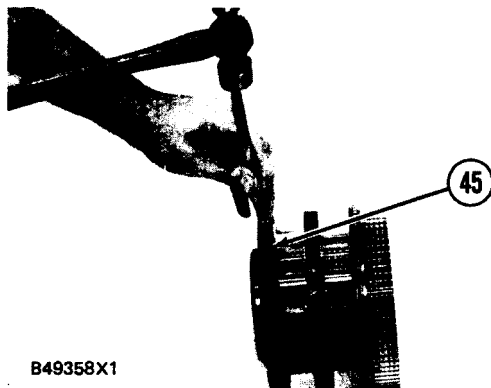

B49358X1

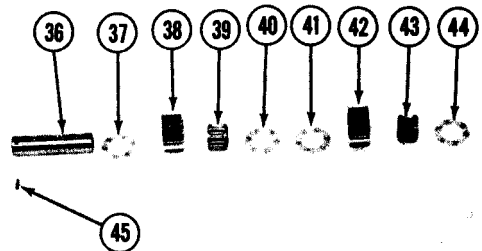

B49357X1

TRANSMISSION

32. Install retaining ring (46) in the groove of carrier (35).

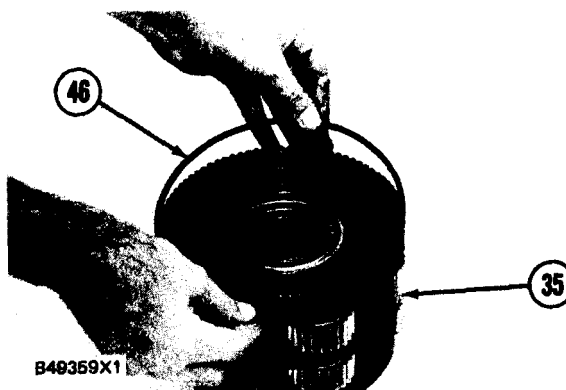

33. Compress retaining ring (46) and install carrier (35) in gear (47) until the ring fits into the groove in the gear.

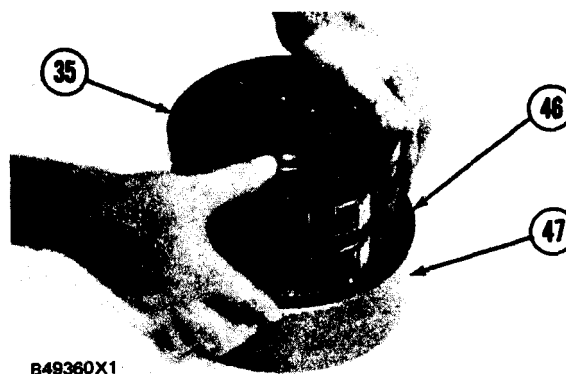

34. Install carrier (35) and gear (47) on the carrier in the No. 1 clutch housing. Make sure the gear teeth are correctly engaged.

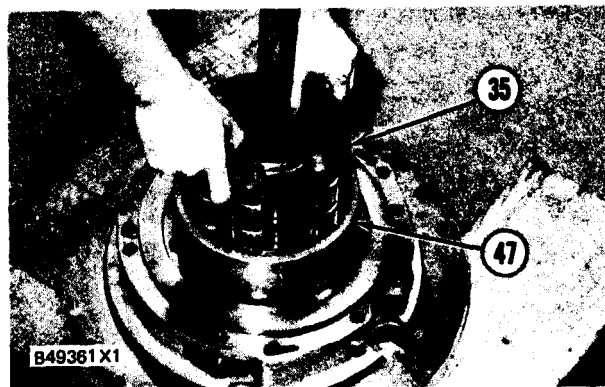

35. Use tool (A) to install ring (48) on the shaft that holds the carrier in place.

36. Install springs (50) on rods (49) and install them as shown.

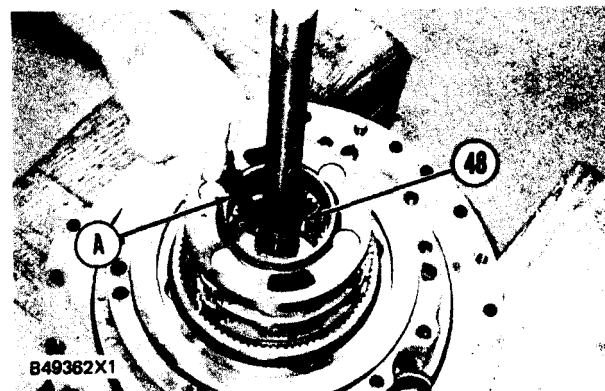
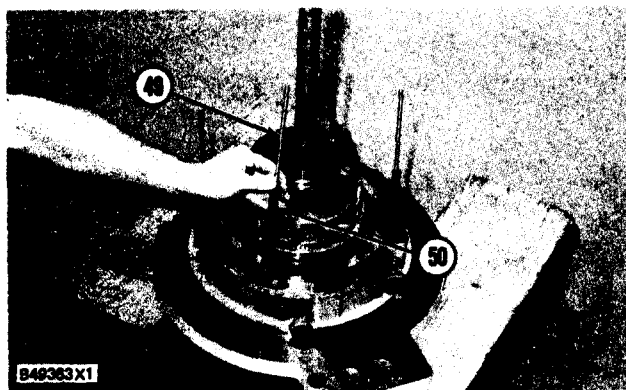

TRANSMISSION

37. Install gear (51) on carrier (35). Make sure the gear teeth are correctly engaged.

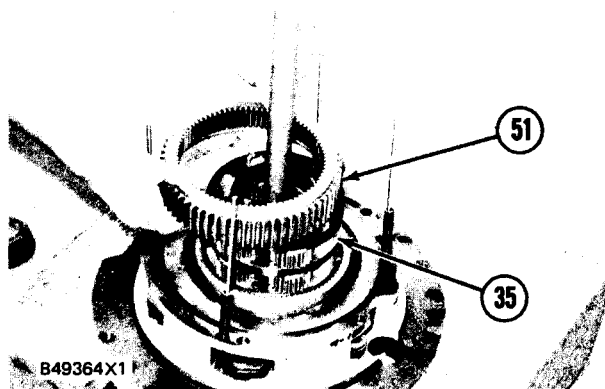

38. Install four discs (52) and three plates (53) (forward) on plate (31). Start and stop with a disc.

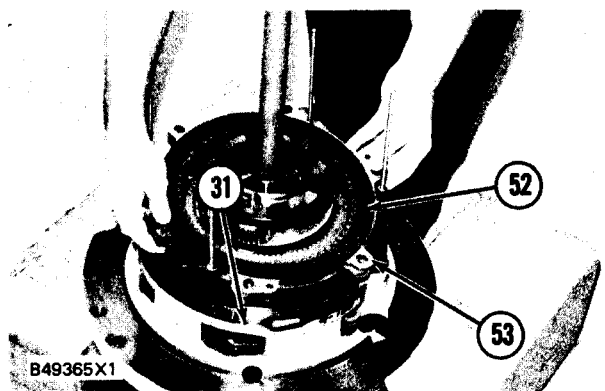

39. Install rings (54) and (55) on piston (56) as shown. Make sure the lips of the rings are as shown on the piston.

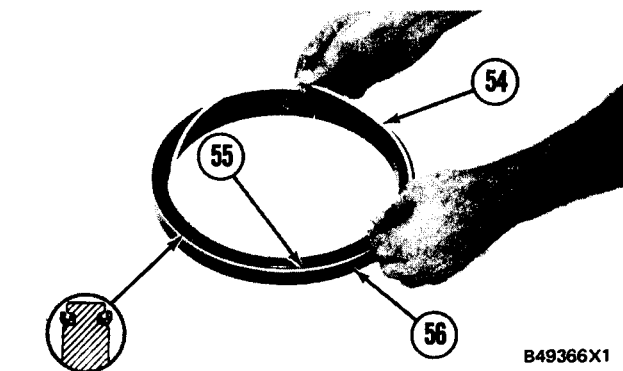

40. Install piston (56) in No. 2 clutch housing (57).

41. Install plate (58) on No. 2 clutch housing (57). Make sure small holes (59) in the plate are in alignment with the holes in the No. 2 clutch housing as shown.

42. Install tooling (C) to hold the piston and plate in the No. 2 clutch housing.

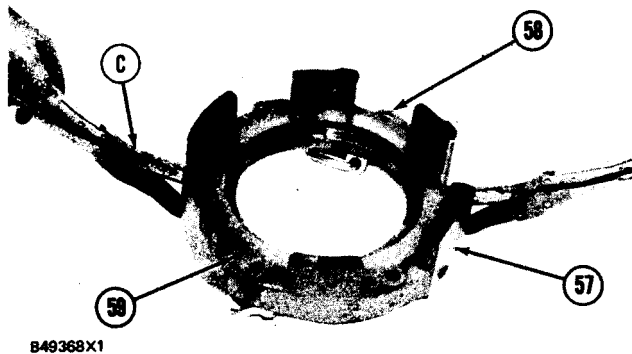

TRANSMISSION

43. Install two of tooling (B) and a hoist on No. 2 clutch housing (57). Install the clutch housing on the plate as shown. The weight of the housing is 23 kg (50 lb.).

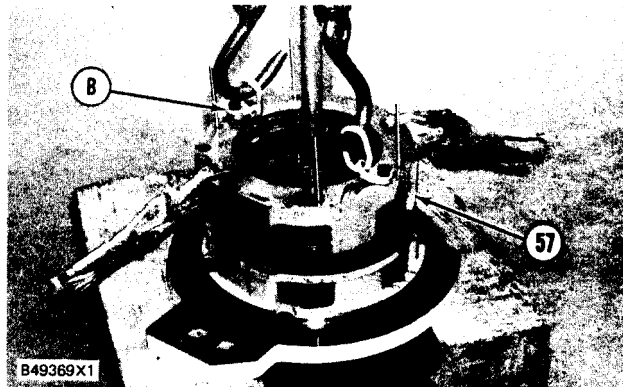

44. Install bolts (60) that hold the two housings and plate together. Tighten the bolts to a torque of 110 ± 10 N-m (80 ± 7 lb. ft.).

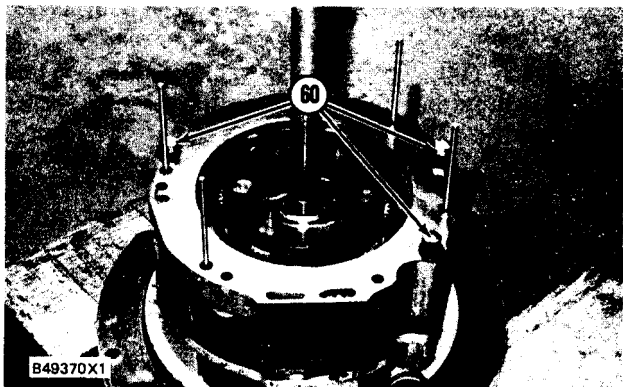

45. Lower the temperature of the two bearings and put them in position in both ends of shaft (61). Use tooling (D) to install the bearings until they are 12.0 ± 0.5 (.472 \pm .020 in.) from the end of the shaft. The inside diameter of the bearings must be $34.988 \pm .039$ mm (1.3775 \pm .0015 in.) after assembly.

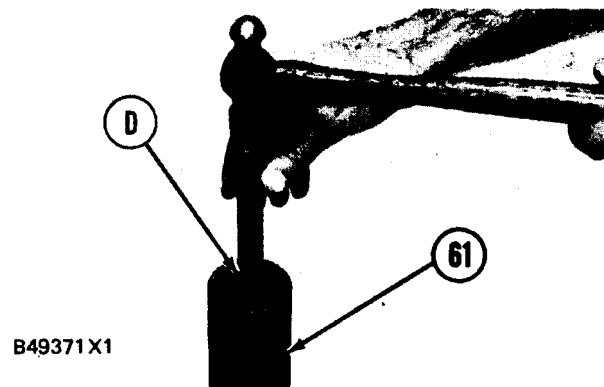

46. Heat bearing (62) to a maximum temperature of 135°C (275°F) and install it on the shaft as shown. Make sure ball (63) in the shaft fits into the notch in the bearing and the opening (slot) in the bearing is toward the top of the shaft.

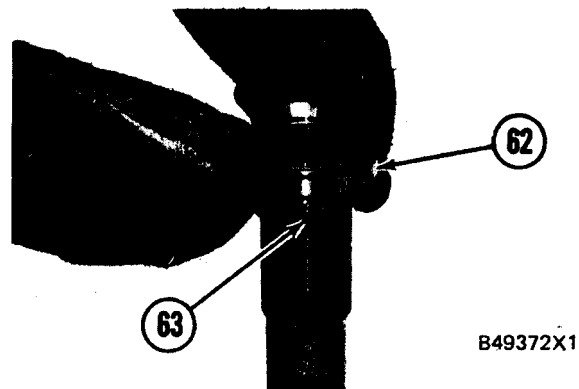

TRANSMISSION

47. Install gear (64) on shaft (61) as shown.

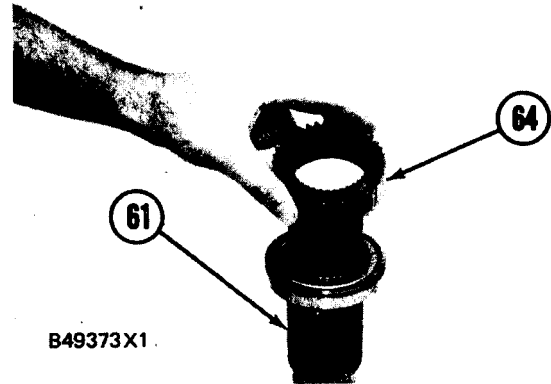

48. Use tool (E) to install ring (65) on the end of the shaft.

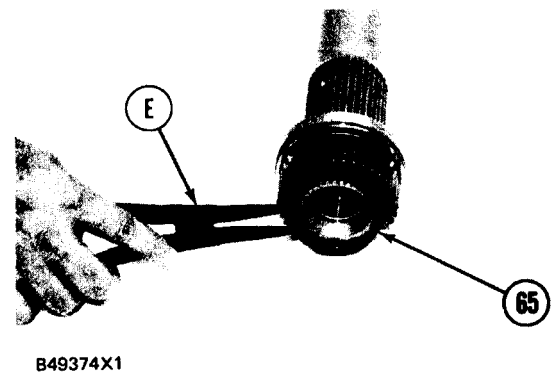

49. Install shaft (61) over shaft (4) as shown.

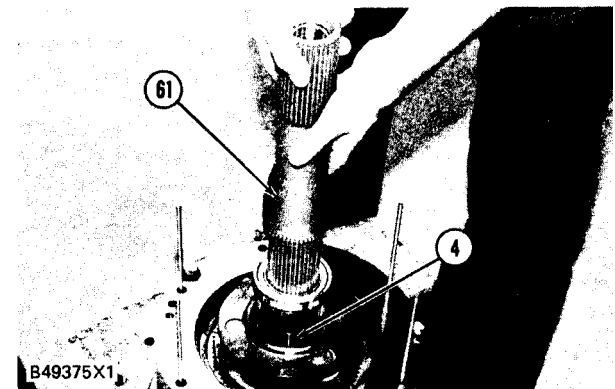

51. Install bearing (69) in gear (68).

52. Install washers (67), bearings (68) and washers (70) in the carrier.

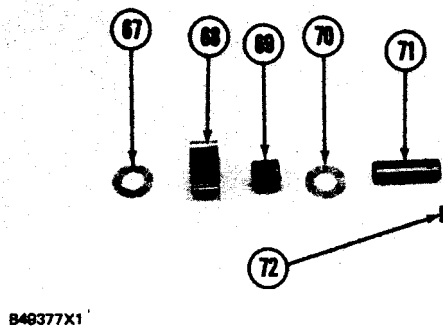

TRANSMISSION

53. Install shafts (71) in carrier (73) to hold the washers, bearings and gears in place.

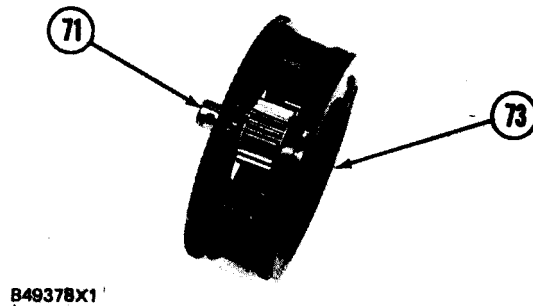

54. Use a hammer and punch to install pins (72) in the carrier that hold the shafts in place.

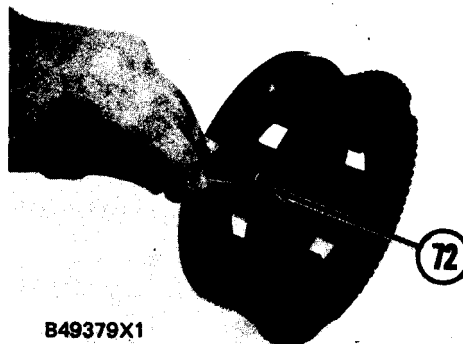

55. Install ring (74) in the groove of the carrier as shown.

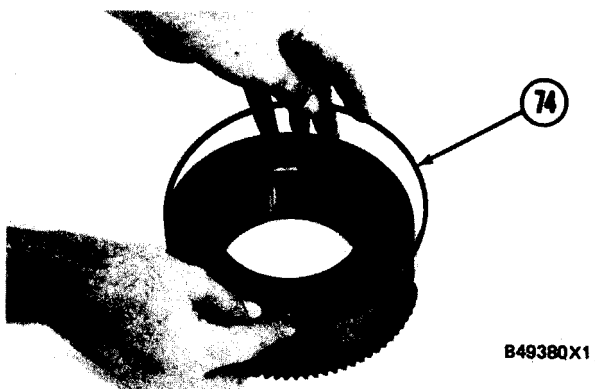

56. Make a compression of ring (74) and install carrier (73) on gear (75). Install the carrier on the gear until the ring fits into the groove in the gear.

57. Install carrier (73) and gear (75) in the No. 2 clutch housing. Make sure all gear teeth are correctly engaged.

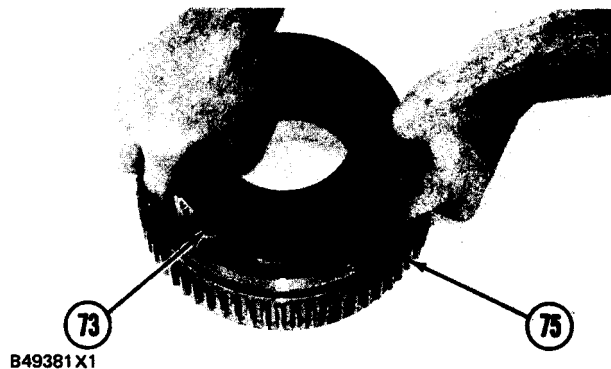

POWER TRAIN

TRANSMISSION

58. Install three discs (76) and two plates (77) (fourth speed). Start and stop with a disc as shown.

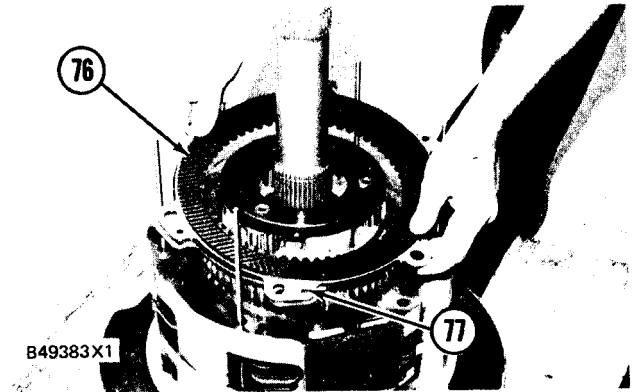

59. Install springs (78) on rods (49).

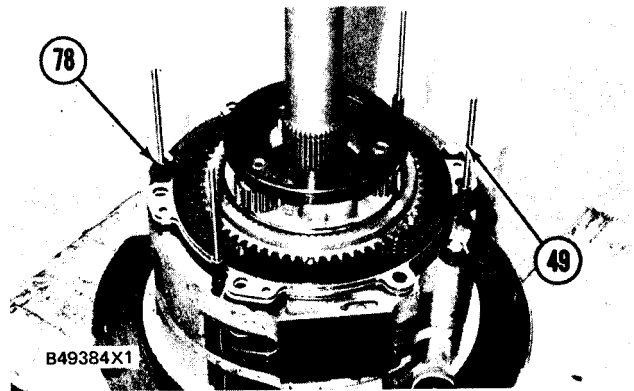

60. Install rings (79) and (81) on piston (80). Make sure the lips of the rings are as shown on the piston.

61. Install tooling (F) on No. 3 and 4 clutch housing (82).

62. Install piston (80) in No. 3 and 4 clutch housing (82) as shown. Make sure that the lips of the seals are down.

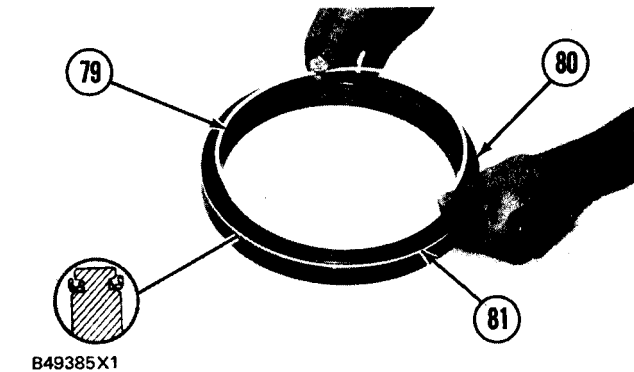

63. Install plate (83) on the clutch housing as shown. Make sure the larger holes in the plate are in alignment with the larger holes in the clutch housing.

64. install tooling (G) to hold plate (83) to the clutch housing.

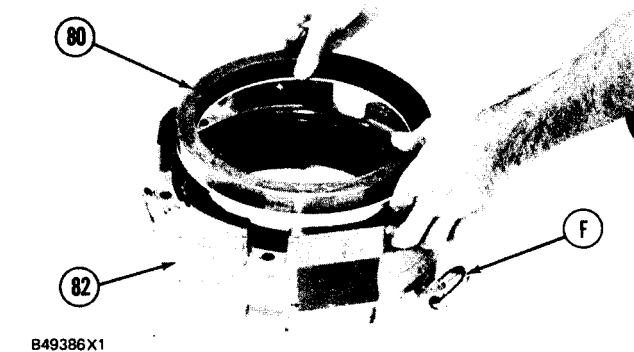
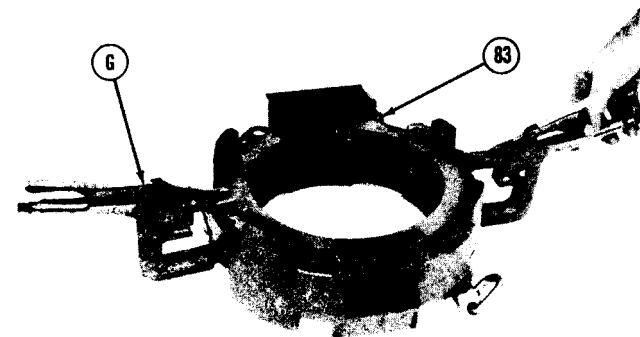

TRANSMISSION

- 65. Fasten a hoist to No. 3 and 4 clutch housing (82) and install on the No. 2 clutch housing as shown.
- 66. Install rings (84) and (86) on piston (85). Make sure the lips of the rings areas shown on the piston.
- 67. Install piston (85) in the No. 3 and 4 clutch housing as shown. Make sure that the lips of the seals are down.
- 68. Install plate (86) in gear (87).
- 69. Install ring (88) in the gear that holds the plate in place.
- 70. Install gear (87) and the plate in the No. 3 and 4 clutch housing as shown. Make sure the gear teeth on the gear are in alignment with the carrier gears.

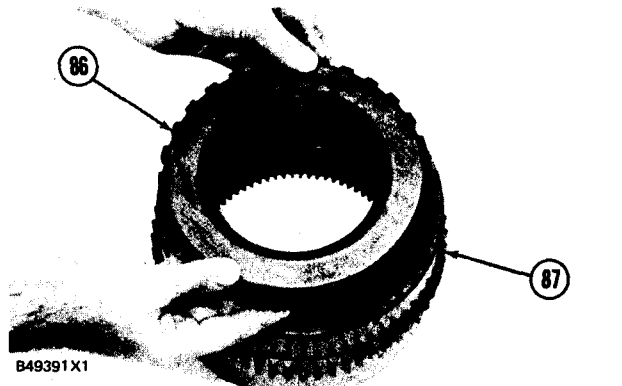
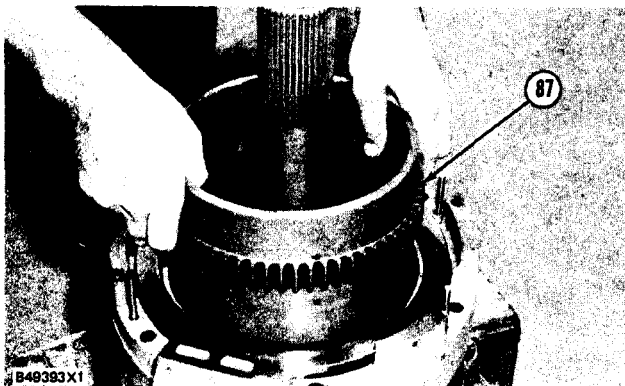
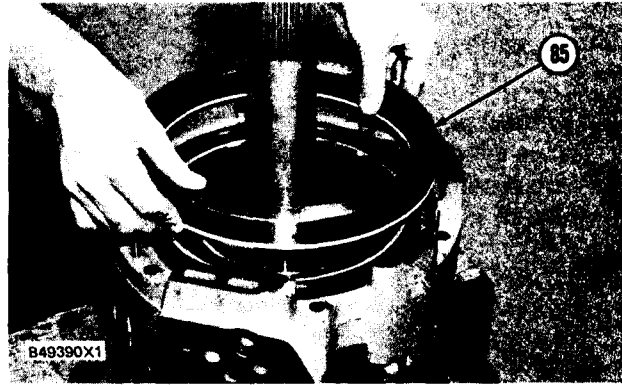
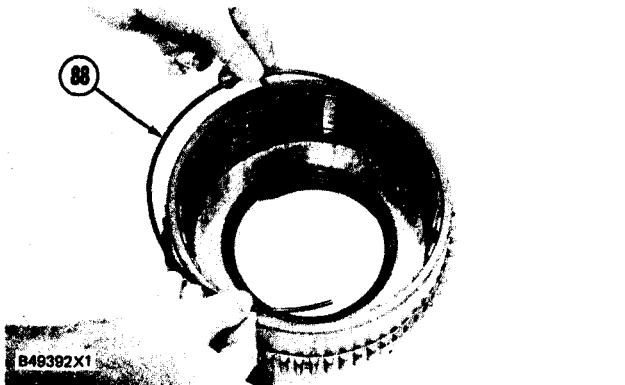
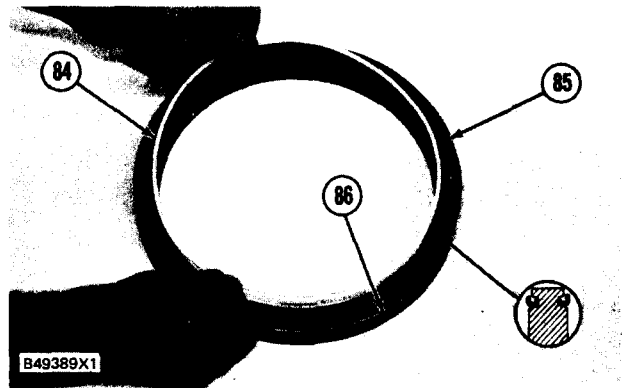
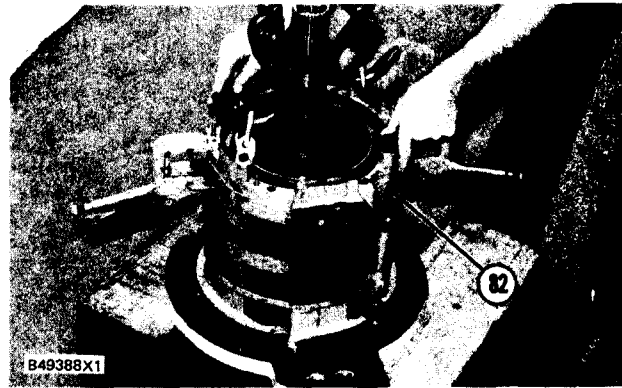

TRANSMISSION

71. Install four discs (89) and three plates (90) (second speed) in the gear. Start and stop with a disc.
72. Install gear (91) as shown.
73. Install ring (92) in the groove of the shaft with tool (A) as shown.
74. Heat carrier (94) to a temperature of 127° to 166° C (260° to 330° F) for a maximum of ten minutes and install it on housing (95) so the part number can be seen. Install the pinto hold carrier (94) in position. Install rings (93) on the carrier as shown.

NOTE: Use the method below only for non-metal rings to make them ready for installation.

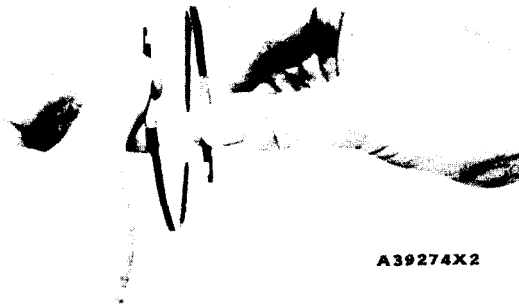
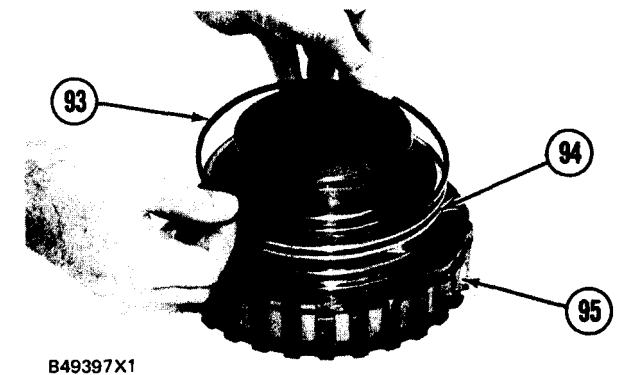
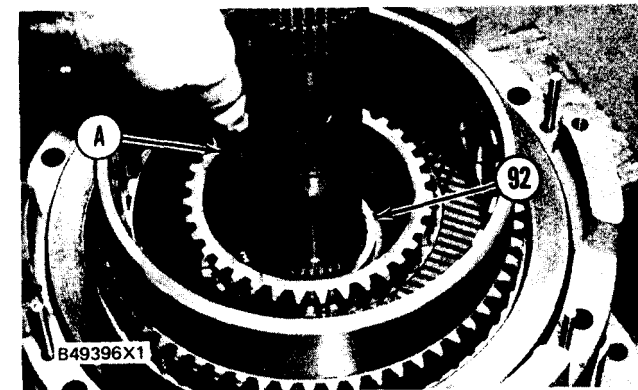
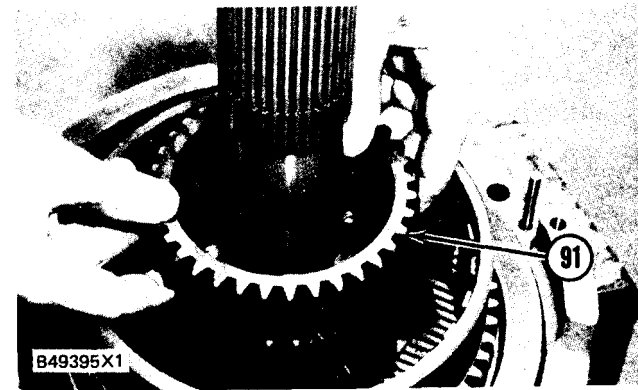
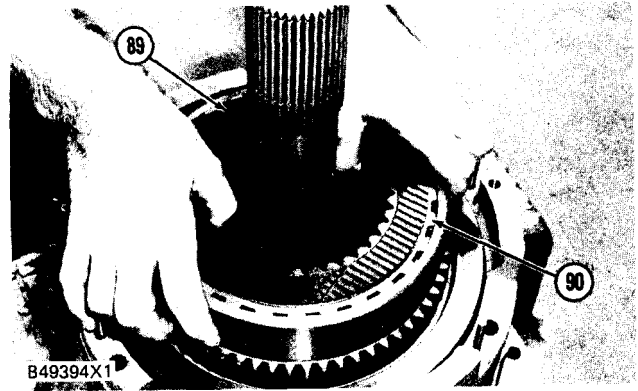

FIGURE 1. CORRECT METHOD TO MAKE (NON-METAL) NEW RINGS READY FOR INSTALLATION



FIGURE 2. WRONG METHOD TO MAKE (NON-METAL) NEW RINGS READY FOR INSTALLATION

TRANSMISSION

75. For models 950BNSCE and 950BSCE only, repeat step 74 to install carrier and ring (139) on gear assembly (96).

76. Put housing (95) in position on gear assembly (96) as shown. Install bevel spring (97) in the housings as shown. make sure that the outside edges of the bevel springs make contact first.

77. Install plate (98) on the housing.

78. Use steel spacers and a press to put the plate and bevel springs under compression. Install ring (99).

79. Install ring (100) on the housing as shown.

80. Put the housing and gear in position in the gear as shown. Use tool (H) to make a compression of ring (100) that holds the housing in the gear.

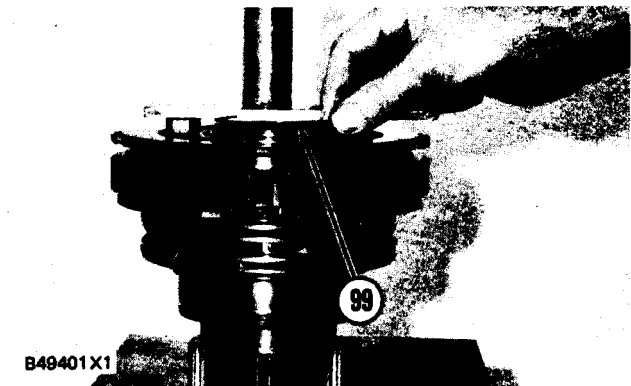
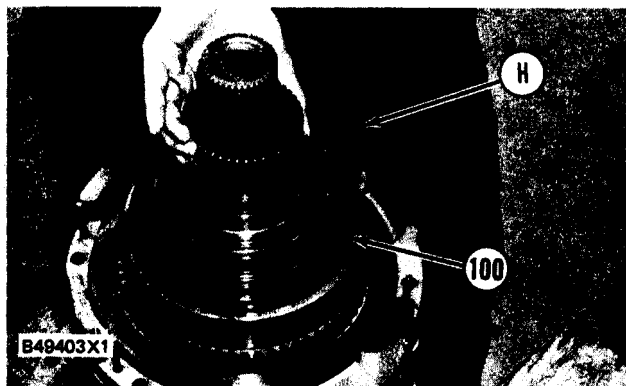
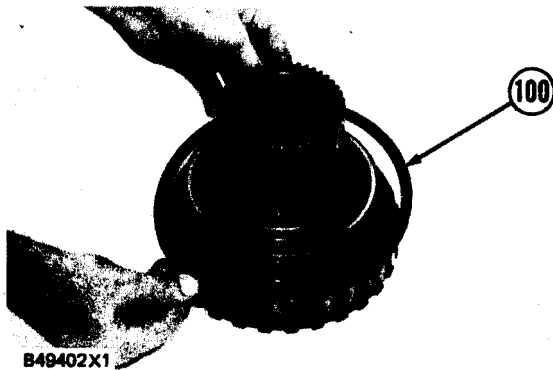
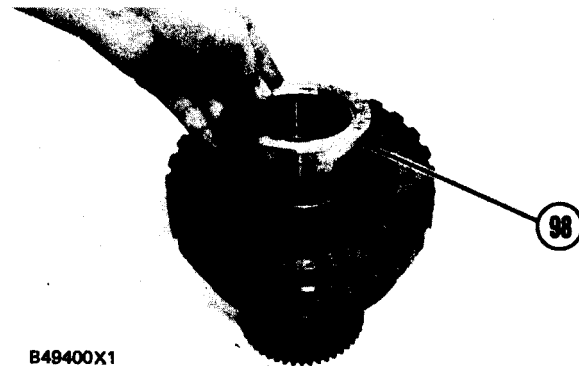
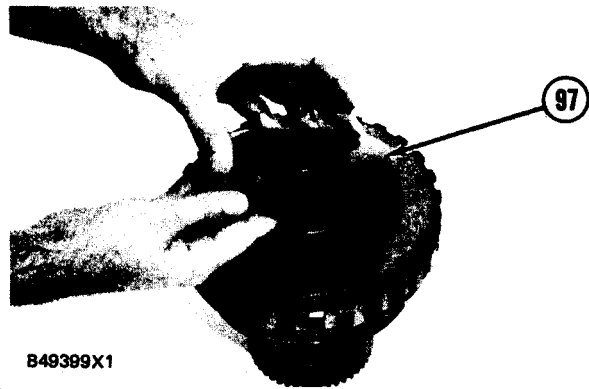
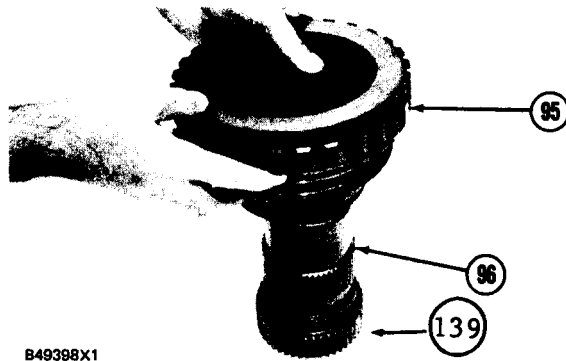

TRANSMISSION

81. Install two plates (102) and two discs (101) (third speed) on the housing as shown. Start with a plate and end with a disc. Make sure the small hole in plate (102) is installed on rods (49) as shown.

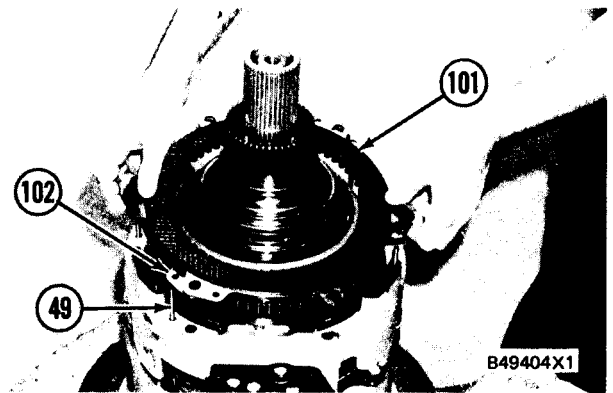

82. Install springs (103) on the rods.

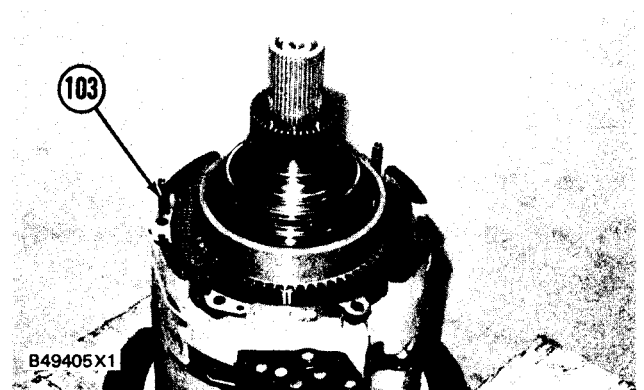

83. Install two of tooling (B) on housing (105).

84. Install bearing (104) in housing (105) with tooling (J).

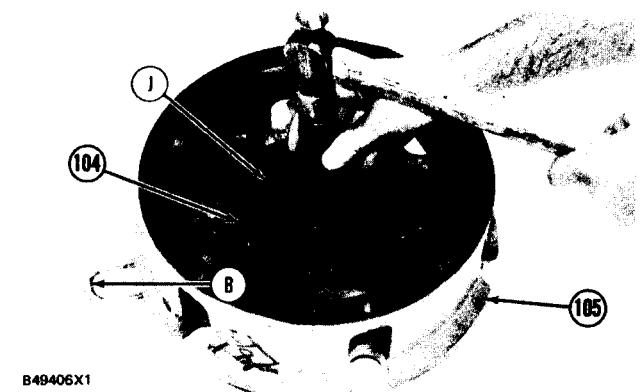

85. Use tool (A) to install ring (106) in the housing.

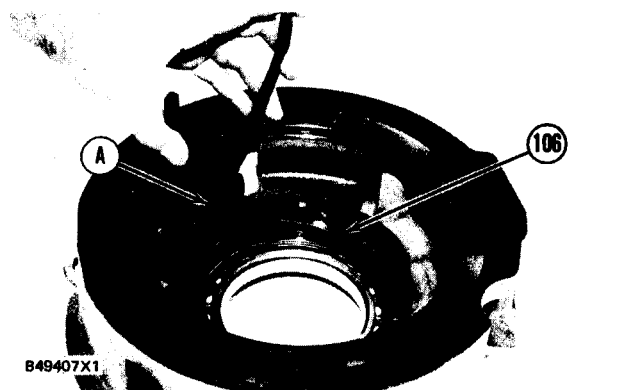

86. Install a hoist to tooling (A) and put housing (105) in position on the No. 3 and 4 clutch housing. The weight of the housing is 29 kg (64 lb.).

NOTE: Make sure the dowel in gear (96) and the notch in bearing (104) are in alignment. If necessary turn gear (96) to make the alignment.

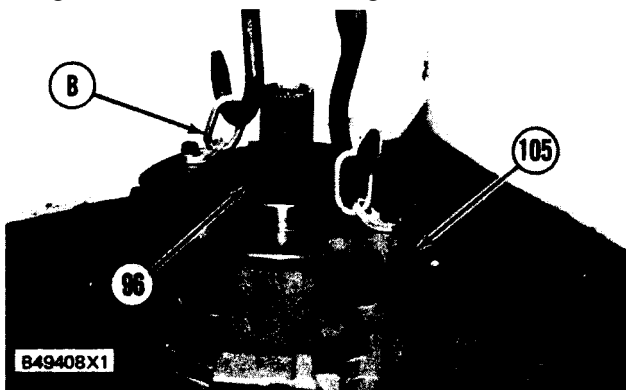

TRANSMISSION

87. Install bolts (107) and tighten them to a torque of $110 \pm 10 \text{ N}\cdot\text{m}$ ($80 \pm 7 \text{ lb. ft.}$).

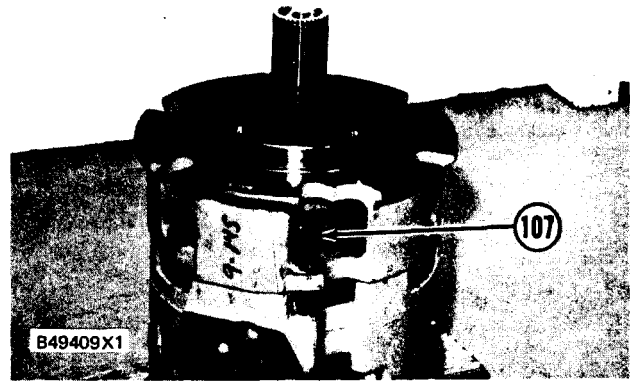

88. Use tool (A) to install ring (108) on the housing.

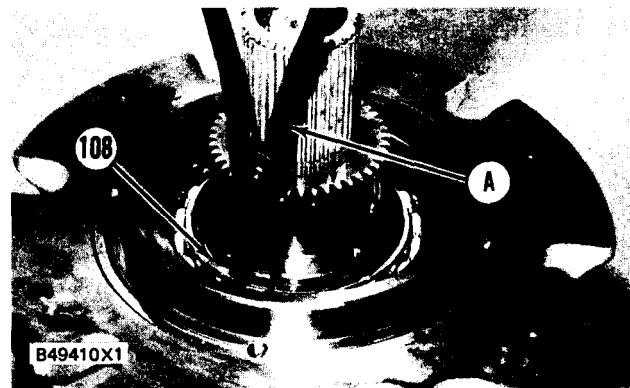

89. Use tool (A) to install ring (109) on the shaft.

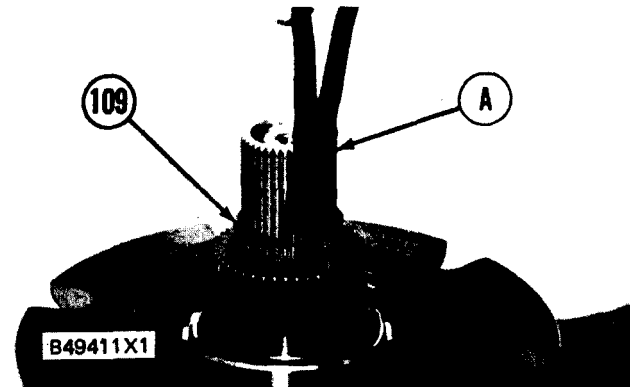

90. Install gear (110) on the housing as shown.

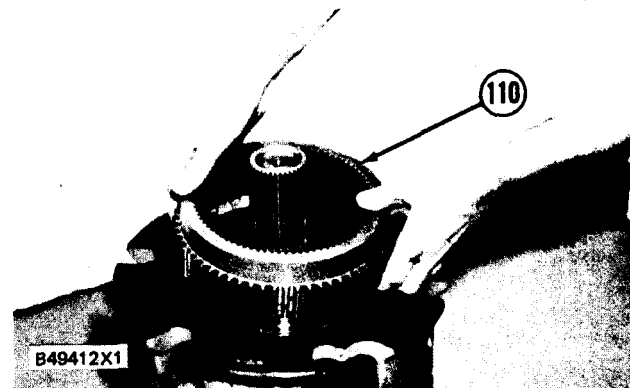

91. Install four discs (111) and three plates (112) on the gear. Start and stop with a disc.

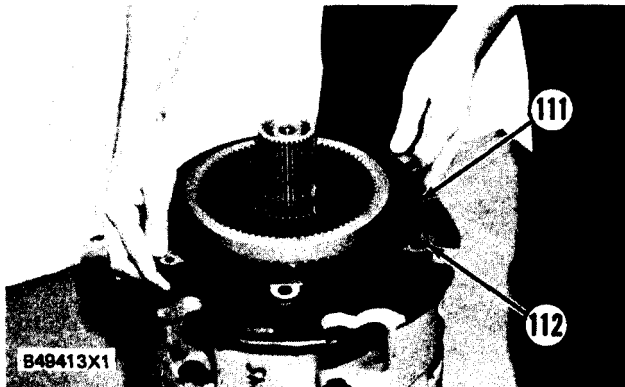

TRANSMISSION

92. Install springs (113) in the holes on the housing as shown.

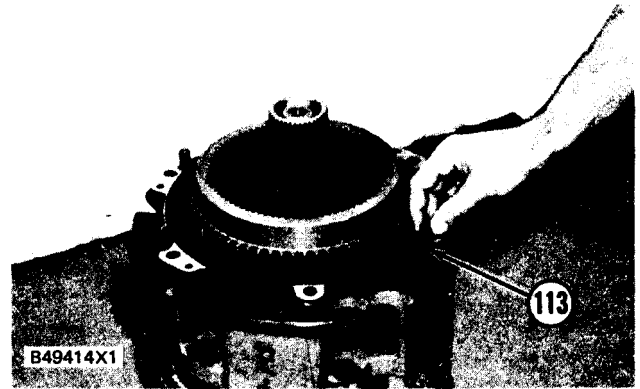

93. Install pins (114) in No. 6 clutch housing (115) as shown.

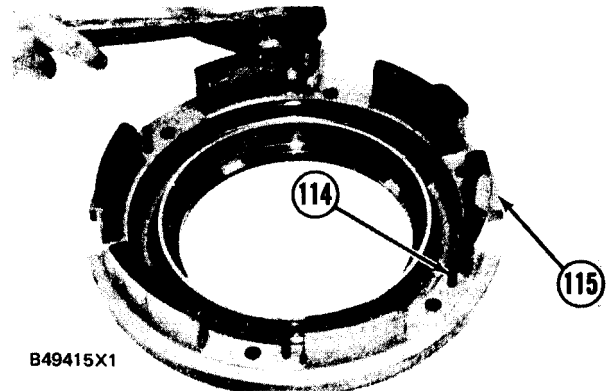

94. Install rings (116) and (117) on piston (118). Make sure the lips of the rings areas shown on the piston.

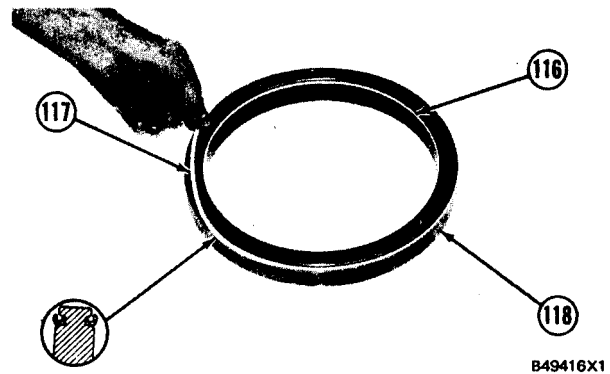

95. Install piston (118) in the No. 6 clutch housing as shown.

96. Install plate (119) in the No. 6 clutch housing as shown.

97. Use tooling (C) to hold the plate in the clutch housing.

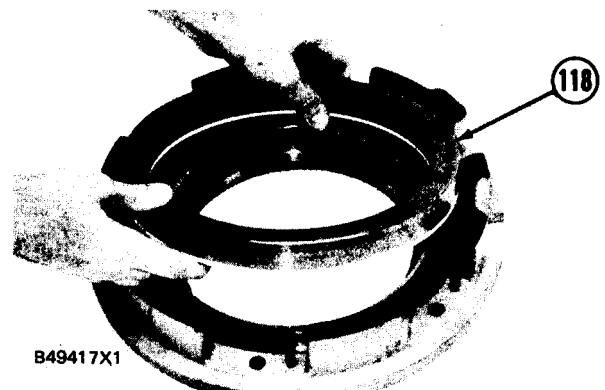

TRANSMISSION

98. Install ½"-13 NC 10" long guide bolts (120) in the housing as shown.

99. Install No. 6 clutch housing (115) on the housing as shown.

100. Install bolts (121) that hold the No. 6 clutch housing to the housing. Tighten the bolts to a torque of $110 \pm 10 \text{ N}\cdot\text{m}$ ($80 \pm 7 \text{ lb. ft.}$).

101. Install bearings (124) in gears (123).

102. Install washers (122), gears (123) and washers (125) in the carrier.

103. Install shafts (126) in carrier (128) to hold the washers, gears and bearings in place.

104. Use a hammer and a punch to install pins (127) into the carrier and shafts.

NOTE: If pins (127) are damaged, a replacement will be necessary.

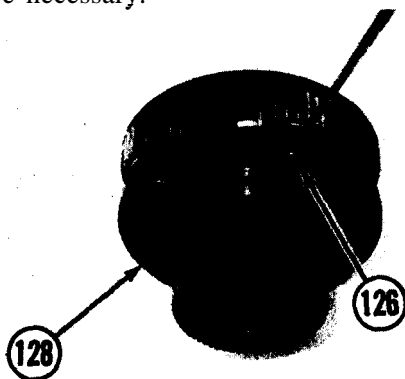
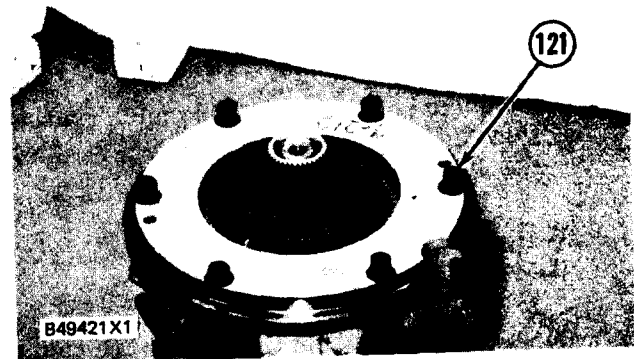
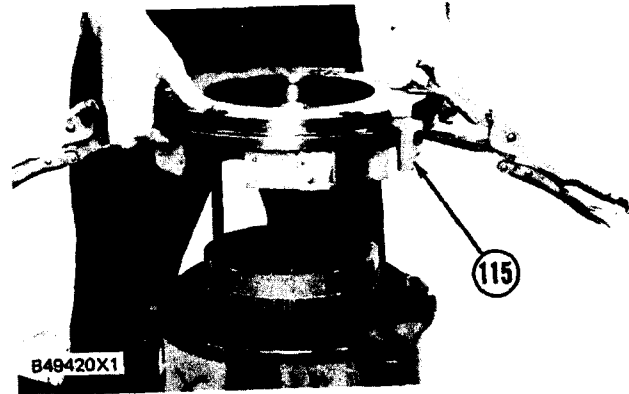
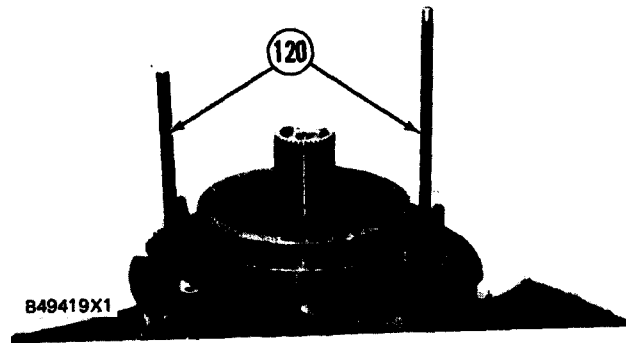

B49423X1

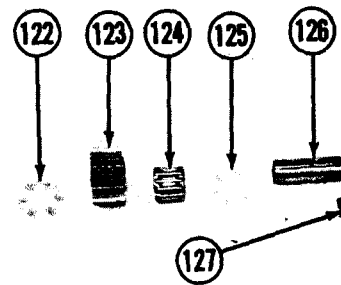

B49422X1

TRANSMISSION

105. Install ring (129) on the carrier.
106. Make a compression of ring (129) and install carrier (128) in the gear until the ring fits into the groove of the gear.
107. Use tool (A) to install ring (130) on the shaft.
108. Check to make sure the pistons are free in their clutch housings with tool (K) as follows:
 - a) Put air free of water under a pressure of 690 to 1030 kPa (100 to 150 psi) into each of the six oil passages.
 - b) If the pistons do not move, put a small amount of clean SAE 30 oil in each passage. Check for movement again. If the pistons still do not move, the transmission must be disassembled and the pistons and seal rings checked.
109. Install seals (131) and (132) on the transmission case.
110. Fasten two of tooling (B) and a hoist to the No. 1 clutch housing as shown. Lower the transmission into the transmission case. Install the two bolts that hold them together. The weight of the transmission is 293 kg (650 lb.).

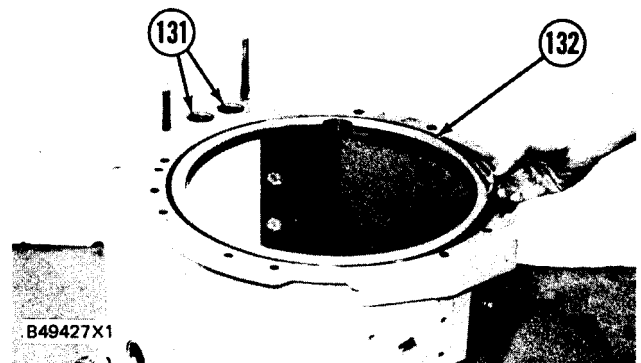
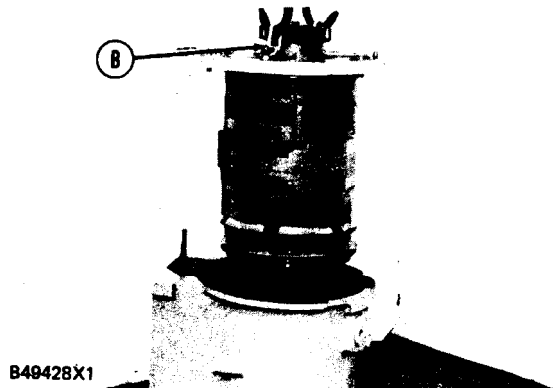
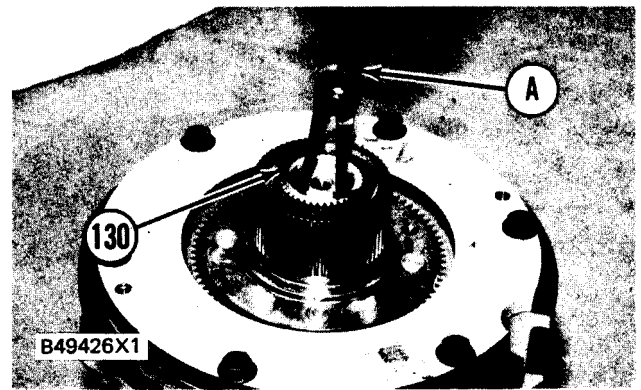
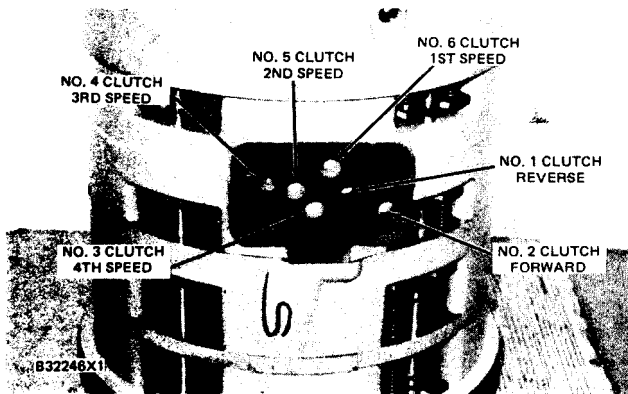
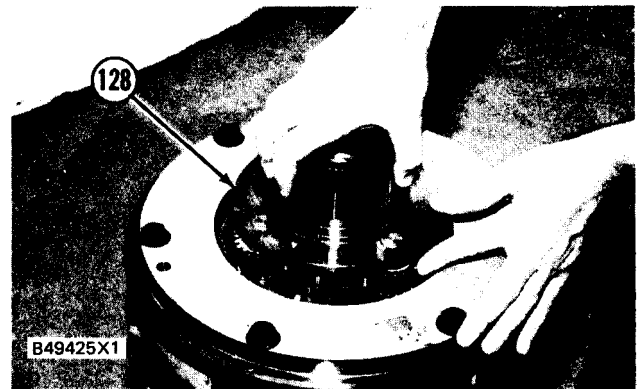
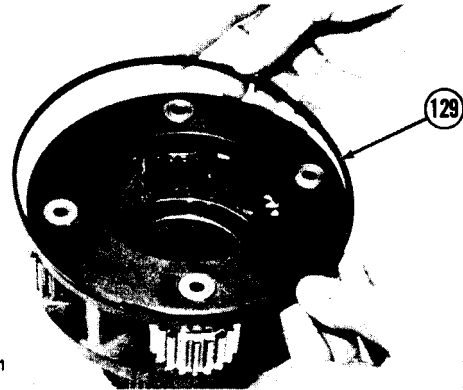

TRANSMISSION

111. Fasten tooling (B) and a hoist to the transmission and carefully lower it on the transfer gear case as shown. The weight of the transmission and case are 340 kg (750 lb.).

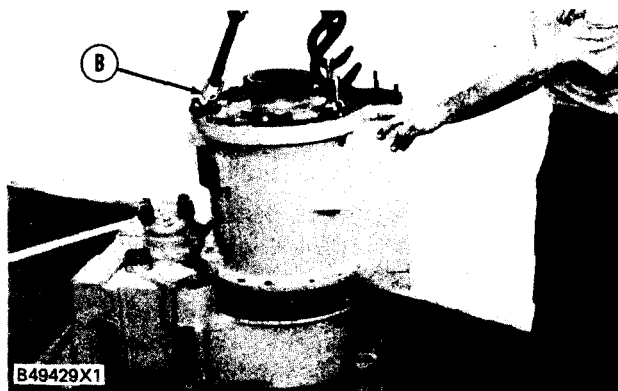

112. Install bolts (133) that hold the transmission to the transfer gear case.

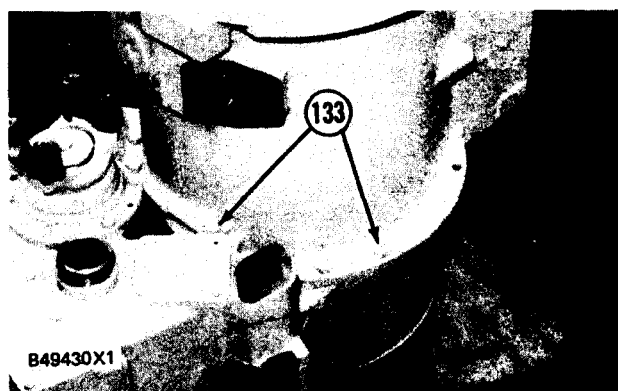

113. Install three seals (134) and seal (135) on the No. 1 clutch housing.

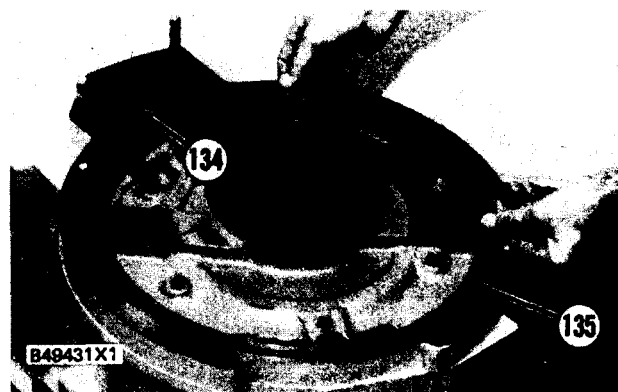

114. Install seal (137) on elbow (136).

115. Install elbow (136) on the transfer gear case and transmission.
end by:

- a) install transmission hydraulic control valve
- b) connection of torque converter to transmission

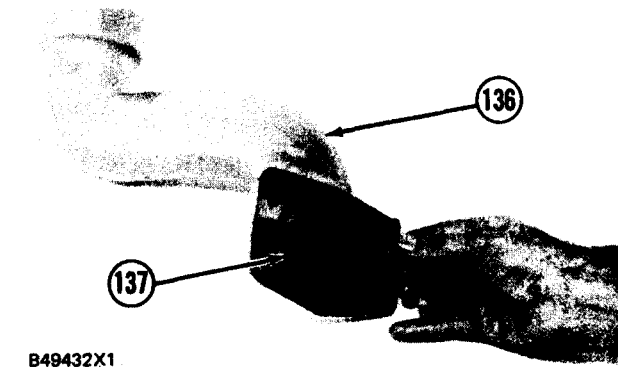
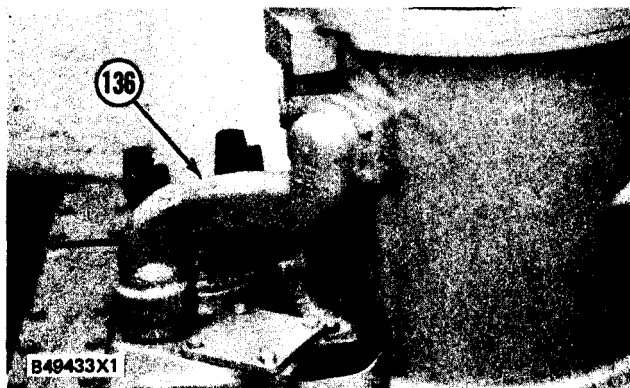

TRANSFER GEARS

DISASSEMBLE TRANSFER GEARS 3159-15

Tools Needed		A	B	C
1P520	Driver Group	1		
1P2322	Puller Assembly	1		
8B7556	5/8" Adapter		1	
8B7548	Puller Assembly		1	
8B7560	Step Plate		1	
8H684	Ratchet Box Wrench		1	
8B7551	Bearing Puller Attachment		1	

start by:

a) separation of transmission from transfer gears (see DISASSEMBLE TRANSMISSION)

1. Fasten a hoist and turn the transfer gears over. Put the transfer gears on blocks with the back of the case up as shown. The weight of the unit is 231 kg (510 lb.).
2. Remove the bolt and plate (1) from the back of the bearing cage.

Note: Cover (2) is replaced with supplemental steering pump. See Remove Supplemental Steering Gear Pump.

3. Remove the nuts, cover (2) and the gasket from the back of the bearing cage.
4. Remove bolts (3) that hold bearing cage (4) to the case.

5. Use two 3/8 "-16 NC forcing screws (5) to loosen bearing cage (4) and the O-ring seal from the case. Remove bearing cage (4) and the shims. Keep the shims together for assembly purposes.

6. Remove O-ring seal (7) and bearing cup (6) from bearing cage (4).

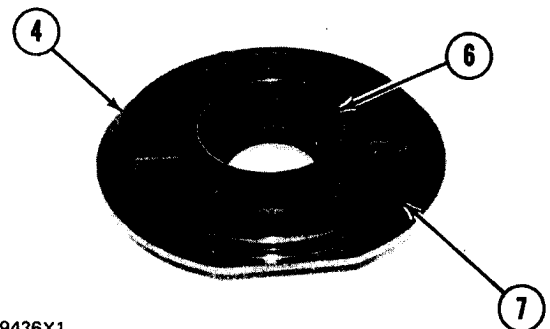
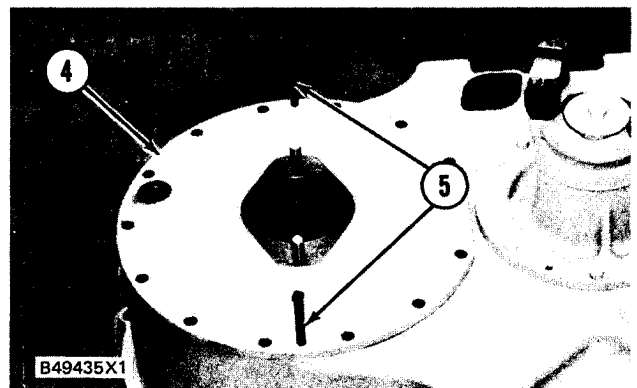
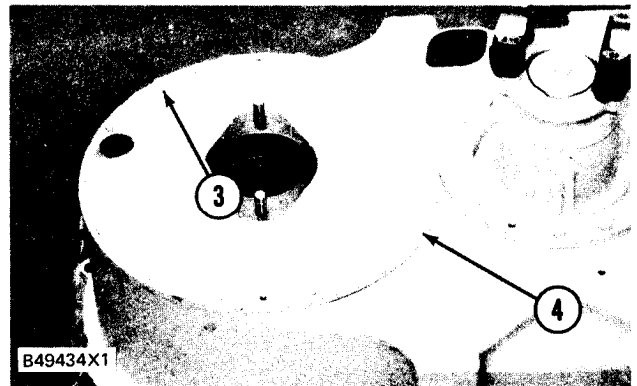
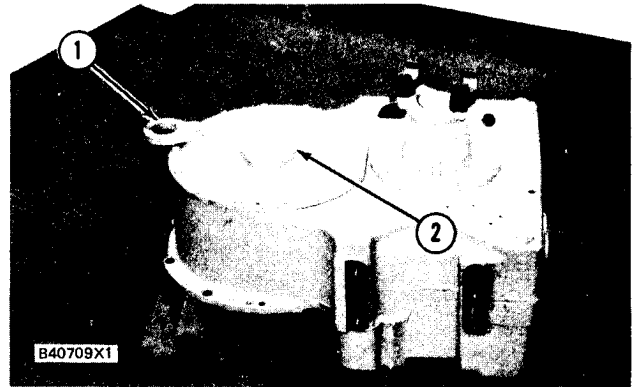

TRANSFER GEARS

- Fasten a hoist and remove gear (8) and the bearing cones from the case. The weight of the unit is 23 kg (50 lb.).

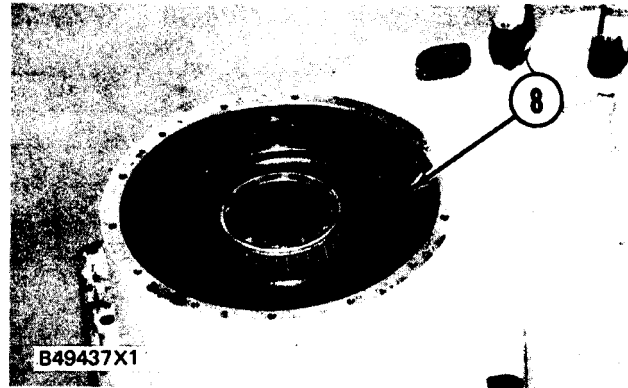

- Use tooling (A) to remove bearing cones (9) from each side of the gear.

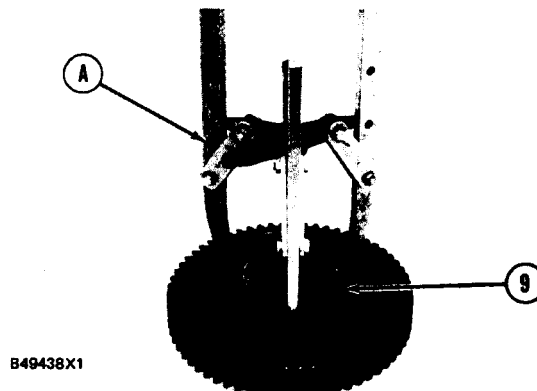

- Remove bearing cup (10) from the case.

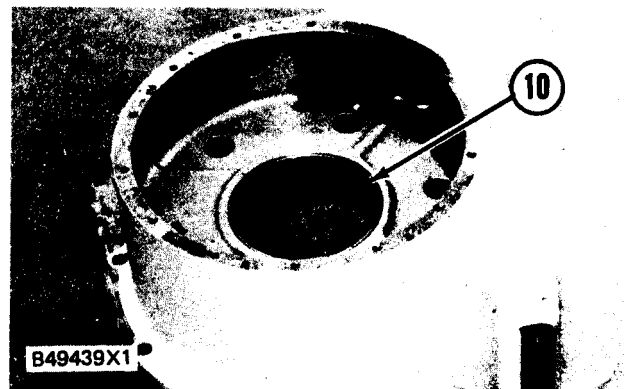

- Remove bolt (11), retainer (13), the O-ring seal and yoke (12) from the output shaft.

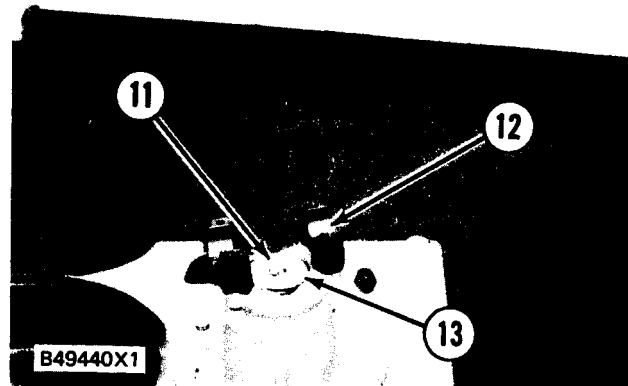

TRANSFER GEARS

11. Remove bolts (15) that hold cage (14) to the case.

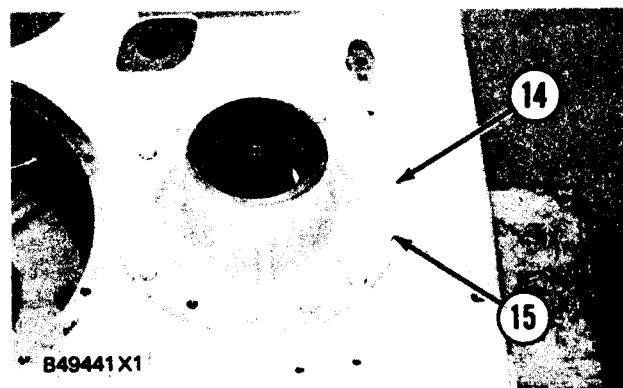

12. Use two 3/8''-16 NC forcing screws (16) to loosen cage (14) and the O-ring seal from the case.

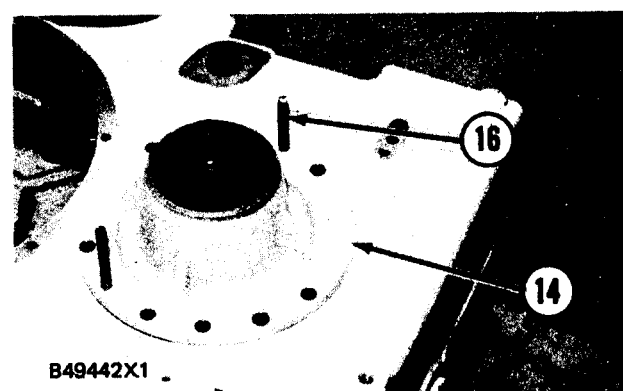

13. Remove cage (14), the O-ring seal and the shims from the case.

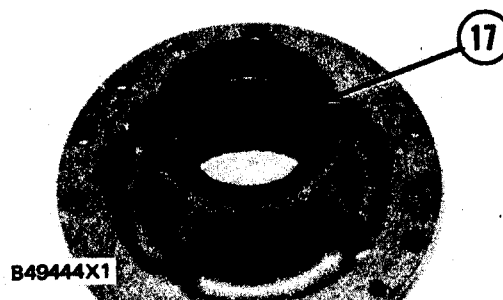

14. Remove seal (17) from the cage.

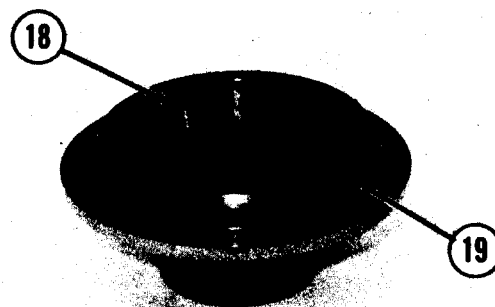

15. Remove O-ring seal (19) and bearing cup (18) from the cage.

TRANSFER GEARS

16. Remove spacers (20) from the output shaft.

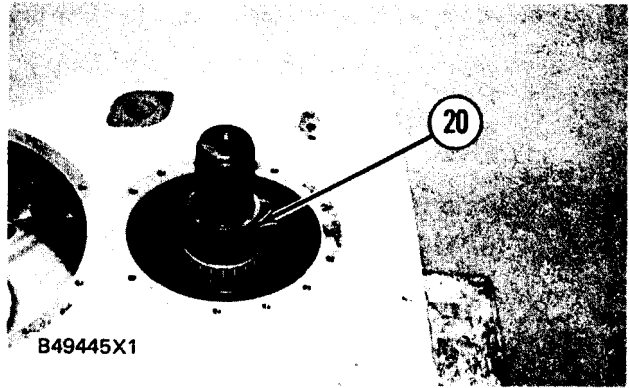

17. Fasten a hoist and put the transfer gear case in a vertical position. The weight of the unit is 186 kg (410 lb.).

18. Remove the bolt, retainer (21), the O-ring seal and yoke (22) from the output shaft.

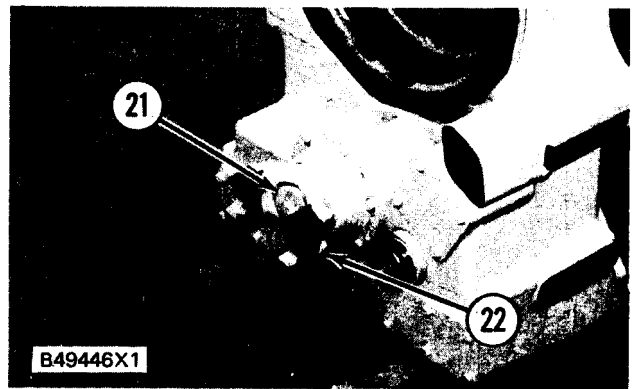

19. Remove bolts (24) that hold cage (23) to the case.

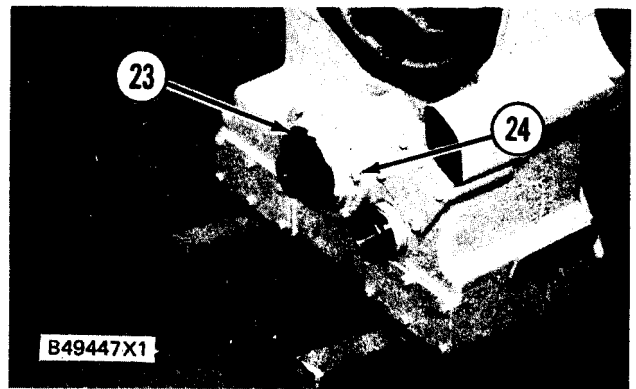

20. Install two 3/8"- 16 NC forcing screws (25) to remove cage (23) from the case.

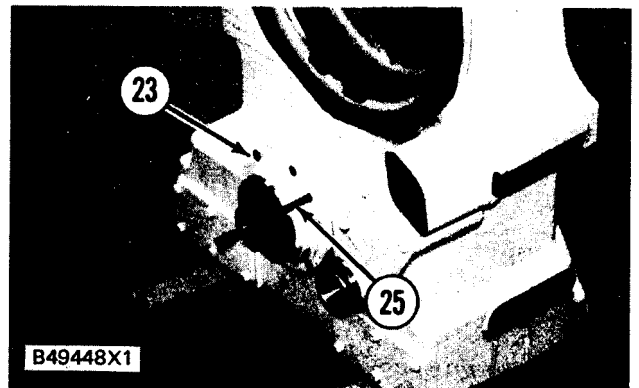

21. Remove seal (26) from the cage.

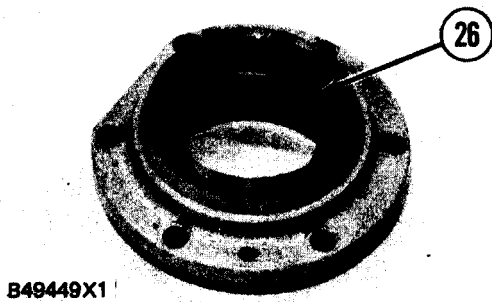

TRANSFER GEARS

22. Remove bearing cup (27) and O-ring seal (28) from the cage.

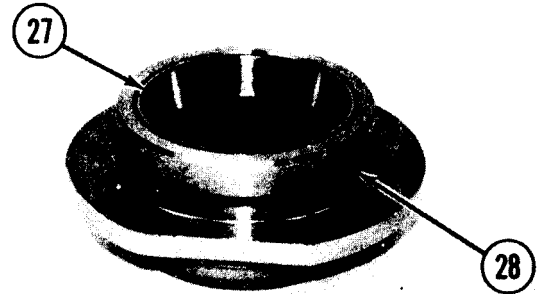

B49450X1

23. Fasten a nylon strap and a hoist to hold gear (29) in position.

24. Use tooling (B) to push output shaft (31) from gear (29) and bearing cone (30).

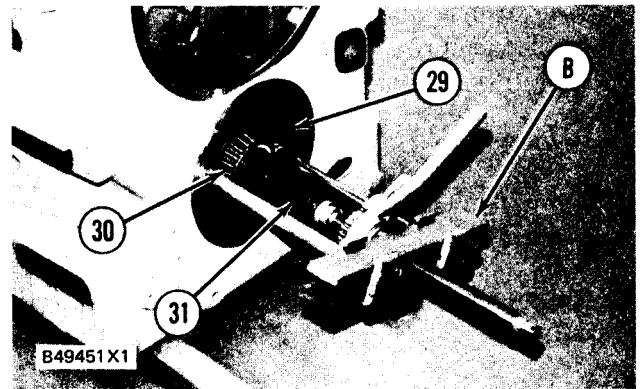

B49451X1

25. Remove gear (29) from output shaft (31).

26. Remove output shaft (31) and bearing cone (32) from the case.

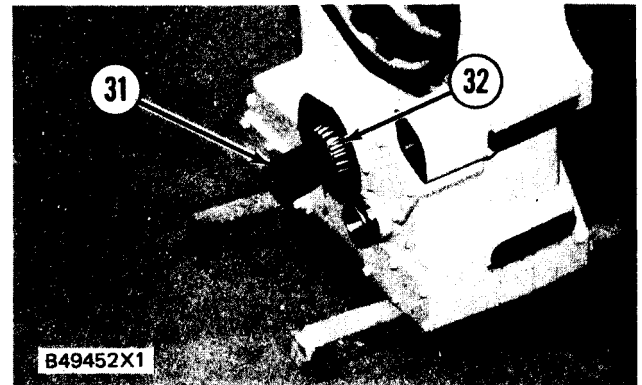

B49452X1

27. Use tool (C) and a press to push the output shaft from bearing cone (32).

NOTE: The output shaft is free to fall when the bearing cone is removed.

28. Remove gear (29) from the transfer gear case.

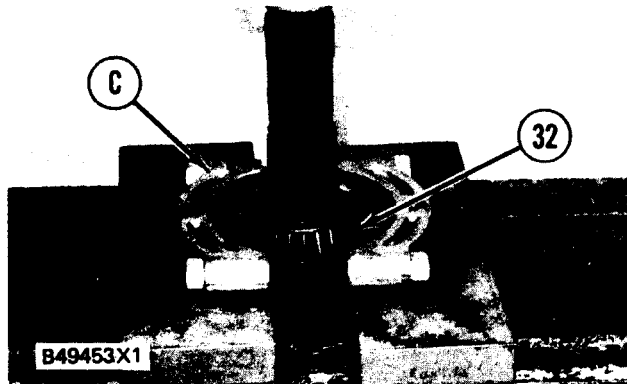

B49453X1

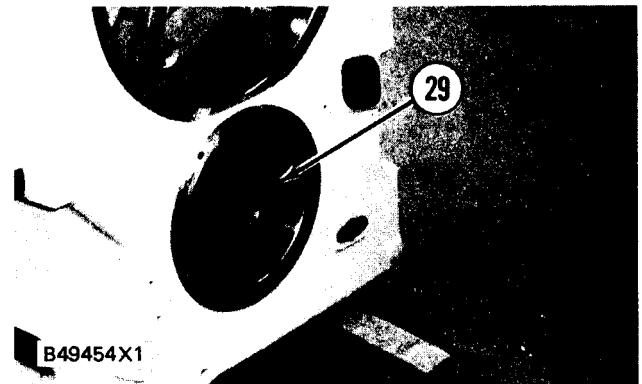

B49454X1

TRANSFER GEARS

29. Remove sleeve (33) from the case.

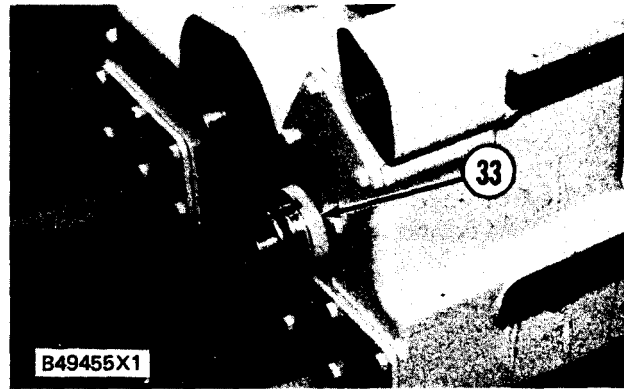

30. Remove O-ring seals (34) and (35) from the sleeve.

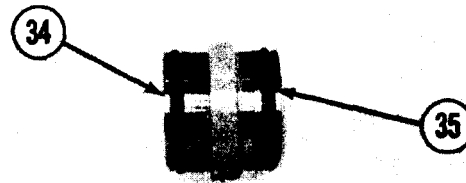

B49456X1

31. Remove bolts (36), cover (37) and the gasket from the case.

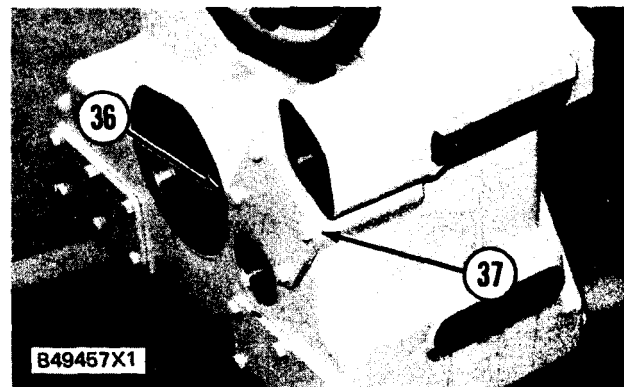

32. Remove screen (39) and tube (38) from the case.

33. Make a separation of screen (39) from tube (38).

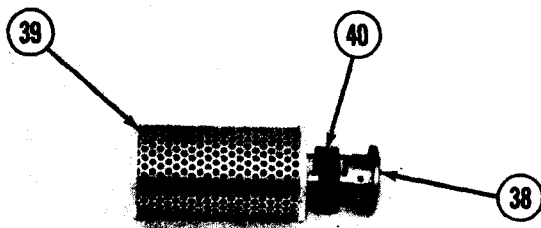

B49459X1

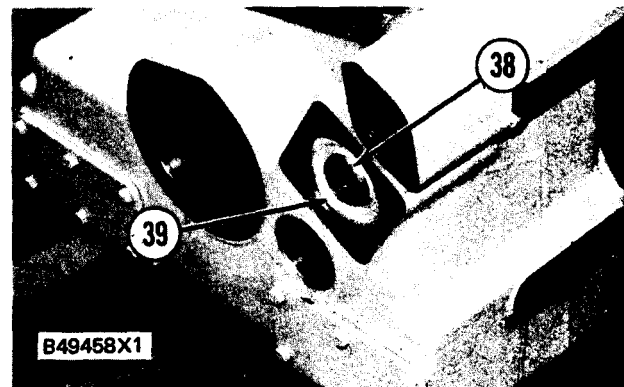

TRANSFER GEARS

B25728X3

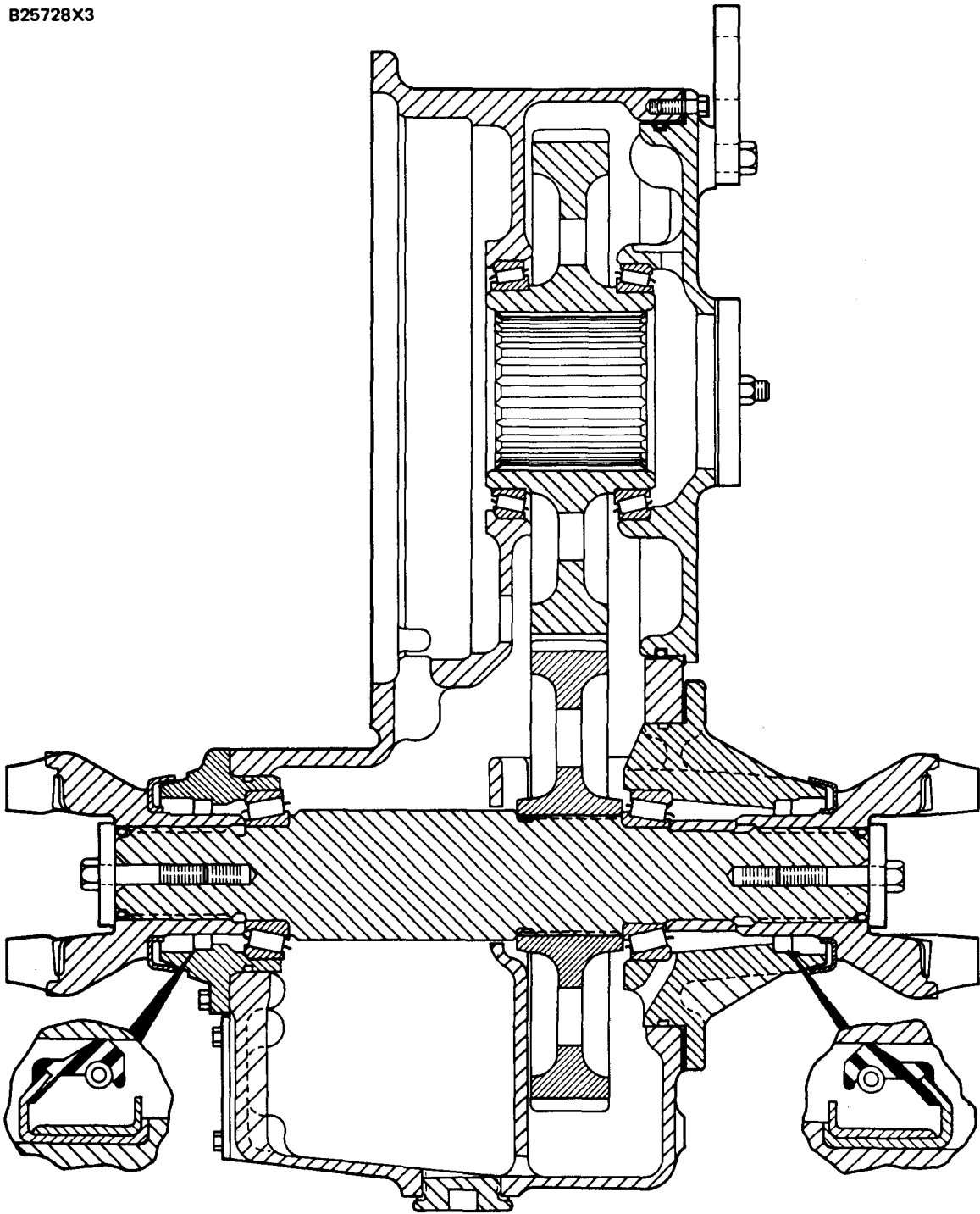

TRANSFER GEARS

ASSEMBLE TRANSFER GEARS 3159-16

Tools Needed		A	B
1P520	Driver Group	1	
8S2328	Dial Test Indicator Group		1

1. Make sure the magnets on the tube and the screen are clean and free of dirt and foreign material.

2. Make sure magnets (2) are in position on tube (3).

3. Install tube (3) into screen (1) as shown.

4. Install tube (3) and screen (1) into the case.

5. Put O-ring seal (5) in position on cover (4) and put clean power train oil on it.

6. Install cover (4) on the case.

7. Install O-ring seals (6) and (8) on sleeve (7).

8. Install sleeve (7) in the case.

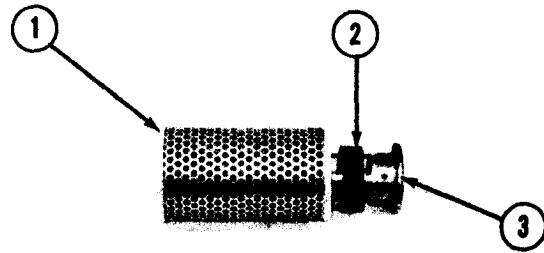

B49460X1

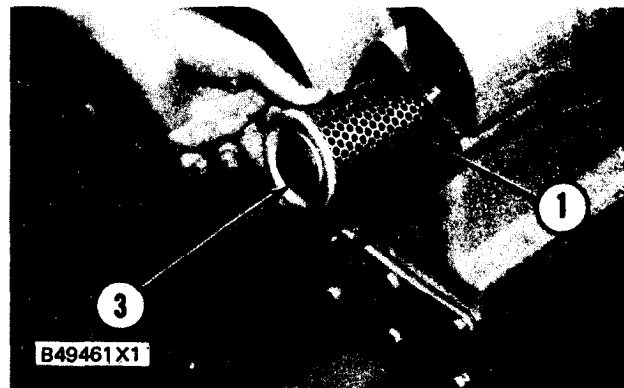

B49461X1



B49462X1

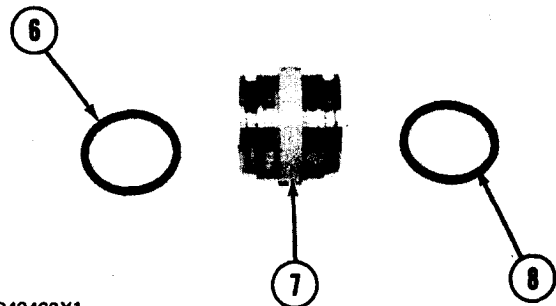

B49463X1

TRANSFER GEARS

9. Put gear (9) in position in the case as shown.

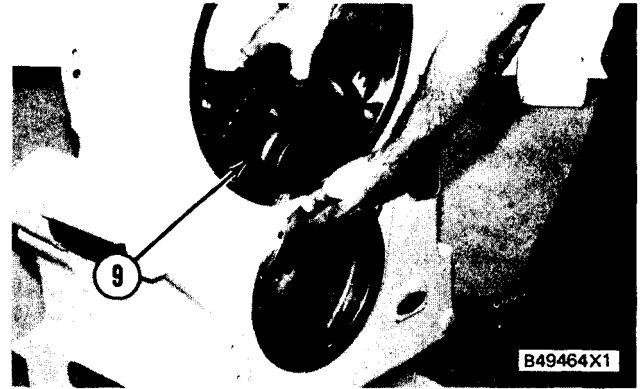

10. Heat bearing cone (10) to a maximum temperature of 135° C (275° F) and install it on output shaft (11).

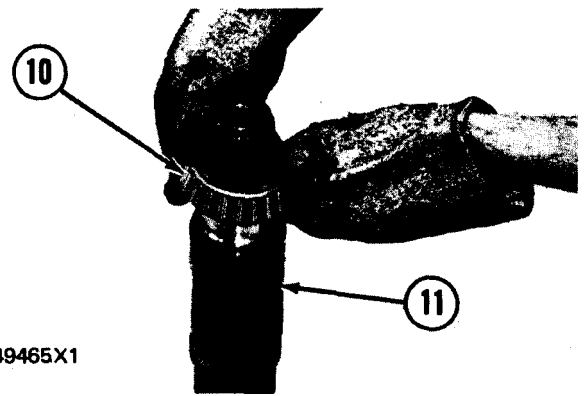

11. Put the bearing and output shaft (11) in position in the case. Gear (9) must be lifted slightly to make an alignment with the output shaft.

12. Heat bearing cone (12) to a maximum temperature of 135° C (275° F) and install it on the output shaft as shown.

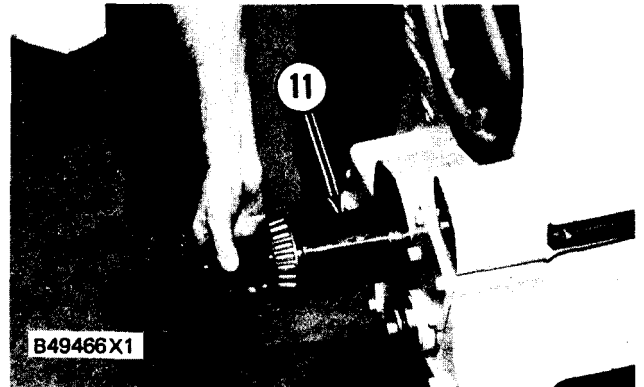

13. Lower the temperature of bearing cup (13) and install it in cage (14).

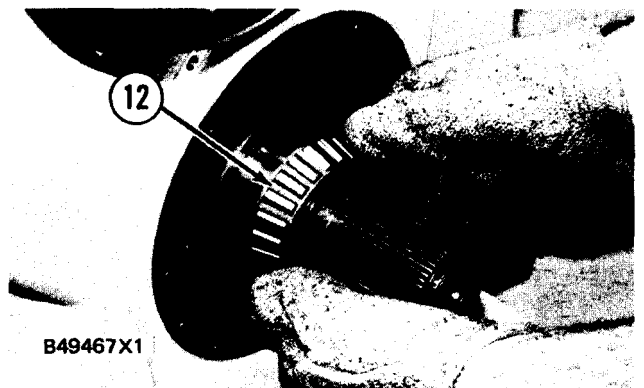
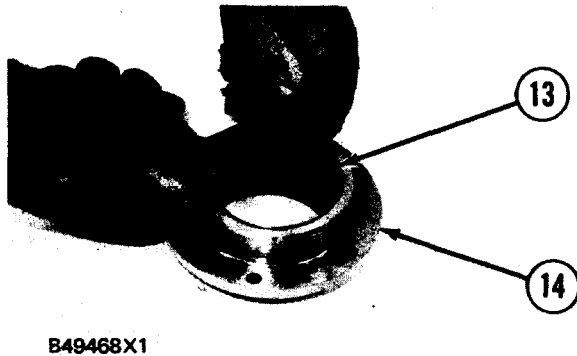

TRANSFER GEARS

14. Install O-ring seal (15) on the cage.

15. Put 7M7260 Liquid Gasket Material in the seal bore in cage (14) and let it dry. Do not put the liquid gasket material on the lip of the seal case. Use tooling (A) and install the seal in cage (14) with the lip of the seal toward the inside as shown. Put clean power train oil on the lip of the seal.

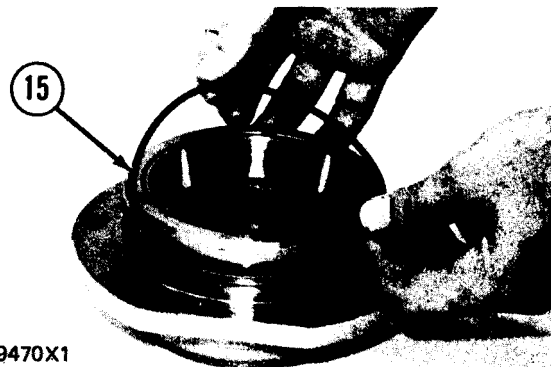

16. Put clean power train oil on the O-ring seal and install cage (14) on the case.

17. Install yoke (16) on the end of the output shaft.

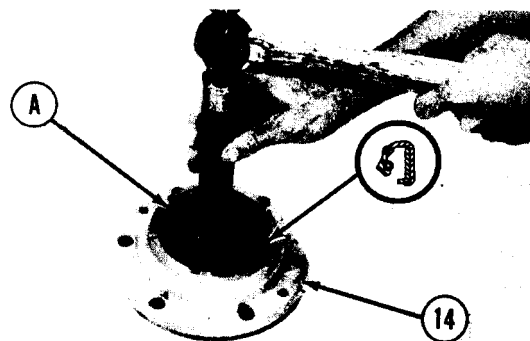

18. Install O-ring seal (18), retainer (19) and bolt (17) on the end of yoke (16). Put clean power train oil on the O-ring seal. Tighten the bolt to a torque of $110 \pm 10 \text{ N}\cdot\text{m}$ ($80 \pm 7 \text{ lb. ft.}$).

19. Use a hoist and put the transfer gear case in a horizontal position.

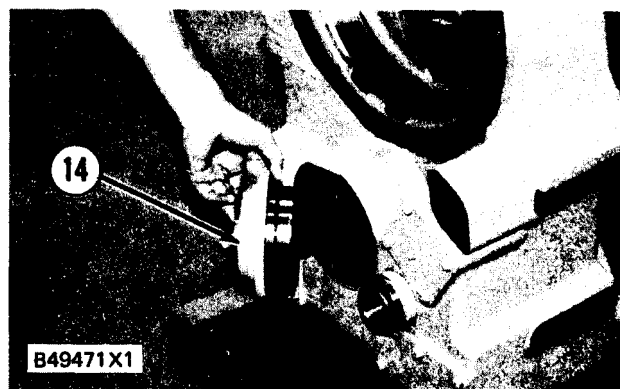

20. Install spacer (20) on the end of the output shaft.

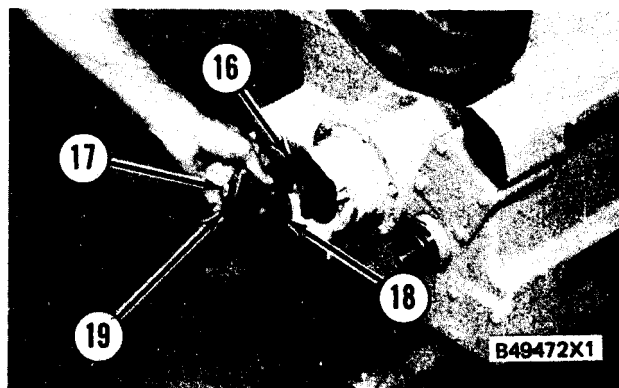
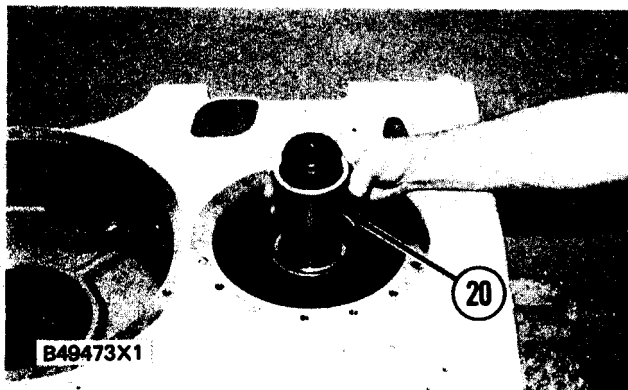

POWER TRAIN

TRANSFER GEARS

21. Lower the temperature of bearing cup (21) and install it in cage (22).

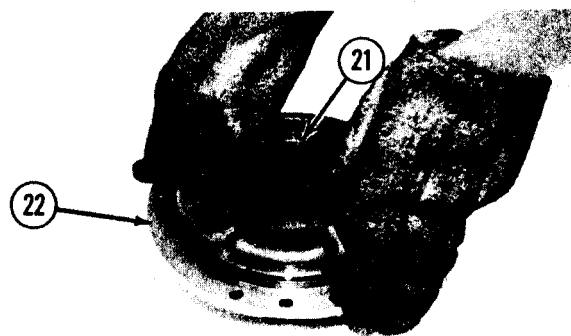

B49474X1

22. Install O-ring seal (23) on cage (22).

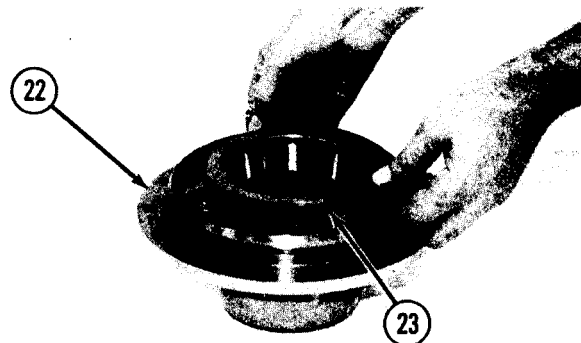

B49476X1

23. Put 7M7260 Liquid Gasket Material in the seal bore in cage (22) and let it dry, Do not put the liquid gasket material on the lip of the seal case. Use tooling (A) and install the seal in cage (22) with the lip of the seal toward the inside as shown. Put clean power train oil on the lip of the seal.

24. The bearing axis must be in a vertical position for the correct bearing adjustment.

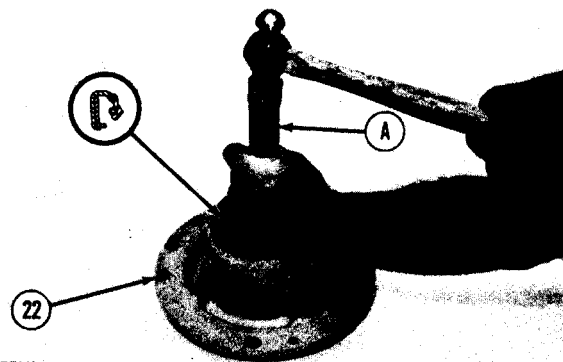

B49475X1

25. Install original shims (24) and cage (22) on the case.

26. Use tool (B) and a pry bar (25) to check bearing end play. Add or remove shims to get a bearing end play of 0.05 to 0.15 mm (.002 to .006 in.).

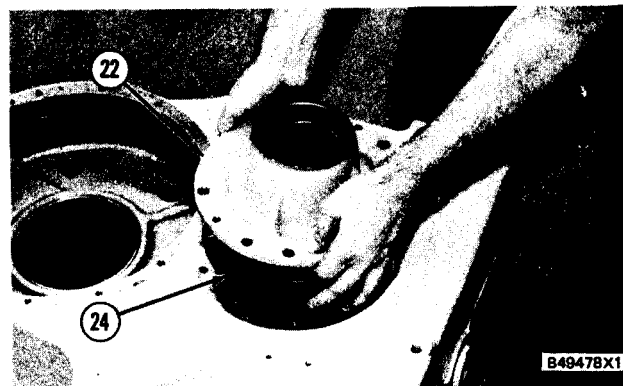
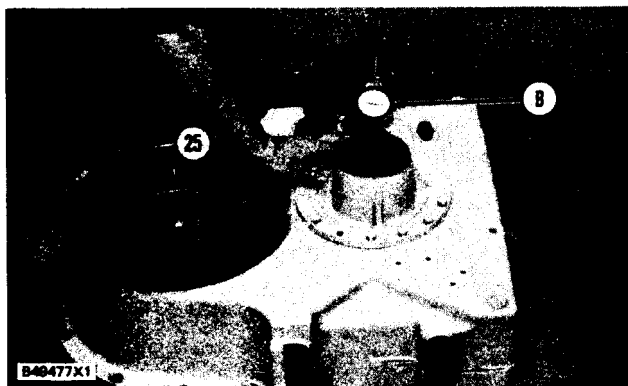

TRANSFER GEARS

27. Install yoke (26) on the output shaft.

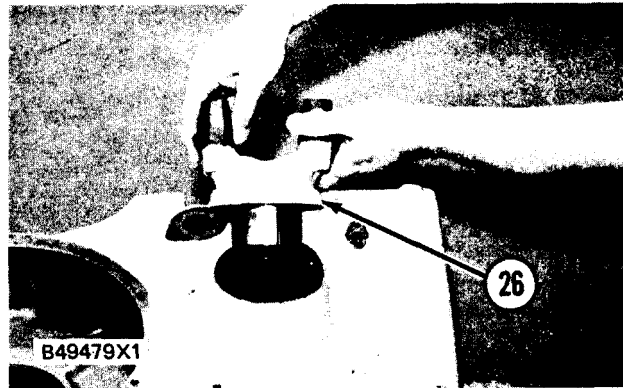

28. Put clean power train oil in the bore and on the O-ring seal. Install O-ring seal (29), spacer (28) and bolt (27) on the end of the output shaft. Tighten the bolt to a torque of 110 ± 10 N•m (80 ± 7 lb. ft.).

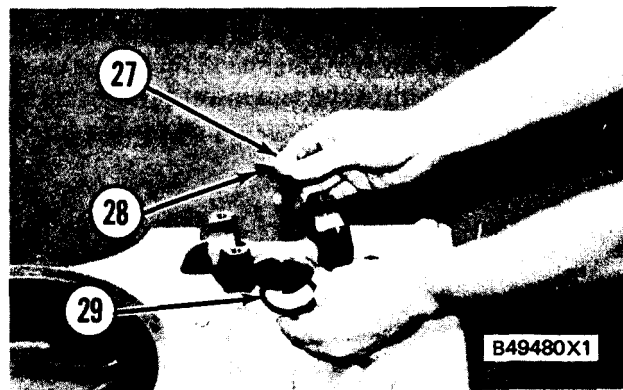

29. Lower the temperature of bearing cup (30) and install it in the case as shown.

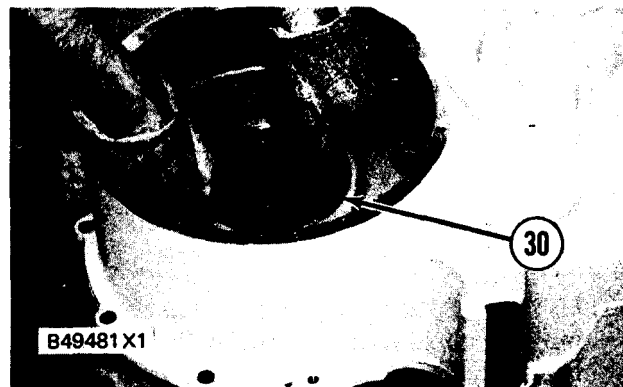

30. Heat bearing cones (31) to a maximum temperature of 135° C (275° F) and install them on each side of gear (32).

31. Install gear (32) in the case as shown.

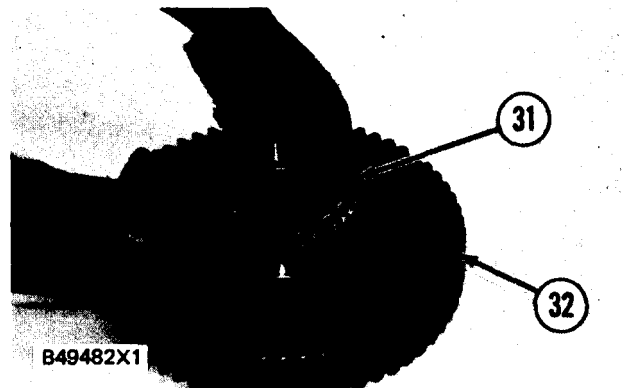
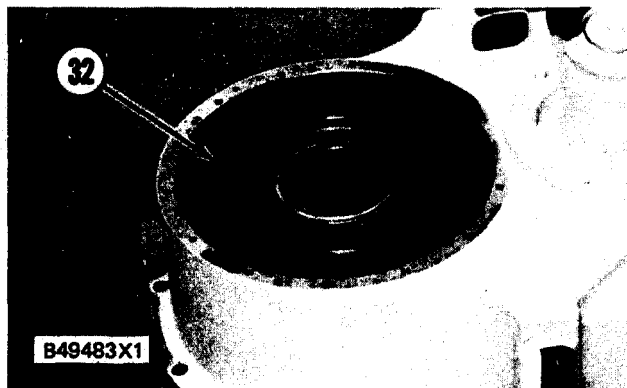

TRANSFER GEARS

32. Lower the temperature of bearing cup (34) and install it in cage (35).

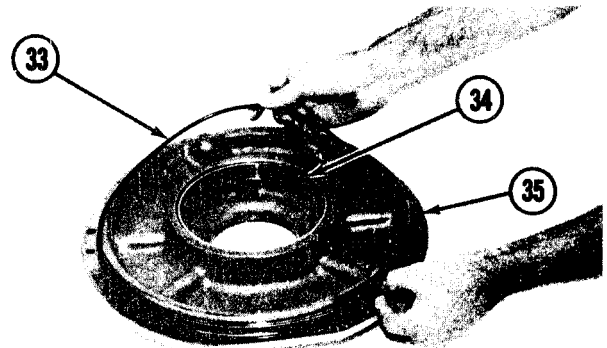

33. Put clean power train oil on O-ring seal (33) and install it on cage (35).

34. Install original shims (36) and cage (35) on the case as shown.

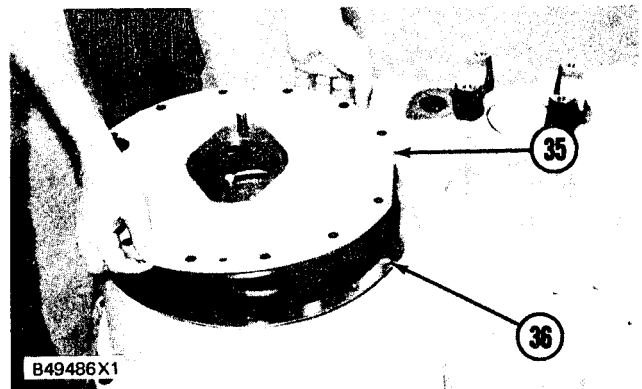

35. Use tool (B) and pry bar (25) to check bearing end play. Add or remove shims to get a bearing end play of 0.05 to 0.15 mm (.002 to .006 in.).

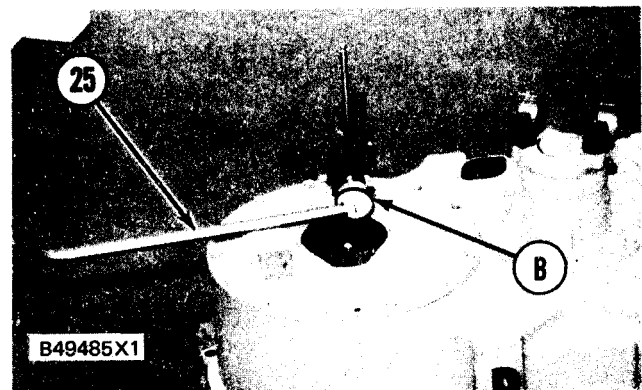

36. Install plate (37) on the cage as shown.

NOTE: Cover (39) is replaced with supplemental steering pump on some units.

37. Install gasket (38) and cover (39) on the cage as shown.

- end by:
- a) connection of transmission to transfer gears (see DISASSEMBLE TRANSMISSION)

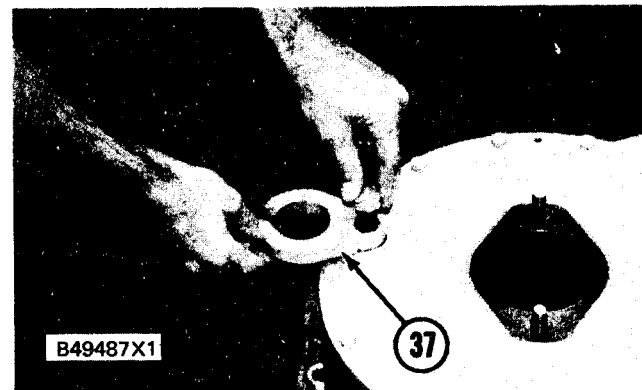
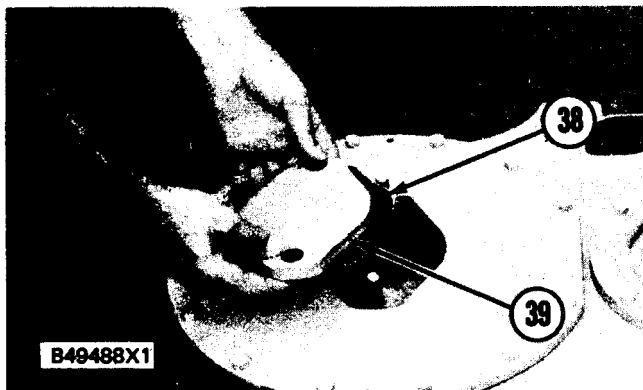

TILT LINK AND LEVER

REMOVE TILT LINK AND LEVER 6116 & 6117-11

Tools Needed		A	B
9S5558	Stud, 1 ¼ in.	1	
1P544	Nut	1	
4K684	Washer	1	
5P3100	Pump Group (or electric)	1	1
6V3175	Hydraulic Puller	1	
6V4035	Sleeve Assembly	1	
9S5556	Adapter		1
6H4158	Pin		2
7S7112	Pin		1
7M9774	Coupling		1
5P7371	Adapter		1
9S8900	Cylinder Group		1
7B2499	Ring		4
5P7370	Sleeve Assembly		1

1. Stop the machine with the bucket flat on the ground.
2. Remove bolt (1) that holds pin (2) to the bucket.
3. Put tooling (A) in position in the pin.
4. Fasten a hoist to tooling (A) so it will not fall when the pin is removed.
5. Fasten a hoist to the link assembly so it will not fall when the pin is removed.
6. Remove pin (2) from the bucket.
7. Fasten chain (3) to the tilt lever as shown to hold it in position.
8. Remove bolts (4) and put bucket positioner (5) on the loader frame.

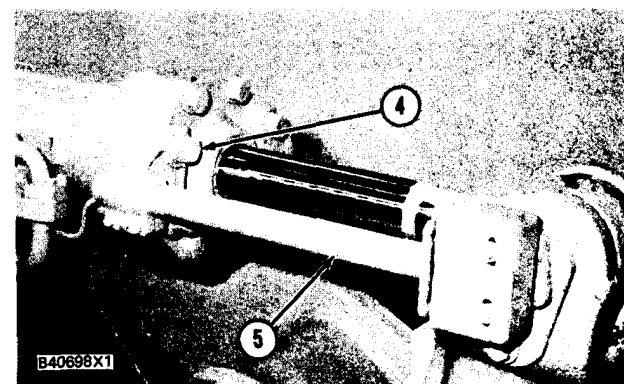
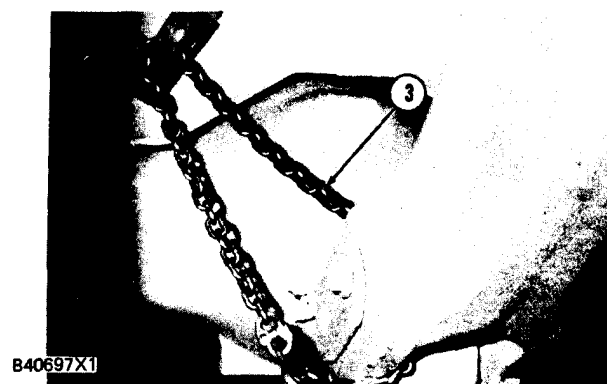
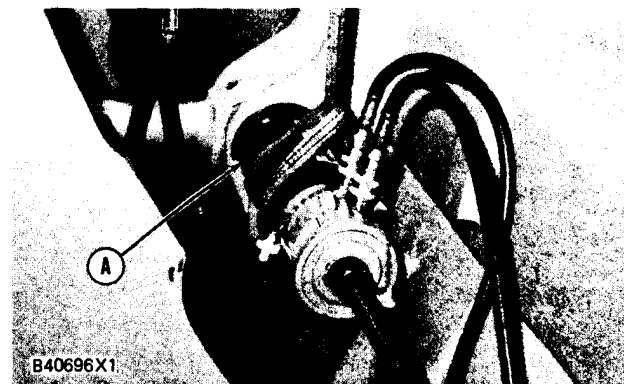
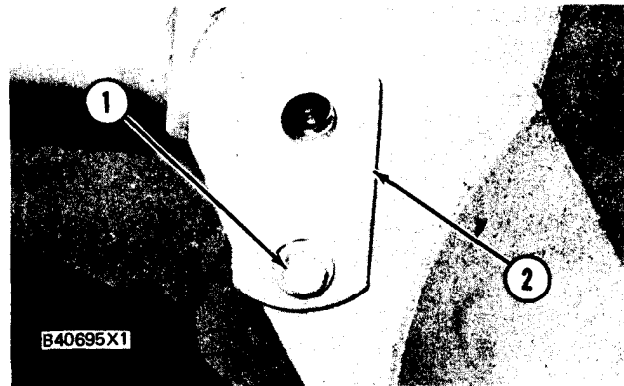

TILT LINK AND LEVER

9. Loosen setscrews (6) and remove magnet assembly (7) from the pin.

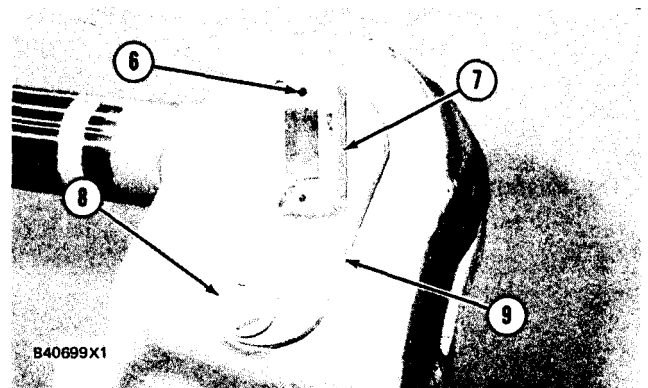

10. Remove bolt (8), the washer and spacer that hold pin (9) in place.

11. Put tooling (A) in position as shown. Fasten a hoist to tooling (A) and one to the tilt cylinder.

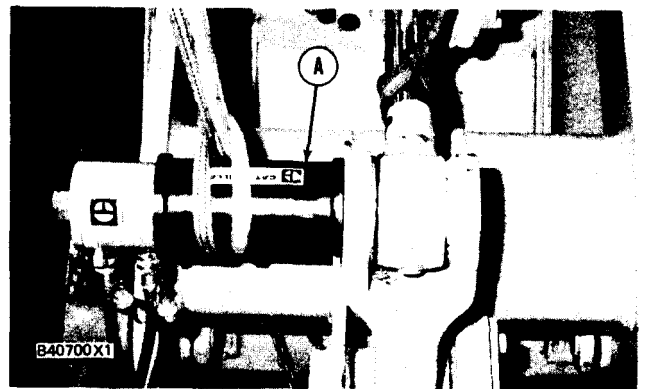

12. Remove the pin with tooling (A).

13. Move the cylinder rod into the cylinder with the machine hydraulics and lower the cylinder on to the loader frame.

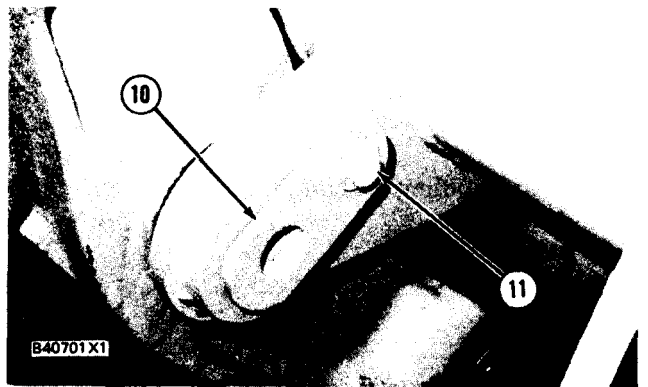

14. Remove bolt (11), the washer and spacer that holds pin (10) in place.

15. Fasten a hoist to the lever assembly.

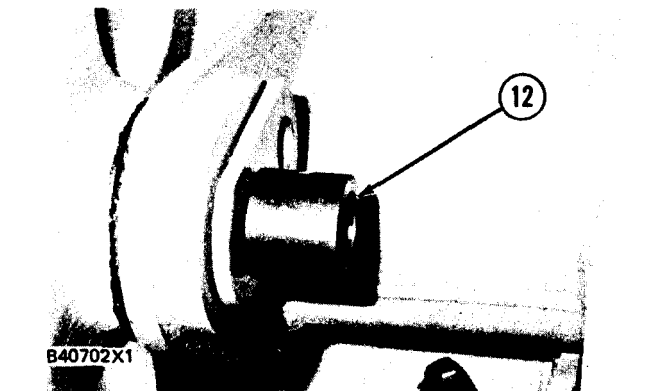

16. Put adapter (12) of tooling (B) in the pin.

TILT LINK AND LEVER

17. Install tooling (B) on the pin as shown.

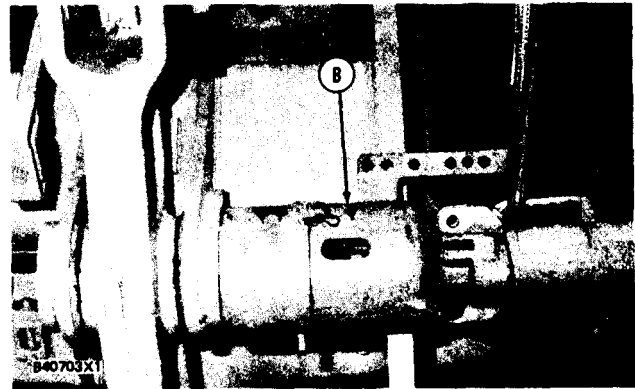

18. Fasten a hoist to tooling (B) so the tooling will not fall when the pin is removed.

19. Remove the pin with tooling (B). The weight of the pin is 34 kg (75 lb.).

20. Remove the lever and link assembly. The weight of the lever and link assembly is 338 kg (740 lb.).

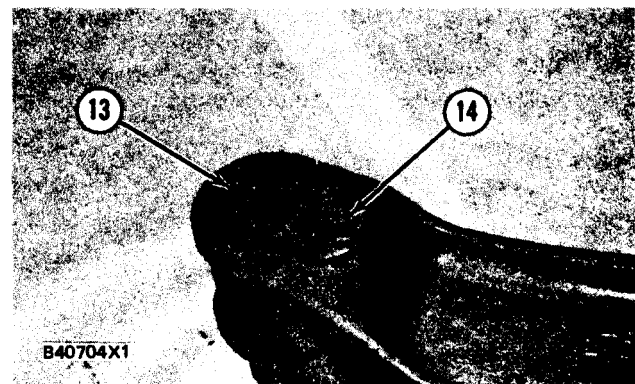

21. Remove bolt (14), the washer and spacer that holds pin (13) in place.

22. Install tooling (A) on pin (13) and remove the pin.

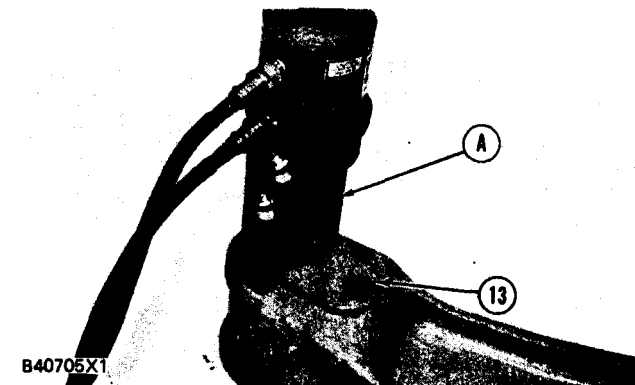

23. Remove the link from the lever,

24. Remove lip type seals (15) from both sides and each end of link (17).

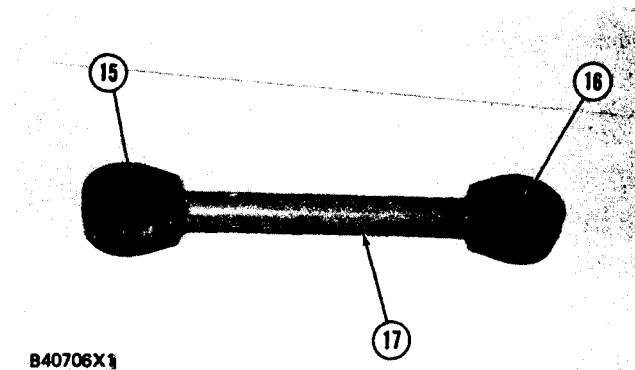

25. Remove bearings (16) from each end of link (17).

TILT LINK AND LEVER

26. Remove lip type seals (18) from each side of the lever.

27. Remove bearing (19) from the lever.

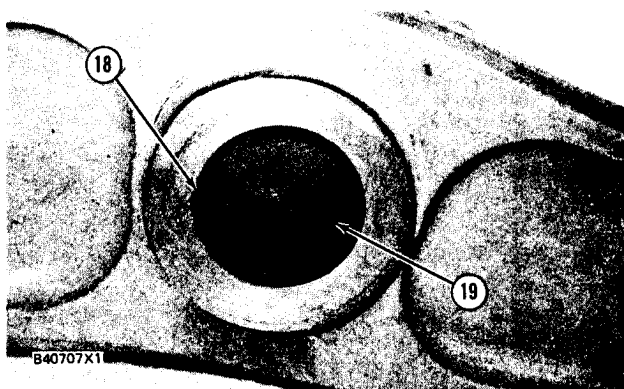

INSTALL TILT LINK AND LEVER 6116,6117-12

Tools Needed		A	B	C
9S5558	Stud, 1 1/4 in.	1	1	
1P544	Nut	1	1	
4K684	Washer	1	1	
5P3100	Pump Group (or electric)	1	1	
6V3175	Hydraulic Puller	1	1	
1P1842	Plate	1		
9S5431	Sleeve Assembly	1		
1P1838	Plate		1	
6V4035	Sleeve Assembly		1	
1P520	Driver Group			1

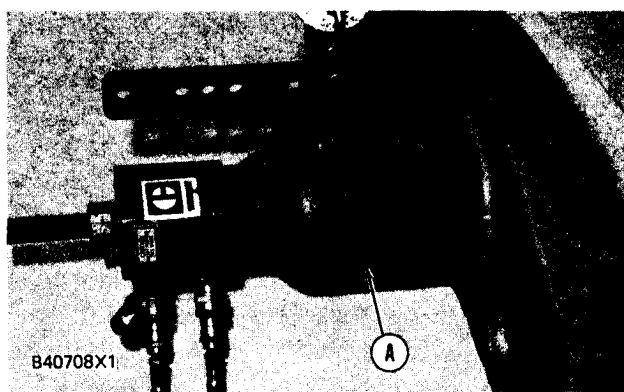

1. Lower the temperature of the bearing and install it in the lever with tooling (A).

2. The bearing must be installed in the center of the bore with the same amount of space on each side.

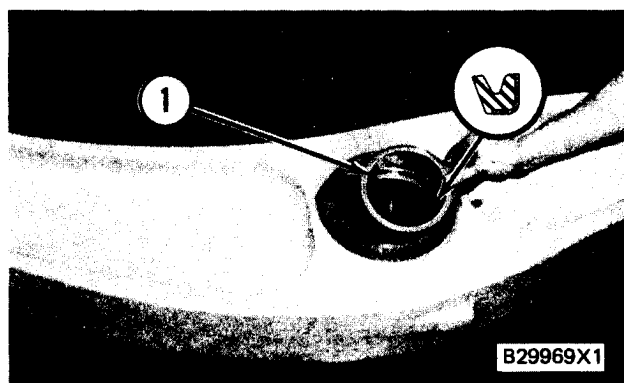

3. Install two lip type seals (1) in the lever. The lip of the seal must be toward the outside as shown.

4. Lower the temperature of the bearings and install them in the center of the bores with the same amount of space on each side with tooling (B).

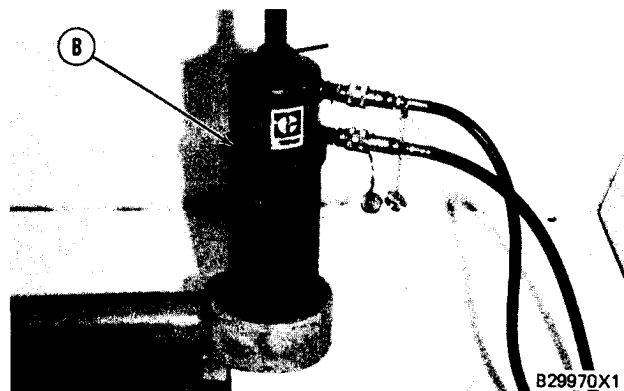

TILT LINK AND LEVER

5. Install the lip type seals in the link with tooling (C). The lip of the seal must be toward the outside.

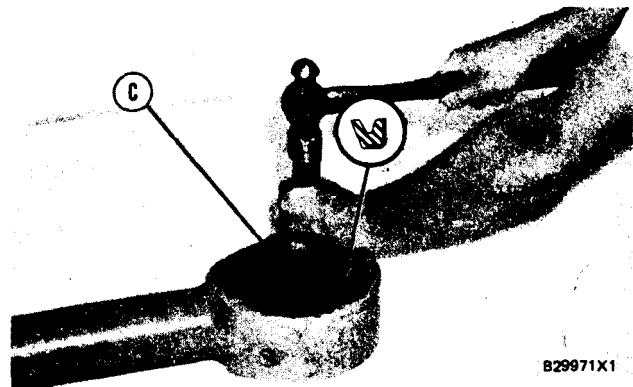

6. Put 5P960 Multipurpose Type Grease in the bores of the link, lever, tilt cylinder and the bucket.

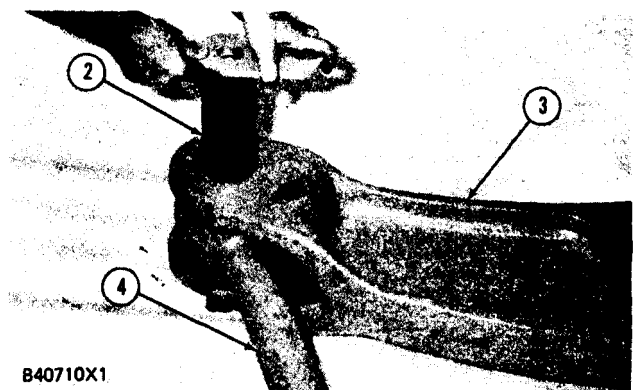

7. Put link (4) in place in lever (3) and install pin (2).

8. Install spacer (6), the washer and bolt (5) that holds pin (2) in place.

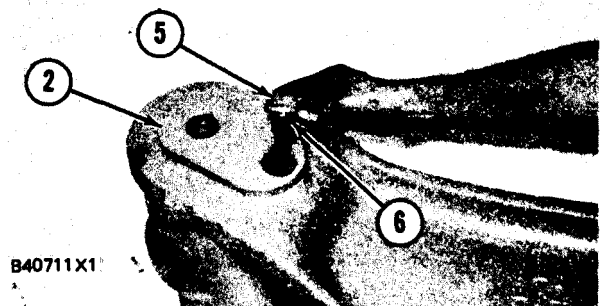

9. Fasten a hoist to the link and lever assembly and put it in position on the machine.

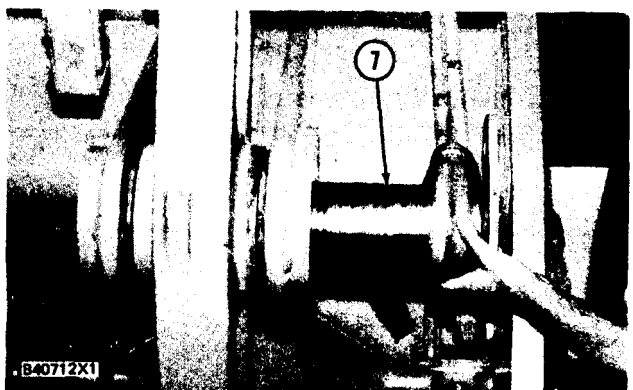

10. Fasten a hoist to pin (7) and install pin (7) in the lever assembly.

TILT LINK AND LEVER

11. Install spacer (8), the washer and bolt (9) that holds the pin in place.
12. Fasten a hoist to the link and put it in position on the bucket.
13. Install pin (10) that connects the link to the bucket.
14. Install the spacer, washer and the bolt that holds the pin in place.
15. Fasten a hoist to the tilt cylinder and put into position on the lever assembly.
16. Install pin (11) that connects the tilt cylinder and lever assembly.
17. Install the spacer, washer and bolt (13) that holds the pin in place.
18. Install magnet (12) and tighten the two set-screws that hold the magnet assembly in place.
19. Put the bracket Positioner (14) in position on the machine and install the bolts that hold it.

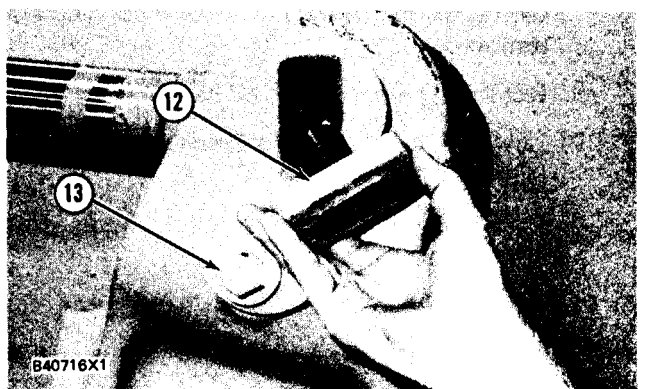
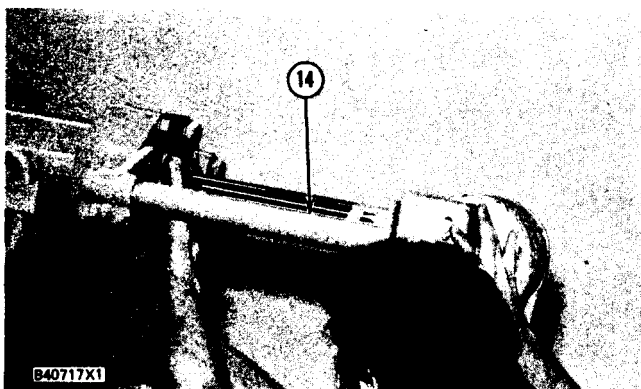
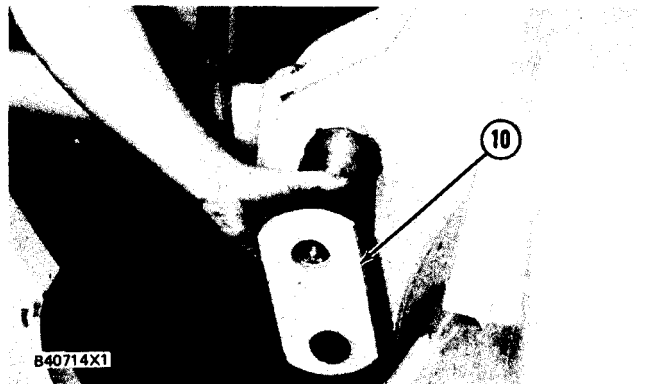
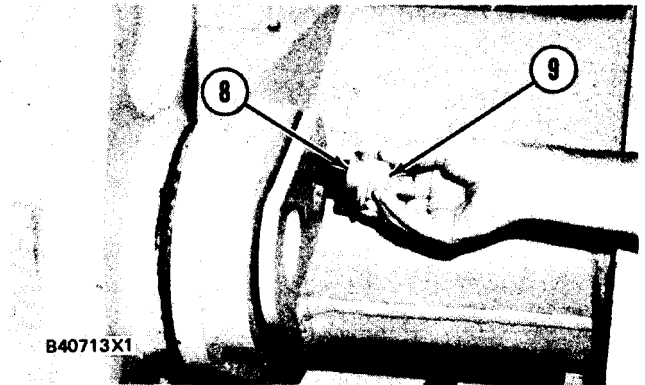

LOADER FRAME

REMOVE LOADER FRAME

7054-11

Tools Needed	A	B	C
8S7615 Pin	2		
8S8048 Saddle	2		
8S7641 Tube	2		
8S7630 Stand	2		
9S5558 Stud 1 ¼ in.		1	1
1P544 Nut		1	1
4K684 Washer		1	1
6V3175 Hydraulic Puller		1	1
5P3100 Pump Group (or electric)		1	1
6V86 Adapter		1	
5H6797 Pin			1
8S6377 Lock			1
9S5433 Adapter			1
9S5431 Sleeve Assembly			1
5P9736 Link Bracket			1

start by:

- a) remove bucket
- b) remove tilt link and lever
- c) remove tilt cylinder

1. Put caps on the tilt cylinder oil lines.
2. Use the machine hydraulics and lift the loader frame until the front and rear pin bores are level.
3. Install tooling (A) as shown under the loader frame.
4. Remove grease fitting (2) from the pin.
5. Remove bolt (1), the washer and spacer from the pin.
6. Fasten a hoist to the lift cylinder.
7. Install tooling (C) on the pin. Fasten a hoist to tooling (C) so it does not fall when the pin is removed.
8. Remove the pin from the loader frame.
9. Lower the lift cylinder down on to the main frame.
10. Do Steps 3 through 9 for the cylinder on the other side of the machine.
11. Retract the cylinders as far as possible.
12. Fasten straps (3) and a hoist to loader frame (4) as shown.

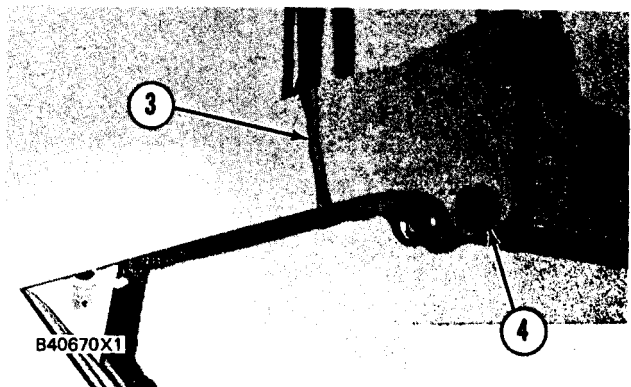
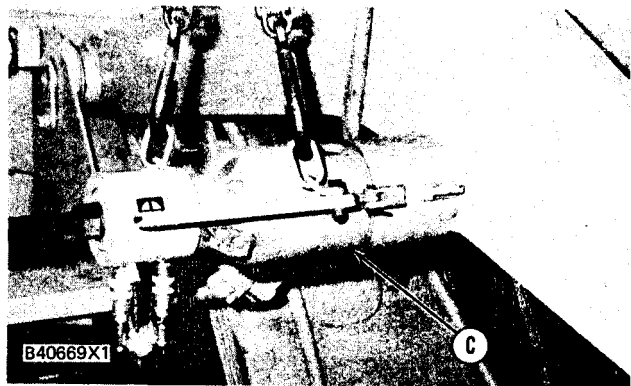
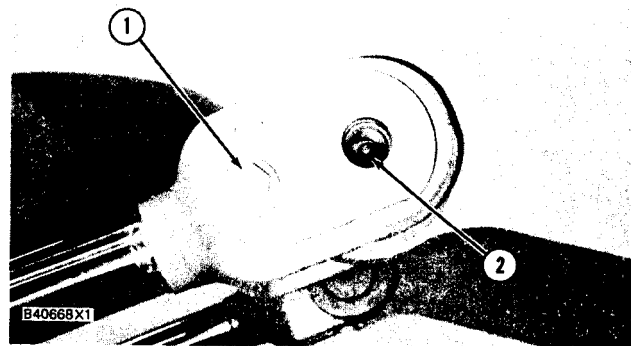
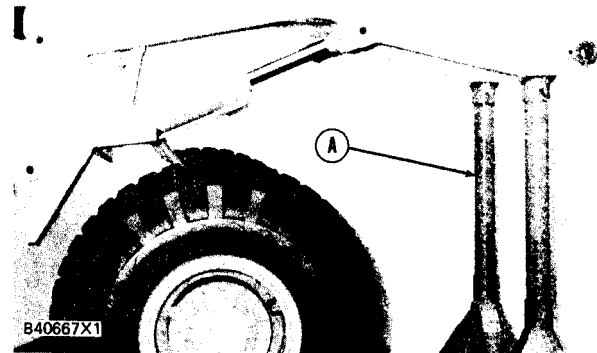

LOADER FRAME

13. Loosen screw (5) and disconnect the wire from bracket and light assembly (6).

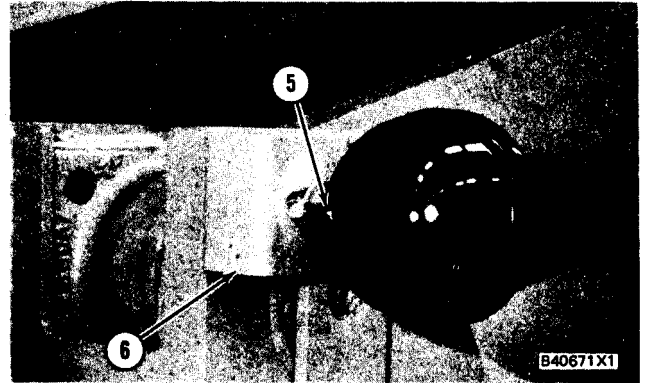

14. Remove the nuts and remove bracket and light assembly (6).

15. Remove grease fitting (7) from pin (8).

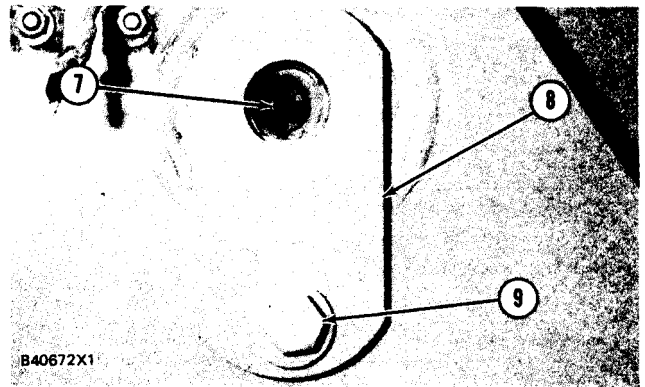

16. Remove bolt (9), the washer and spacer from pin (8).

17. Install tooling (B) on the pin. Fasten a hoist to tooling (B) so it does not fall when the pin is removed.

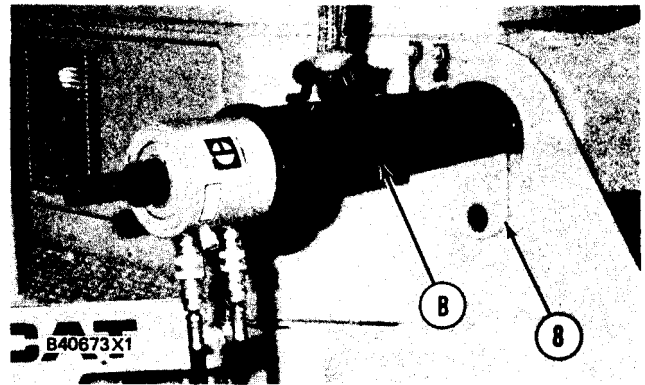

18. Remove pin (8) with tooling (B).

19. Do Steps 13 through 18 for removal of the bracket and light assembly and pin from the other side of the machine.

20. Remove the loader frame. The weight of the loader frame is 955 kg (2100 lb.).

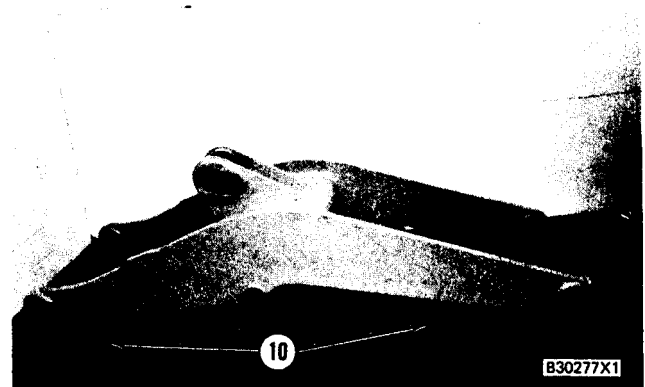

21. Put the loader frame on blocks (10) so access to the pin bores is possible when assembly takes place.

LOADER FRAME

22. Remove lip type seals (11) from the bores in the loader frame.

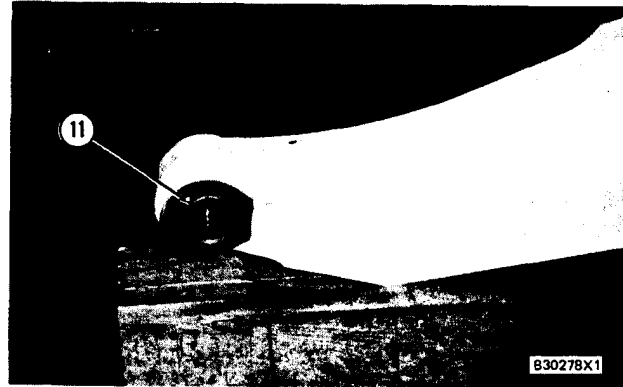

23. Remove bearing (12) from the frame.

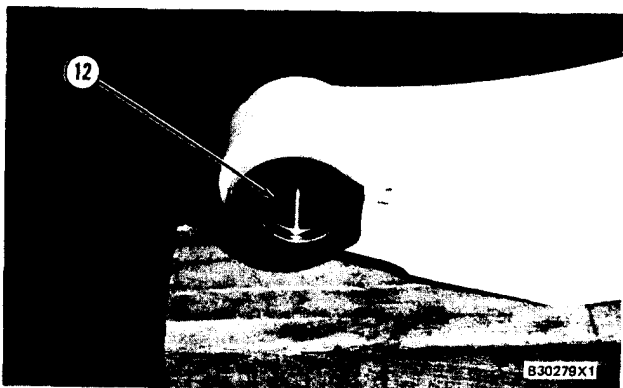

INSTALL LOADER FRAME

7054-12

Tools Needed	A	B	C	D	E
9S5558 Stud, 1 ¼ in.	1	1	1		
1P544 Nut	1	1	1		
4K684 Washer	1	1	1		
5P3100 Pump Group (or electric)	1	1	1		
6V3175 Hydraulic Puller	1	1	1		
1P1835 Plate	1				
1P1837 Plate		1			
1P1839 Plate			1		
1P520 Driver Group				1	
8S7641 Tube					2
8S7630 Stand					2
8S8048 Saddle					2
8S7615 Pin					2

1. Lower the temperature of all the bearings before they are installed in the loader frame.

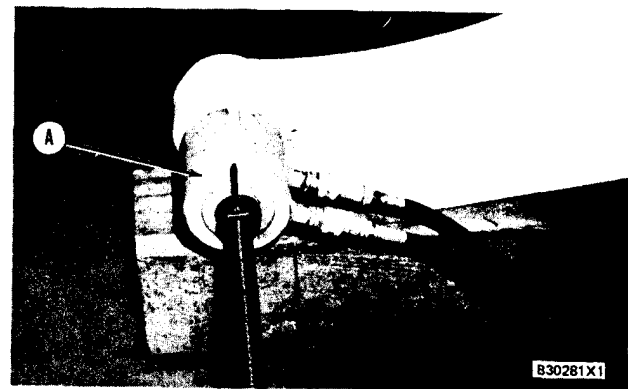

2. Use tooling (A) to install the bearings in the bucket pin bores. The bearings must be installed in the center of the bores.

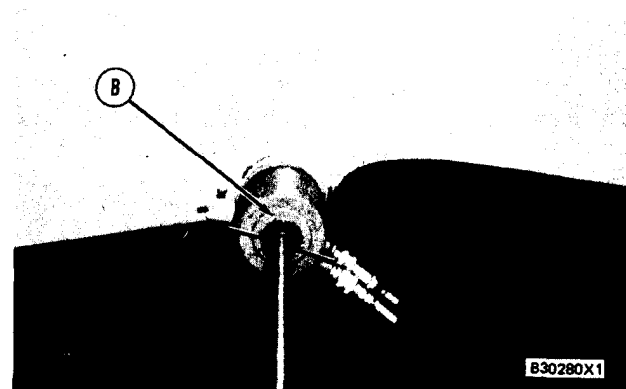

3. Install the bearings in the center of the lift cylinder pin bores with tooling (B).

LOADER FRAME

- Use tooling (C) to install the rear bearings in the center of the bores.

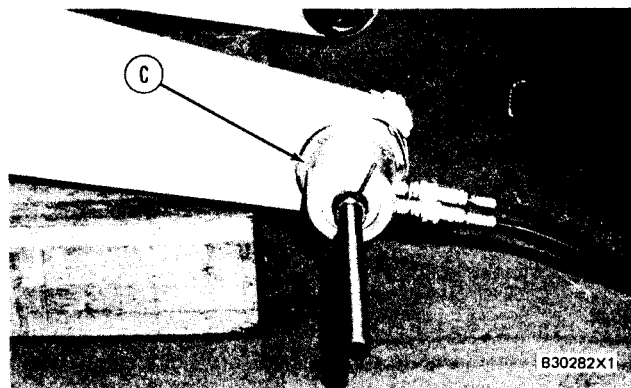

- Use tooling (D) to install the lip type seals in the bores. Seals must be installed with lip of the seals toward the outside of the bore.

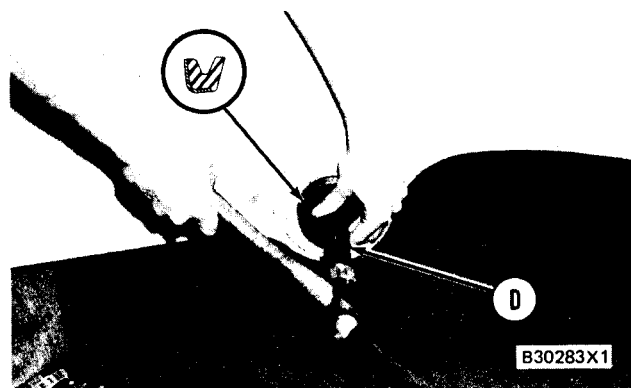

- Put 5P960 Multipurpose Type Grease in all the pin bores of the loader frame.

- Put tooling (E) and loader frame (1) in position.

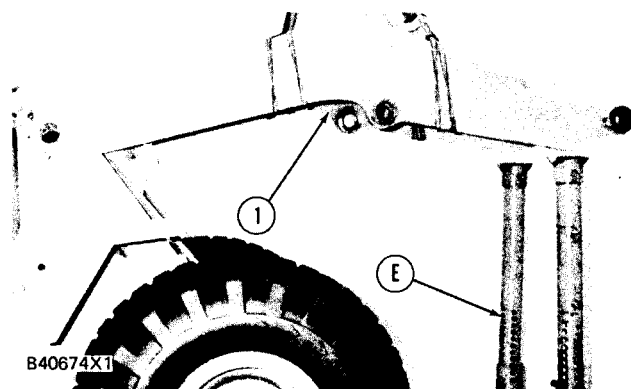

- Install rear pins (2) in the machine and the loader frame.

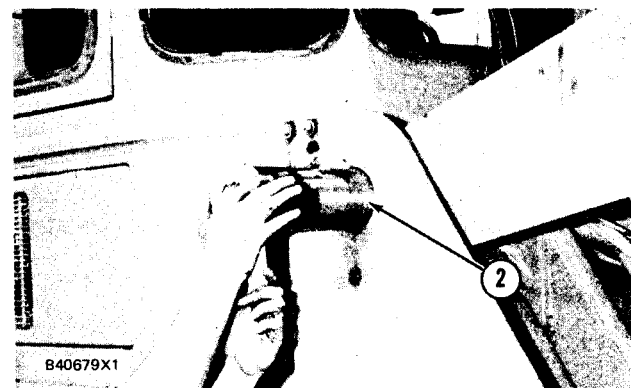

- Install the grease fittings in pins (2).

LOADER FRAME

10. Install spacers (5), washers (4) and bolts (3) that hold the pins in place.

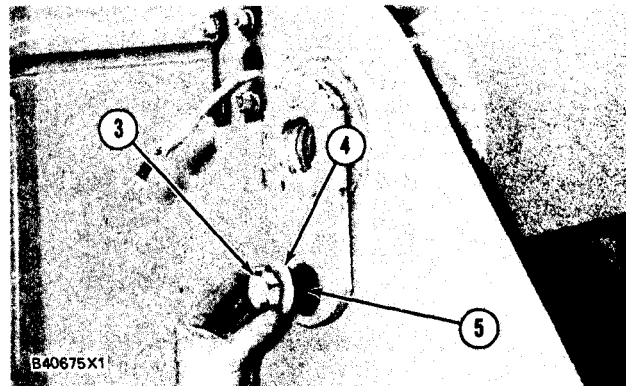

11. Install bracket and light assemblies (6) on both sides of the machine and connect the wires.

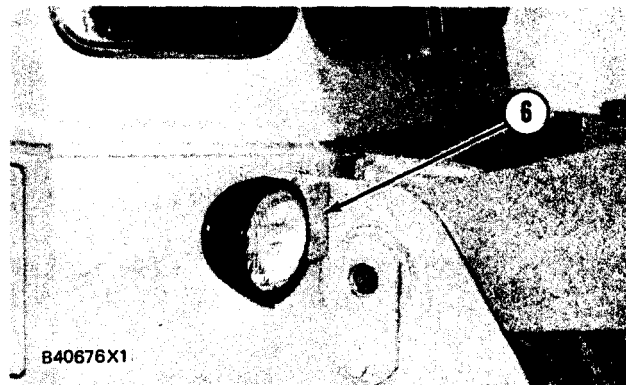

12. Fasten a hoist to the lift cylinders. Lift the cylinders into position and install pins (7).

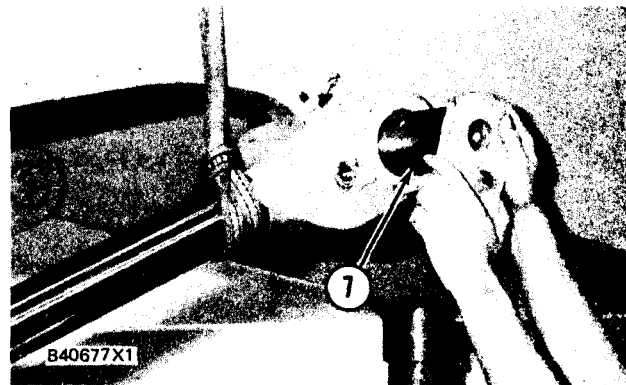

13. Install the spacers, washers and bolts (8) that hold the pins in place.

14. Install grease fittings (9) in both pins (7).

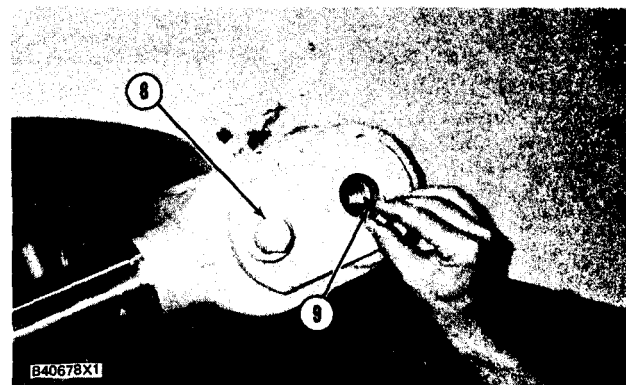

15. Fill the lift cylinders and rear bores with 5P960 Multipurpose Type Grease.
end by:
a) install bucket
b) install tilt link and lever
c) install tilt cylinder

LIFT KICKOUT CONTROL**REMOVE LIFT KICKOUT CONTROL 5109-11**

1. Remove two bolts (1) and magnet assembly (2) from the lift arms.
2. Disconnect wire (4).
3. Remove bolts (5) and holder assembly (3) from the front main frame.
4. Remove two bolts (6) and switch assembly (7) from the holder.

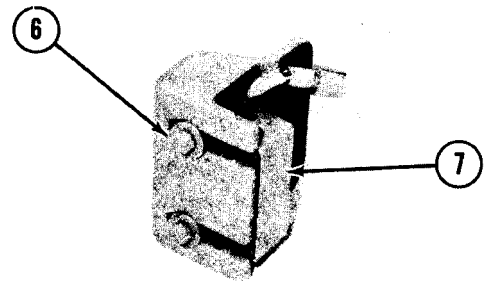
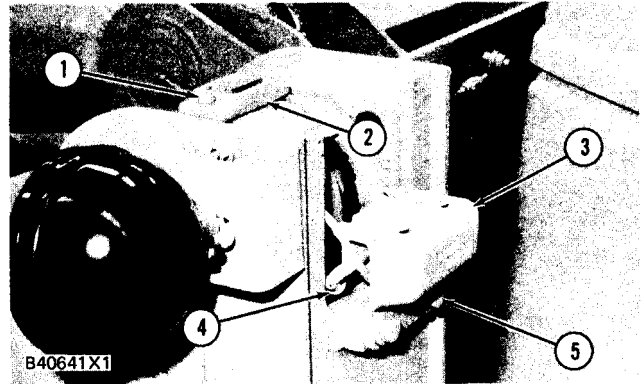
**INSTALL LIFT KICKOUT CONTROL 5109-12**

1. Put switch assembly (2) in position in holder (1). Install bolts (3) that hold the switch in place.
2. Put holder assembly in position and install bolts (7).
3. Connect wires (6).
4. Put magnet assembly (4) in position and install bolts (5).
5. Make an adjustment to the lift kickout. See TESTING AND ADJUSTING.

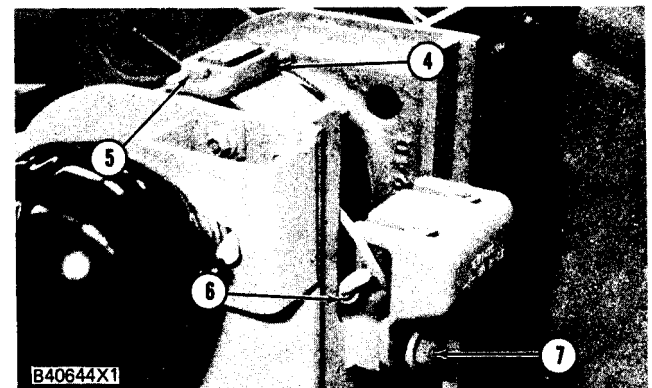
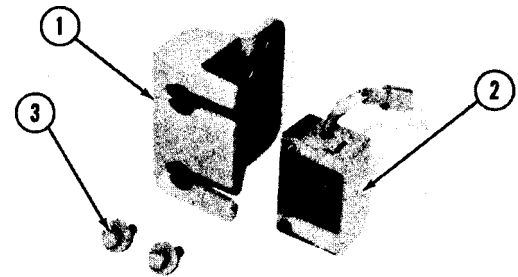

BUCKET POSITIONER CONTROL

REMOVE BUCKET POSITIONER CONTROL

5112-11

1. Remove bolts (1) and disconnect cover (2) from the tube assembly.

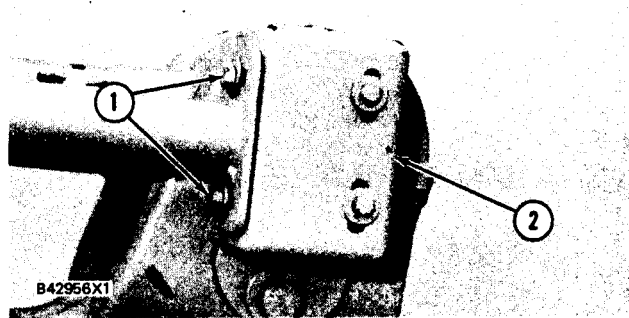

2. Remove clip (3) and disconnect wires (5).

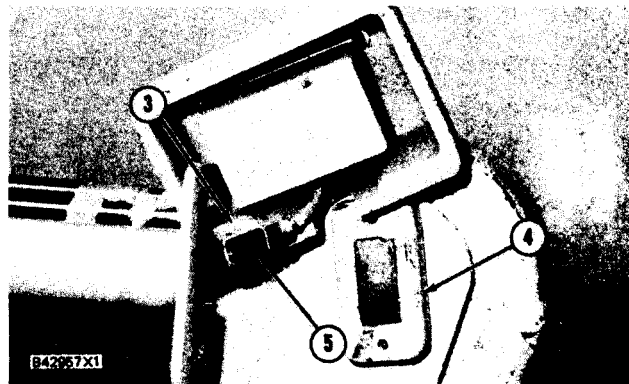

3. Remove cover (2) from the machine.

4. Loosen the two setscrews and remove magnet assembly (4) from the pin.

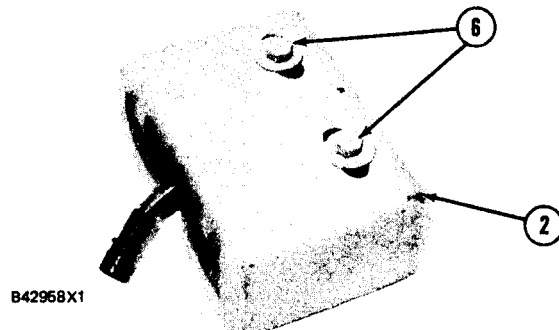

5. Remove bolts (6) that hold the block and the magnet assembly to cover (2).

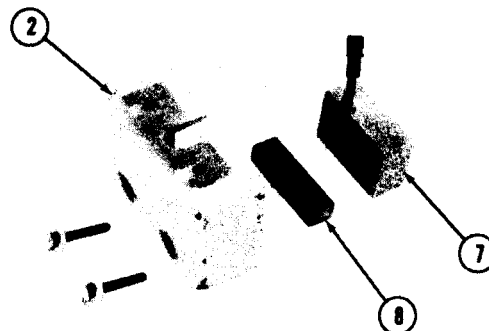

6. Remove magnet assembly (7) and block (8) from cover (2).

BUCKET POSITIONER CONTROL**INSTALL BUCKET POSITIONER CONTROL**

5112-12

1. Install block (3) and magnet assembly (4) in cover (2) with bolts (1).

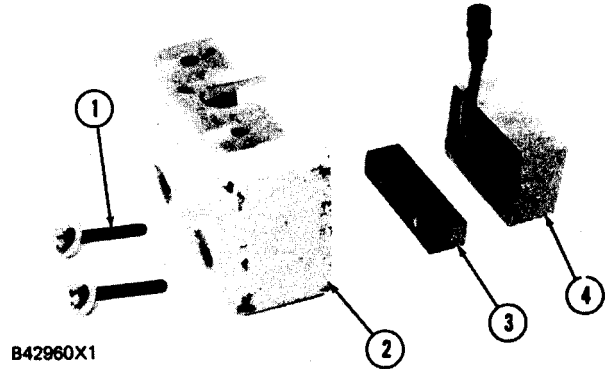

2. Connect wires (5).

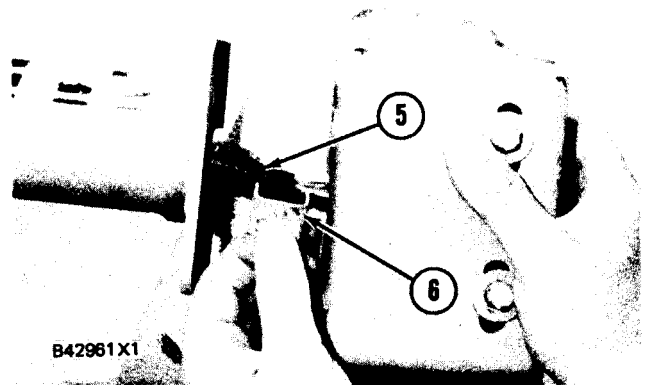

3. Install clip (6) that holds wires (5) together.

4. Install magnet assembly (7) in the pin and tighten the two setscrews.

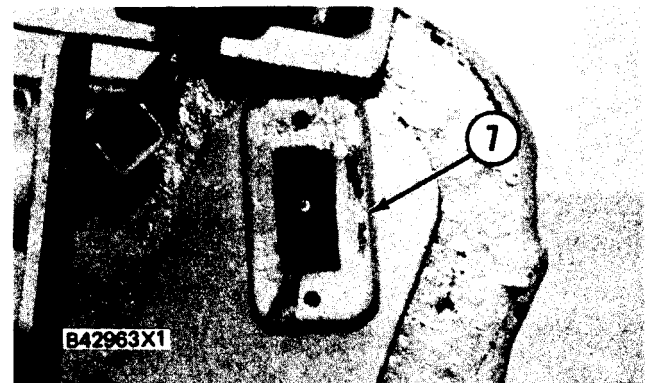

5. Put cover (2) in position on the tube assembly and install bolts (8).

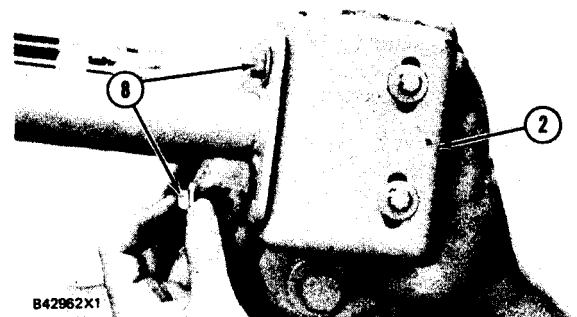

6. Make an adjustment to the bucket positioner. See TESTING AND ADJUSTING.

SEQUENCE VALVE

REMOVE AND INSTALL SEQUENCE VALVE

1. Remove nuts (1) and cover (2) from the machine.

WARNING

To prevent personal injury, release the pressure from the hydraulic system before any lines are removed or disconnected.

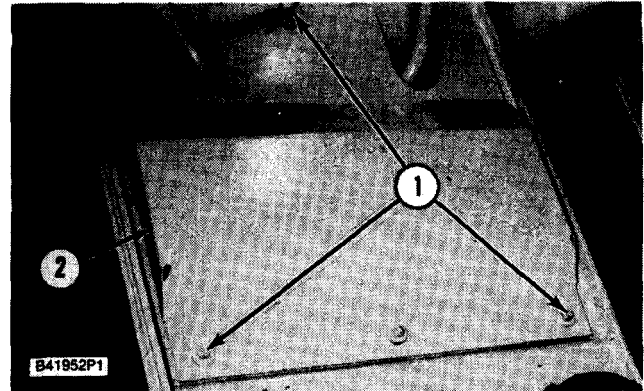

2. Place identification labels on all hose and tube assemblies that are removed.
3. Disconnect tube assembly (3) at elbow (4).
4. Disconnect tube assembly (5) from sequence valve (6).
5. Disconnect tube assembly (7) from sequence valve,
6. Remove two bolts and washers (8).
7. Disconnect sequence valve (6) at tee (9),
8. Remove elbow (4) from sequence valve,
9. To install sequence valve (6), connect valve at tee (6).
10. Install two bolts and washers (8).
11. Connect tube assembly (7) to sequence valve.
12. Connect tube assembly (5) to sequence valve,
13. Connect elbow (4) and tube assembly (3) to sequence valve.
14. Start the engine and operate the attachment (third) control lever. Check for leakage of hydraulic fluid from fittings. If there is no leakage, install cover (2) and nuts (1).

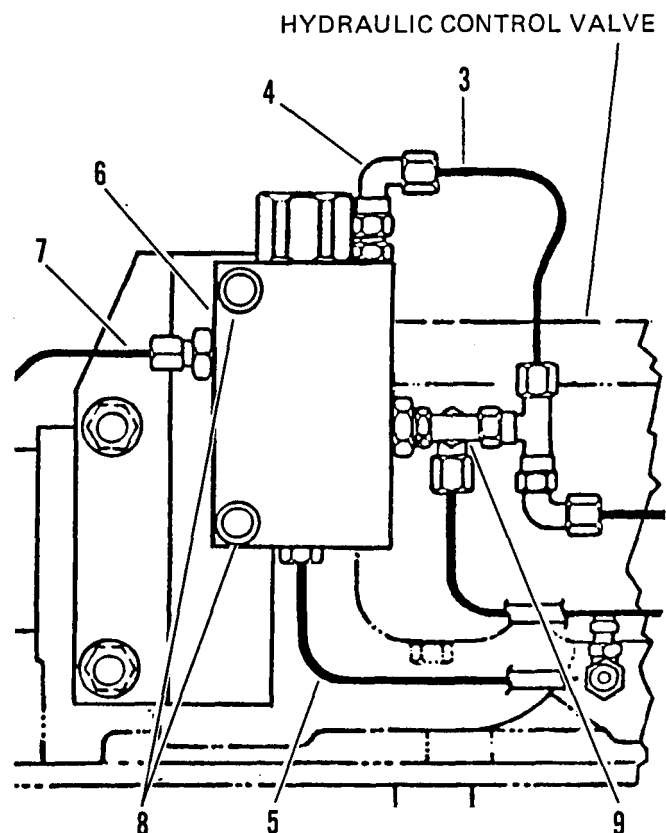

SEQUENCE VALVE

DISASSEMBLE AND ASSEMBLE SEQUENCE VALVE

1. Remove relief valve (1) from sequence valve body (2).
2. Remove seal (3) from relief valve.
3. Remove seal (4) and ring (5) from relief valve.
4. Remove cap (6) from sequence valve body (2).
5. Remove seal (7) from cap.

NOTE: The remaining sequence valve components are not repairable.

6. To assemble sequence valve, place seal (7) on cap (6) and install cap in sequence valve body (2).
7. Install seal (3), seal (4), and ring (5) on relief valve (1).
8. Install relief valve (1) in sequence valve body (2).

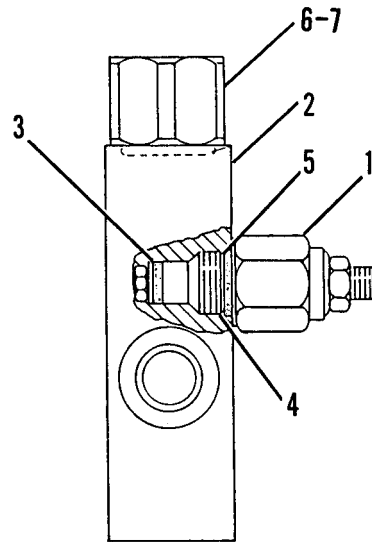

SHUTTLE VALVE

REMOVE AND INSTALL SHUTTLE VALVE

1. Remove nuts (1) and cover (2) from the machine.

WARNING

To prevent personal injury, release the pressure from the hydraulic system before any lines are removed or discarded.

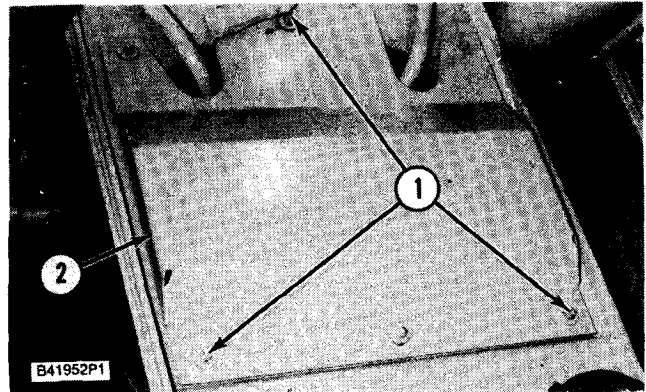

2. Place identification labels on all hose and tube assemblies that are removed.
3. Disconnect hose assembly (3) from tee (4).
4. Disconnect tube assembly (5) from other side of tee (4).
5. Disconnect tube assembly (6) from elbow (7).
6. Unscrew shuttle valve (8) from coupling on hydraulic control valve (9).
7. Remove tee (4) and elbow (7) from valve (8).
8. To install shuttle valve (8), screw valve onto coupling on the hydraulic control valve (9).
9. Install tee (4) and elbow (7).
10. Connect tube assembly (6) at elbow (7).
11. Connect tube assembly (5) to tee (4).
12. Connect hose assembly (3) to tee (4).
13. Start the engine and operate the attachment (third) control lever. Check for leakage of hydraulic fluid from fittings. If there is no leakage, install cover (2) and nuts (1).

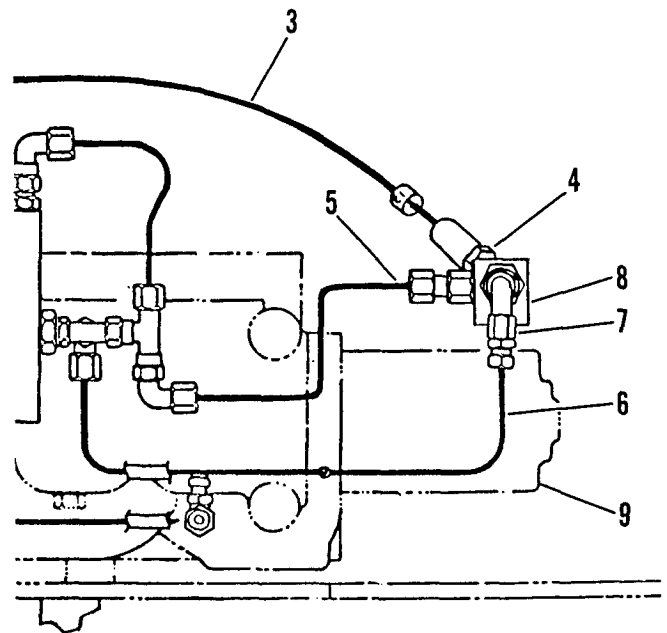

BUCKET POSITIONER CONTROL

INSTALL BUCKET POSITIONER CONTROL

5112-12

1. Install block (3) and magnet assembly (4) in cover (2) with bolts (1).

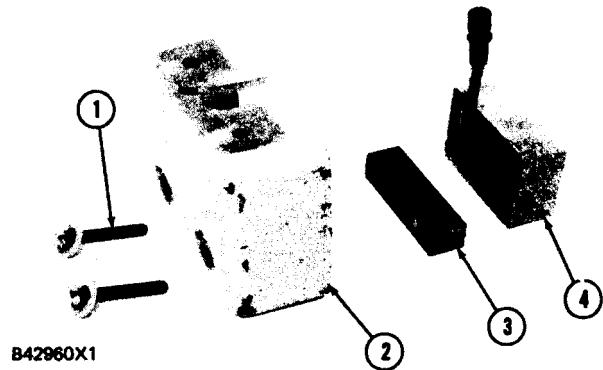

2. Connect wires (5).

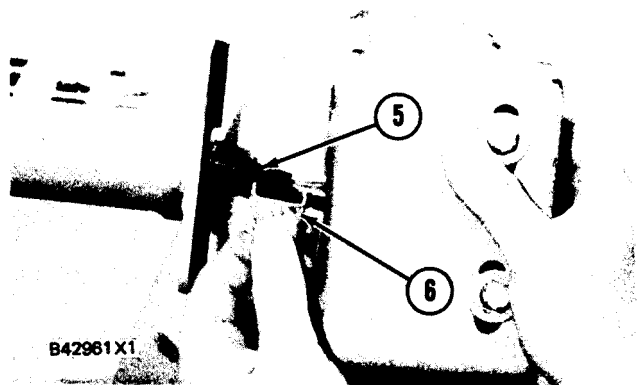

3. Install clip (6) that holds wires (5) together.

4. Install magnet assembly (7) in the pin and tighten the two setscrews.

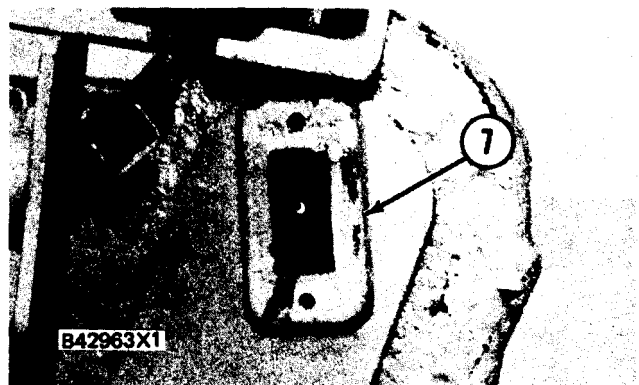

5. Put cover (2) in position on the tube assembly and install bolts (8).

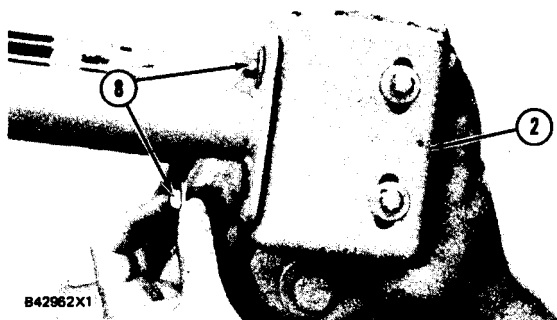

6. Make an adjustment to the bucket positioner.
See TESTING AND ADJUSTING.

LOADER CONTROL VALVES

7. Remove bolts (9) and disconnect hose assembly (8) from the control valves.

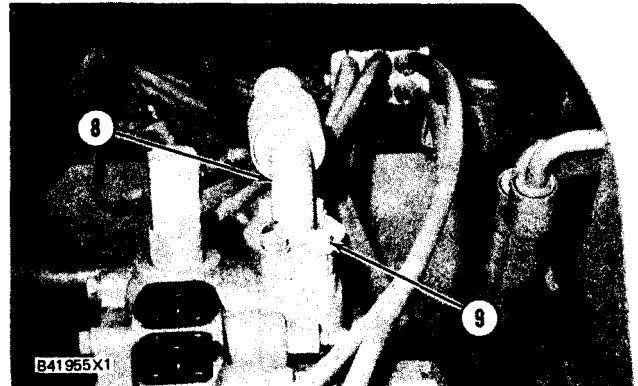

8. Remove bolts (10) and disconnect tube assemblies (11) from the control valves.

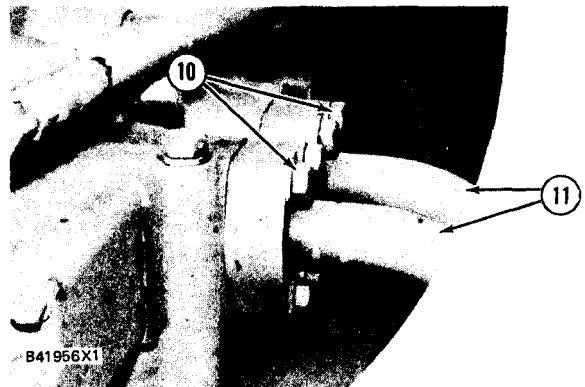

9. Disconnect hose assemblies (12) and (13) from the control valves.

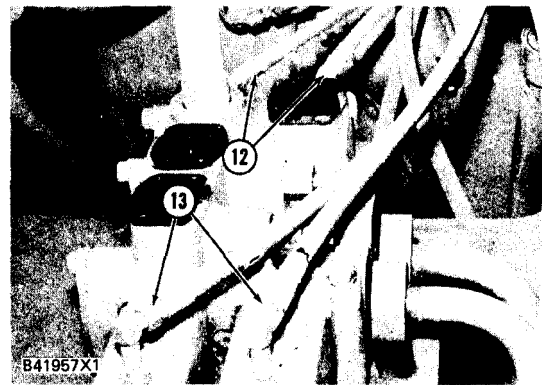

10. Disconnect hose assembly (14) from the bottom of the control valves.

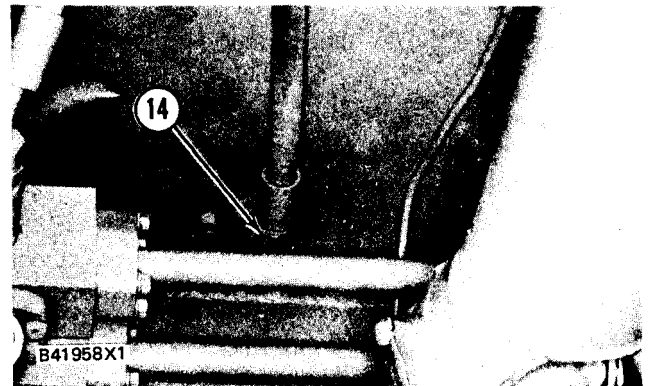

11. Remove three bolts that hold loader control valves (15) to the machine. Install 3/8"- 16 NC forged eyebolt and a 1/2"-13 NC forged eyebolt in the valves as shown. Fasten a hoist to the eyebolts and remove valve (15) as shown. The weight of the valves is 54 kg (120 lb.).

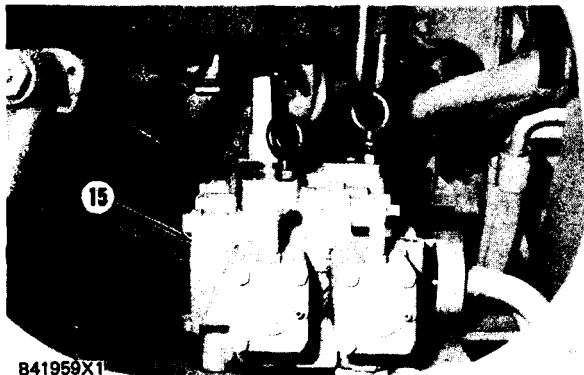

LOADER CONTROL VALVES

INSTALL LOADER CONTROL VALVES 5051-12

Tools Needed		A
8S7641	Tube	2
8S7630	Stand	2
8S8048	Saddle	2
8S7615	Pin	2

1. Install a 1/2"- 13 NC forged eyebolt and a 3/8"- 16 NC forged eyebolt in loader control valves (1) as shown. Fasten a hoist to the valves.

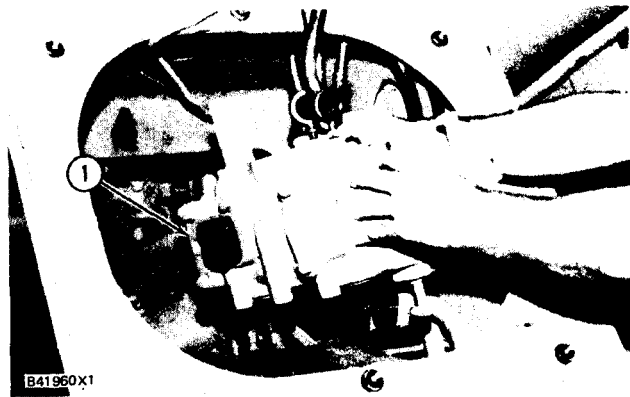

2. Put the valves in position and install the bolts that hold the valves to the machine.

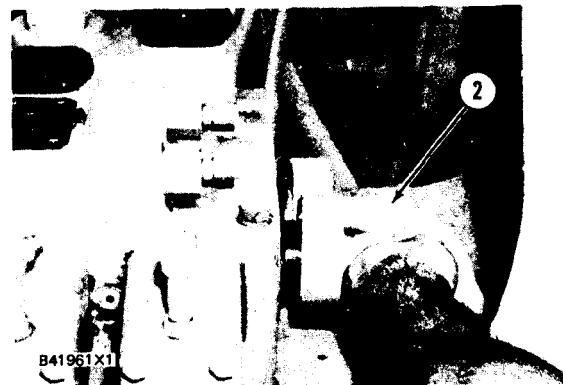

3. Inspect all O-ring seals for wear or damage. Make replacements if necessary.

4. Put the O-ring seals in position in tube assemblies (2). Install the flanges and bolts.

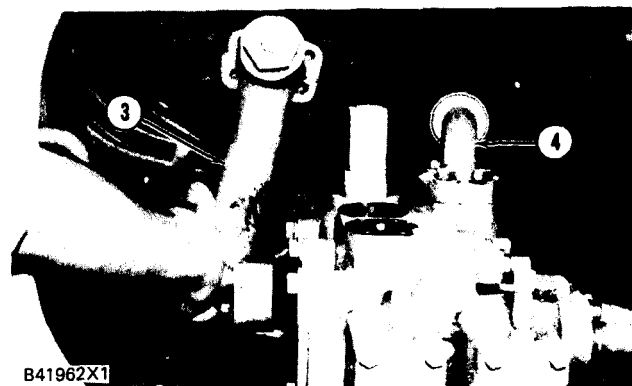

5. Connect hose assembly (4) and manifold (3) to the control valves.

6. Connect tube assemblies (5) to the control valves.

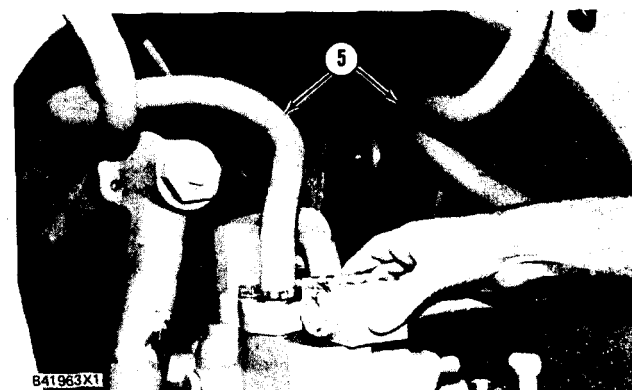

7. Connect the top of the tube assemblies to the brackets on the machine.

LOADER CONTROL VALVES

- 8 Connect four hose assemblies (6) to the control valves.

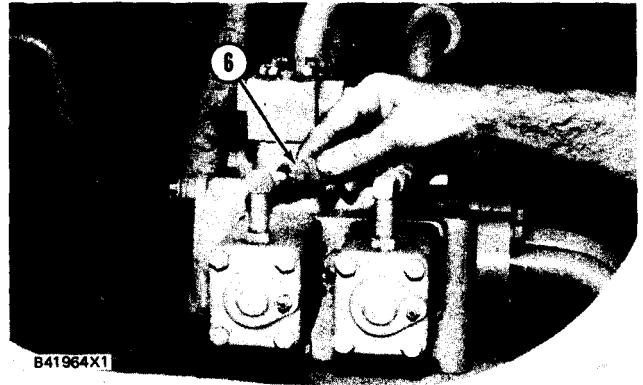

9. Connect hose assembly (7) to the bottom of the control valves.

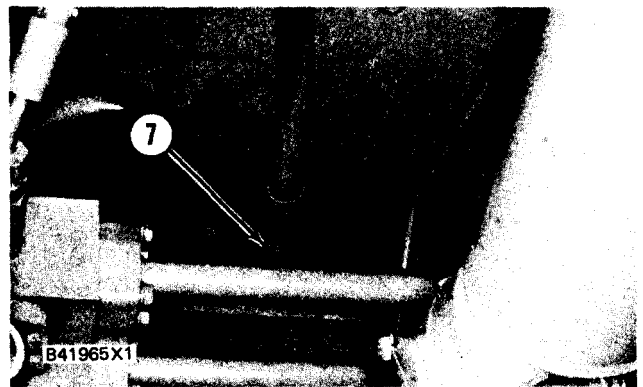

10. Install cover (8) and the nuts that hold it.

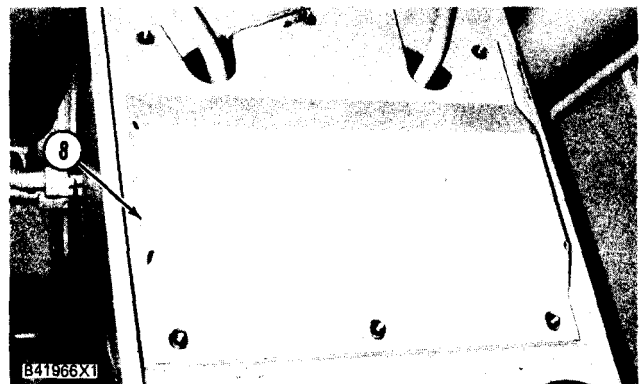

11. Use machine hydraulics to lift the loader frame and remove tooling (A). Lower the bucket to the ground.

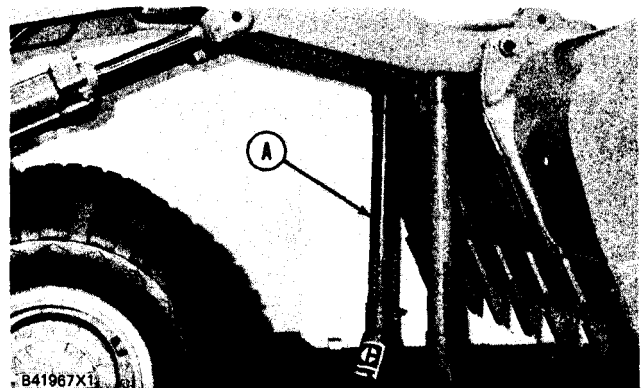

12. Remove the air from the hydraulic system. See REMOVE THE AIR FROM THE HYDRAULIC SYSTEM.

LOADER CONTROL VALVE

DISASSEMBLE LOADER CONTROL VALVE

5051-15

start by:

- a) remove loader control valve

NOTE: While the procedure set forth below is accompanied by illustrations of two spool loader control valves, the procedure is also adaptable to three spool (attachment) control valves with changes noted.

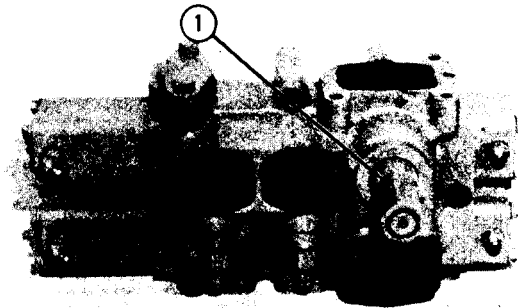

B30496X1

1. Remove main relief valve (1) from the loader control valve group.
2. Remove O-ring seals (3) and (4) from the valve.
3. Remove cap (2) from the valve.
4. Remove valve (6), spring (5) and the spacer from the cap.
5. Remove plug (7) and the O-ring seal from the cap.
6. Remove plunger (8) from the cap.

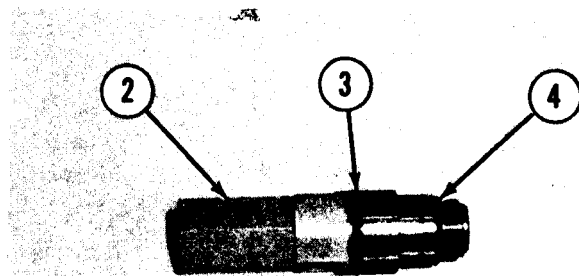

B30497X1

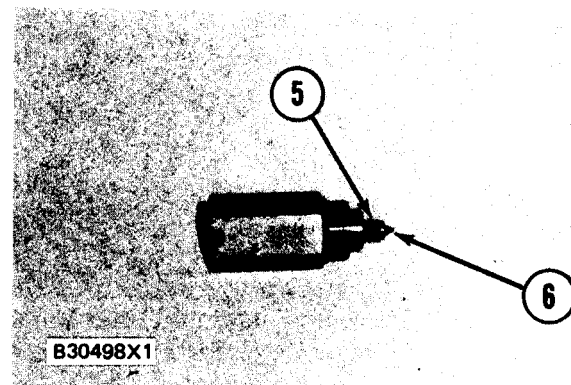

B30498X1

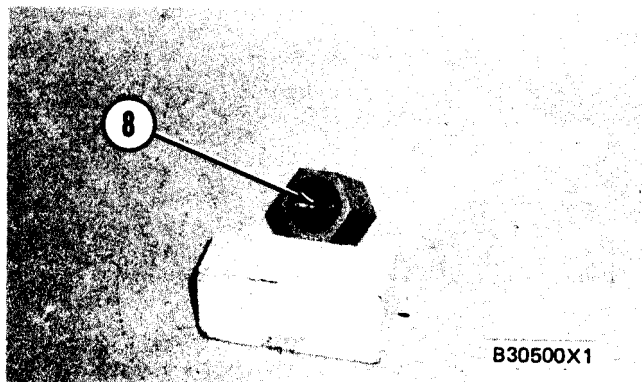

B30500X1

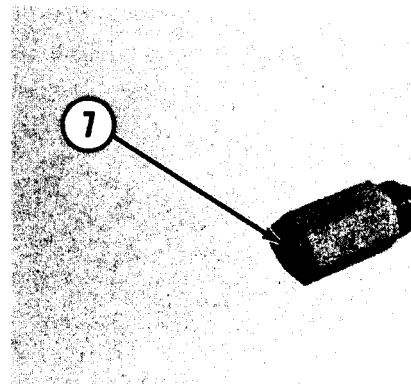

B30499X1

LOADER CONTROL VALVE

7. Put identification on relief valves (9) and (10) for assembly purposes.

8. Remove rod end tilt relief valve (10) and head end tilt relief valve (9) from the control valve.

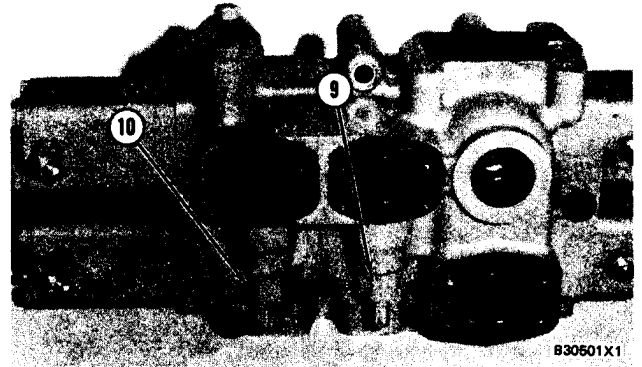

NOTE: In three-spool valves, remove the three additional relief valves.

9. Remove O-ring seals (11) and (12) from each relief valve.

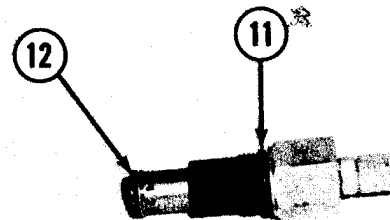

WARNING

Spring pressure is present behind plug (13). To prevent personal injury carefully remove plug (13).

10. Remove plug (13), spring (17) and valve (14) from the control valve.

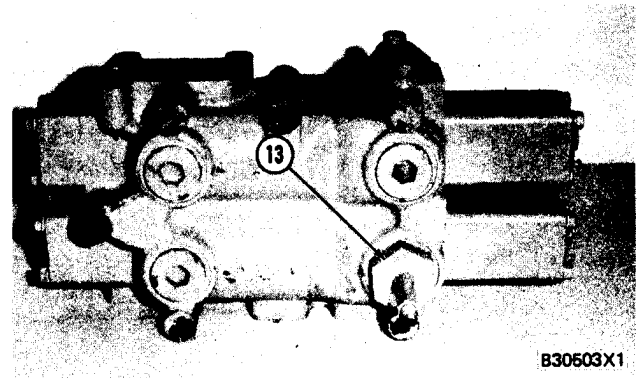

11. Remove fitting (16) and O-ring seal (18) from the plug.

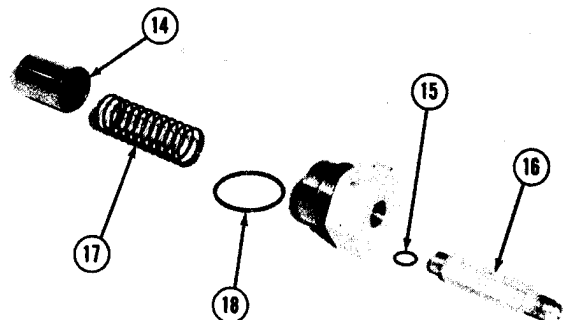

12. Remove O-ring seal (15) from the fitting.

LOADER CONTROL VALVE

CAUTION

Spring pressure is present behind plugs (19) in the valve group.

- Remove plugs (19), springs (21) and valves (20) from the valve group.

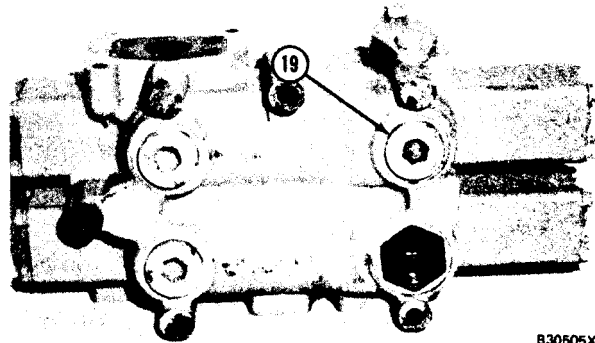

B30505X1

- Remove O-ring seals (22) from the plugs.

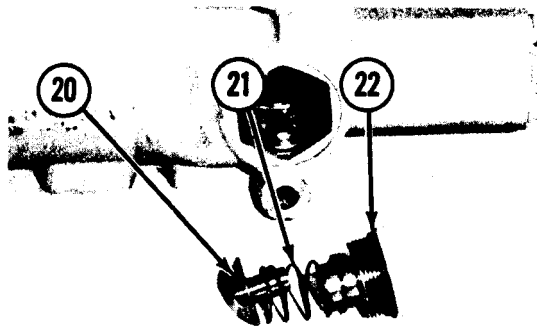

B30506X1

- Remove bolts (23) and housings (24) from the valve group.

- Remove the O-ring seals from the housings.

WARNING

Spring pressure is present in housing (25). To prevent personal injury carefully remove housing (25).

- Remove bolts (26) evenly and remove housing (25) from the valve group. Remove the O-ring seal from the housing.

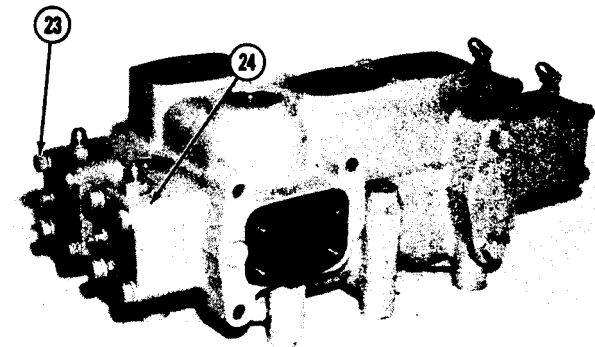

B30507X1

- Remove tilt circuit valve spool group (27) from the valve body.

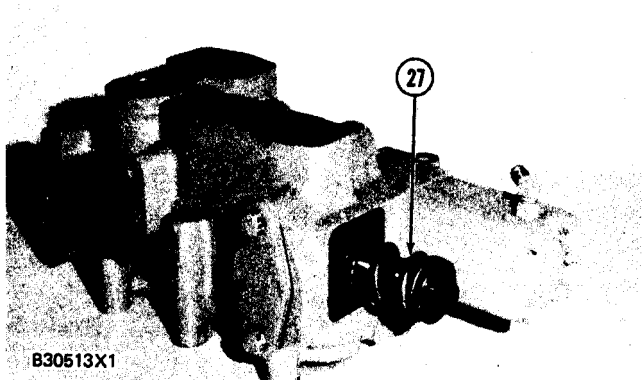

B30513X1

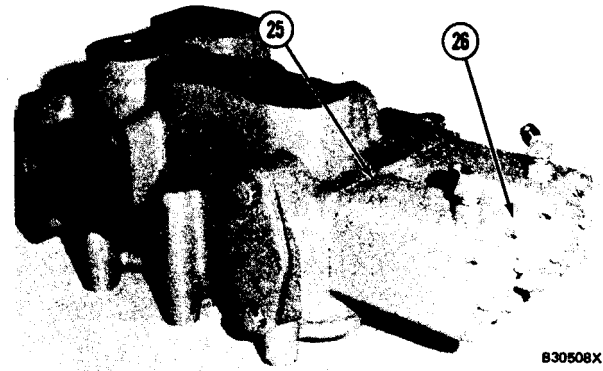

B30508X1

LOADER CONTROL VALVE

19. Remove the bolt, washer (34), retainer (30), spring (33), spring (29), shim (32) and retainer (28) from valve spool (31).

WARNING

Spring pressure is present in housing (35). To prevent personal injury carefully remove housing (35).

20. Remove the bolts evenly and remove housing (35) from the valve body.

21. Remove the O-ring seal from housing (35).

22. Remove lift circuit valve spool group (36) from the valve body.

23. Remove the bolt, washer (40), retainer (43), spring (39), spring (42), shim (41) and retainer (38) from valve spool (37).

24. a) On three spool (attachment) control valves, remove the bolts and housing from the attachment valve groups. Remove the O-ring from the housing.

- b) Remove the attachment circuit valve spool group from the valve body.

- c) Remove the bolt, washer, retainers, springs and shim from the valve spool.

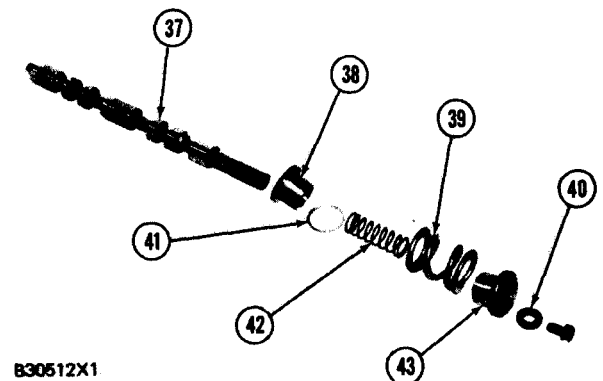
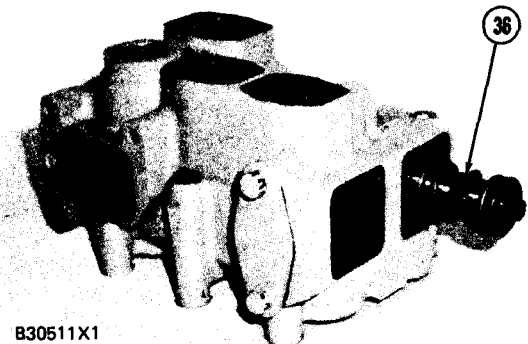
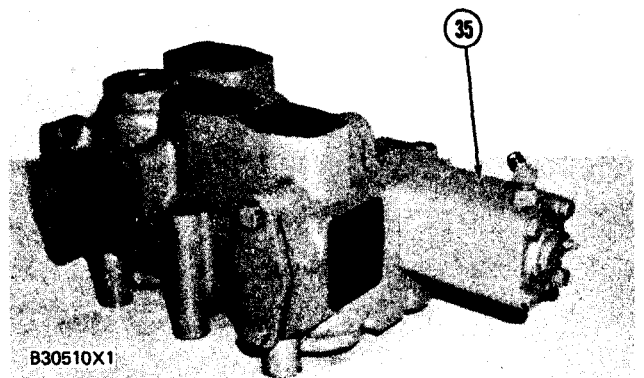
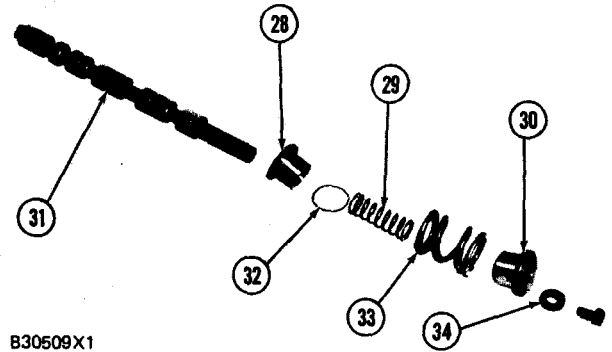

LOADER CONTROL VALVE

1. Inspect all parts for wear or damage. Make replacements if necessary.
2. Put clean oil on all parts when they are assembled.
3. Put retainer (2), shim (7), spring (3), spring (4), retainer (5), washer (8) and bolt (6) in position on lift circuit valve spool (1).

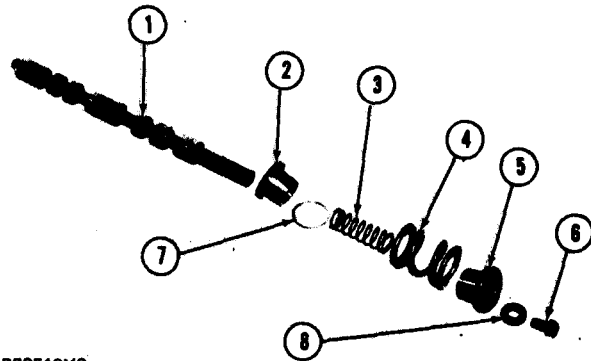

B30512X2

4. Install lift circuit valve spool assembly (10) in control valve body (9).
5. Put retainer (12), spacer (16), springs (13) and (14), retainer (17), washer (15) and bolt (18) on tilt circuit valve spool (11).

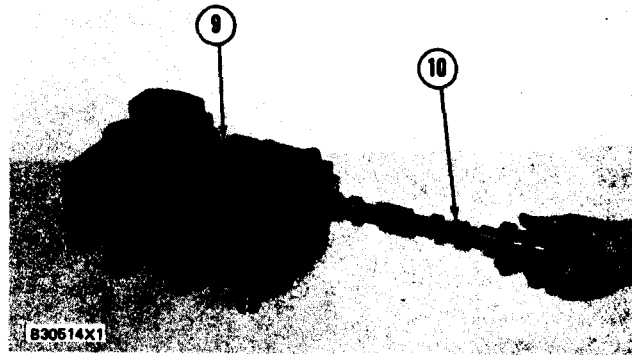

B30514X1

6. Install tilt circuit valve spool assembly (19) into the valve body.

NOTE: On three spool valves, place retainers, shim, springs, washer and bolt in position on attachment valve spool and install assembly in control valve body.

7. Put the O-ring seals in position in housings (20).

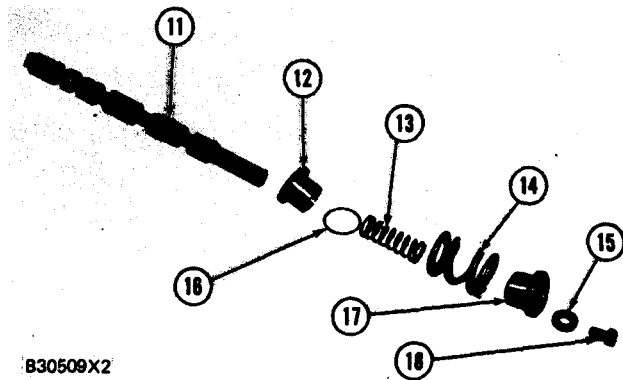

B30509X2

8. Install housings (20) and the bolts.

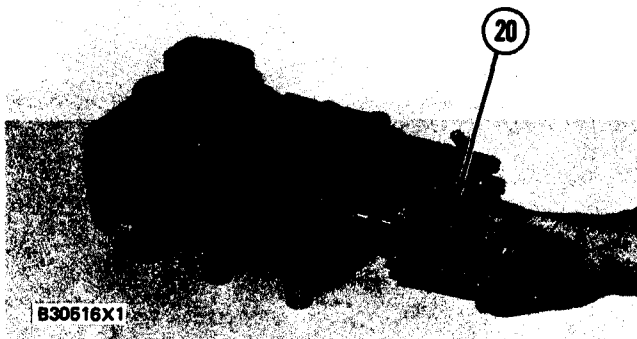

B30516X1

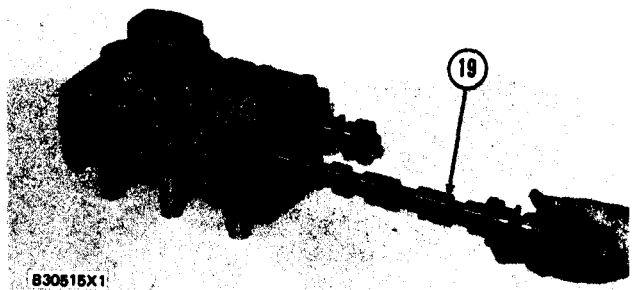

B30515X1

LOADER CONTROL VALVE

9. Put O-ring seal (22) in position on plate (21).

10. Install plate (21) on the valve body.

11. Put O-ring seals (24) in position in housings (23).

12. Install housings (23) on the valve body.

13. Put valves (25) in position in the body,

14. Put springs (26) in position.

15. Put O-ring seals (27) in position on plugs (28).

16. Install the plugs in the valve body.

17. Put valve (29) in position as shown.

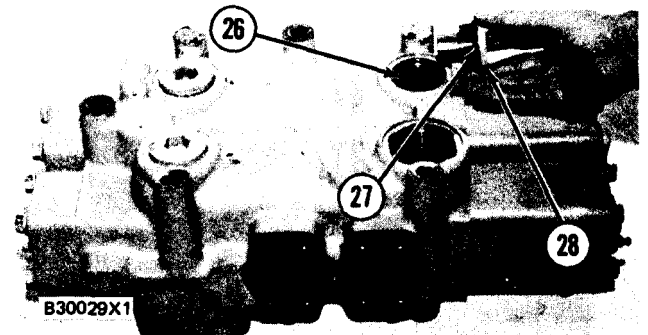
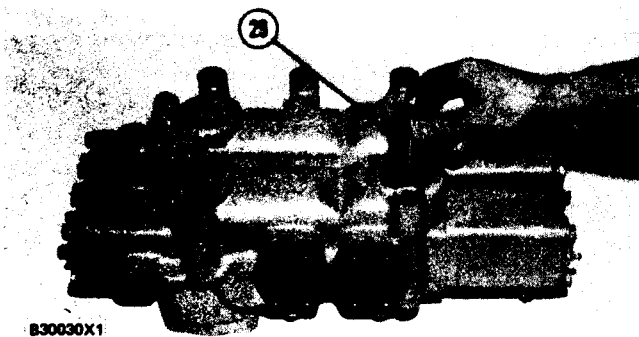
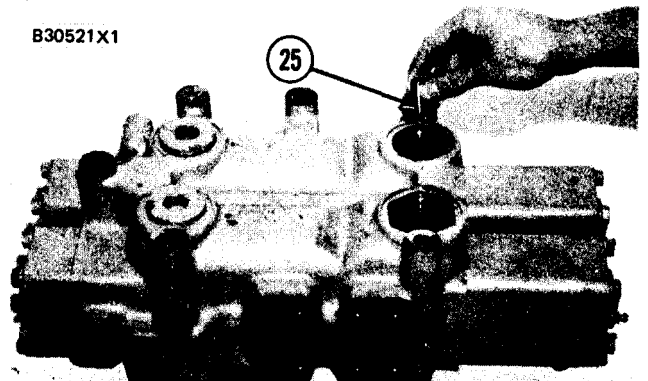
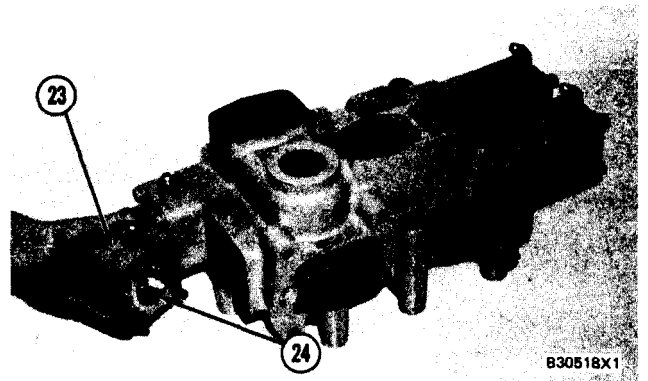
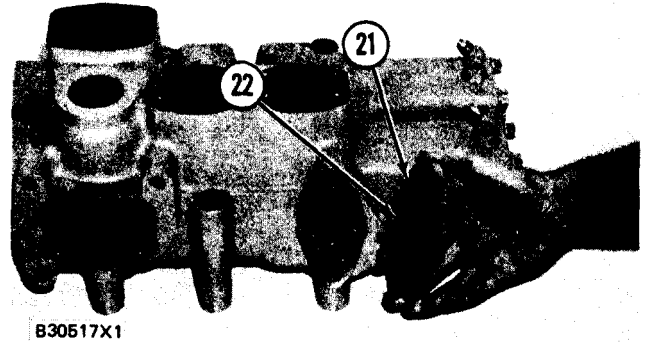

LOADER CONTROL VALVE

18. Put spring (31) in position in the valve.

19. Put O-ring seal (30) on plug (32).

20. Install the plug in the valve body.

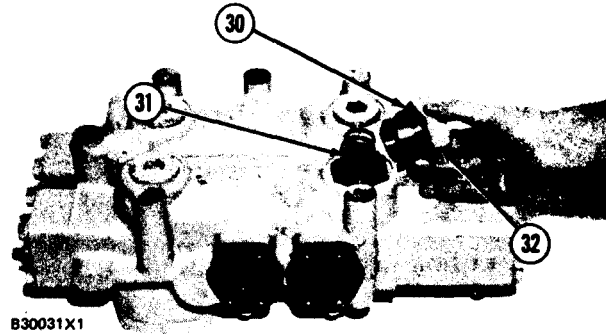

21. Put O-ring seal (33) in position and install fitting (34) in the plug.

22. Put O-ring seals (35) and (36) on relief valves (37).

23. Install relief valves (37) in the valve body in their original position.

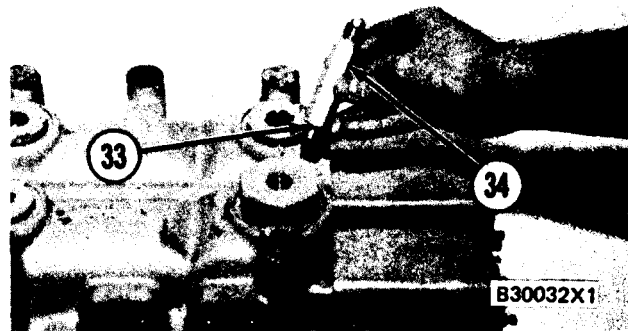

24. Put O-ring seals (42) and (48) on valve (47).

25. Put O-ring seal (45) in position on cap (39).

26. Put spacer (40), spring (46) and valve (41) in position in the cap.

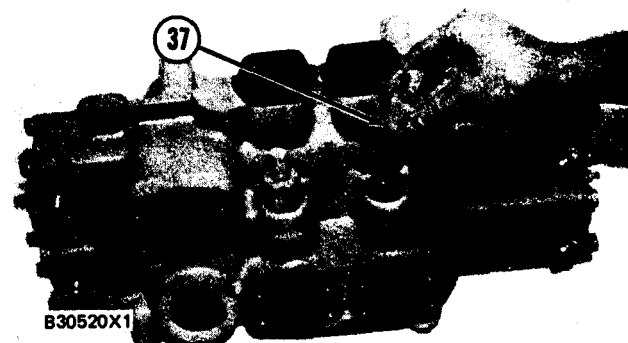
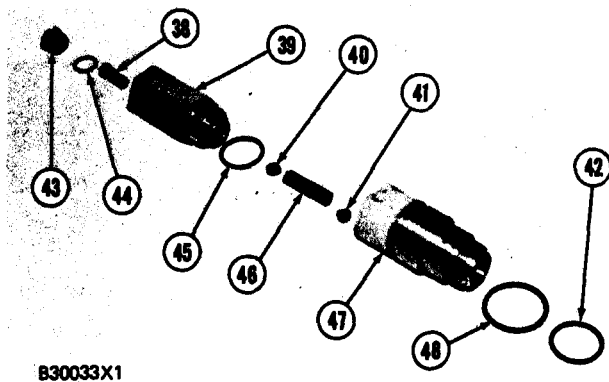
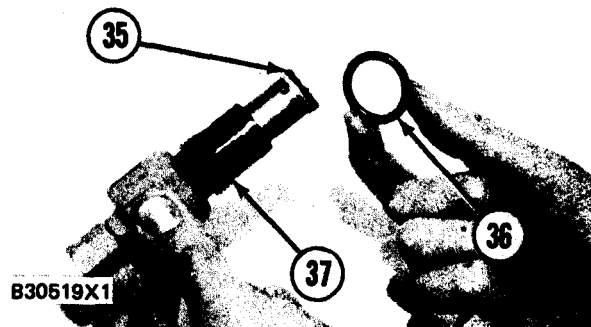

LOADER CONTROL VALVE

27. Install valve (47) on cap (39).

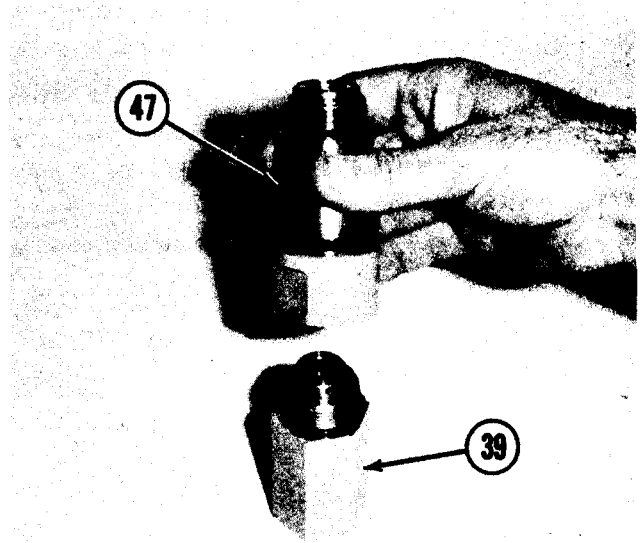

B30034X1

28. Put plunger (38) in its original position in the cap.

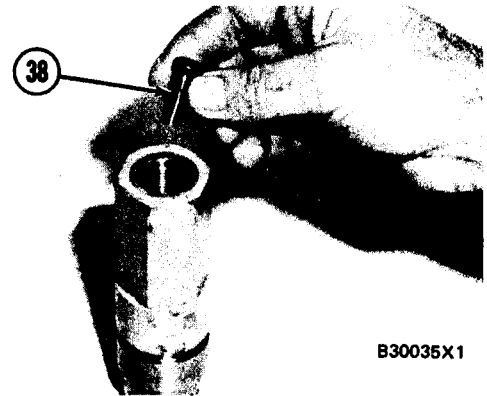

B30035X1

29. Put O-ring seal (44) in position on plug (43).

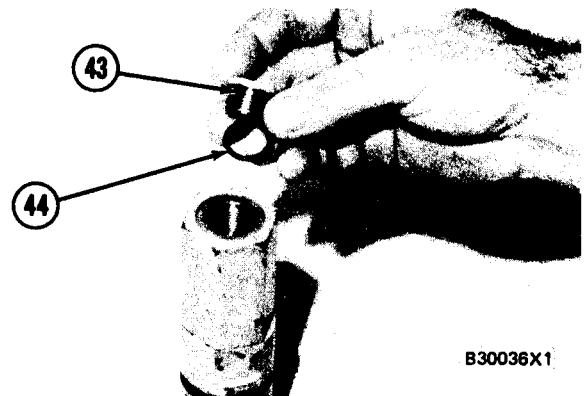

B30036X1

30. Install the plug in the cap.

31. Install main relief valve (49) in the control valve.
end by:
a) install loader control valve

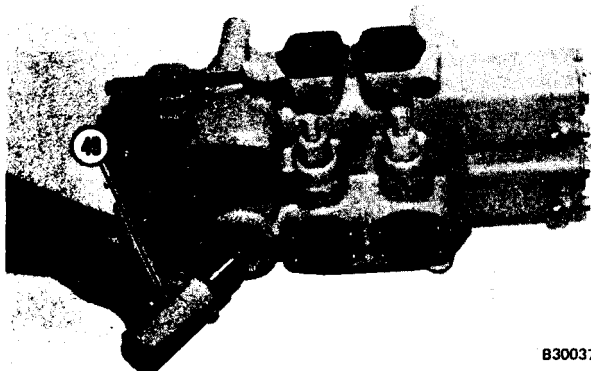

B30037X1

PILOT CONTROL VALVE

REMOVE PILOT CONTROL VALVE 5059-11

WARNING

To prevent personal injury release the pressure from the hydraulic system before any lines are removed or disconnected.

1. Open the access panel on the exterior right side of the cab.
2. Put identification on lines (1) and (2) for assembly purposes.
3. Disconnect hoses (1) and hose (2) from the bottom of the pilot control valve, and put caps or plugs in the end.

3. Remove the caps or plugs from the end of the hoses. Connect hoses (1) and hose (2) to the pilot control valve.

4. Close the access panel on the exterior right side of the cab.

5. Remove the air from the hydraulic system. See REMOVE THE AIR FROM THE HYDRAULIC SYSTEM.

4. Disconnect two linkages (3) from pilot control valve (4).

5. Remove bolts (5), and remove pilot control valve (4).

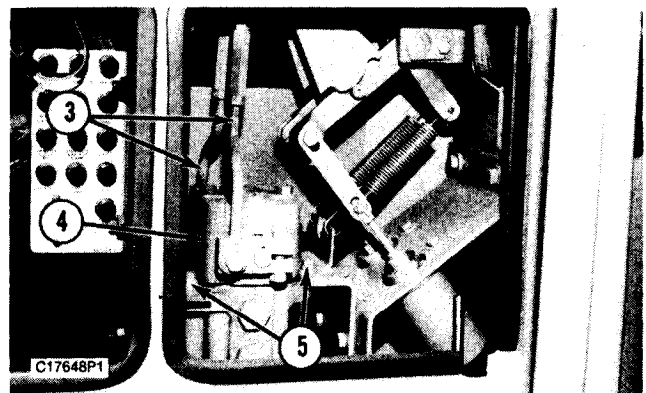
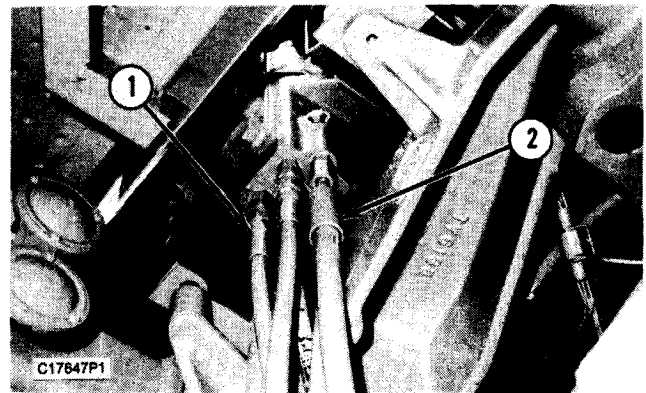

INSTALL PILOT CONTROL VALVE 5059-12

1. Install pilot control valve (4) and bolts (5) that hold it.
2. Connect two linkages (3) to the pilot control valve.

PILOT CONTROL VALVE

INSTALL PILOT CONTROL VALVE 5059-12

1. Install bracket (1) in position on the valve and install the two bolts.

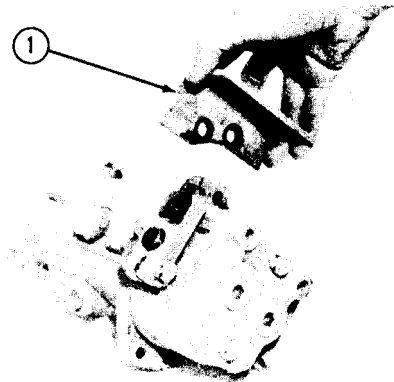

B30357X1

2. Put the valve (2) in position and install four bolts (3) that hold the valve in place.



B20070X1

3. Connect two linkages (4) to the valve.

4. Remove the plugs or caps from the lines.

5. Connect lines (5) to the valves.

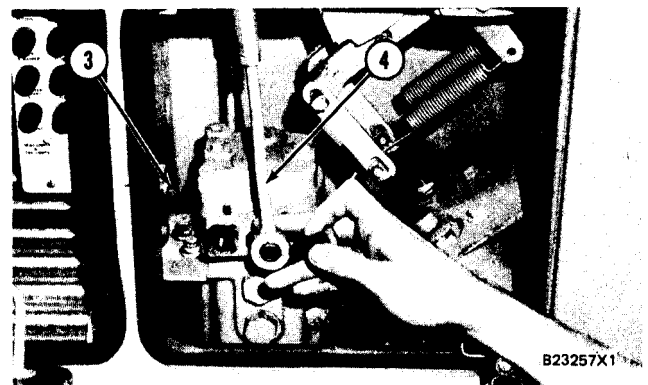

B23257X1

6. Put access panel (6) in the "CLOSED" position.

7. Remove the air from the hydraulic system. See REMOVE THE AIR FROM THE HYDRAULIC SYSTEM.

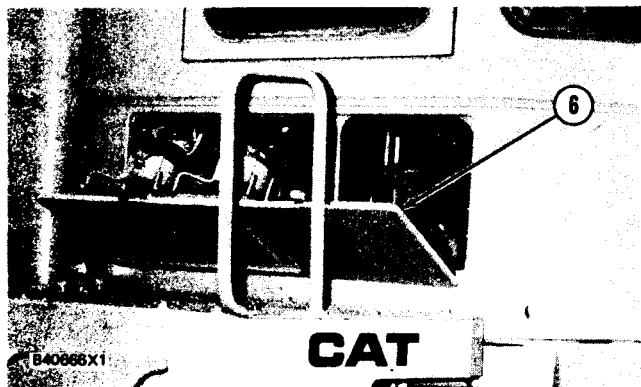

B40665X1

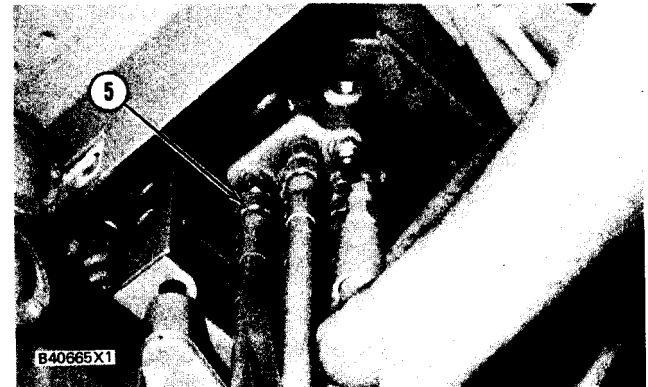

B40665X1

PILOT CONTROL VALVE

DISASSEMBLE PILOT CONTROL VALVE

5059-15

start by:

a) remove pilot control valve

1. Put identification on cover (3) and valve body (2) for assembly purposes.

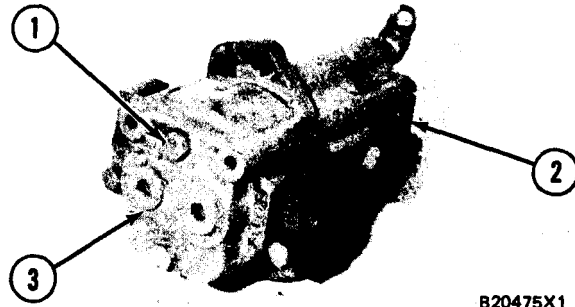

B20475X1

2. Remove bolts (1) and make a separation of cover (3) and valve body (2).

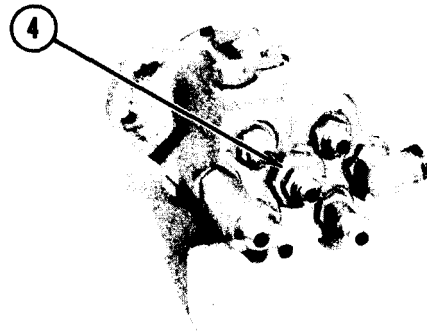

B22029X1

3. Remove fitting (4) from the valve body.

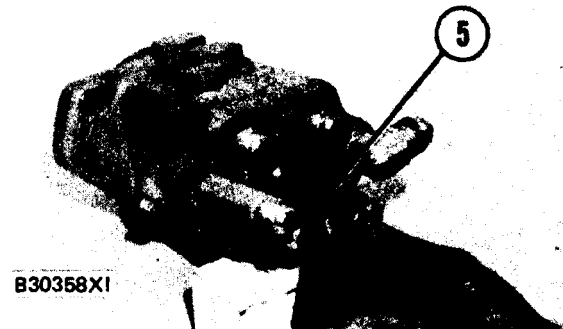

B30358X1

4. Remove the setscrew and screen assembly (5).

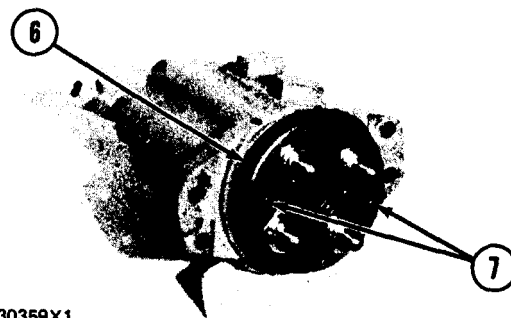

B30359X1

5. Remove O-ring seals (6) and (7) from the valve body.

PILOT CONTROL VALVE

NOTE: Plunger assemblies (9) and (8) are different. Plunger assembly (8) is longer than the others. Put identification on the plunger-assemblies for assembly purposes.

WARNING

Spring pressure is present behind sleeves (14) in the body. To prevent personal injury carefully remove jam nuts (13).

- Remove jam nuts (13), sleeves (14), plungers (12), stem assemblies (11) and springs (10) from the body.

- Remove retainer (17), spacer (16), retainer (19) and spring (15) from stem (18).

- Remove bolts (20) and links (21) from the cover. Remove the key from the shaft.

- Remove plugs (22) and the O-ring seals from the cover.

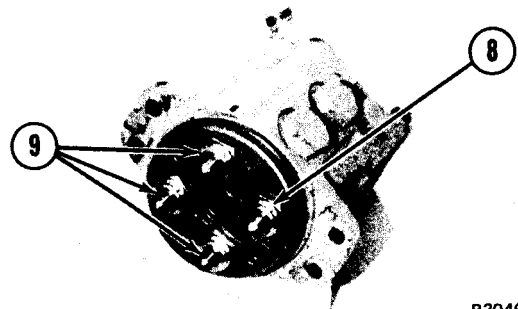

B30462X1

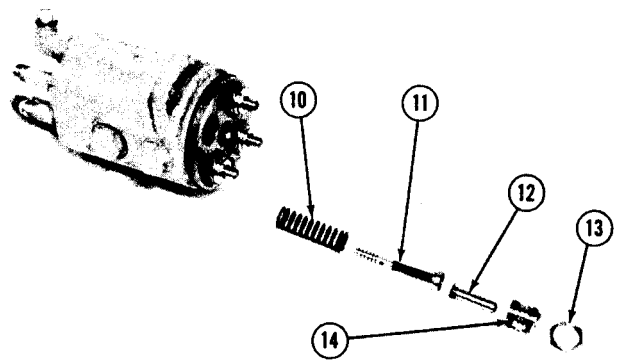

B30463X1

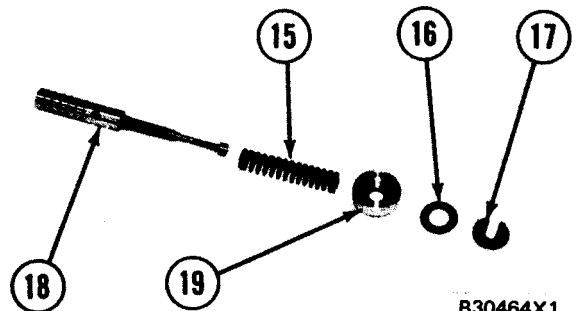

B30464X1

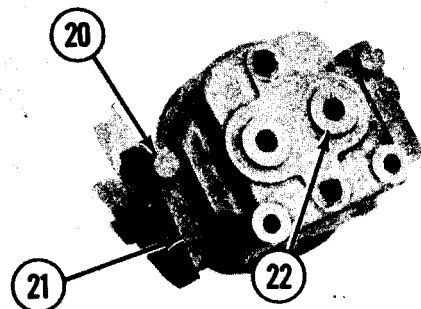

B30465X1

PILOT CONTROL VALVE

10. Remove setscrews (23) from the actuator.

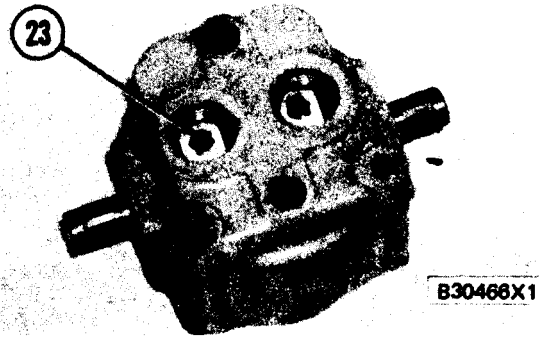

11. Use a hammer and a punch to remove pin (24) from the shaft.

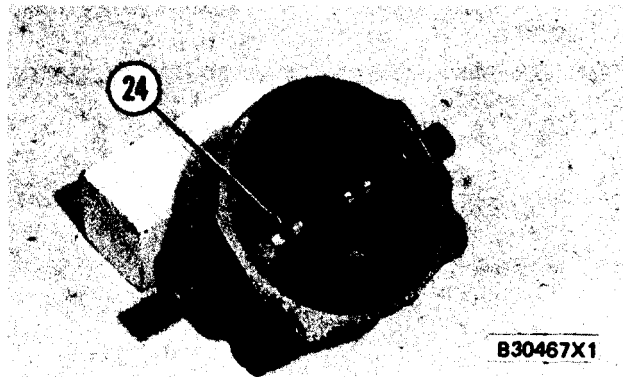

12. Remove shafts (27), washers (26) and actuator (25) from the cover.

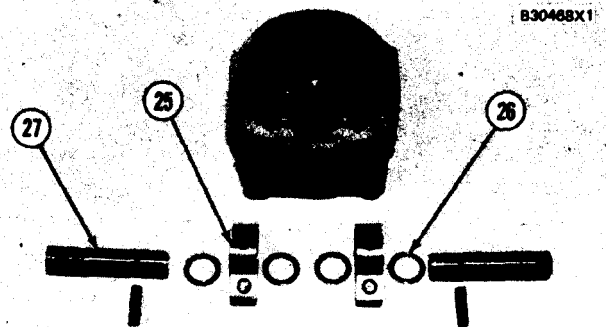

13. Remove seals (28) from the cover.

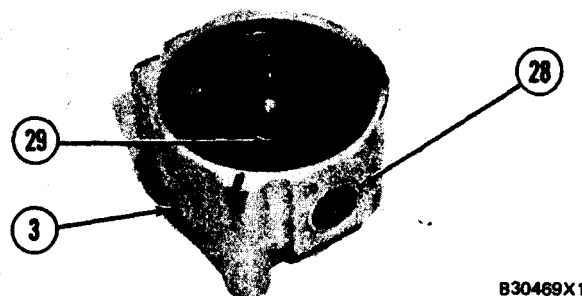

14. Remove bearings (29) from cover (3).

PILOT CONTROL VALVE

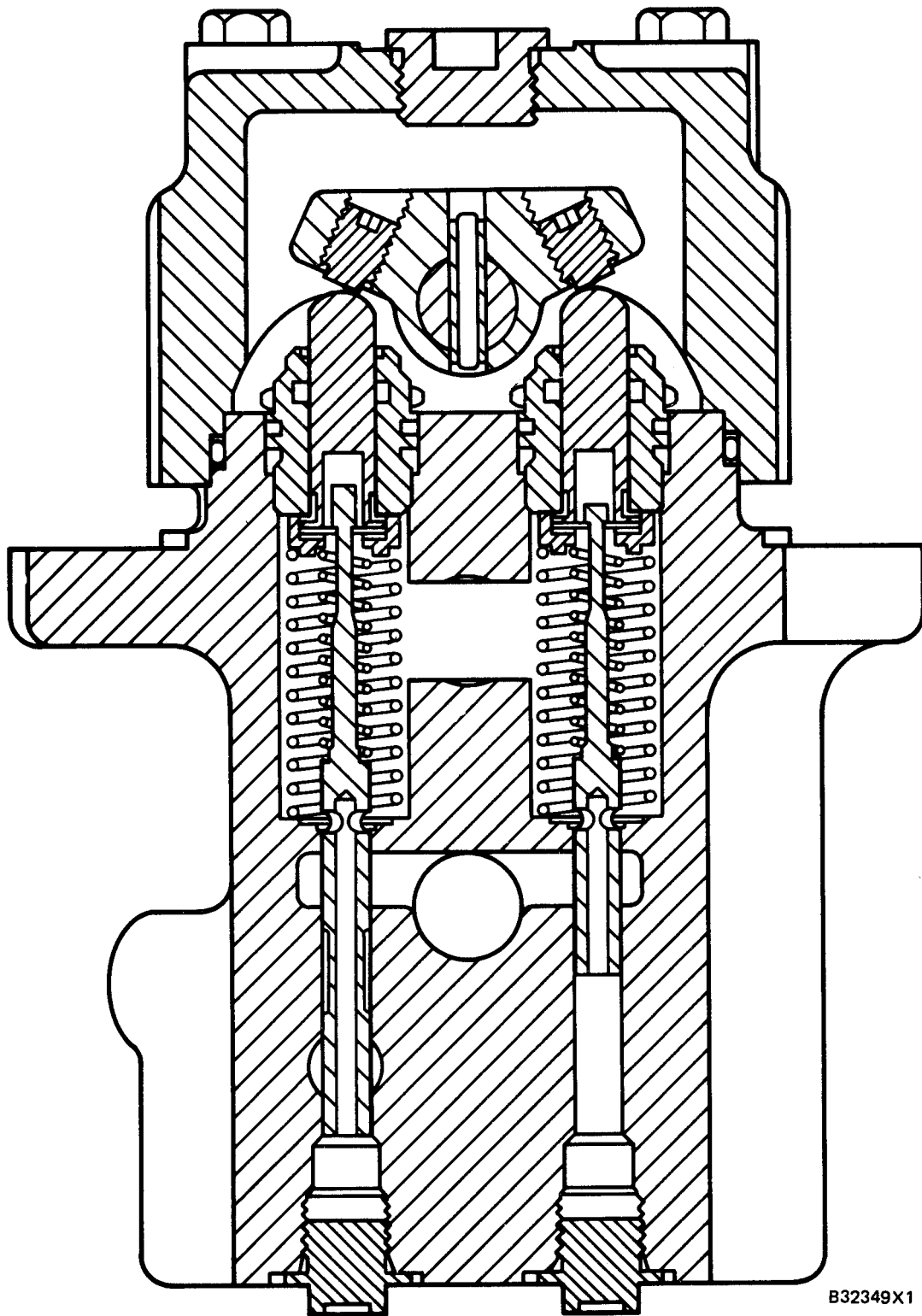

B32349X1

PILOT CONTROL VALVE

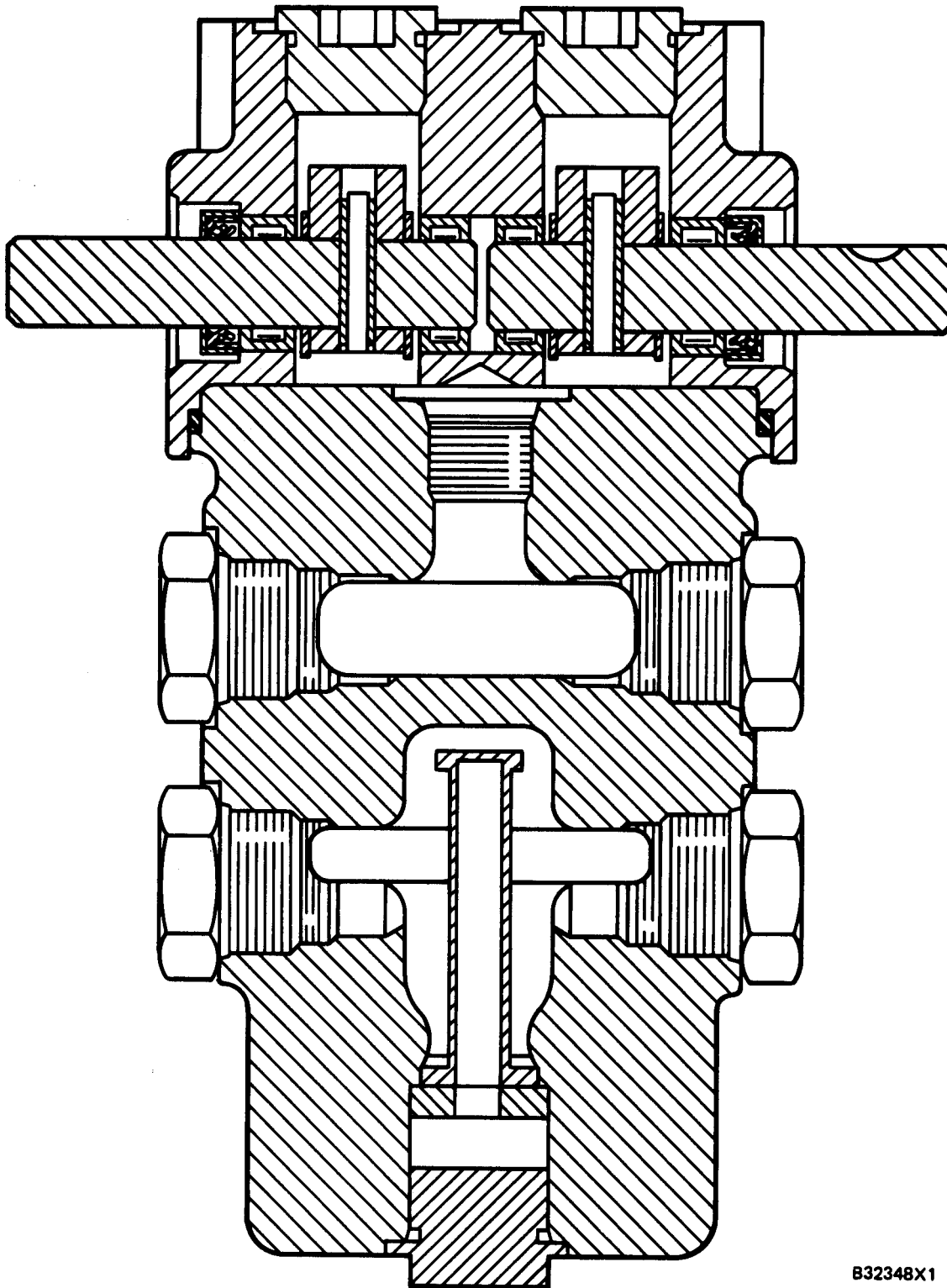

B32348X1

PILOT CONTROL VALVE

ASSEMBLE PILOT CONTROL VALVE 5059-16

Tools Needed		A
1P510	Driver Group	1

1. Make sure all parts are clean. Inspect all parts for wear or damage. Make replacements if necessary.

2. Use tool (A) to install bearings (1) in cover (2). Push only on the stamped side of the bearing. The bearings must be even with outside surface.

3. Install the lip type seals with tool (A). The lip of the seal must be toward the inside. Put clean oil on the lips of the seals.

4. Put shafts (4), washers (3) and actuators (5) in position in the cover. Make sure a washer is on each side of the actuator.

5. Use a hammer and a punch to install pins (6) in the actuator and shaft. The key groove in the shaft must be toward the top of the cover.

6. Turn the cover over and install setscrews (7) in the actuator. The bottom of the setscrew must be even with the surface of the actuator.

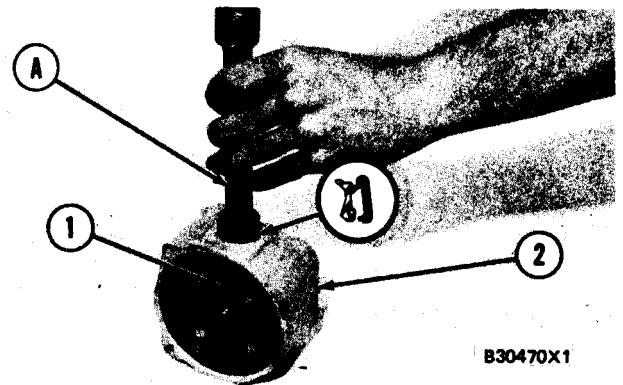

B30470X1

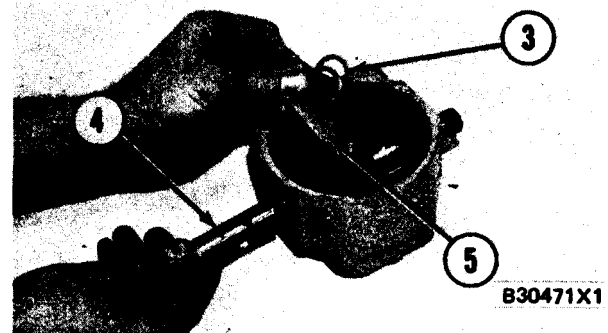

B30471X1

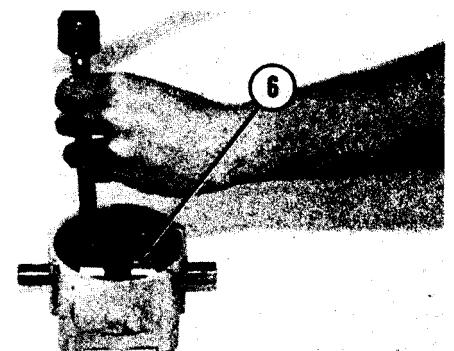

B30472X1

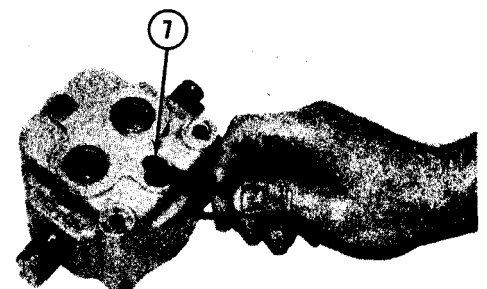

B30473X1

PILOT CONTROL VALVE

7. Put O-ring seal (8) in position on plug (9).
Install plugs (9) in the cover.

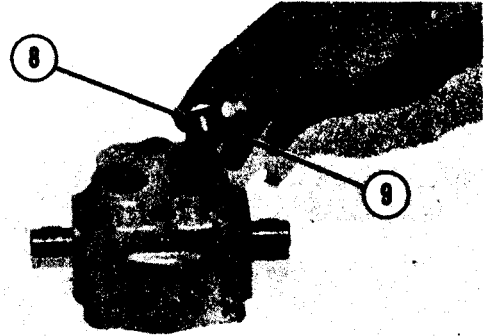

B30474X1

8. Install keys (11) in the shafts.

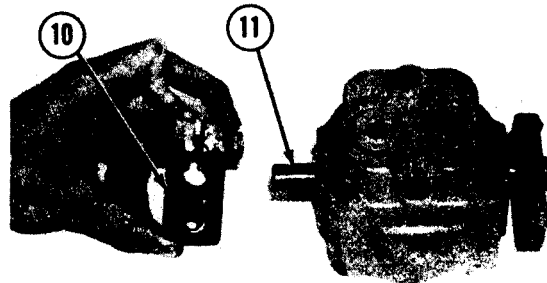

B30475X1

9. Put links (10) in position on the shaft and tighten the bolts.

10. Install the screen assembly in the valve body.

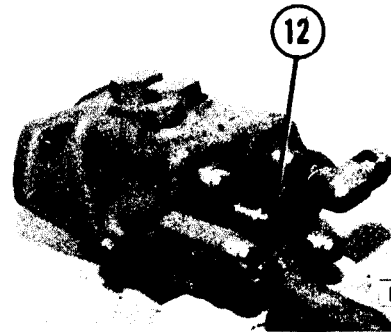

B30476X1

11. Install setscrew (12) to hold the screen in place.

12. Put O-ring seal (13) in position on fitting (14).

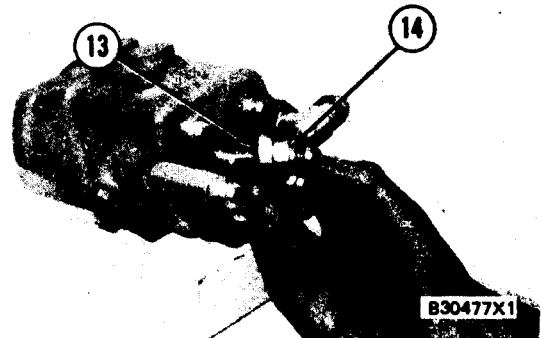

B30477X1

13. Install fitting (14) in the valve body.

PILOT CONTROL VALVE

NOTE: Use spacers (17) as needed to get a preload of 15.0 ± 2.5 N ($3.5 \pm .6$ lb.) on springs (16) when the unit is assembled.

14. Install springs (16), retainers (19), spacers (17) and retainers (18) on stems (15). Make sure retainer (19) is installed with the counter-bore toward the small end of the stem.

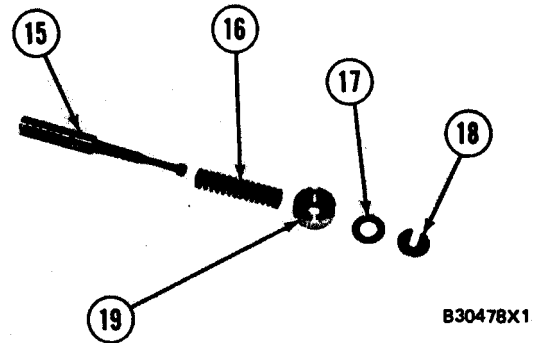

NOTE: Stems (15) must be $.015 - .020$ mm ($.0006 - .0008$ in.) loose fit with their respective bore in the body.

15. Install springs (20), the stem assembly, plungers (22) and sleeves (21) into the body.

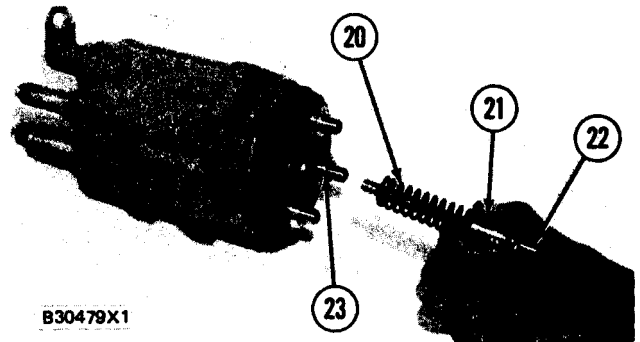

16. Install the sleeves 5 ± 1 turns into the valve body.

17. Install the jam nut but do not tighten it until after a test has been made of the valve.

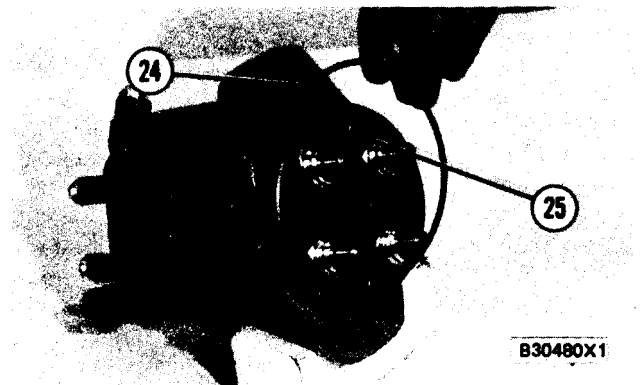

18. Make sure plunger assembly (23) has the long stem.

19. Install O-ring seals (24) and (25) on the valve body.

20. Install cover (2) on valve body (26) in its original position. Install the bolts.

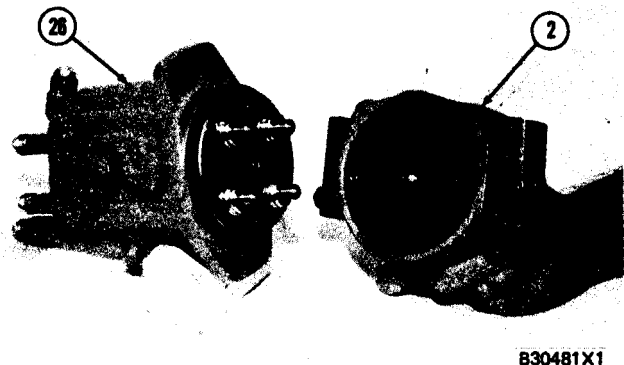

21. To test the control valve, see TESTING AND ADJUSTING.
end by:
a) install pilot control valve

SELECTOR AND PRESSURE CONTROL VALVE

REMOVE AND INSTALL SELECTOR AND PRESSURE CONTROL VALVE 5072-10

WARNING

To prevent personal injury release the pressure from the hydraulic system before any lines are removed or disconnected.

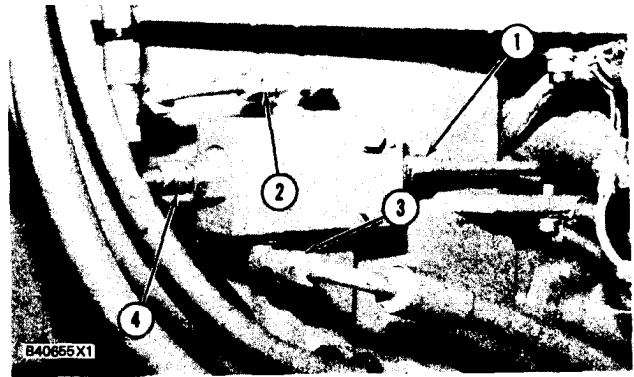

1. Put marks on all lines for assembly purposes.

2. Disconnect hose assemblies (2), (3) and (4) and tube assembly (1) from the control valve.

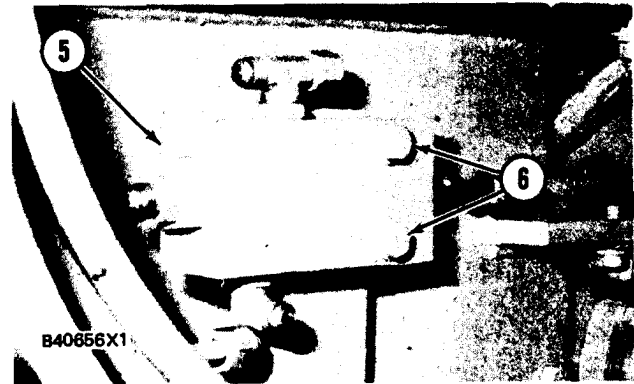

3. Remove bolts (6) and selector and pressure control valve (5) from the machine.

4. Put the control valve in position on the machine and install bolts (6).

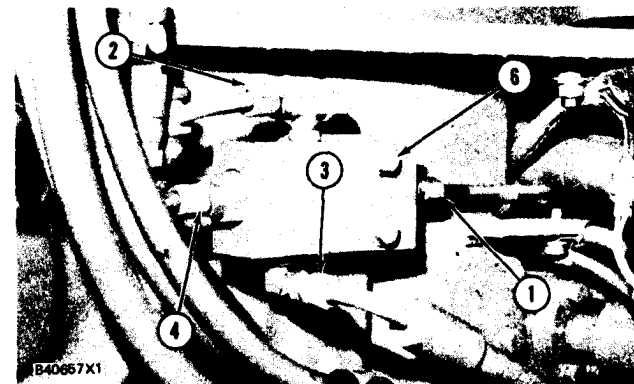

5. Connect hose assemblies (2), (3) and (4) and tube assembly (1) on the control valve.

DISASSEMBLE SELECTOR AND PRESSURE CONTROL VALVE 5072-15

start by:

a) remove selector and pressure control valve

1. Remove fittings (1) and (2) from the selector and pressure control valve.

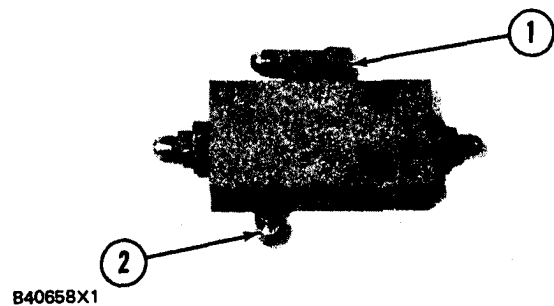

SELECTOR AND PRESSURE CONTROL VALVE

2. Remove fittings (3) and (5) from the control valve.
3. Remove O-ring seals (4) and (6) from the fittings.
4. Remove fittings (10) and (13), shims (12), springs (7) and stem (11) from the control valve.
5. Remove O-ring seals (9) and (8) from the fittings.

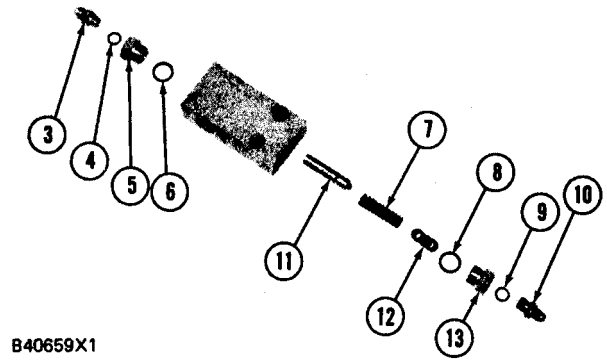

ASSEMBLE SELECTOR AND PRESSURE CONTROL VALVE 5072-16

1. Install O-ring seals (2) and (4) on fittings (1) and (3).
2. Install fittings (1) and (3) in the control valve.
3. Install O-ring seals (6) and (7) on fittings (8) and (n).
4. Install stem (9), spring (5), original shims (10) and fittings (11) and (8) in the control valve.
5. Install O-ring seal (12) on fitting (13).
6. Install fitting (13) in the control valve.
7. Install O-ring seal (14) on fitting (15).
8. Install fitting (15) in the control valve.
end by:
a) install selector and pressure control valve

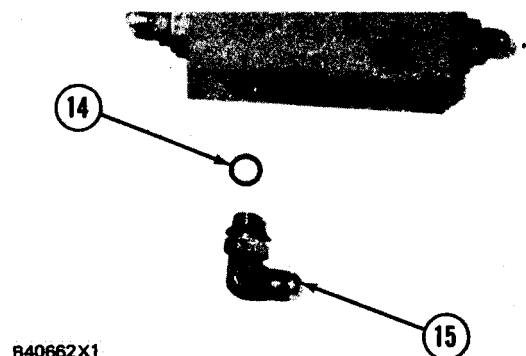
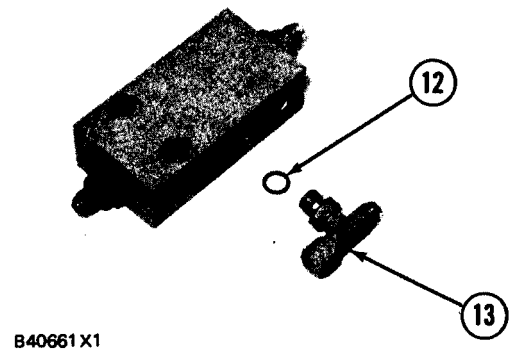
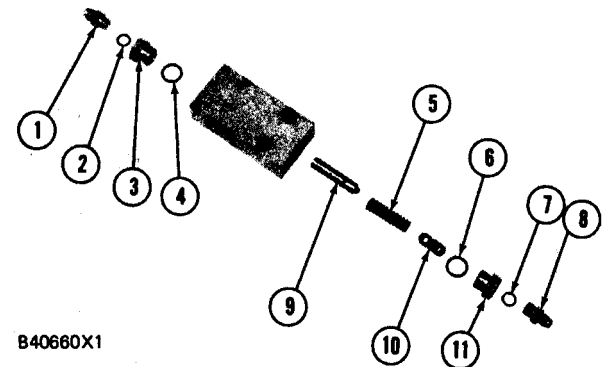

TILT CYLINDER

REMOVE TILT CYLINDER

5104-11

Tools Needed		A	B
9S5558	Stud, 1 1/4 in.	1	1
5P3100	Pump Group (or electric)	1	1
1P544	Nut	1	1
4K684	Washer	1	1
6V86	Adapter	1	
4M8484	Sleeve		1
6V4035	Sleeve Assembly		1

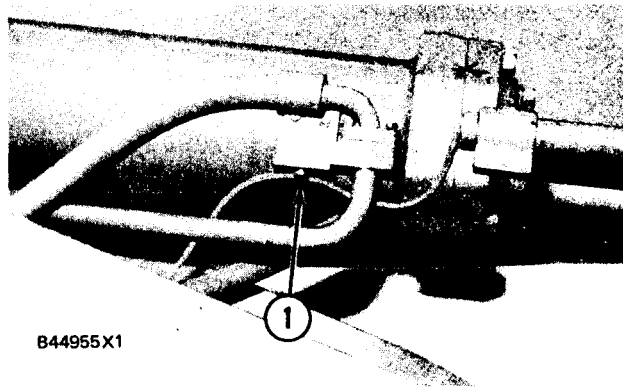

1. Remove the bolt and disconnect clip (1) from the bracket.

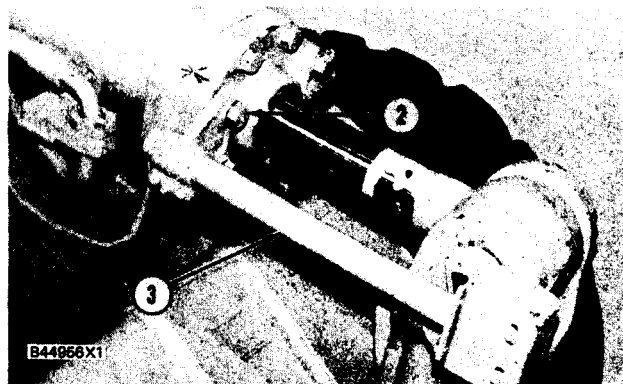

2. Remove bolts (2) and disconnect bucket positioner (3) from the cylinder.

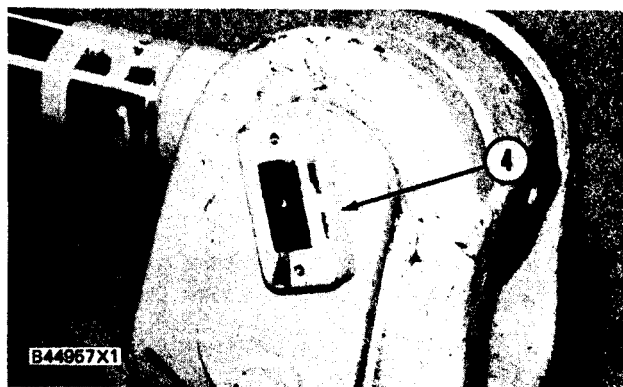

3. Loosen the two setscrews and remove magnet assembly (4) from the pin.

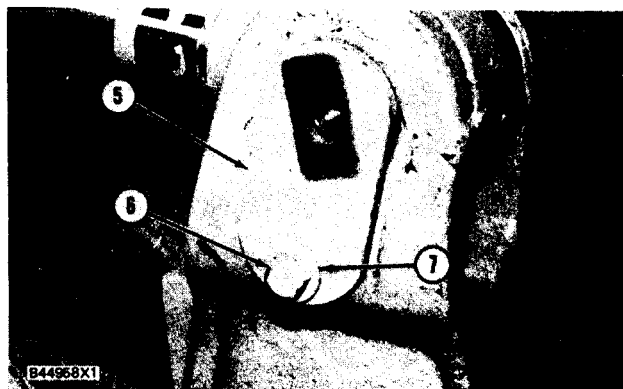

4. Remove bolt (6), washer (7) and the spacer from pin (5).

TILT CYLINDER

5. Fasten a hoist to the cylinder.

6. Put tooling (A) in position on the pin. Fasten a hoist to tooling (A) so it does not fall when the pin is removed. Remove the pin from the machine.

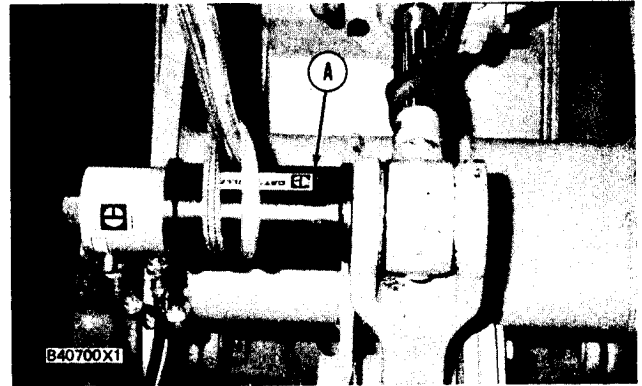
**WARNING**

To prevent personal injury release the pressure from the hydraulic system before any lines are removed or disconnected.

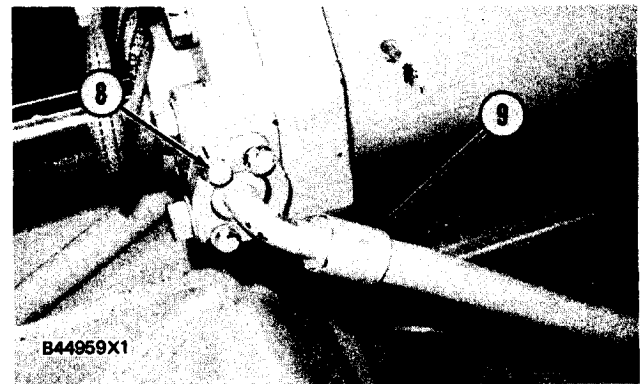

7. Remove bolts (8) and disconnect hose assembly (9) from the cylinder.

NOTE: To prevent any oil loss put caps or plugs in the lines that are disconnected.

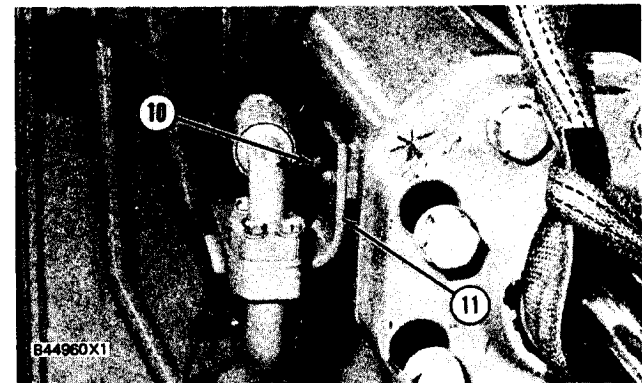

8. Remove bolts (10) and disconnect bracket (11) from the cylinder.

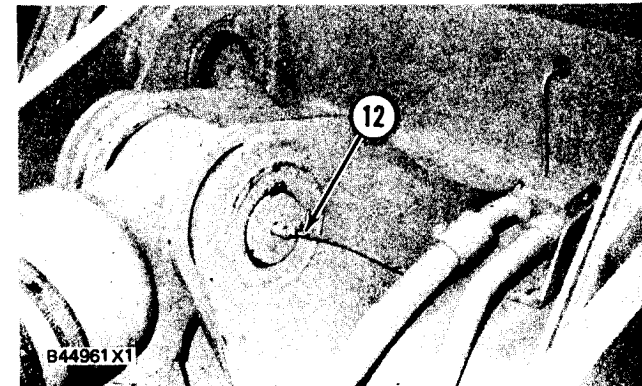

9. Disconnect grease line (12) from the pin.

TILT CYLINDER

10. Remove bolts (14) and tube assembly (13) from the tilt cylinder.

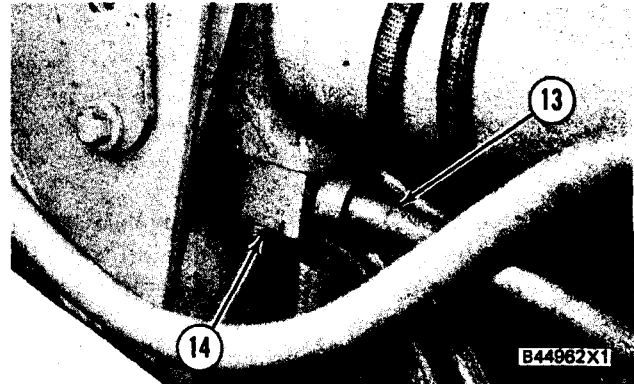

11. Remove bolt (16), washer (17) and the spacer from pin (15).

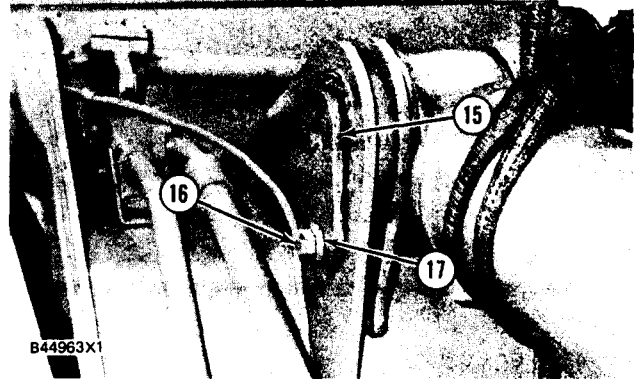

12. Put tooling (B) in position on pin (15), Fasten a hoist to tooling (B) so it does not fall when the pin is removed.

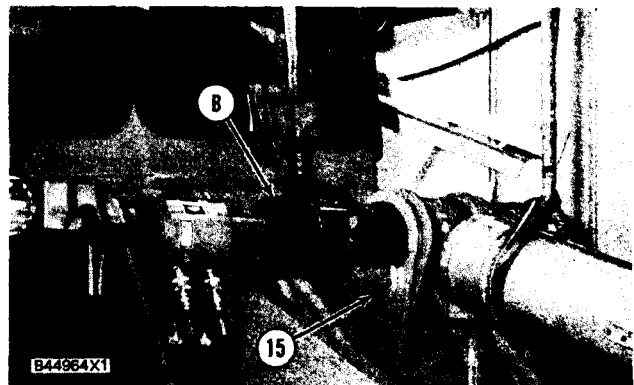

13. Remove pin (15) from the machine.

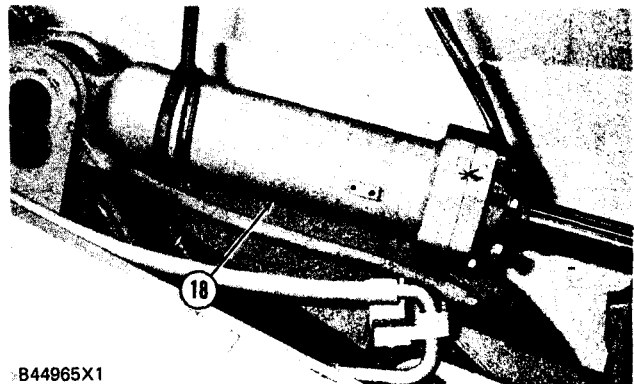

14. Remove tilt cylinder (18) from the machine, The weight of the cylinder is 176 kg (390 lb.).

TILT CYLINDER

INSTALL TILT CYLINDER

5104-12

1. Put 5P960 Multipurpose Type Grease in all the pin bores.

2. Fasten a hoist to tilt cylinder (1). Put the tilt cylinder in position.



CAUTION
Do not damage the seals when the pins are installed.

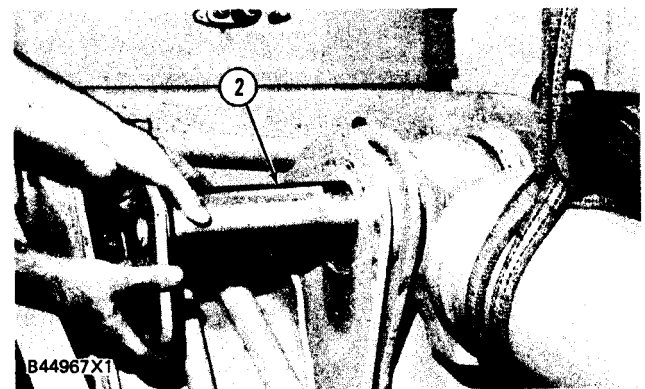

3. Put pin (2) in position in the rear bore.

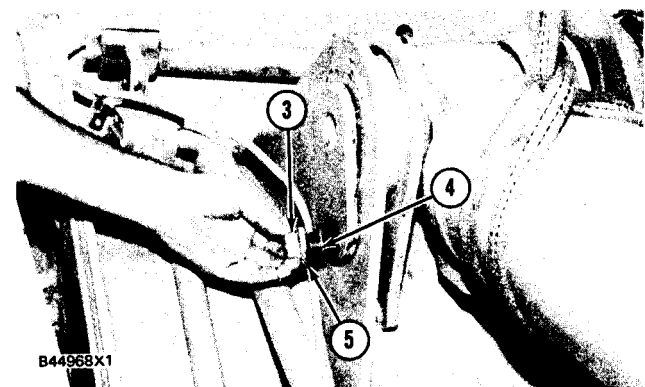

4. Install spacer (4), washer (5) and bolt (3) that holds the pin in place.

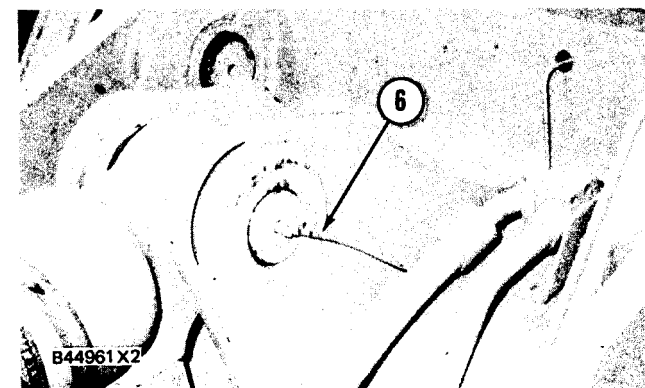

5. Connect grease line (6) to the pin.

TILT CYLINDER

6. Install pin (7) in the rod end of the cylinder.

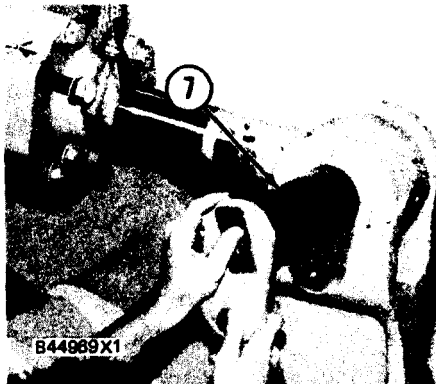

7. Install spacer (9), washer (8) and bolt (10) that holds the pin in place.

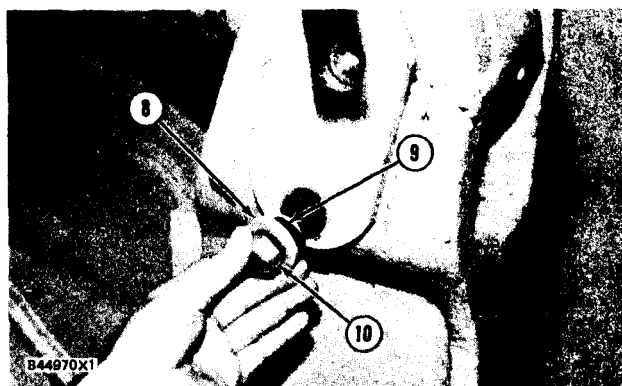

8. Install magnet (11) in the pin and tighten the setscrews.

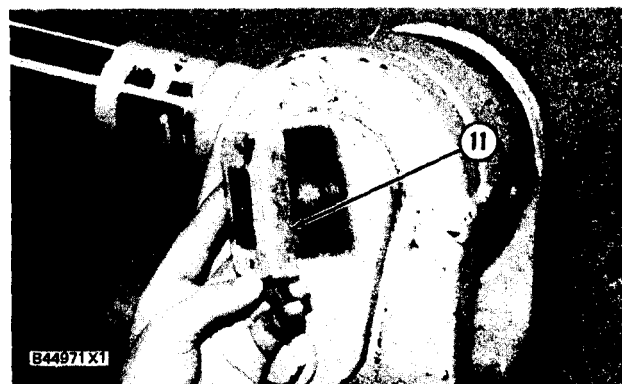

9. Connect tube assembly (12) to the cylinder.

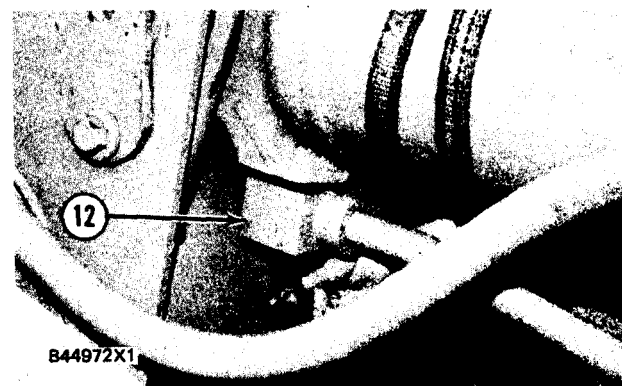

TILT CYLINDER

10. Connect bracket (13) to the cylinder.

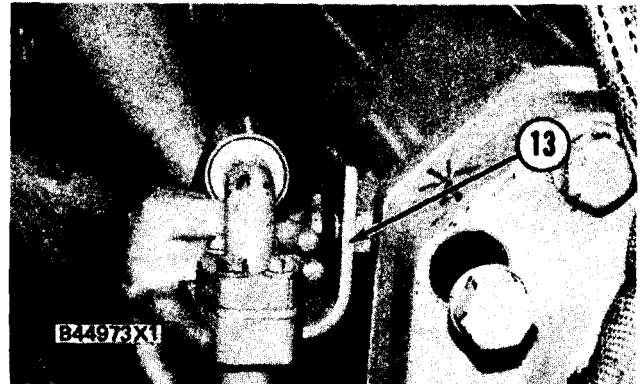

11. Connect hose assembly (14) to the cylinder.

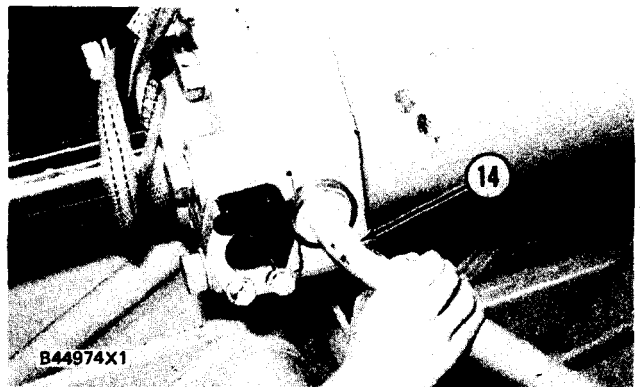

12. Put bucket positioner (15) in its original position. Install two bolts (16) that hold the bucket positioner in place.

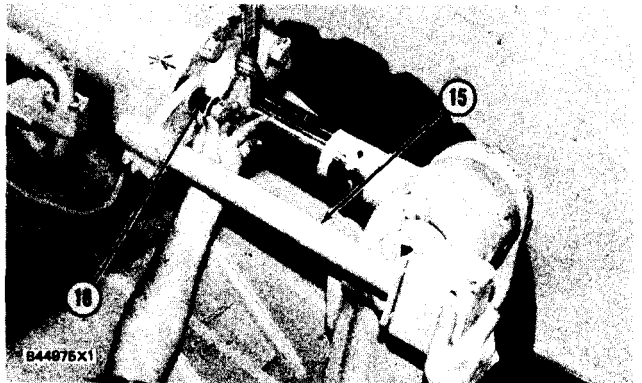

13. Connect clip (17) that holds the wire harness to the bracket.

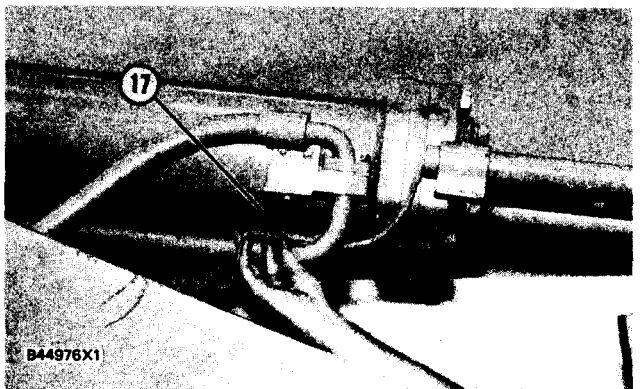

TILT CYLINDER

DISASSEMBLE TILT CYLINDER

5104-15

Tools Needed		A	B
6V4948	Hydraulic Cylinder Repair Stand	1	
5P3100	Pump Group (or electric)	1	
6V109	Torque Multiplier		1
5P304	Socket		1
1P850	Torque Multiplier		1

start by:

a) remove tilt cylinder

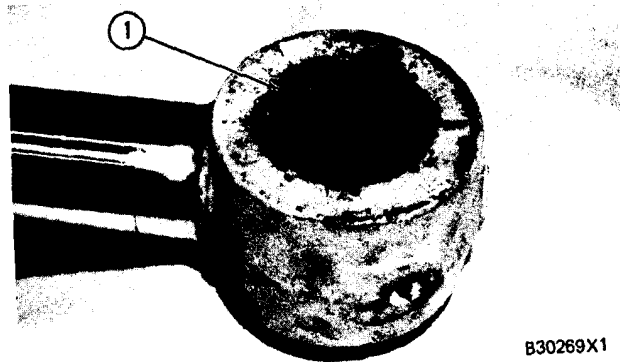

1. Remove lip type seals (1) from each end of the cylinder.

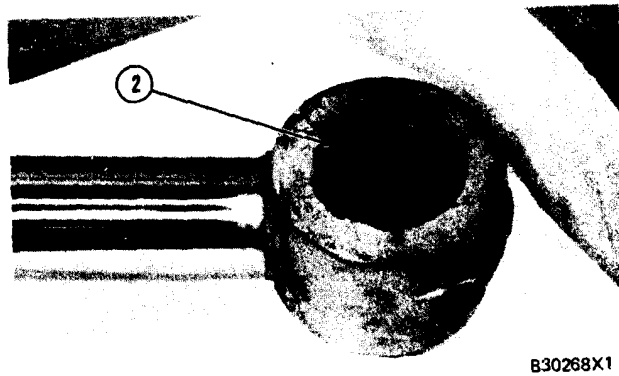

2. Remove bearings (2) from each end of the cylinder.

3. Put tilt cylinder (3) in position on tooling (A) as shown.

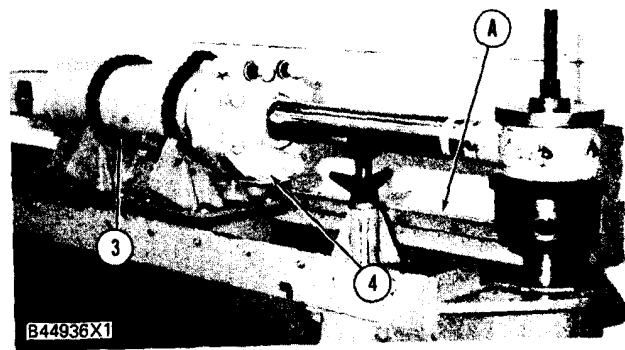

4. Make a mark on the cylinder and the head for correct assembly.

5. Remove bolts (4) that hold the head to the cylinder.

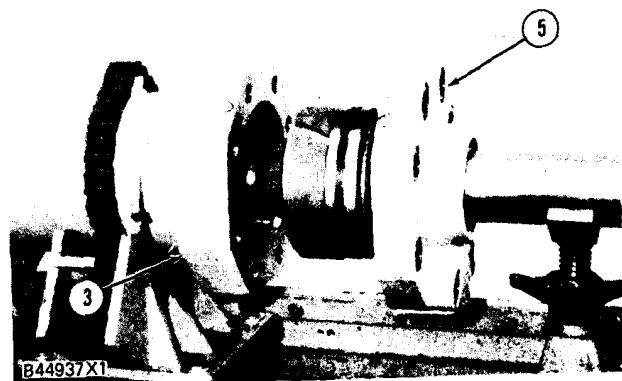

6. Use tooling (A) to make a separation of head (5) from cylinder (3).

TILT CYLINDER

7. Use tooling (B) to remove the nut from the cylinder rod.

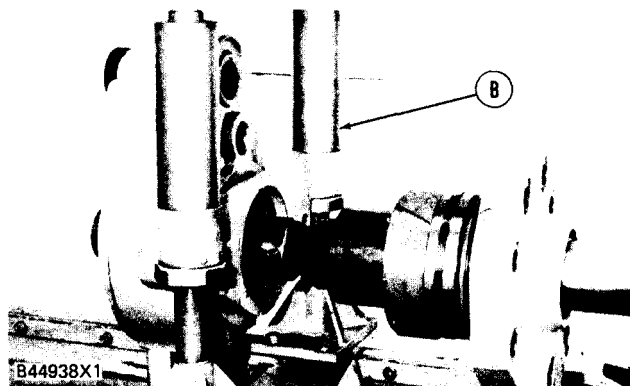

- Remove piston assembly (6) from cylinder rod (7).

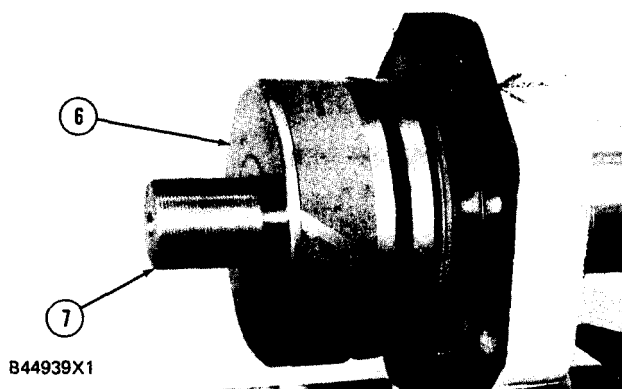

9. Remove wear ring (9) and seal (8) from the piston.

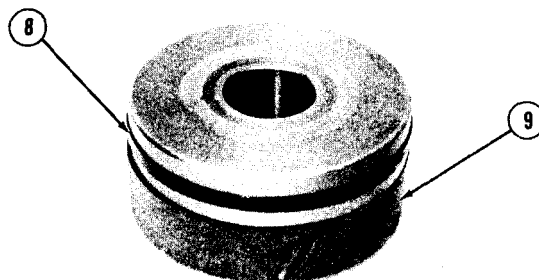

10. Put the rod and the head assembly in position on the cylinder. Install four bolts (4) as shown,

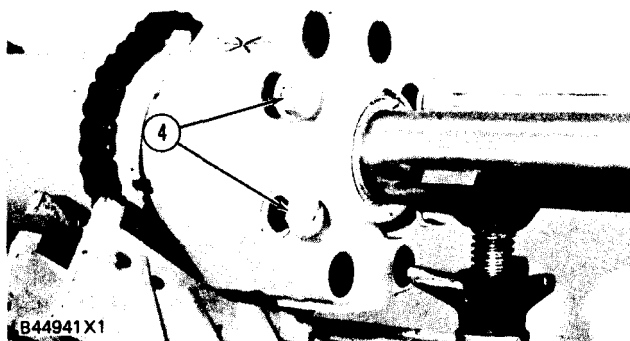

TILT CYLINDER

11. Use tooling (A) to make a separation of rod (7) from head (5).

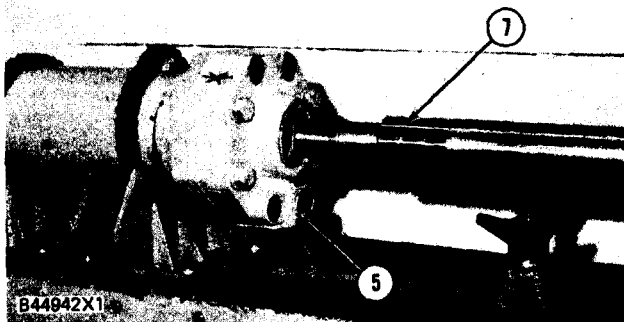

12. Remove bolts (4) and head (5) from the cylinder. The weight of the head is 27 kg (60 lb.).

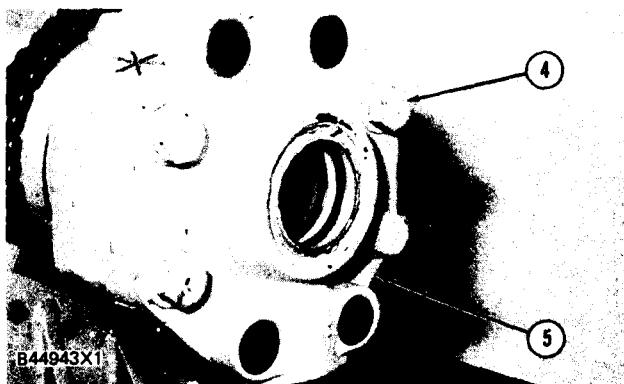

13. Remove O-ring seal (10) and backup ring (11) from the head.



14. Remove seals (12), (13) and (14) from the head.

NOTE: Models 950BSCE and 950BNSCE are equipped with a wear ring models 950BS and 950 BNS are not.

15. For Models 950BNSCE and 950BSCE only, remove wear ring (15).

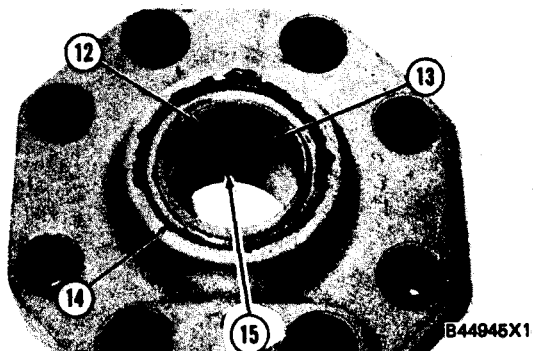

TILT CYLINDER

ASSEMBLE TILT CYLINDER

5104-15

Tools Needed		A	B	C	D	E	F
1P520	Driver Group	1					
6V4948	Hydraulic Cylinder Repair Stand	1					
5P3100	Pump Group (or electric)	1				1	
1P772	Rod Seal Guide	1					
4S9181	Seal Expander	1					
6V109	Torque Multiplier					1	
1P850	Torque Multiplier					1	
5P304	Socket					1	
9S5558	Stud					1	
1P544	Nut					1	
4K684	Washer					1	
5P2998	Hydraulic Puller					1	
1P1838	Plate					1	

1. Install inner seal (4) in head (1). The inner seal does not have a lip and can be installed either way. Install middle seal (3) with the lip in. Use tooling (A) and install outer seal (2) with the lip out. Put clean oil on the seals. For models 950BNSCE and 950BSCE, install wear ring (16).
2. Install backup ring (6) and O-ring seal (5) on head (1). Make sure the backup ring is away from the oil in the cylinder.
3. Put the cylinder and rod in position on tooling (B).
4. Install head (1) on the cylinder as shown and install two bolts to hold it.

NOTE: Use two persons to install the cylinder head.

5. Put tooling (C) in position on rod (7). Use tooling (B) to install head (1) on rod (7).

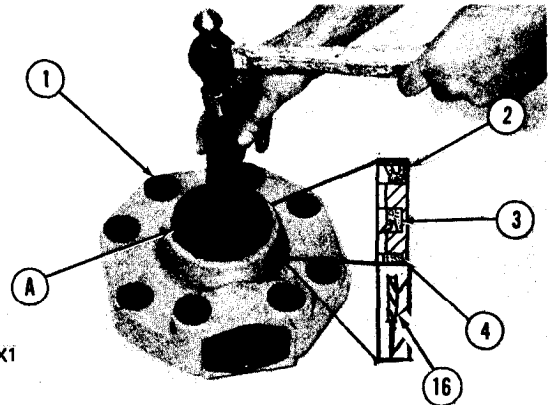

B44946X1

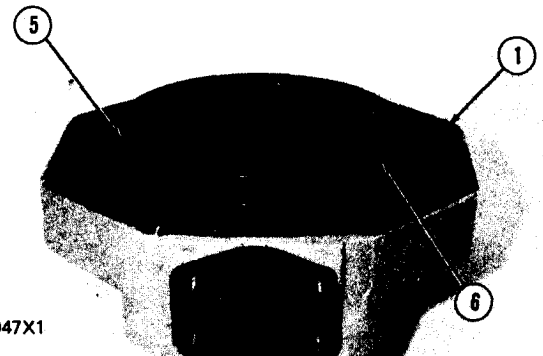

B44947X1

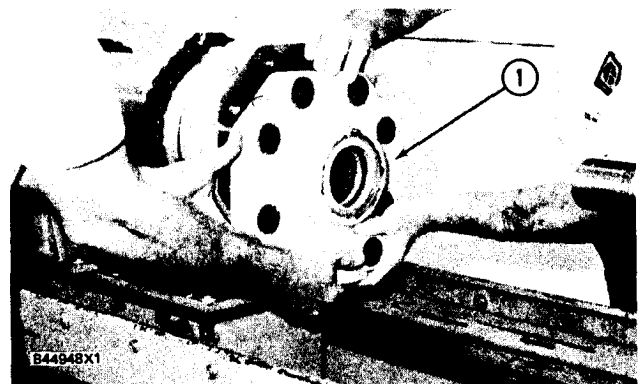

B44948X1

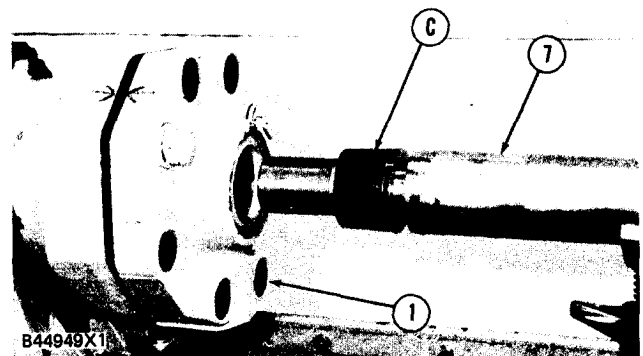

B44949X1

TILT CYLINDER

CAUTION

Do not make seal (8) any larger than is necessary for installation.

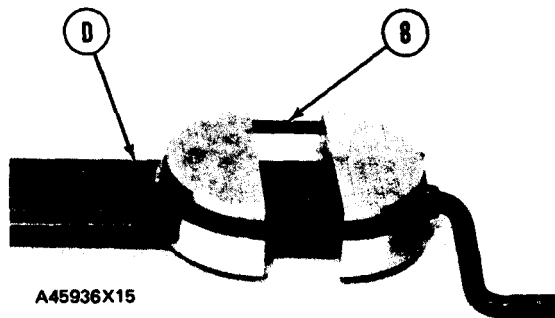

6. Use tool (D) to make an expansion of plastic seal (8) that is part of seal assembly.

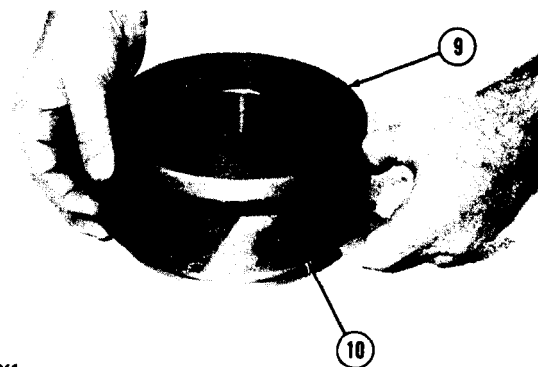

7. Install the seal assembly and wear ring (10) on piston (9). Put lubricant on the seals.

8. Put piston (9) in position on the cylinder rod.

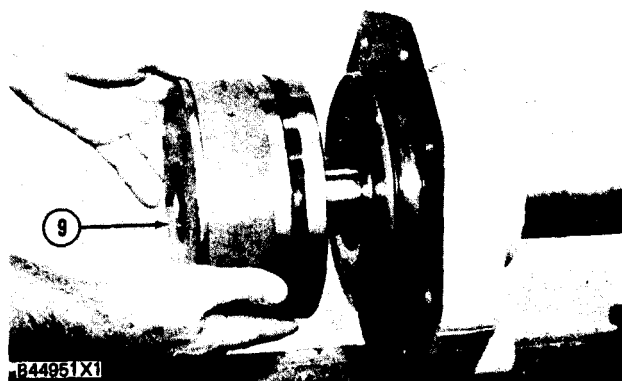

9. Put oil on the threads of the rod end.

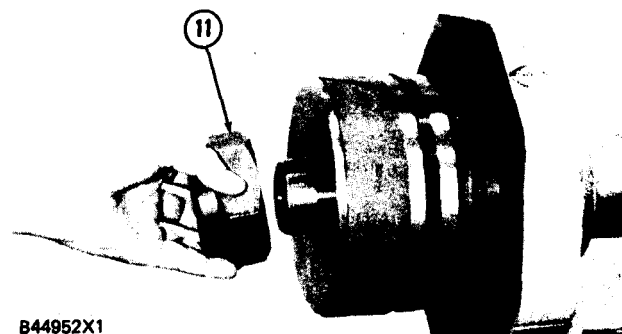

10. Install nut (11) on the end of the cylinder rod.

TILT CYLINDER

10. Put tooling (E) in position on the nut. Tighten the nut to a torque of $3100 \pm 310 \text{ N}\cdot\text{m}$ ($2290 \pm 229 \text{ lb. ft.}$).

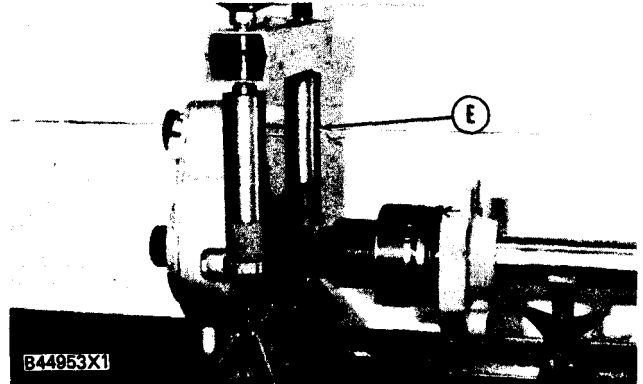

11. Use tooling (B) to install cylinder (12) on rod assembly (13).

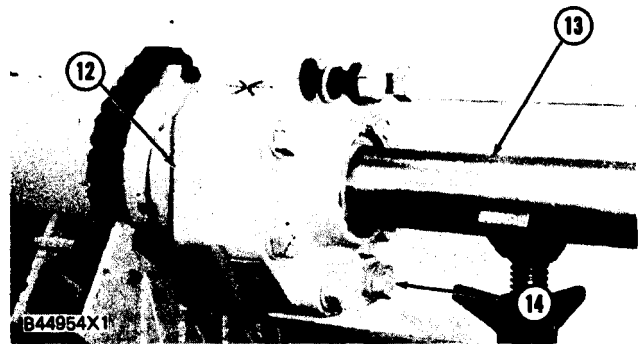

NOTE: The cylinder rod must be fully extended when bolts (14) are tightened. This will keep the cylinder piston and head in alignment with each other.

12. Install bolt (14) that holds the head to the cylinder.

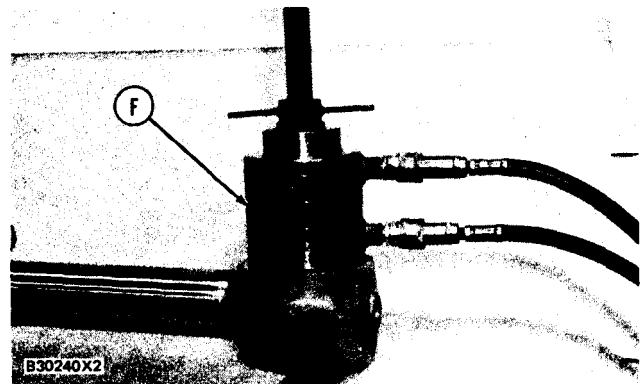

13. Lower the temperature of the bearings and install them in the center of the bores with tooling (F).



14. Install lip type seal (15) with tooling (A). The lip of the seal must be toward the outside end by:
a) install tilt cylinder

LIFT CYLINDERS

REMOVE LIFT CYLINDERS

5102-11

Tools Needed		A	B	C	D
8S7630	Stand	2			
8S7641	Tube	2			
8S7615	Pin	2			
8S8048	Saddle	2			
5P3100	Pump Group (or electric)		1	1	1
6V3175	Hydraulic Puller		1	1	1
9S5558	Stud, 1 ¼ in.		1	1	1
4K684	Washer		1	1	1
1P544	Nut		1	1	1
9S5433	Adapter		2		
5P9736	Link Bracket		2		
6V86	Adapter			1	
1P1837	Plate				1
9S5431	Sleeve Assembly		1		1

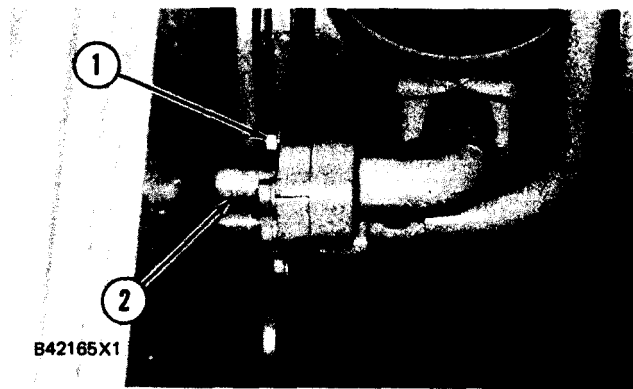
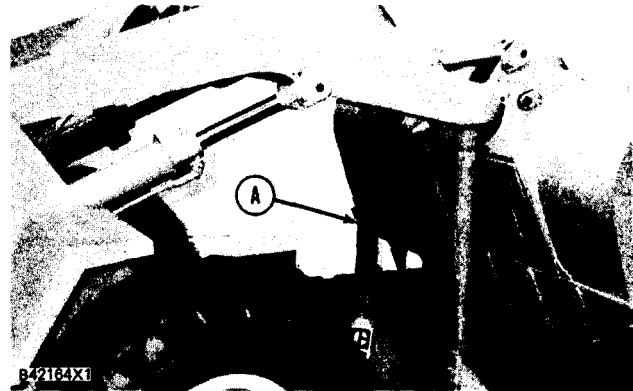

1. Use the machine hydraulic system to put the loader frame in position on tooling (A) as shown.

2. Drain the oil from the hydraulic tank.

3. Remove bolts (1) and disconnect two lines (2) on each side.

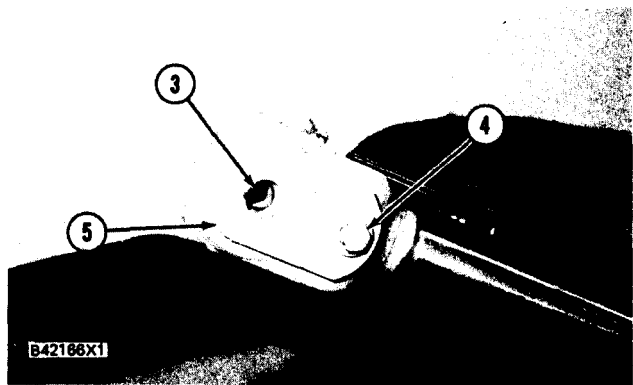

4. Remove grease fittings (3), bolts (4), the spacers and washers from pin (5).

5. Put tooling (B) in position on pins (5). Fasten a hoist to tooling (B) and one to the lift cylinder so they do not fall when the pin is removed.

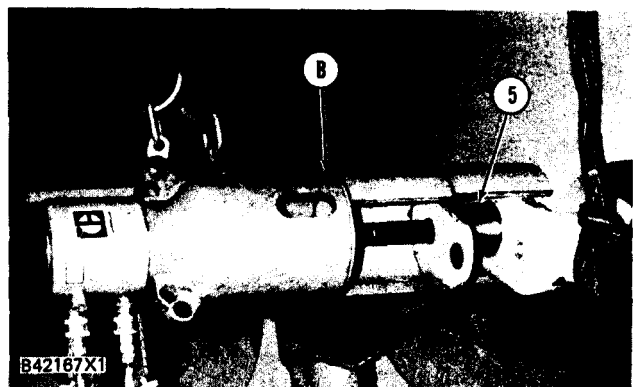

6. Remove pins (5).

LIFT CYLINDERS

Remove grease fittings (7) and bolts (6) from pins (8).

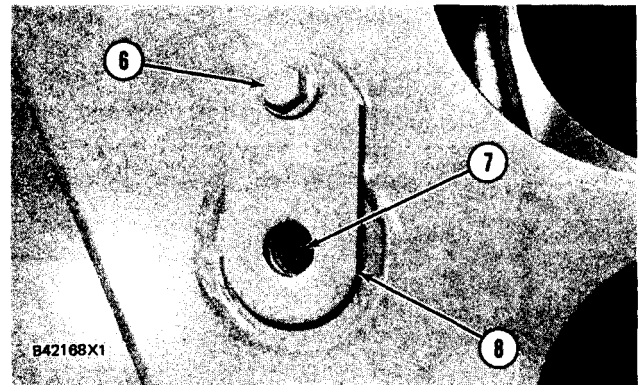

8. Install tooling (C) on pins (8). Fasten two hoists on each end of the cylinders and one on tooling (C) so they do not fall when pins (8) are removed. Remove pins (8).



9. Remove lift cylinders (9) from the machine. The weight of the lift cylinder is 150 kg (330 lb.).

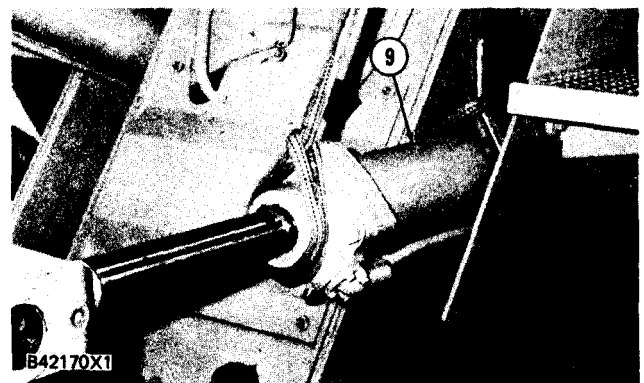

10. Install tooling (D) on the bearings. Fasten a hoist to tooling (D) so it does not fall when the bearings are removed. Remove the bearings.

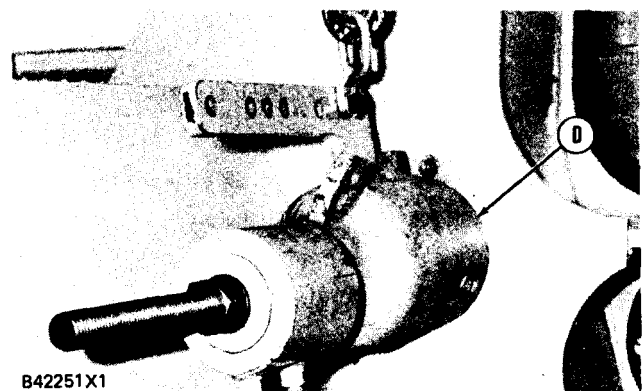

LIFT CYLINDERS

INSTALL LIFT CYLINDERS

5102-12

Tools Needed		A	B
6V3175	Hydraulic Puller	1	
1P544	Nut	1	
4K684	Washer	1	
5P3100	Pump Group (or electric)	1	
1P1837	Plate	1	
8S7650	Stand		2
8S7641	Tube		2
8S7615	Pin		2
8S8048	Saddle		2

1. Lower the temperature of the bearings and install them with tooling (A) in the center of their bores.

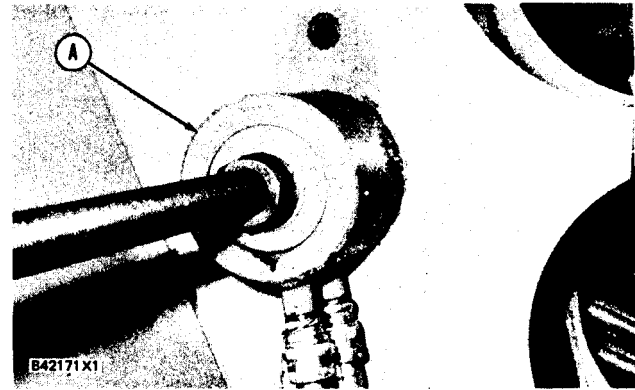

NOTE: Put 5P960 Multipurpose Type Grease in the bores of the cylinders and on the pins.

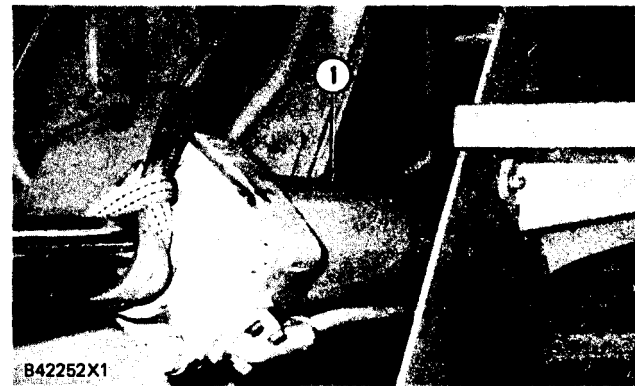

2. Fasten a hoist to lift cylinders (1) and put them in position on the machine.

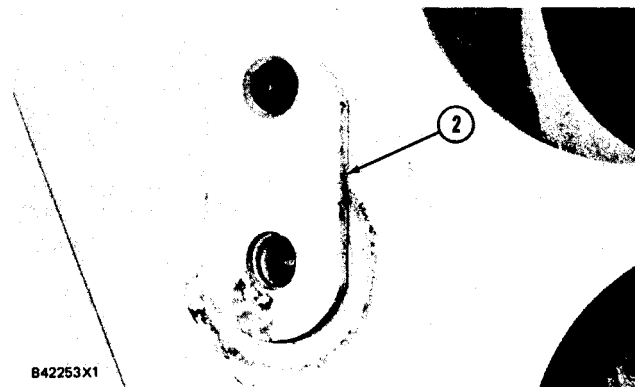

3. Install pins (2) in the frame and lift cylinders.

4. Install the spacers, washers and bolts (3) that hold pins (2) in place.

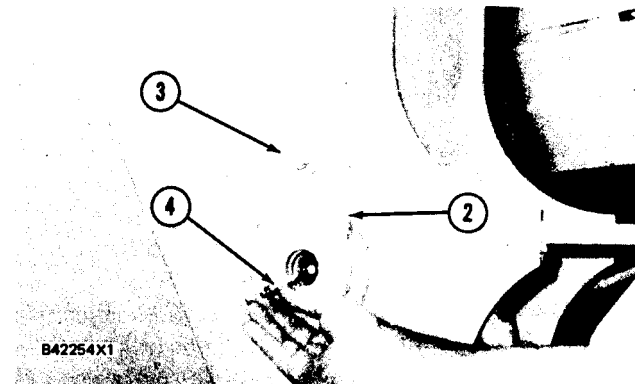

5. Install grease fittings (4) in pin (2).

LIFT CYLINDERS

6. Install rod end pins (5) in the loader frame.



7. Install the spacers, washers and bolts (6) that hold pins (5) in place.

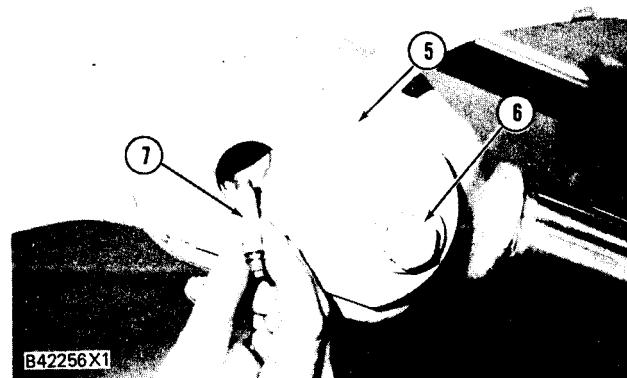

8. Install grease fittings (7) in pins (5).

9. Make sure the O-ring seals are in position in the oil lines. Connect oil lines (8) to cylinder.

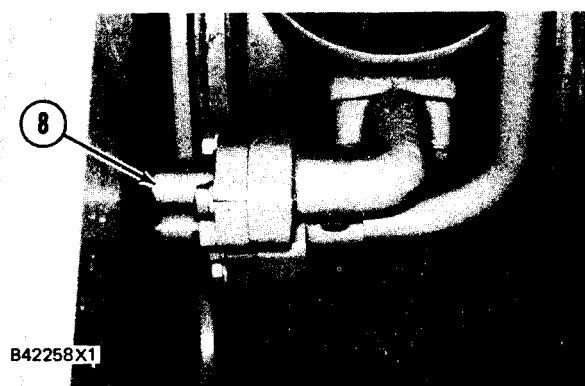

10. Fill the hydraulic system with oil to the correct level.

11. Lift the loader frame and remove tooling (B) from under the machine.

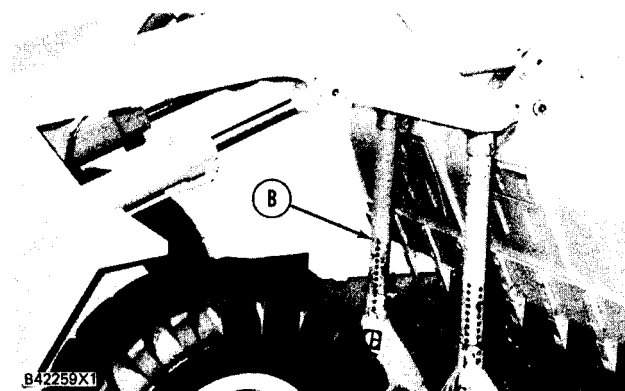

LIFT CYLINDERS

DISASSEMBLE LIFT CYLINDERS 5102-15

Tools Needed		A	B
6V4947	Hydraulic Cylinder Repair Stand 1		
6V109	Torque Multiplier		1
1P850	Torque Multiplier		1
5P303	Socket		1

start by:

a) remove lift cylinders

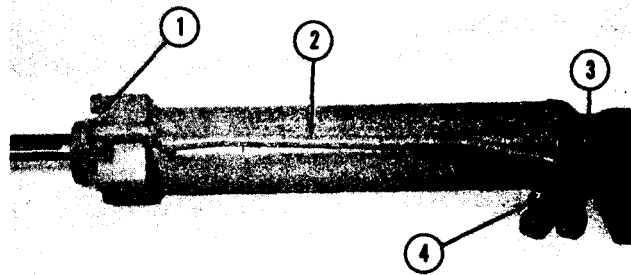

B42268X1

1. Remove bolts (1), (3) and tube assemblies (2) and (4) from the lift cylinders.

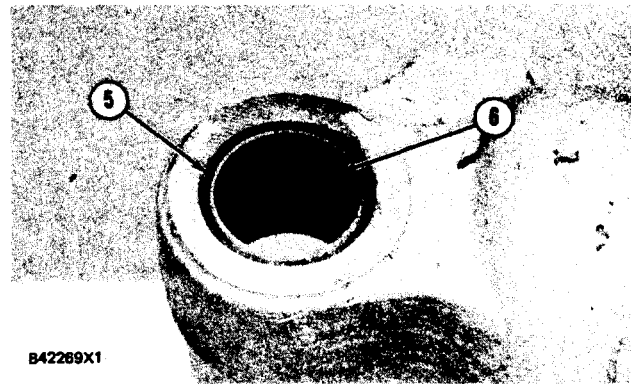

B42269X1

2. Remove two lip type seals (5) and bearing (6) from the cylinders.

3. Put lift cylinders (7) in position on tooling (A).

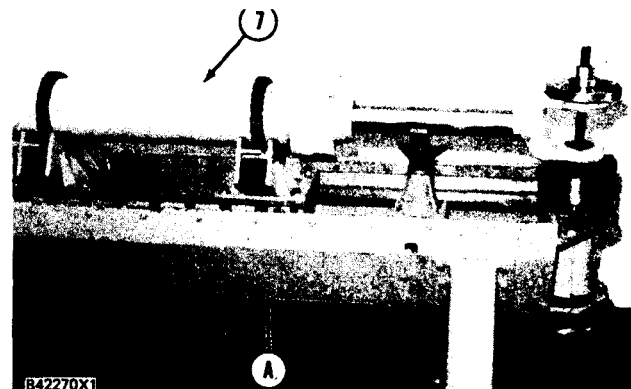

B42270X1

4. Remove bolts (8) that hold the head to the cylinder.

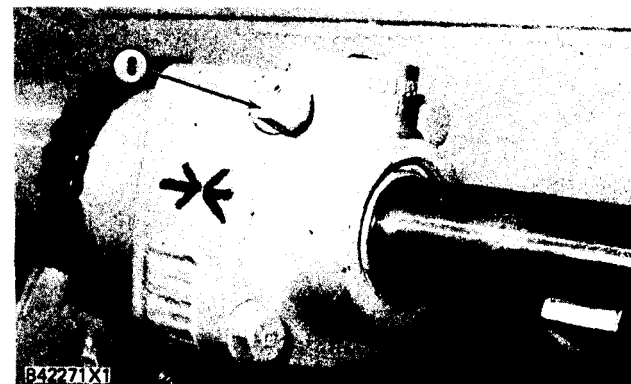

B42271X1

5. Use tooling (A) to make a separation of the head and cylinder.

LIFT CYLINDERS

6. Put tooling (B) in position and remove the nut from the cylinder rod.

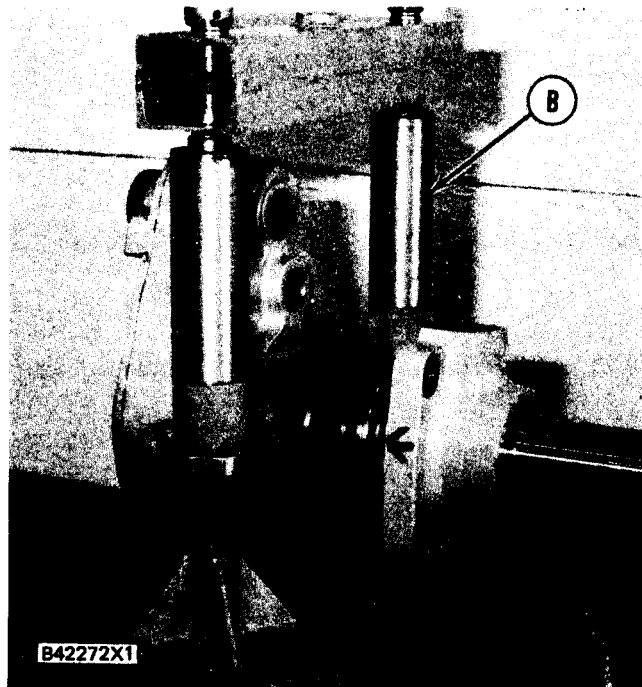

7. Remove piston assembly (9) from the rod.

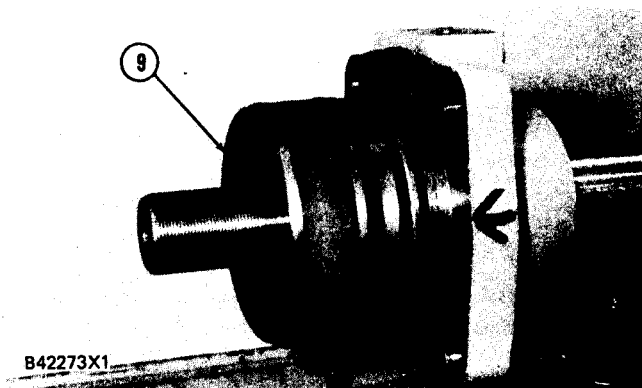

8. Remove seal assembly (10) and wear ring (11) from the piston.

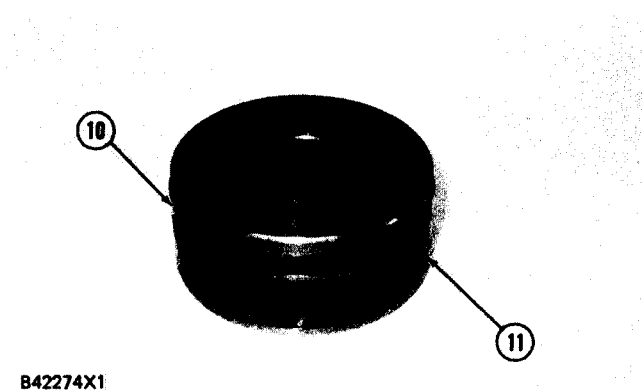

LIFT CYLINDERS

9. Use tooling (A) to make a connection of the cylinder and head.

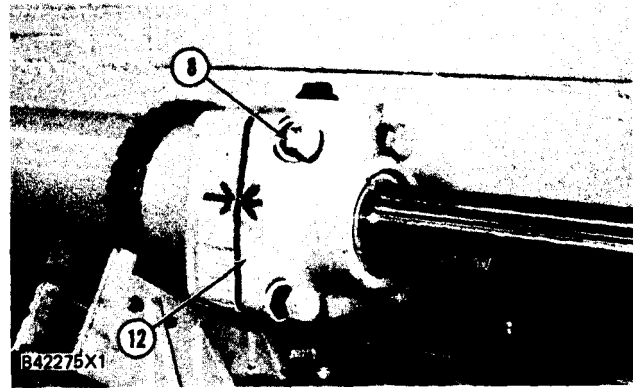

10. Install bolts (8) to hold the cylinder and head together.

11. Use tooling (A) to pull head (12) off rod (13).

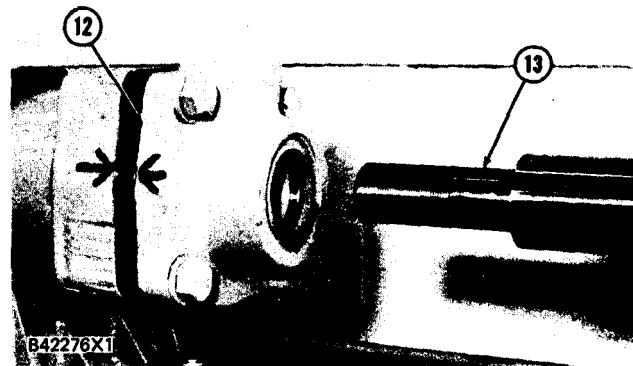

12. Remove O-ring seal (14) and backup ring (15) from the head.

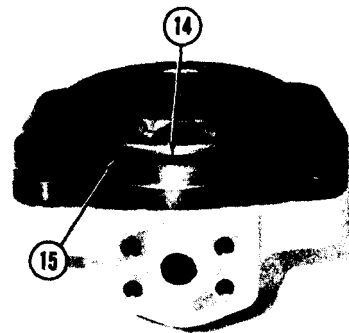

13. Remove lip type seal (16) from the head

14. Remove seal rings (17) from the head.

NOTE: Models 950BSCE and 950BNSCE are with a wear ring. Models 950BS and 950BNS are not.

15. For models 950BNSCE and 950BSCE only, remove wear ring (18).

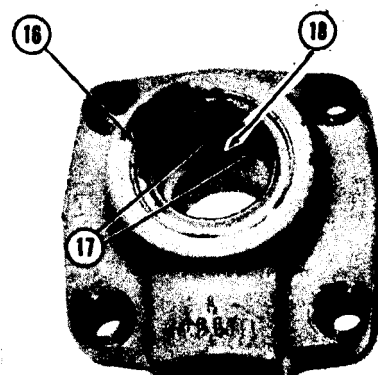

LIFT CYLINDER

B45330X1

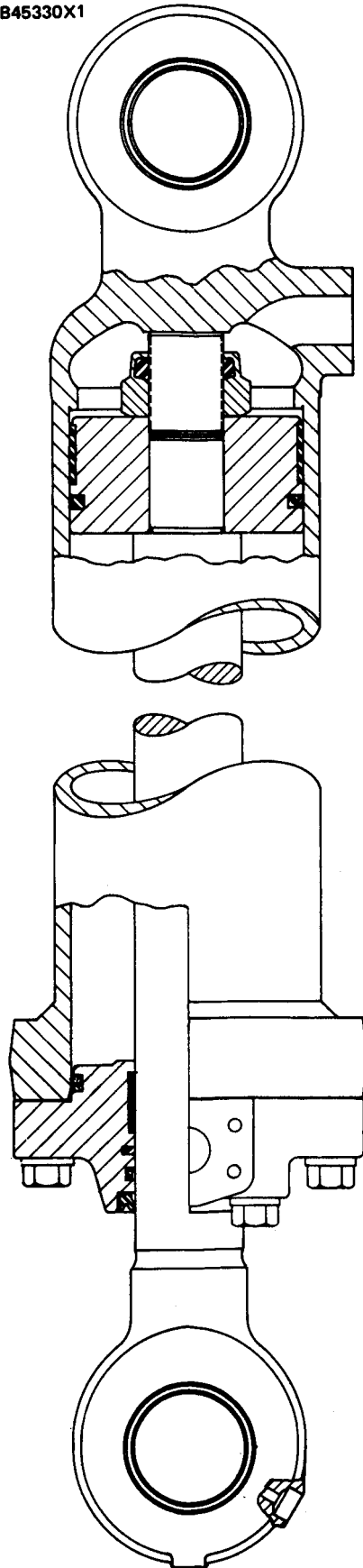

LIFT CYLINDERS

ASSEMBLE LIFT CYLINDERS

5102-16

Tools Needed		A	B	C	D	E	F
1P510	Driver Group	1					
6V4947	Hydraulic Cylinder Repair Stand		1				
5P5191	Seal Guide			1			
4S9181	Expander Assembly				1		
6V109	Torque Multiplier					1	
1P850	Torque Multiplier					1	
5P303	Socket					1	
6V3175	Hydraulic Puller					1	
9S5558	Stud, 1 1/4 in.					1	
4K684	Washer					1	
7P544	Nut					1	
5P3100	Pump Group (or electric)					1	
1P1837	Plate					1	

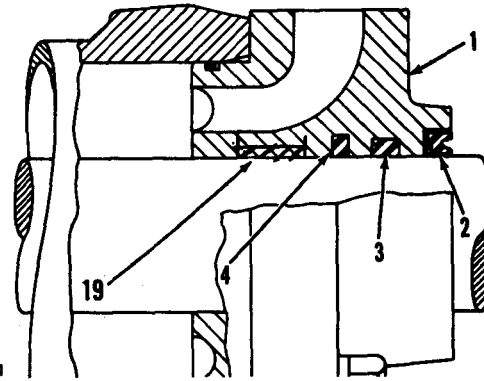

B30825X1

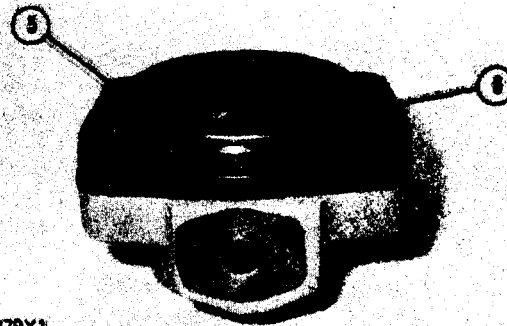

B42279X1

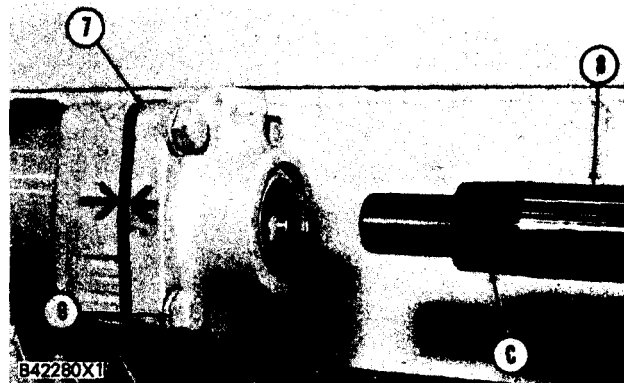

B42280X1

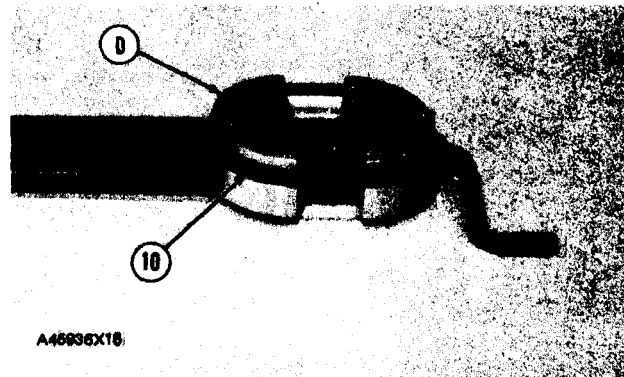

A46936X16

1. Install inner seal (4) in head (1). The inner seal does not have a lip and can be installed either way. Install middle seal (3) with the lip in. Use tooling (A) and install outer seal (2) with the lip out. Put clean oil on the seals.
- 1A. On models 950BNSCE and 950BSCE, install wear ring (19).
2. Install backup ring (6) and O-ring seal (5) on the head. The backup ring goes on the side of the O-ring seal away from the piston.
3. Put the cylinder and the rod in position on tooling (A).
4. Put cylinder head (7) in position on the cylinder and install bolts (9).
5. Put tool (C) in position on cylinder rod (8).
6. Use tooling (B) to install the rod in the head.
7. Remove the bolts and make a separation of the head and rod from the cylinder.
8. Use tool (D) to make an expansion of seal (10) which is part of the seal assembly.

LIFT CYLINDERS

9. Install seal assembly (12) and wear ring (11) on the piston.

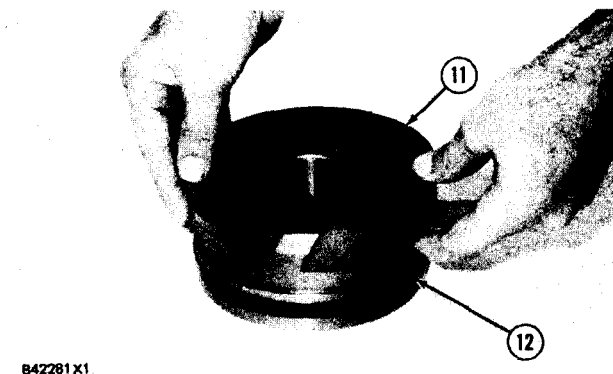

10. Install piston (14) and nut (13) on the cylinder rod.

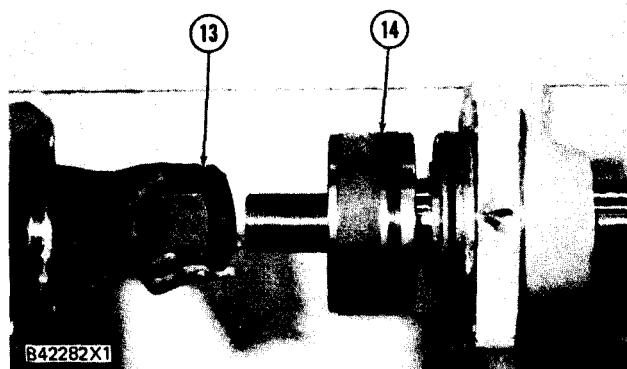

11. Put clean oil on the threads of the nut.

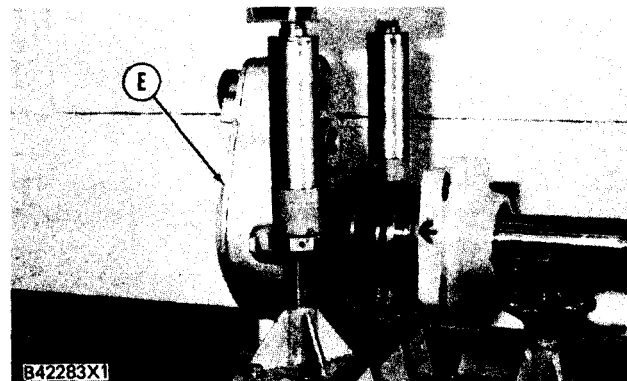

12. Use tooling (E) to tighten nut (13) to a torque of 2700 ± 270 N•m (1990 ± 199 lb.ft.).

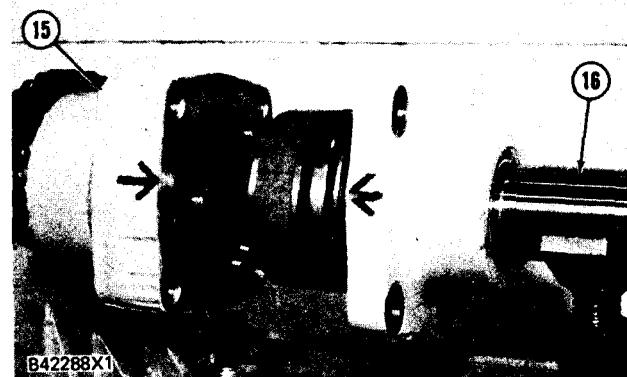

13. Use tooling (B) to put rod assembly (16) in position in cylinder (15).

LIFT CYLINDERS

14. Install bolts (17) that hold the head to the cylinder.

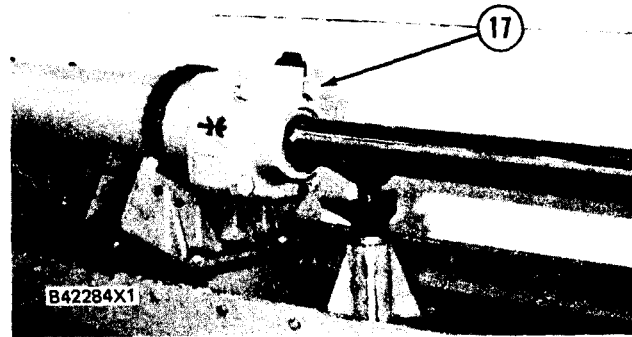

15. Install tube assemblies (18) on the lift cylinders.

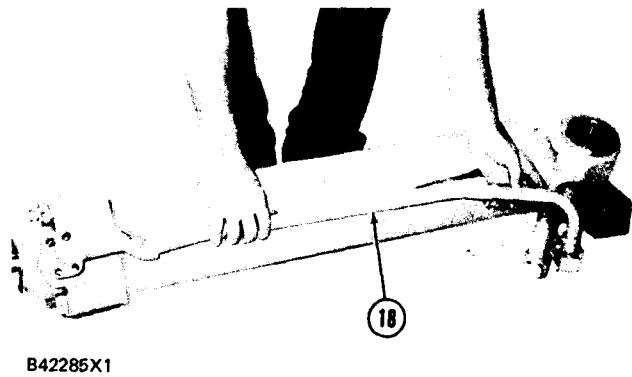

16. Lower the temperature of the bearing. Use tooling (F) to install the bearing in the center of the hoses.

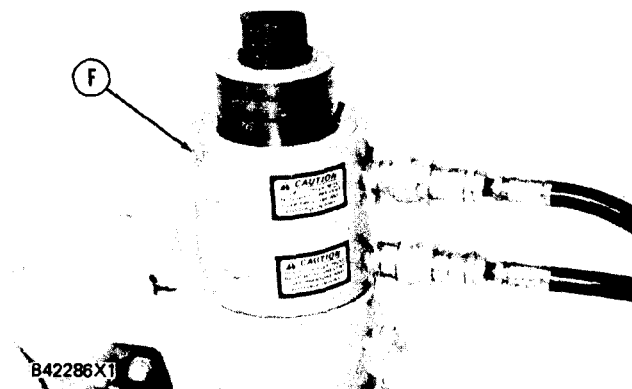

17. Put 7M7456 Bearing Mount in the bore before the seal is installed. Install the lip type seals in the bore with tooling (A). The lip of the seal must be toward the outside.

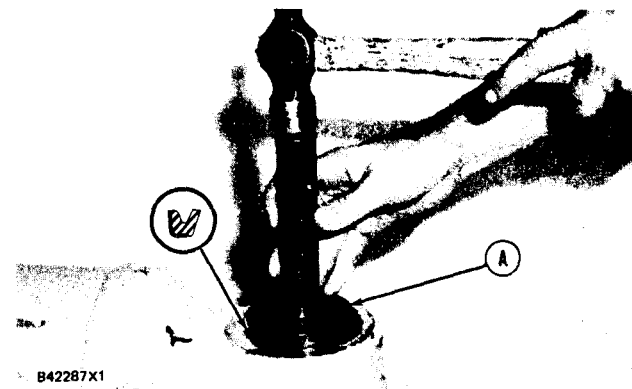

REMOVE BUCKET CYLINDERS

1. Lower bucket on two 10 inch wooden blocks and turn machine OFF.

WARNING

To prevent parsonal injury release the pressure from the hydraulic system before any lines are removed or disconnected.

2. Cycle bucket (attachment) control valve lever several times to release any hydraulic pressure in the circuit.
3. Disconnect oil line (1) from the bottom end of the cylinder (7). Plug oil line.
4. Disconnect oil line (2) from rod end of the cylinder. Plug oil line.
5. Support the cylinder with a hoist and suitable sling.
6. Remove bolt (3) and pin (4) securing the rod end of the cylinder.
7. Remove bolt (5) and pin (6) securing bottom end of cylinder. Remove the cylinder (7).

8. Follow Steps 1 through 7 to remove the other bucket cylinder.

INSTALL BUCKET CYLINDERS

1. Using a suitable sling and hoist, support the cylinder (1) in the proper mounting position as shown.
2. Put pin (2) in position at the bottom end of the cylinder and install bolt and nut (3).
3. Put pin (4) in position at the rod end of the cylinder and secure with bolt and washer (5).
4. Remove plug and connect oil line (6) to rod end of cylinder.
5. Remove plug and connect oil line (7) to bottom end of cylinder.
6. Torque cylinder mounting bolts (3 & 5) to specification. Apply grease to fittings at each end of cylinder; See Section 1, Lubrication and Maintenance.
7. Follow Steps 1 through 6 to install the other bucket cylinder.

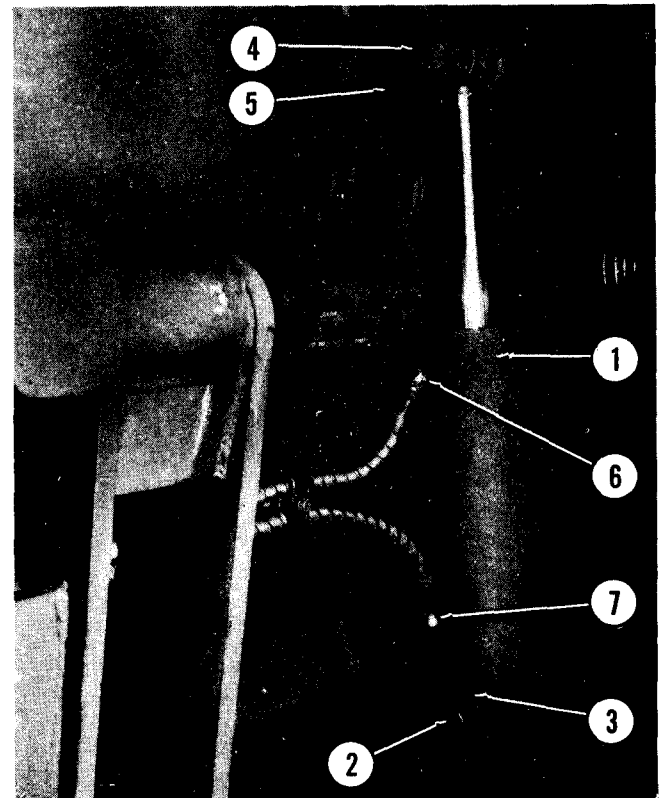
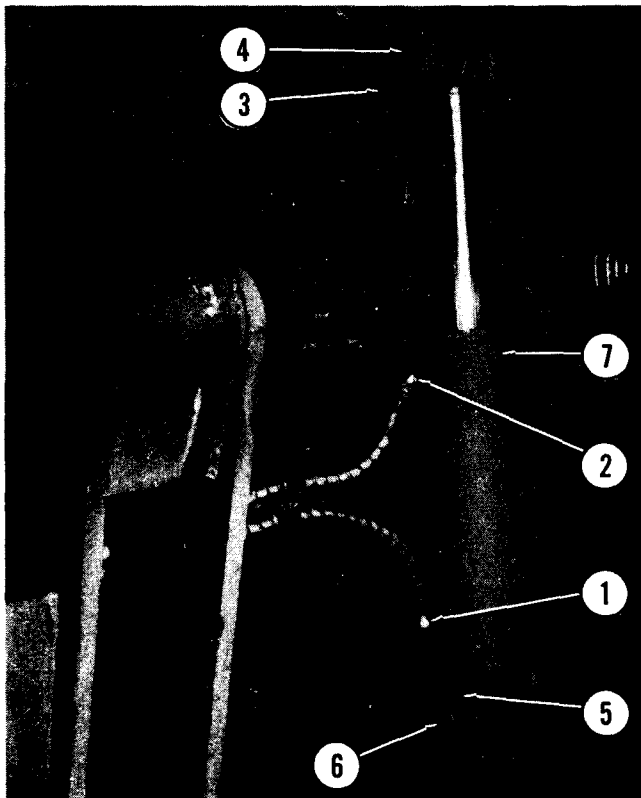

BUCKET CYLINDERS

DISASSEMBLE BUCKET CYLINDERS

start by

a) remove bucket cylinders.

1. Remove the U-ring (12), retainer (11), plug (8) and wiper (10) from the end of the tube assembly (3).
2. Separate the rod assembly (4) from the tube assembly (3).
3. Unscrew the nut (14) from the rod assembly (4).
4. Remove the piston (1), U-ring (2) and O-ring (13) from the rod assembly (4).
5. Remove the bearing (7), O-ring (5) and back-up (6) from the rod assembly (4).

ASSEMBLE BUCKET CYLINDERS

1. Install back-up (6), O-ring (5) and bearing (7) on the rod assembly (4).
2. Install the O-ring (13), U-ring (2), and piston (1) on the rod assembly (4).
3. Screw the nut (14) on the end of the rod assembly (4).
4. Slide the piston (1) and rod assembly (4) onto the tube assembly (3).
5. Install the retainer (11), U-ring (12), plug (8) and wiper (10) on the end of the tube assembly (3).

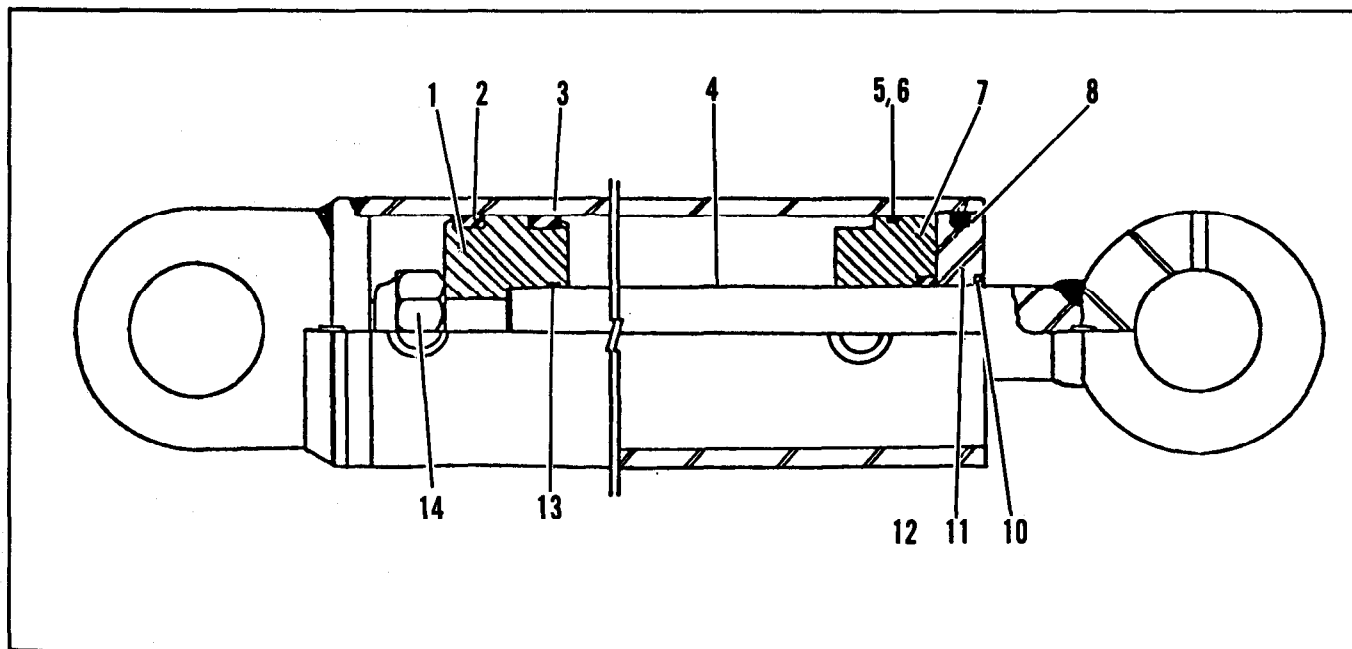

STEERING CYLINDERS**REMOVE STEERING CYLINDERS 4303-11**

start by:

- a) connection of anti-pivot link

WARNING

To prevent personal injury release the pressure from the hydraulic system before any lines are removed or disconnected.

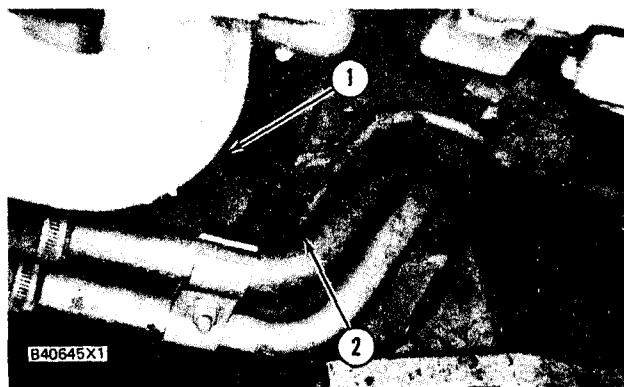

1. Disconnect grease line (2) and oil line (1) from the rear of the steering cylinder.
2. Disconnect oil line (3) from the rod end of the steering cylinder.

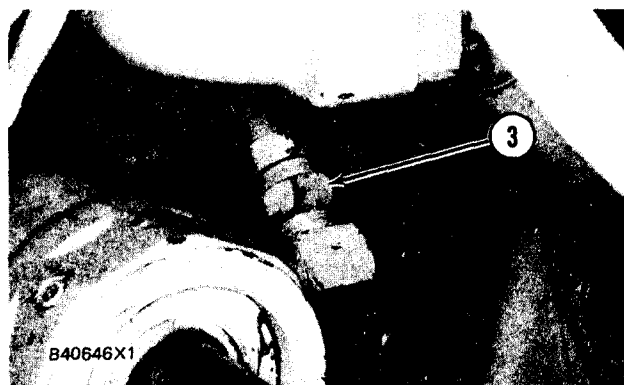

Remove bolt (5), the spacer and pin (4) from the rod end of the steering cylinder.

4. Remove bolt (6), the spacer and pin (7) from the rear of the steering cylinder.
5. Put steering cylinder (8) in position as shown. Use two persons and remove the cylinder toward the rear (engine end) of the machine. The weight of the steering cylinder is 41 kg (90 lb.).
6. Follow Steps 1 through 5 to remove the other steering cylinder.

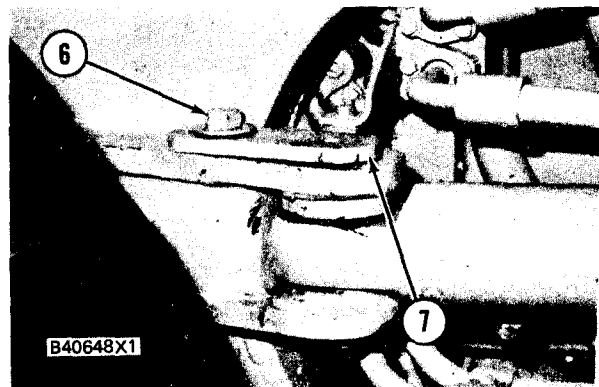
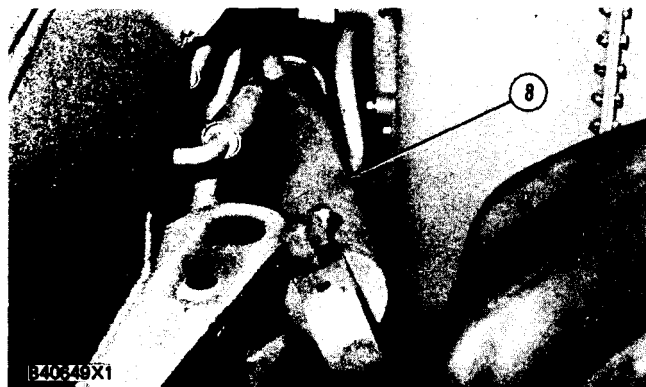
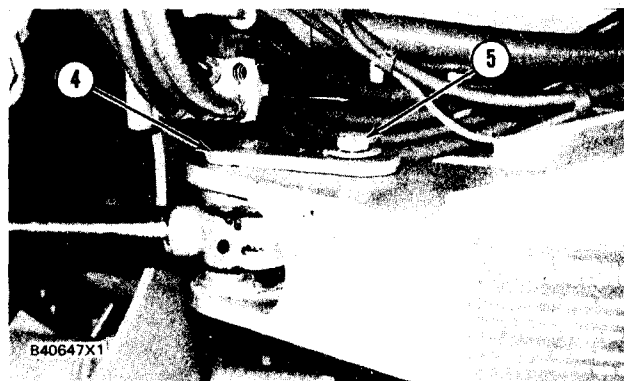

STEERING CYLINDERS

INSTALL STEERING CYLINDERS 4303-12

1. Install steering cylinder (1) as shown.

2. Put pin (3) in position and install spacer (4) and bolt (2) that hold the pin in place.

3. Put pin (5) in position and install spacer (7) and bolt (6) that hold the pin in place.

4. Connect oil line (8) to the rod end of the cylinder.

5. Connect oil line (9) and the grease line to the rear of the steering cylinder.

6. Follow Steps 1 through 5 to install the other steering cylinder end by:
 - a) separation of anti-pivot link

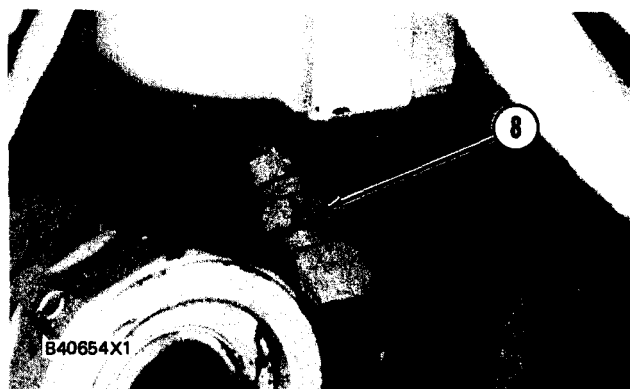
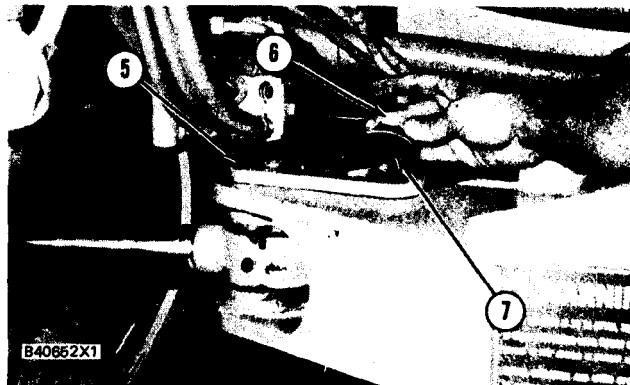
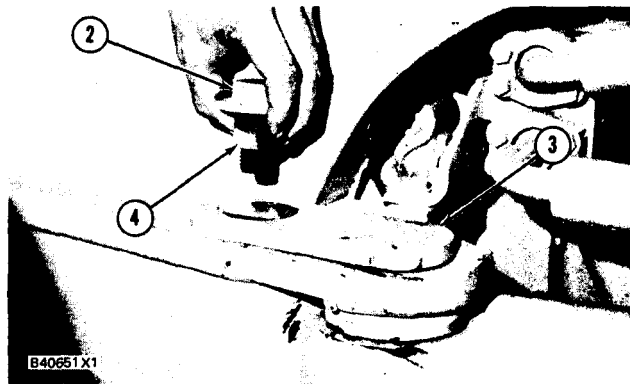
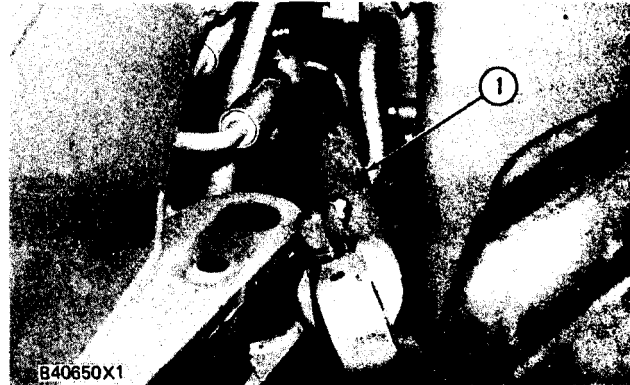

STEERING CYLINDER

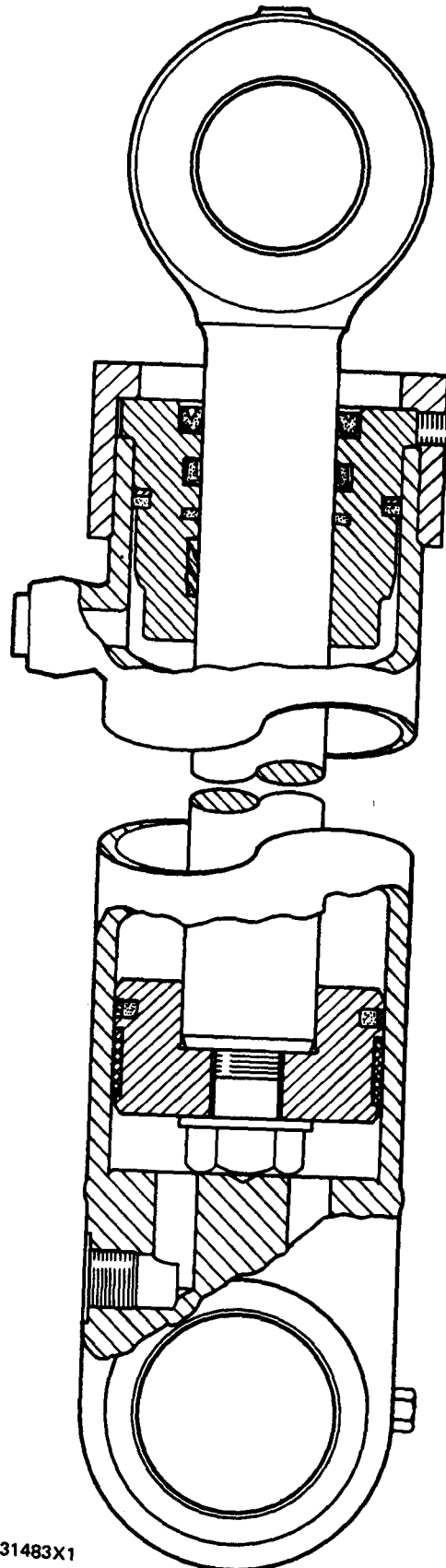

B31483X1

5-375

STEERING CYLINDERS

DISASSEMBLE STEERING CYLINDERS

4303-15

Tools Needed		A	B	C
1P1833	Bearing Puller Adapter	1		
9S5559	Stud, 1 in.	1		
6V3160	Hydraulic Puller	1		
1P543	Nut	1		
5F7353	Washer	1		
5P3100	Pump Group (or electric)	1		
6V4948	Hydraulic Cylinder Repair Stand		1	
8F2243	Wrench			1

start by:

a) remove steering cylinders

1. Remove seals (1) from each side and both ends of the steering cylinders.

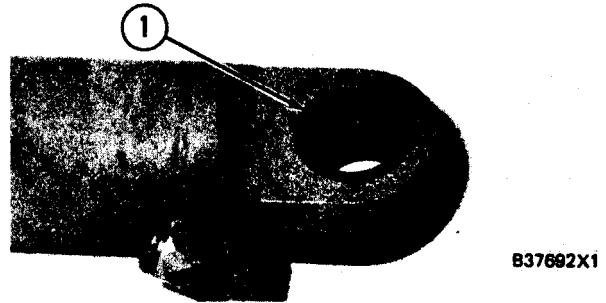

2. Use tooling (A) to remove the bearings from both ends of the steering cylinders.

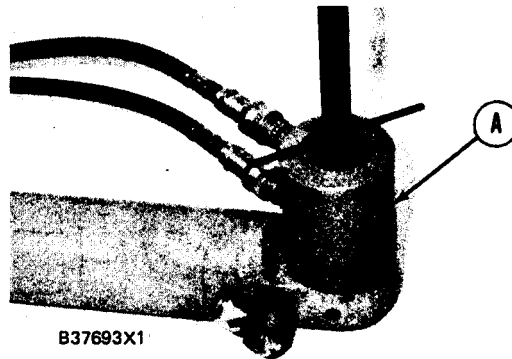

3. Put steering cylinder (2) in position on tooling (B).

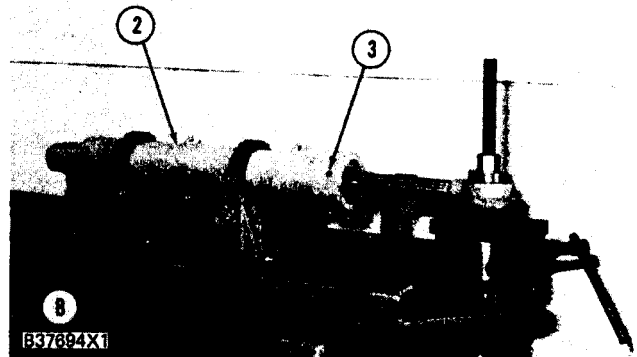

4. Remove setscrew (3) from the steering cylinder.

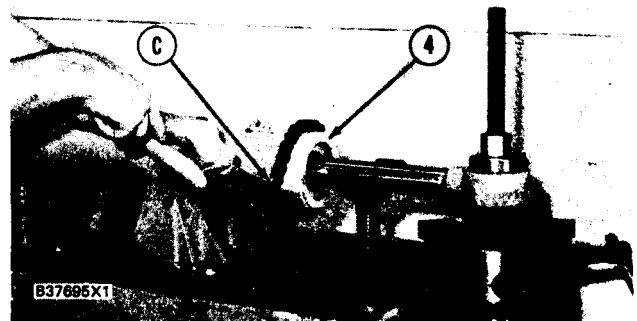

5. Use tool (C) to remove crown (4) from the steering cylinder.

VEHICLE SYSTEMS

STEERING CYLINDERS

6. Use tooling (B) to pull cylinder (2) away from the head and rod.
7. Remove nut (5), the washer, piston (6) and head (7) from the cylinder rod.
8. Remove seal assembly (9) and wear ring (8) and the piston.
9. Remove seal (11) and backup ring (10) from the head.
10. Remove lip type seals (12) and (13) from the head.
11. Remove seal ring (14) from the head.
12. On models 950BSCE and 950BNSCE remove wear ring (15) from head.

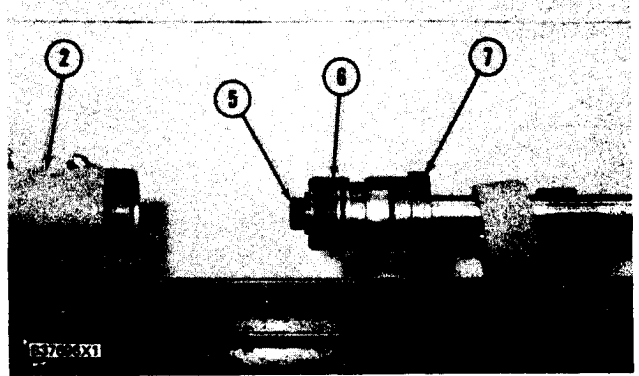

ASSEMBLE STEERING CYLINDERS 4303-16

Tools Needed		A	B	C	D	E	F
1P510	Driver Group	1					
4S9181	Seal Expander	1					
6V4948	Hydraulic Cylinder Repair Stand	1					
1P850	Torque Multiplier					1	
1P851	Spline Adapter					1	
1P852	Male Adapter					1	
1P1833	Bearing Puller Adapter					1	
9S5559	Stud, 1 in.					1	
6V3160	Hydraulic Puller					1	
1P543	Nut					1	
5F7353	Washer					1	
5P3100	Pump Group (or electric)					1	
8F2243	Wrench					1	

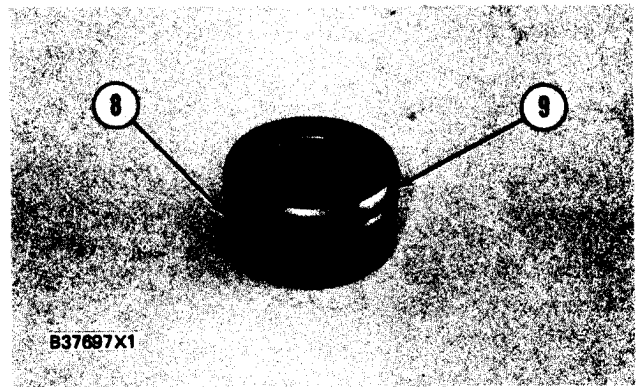

1. Clean and inspect all parts. Make a replacement of all parts that are worn or damaged.
2. Install inner seal (4) in head (1). The inner seal does not have a lip and can be installed either way. Install middle seal (3) with the lip in. Use tooling (A) and install outer seal (2) with the lip out. Put clean oil on the seals.
- 2A. On models 950BSCE and 950BNSCE install wear ring (15).

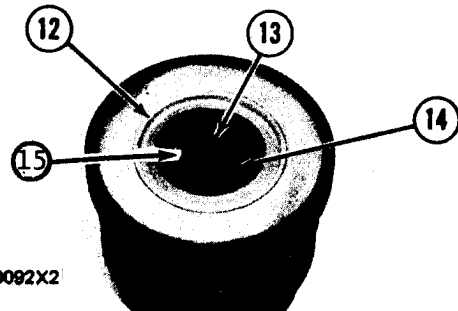
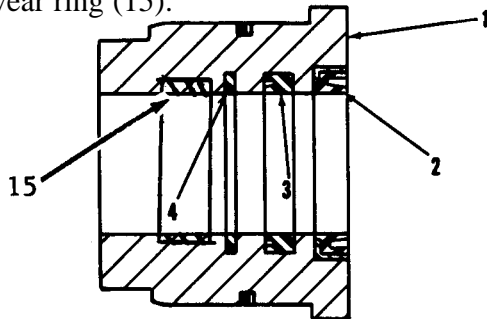
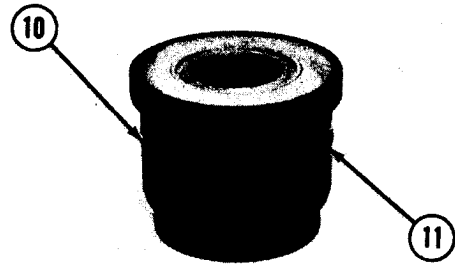

STEERING CYLINDERS

3. Install backup ring (6) and O-ring seal (5) on the head.



B30093X1

4. Use tool (B) to cause expansion of seal (7) that is a part of the seal assembly.

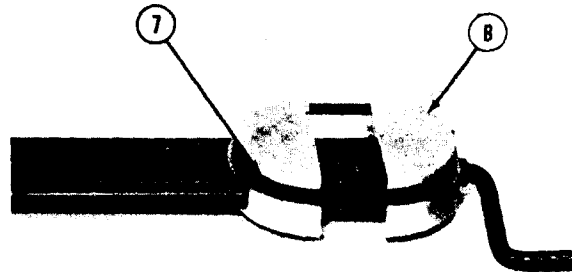

A46936X13

5. Install seal assembly (9) and wear ring (8) on the piston.

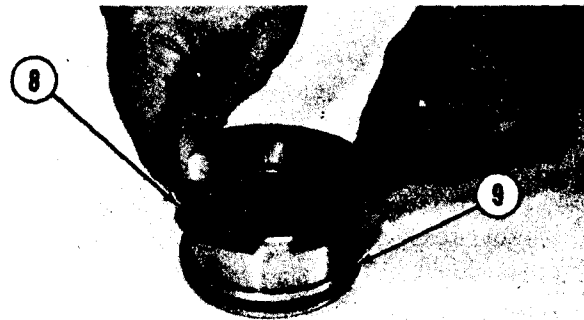

B37698X1

6. Put the cylinder and rod on tooling (C).

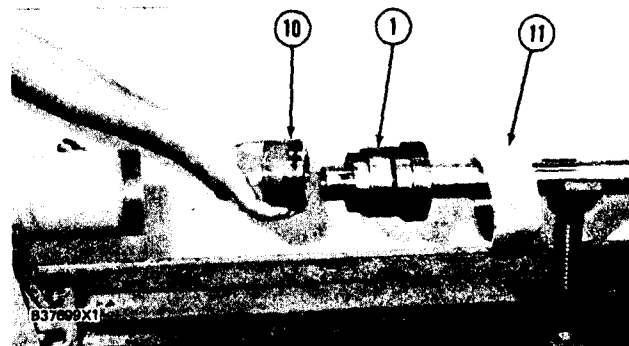

B37699X11

7. Put crown (11), head (1) and piston (10) in position on the rod.

STEERING CYLINDERS

- 8 Put clean oil on the threads of the bolt that holds the piston in place.

- 9 Install the bolt and use tooling (D) to tighten the bolt to a torque of $1080 \pm 108 \text{ N}\cdot\text{m}$ ($800 \pm 80 \text{ lb}\cdot\text{ft}$).

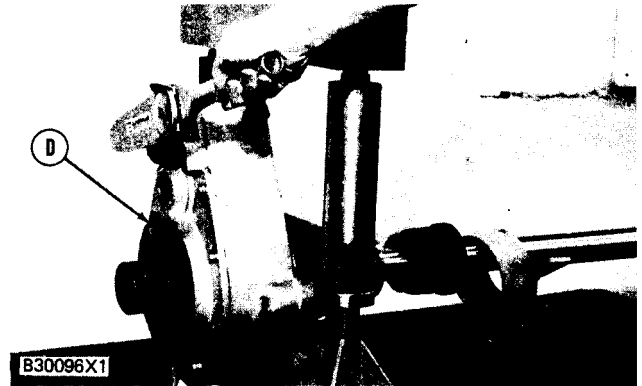

- 10 Put 5P960 Multipurpose Type Grease on the threads of cylinder (12) and the inside diameter of crown (11).

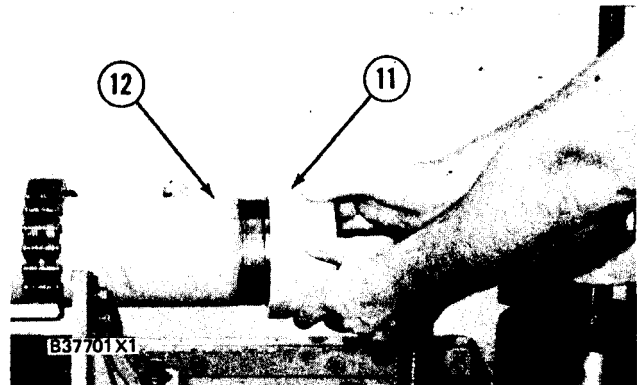

- 11 Install crown (11) on the cylinder. Use tooling (F) to tighten the crown to a torque of $475 + 270-0 \text{ N}\cdot\text{m}$ ($350 + 200-0 \text{ lb}\cdot\text{ft}$).

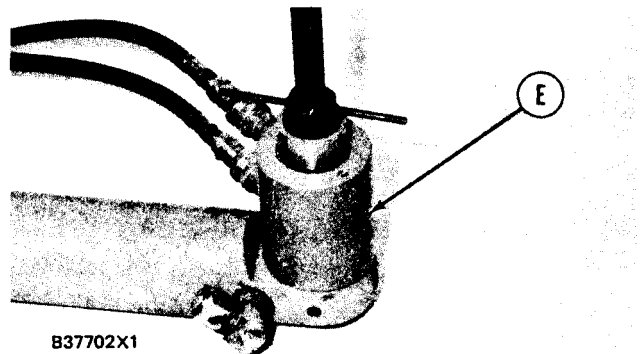

- 12 Put 9S3263 Thread Lock on the threads of the setscrew. Install the setscrew in the crown. Do not tighten the setscrew too tight because it can put a side load on the crown and the head and cause damage to the cylinder rod.

- 13 Lower the temperature of the bearings and install them in the center of the bores with tooling (E).

- 14 Use tooling (A) to install the lip type seals in the bores. The lip of the seal must be toward the outside end by:

a) install steering cylinders

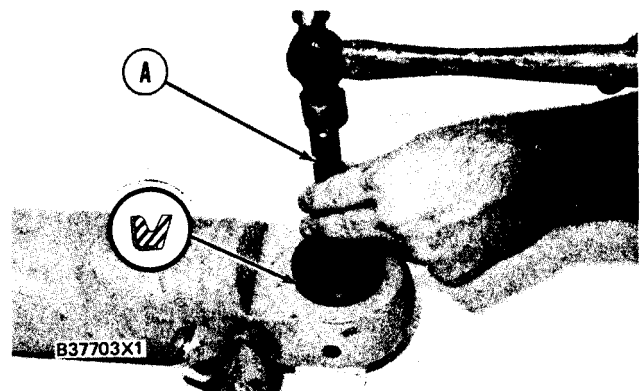

STEERING NEUTRALIZER VALVES

REMOVE STEERING NEUTRALIZER VALVES

4330-11

WARNING

To prevent personal injury release the pressure from the hydraulic system before any lines are removed or disconnected.

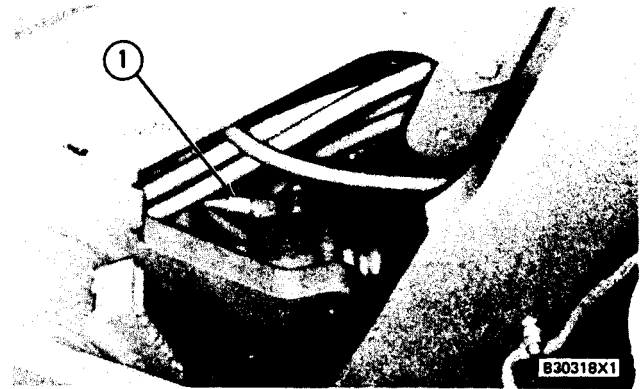

1. Disconnect lines (1) from the valve.

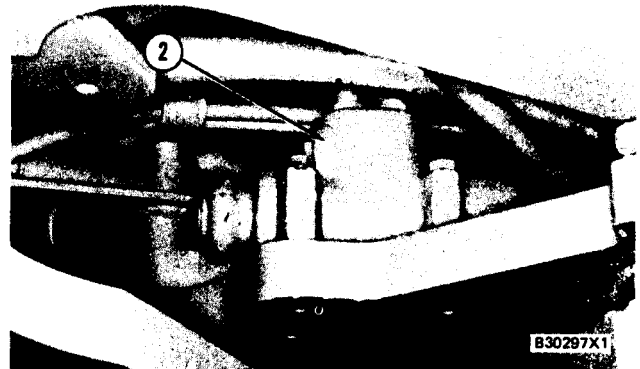

2. Remove three bolts and steering neutralizer valve (2).

INSTALL STEERING NEUTRALIZER VALVES

4330-12

1. Put neutralizer valve (1) in position and install the bolts.

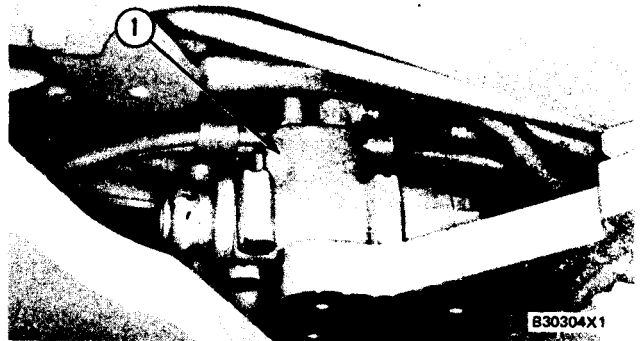

2. Connect lines (2) to the valve.

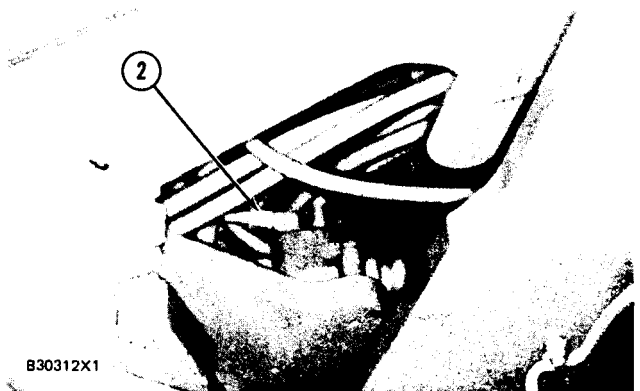

3. To check the adjustment of the striker, see NEUTRALIZER VALVE, TESTING AND ADJUSTING.

STEERING NEUTRALIZER VALVES

DISASSEMBLE STEERING NEUTRALIZER VALVES 4330-15

start by:
a) remove steering neutralizer valves

1. Remove boot (1) from valve body (2).

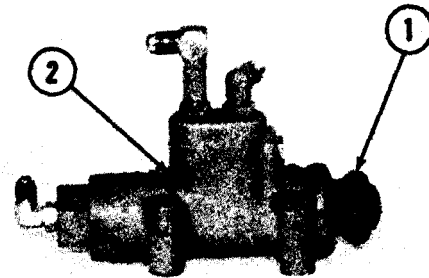

B10732X1

2. Remove plug (3) and O-ring seal (4).

3. Remove spring (5) and valve spool (6) from the valve body.

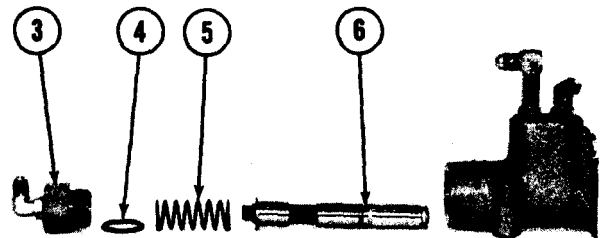

B13216X1

4. Remove bolt (7), lockwasher and washer from the spool.

5. Remove plug (11) and O-ring seal (10).

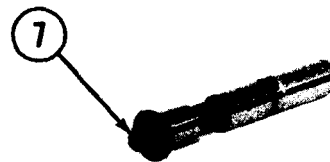

6. Remove spring (9) and ball (8) from the valve body.

7. Remove lip type seal (12) from the valve body.

B13217X1

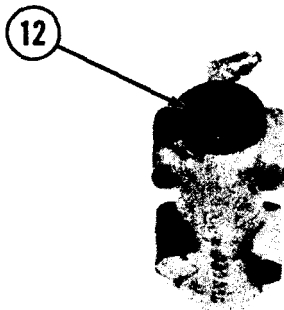

B13221X1

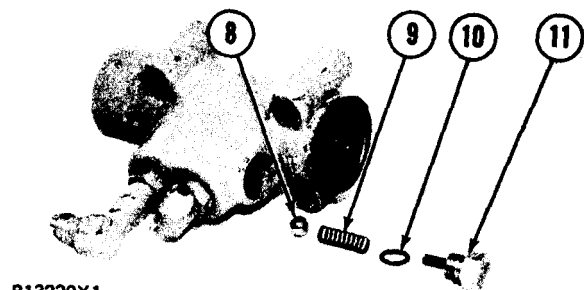

B13220X1

STEERING NEUTRALIZER VALVES

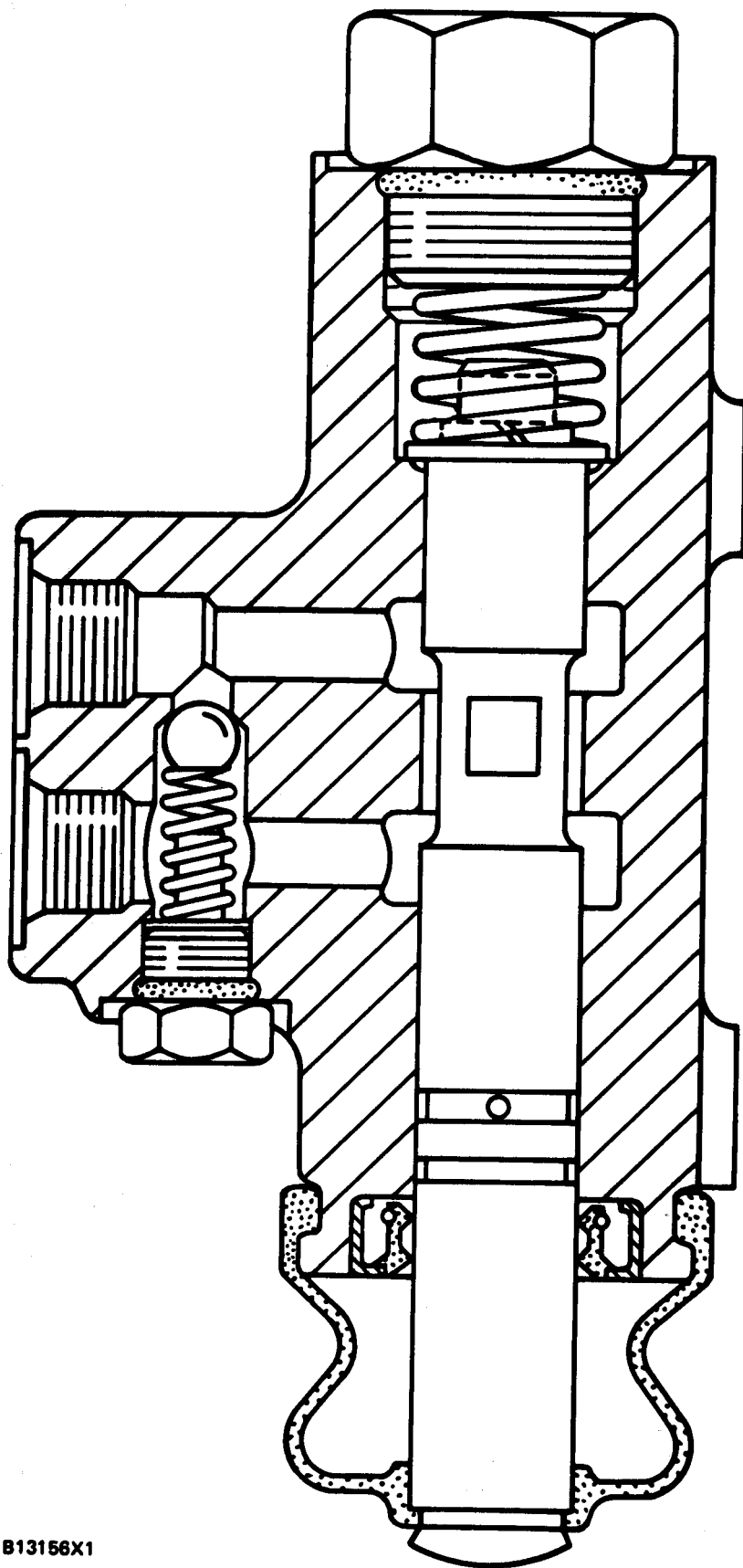

B13156X1

STEERING NEUTRALIZER VALVES

ASSEMBLE STEERING NEUTRALIZER VALVES 4330-16

Tools Needed		A
1P510	Driver Group	1

1. Install the lip type seal with tooling (A) as shown.

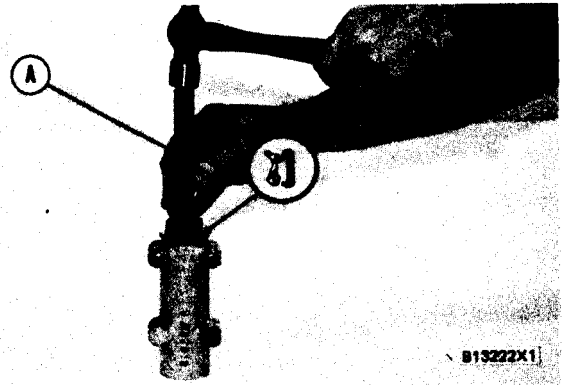

2. Put ball (1) and spring (2) in position. Install O-ring seal (4) and plug (3) into the valve body.

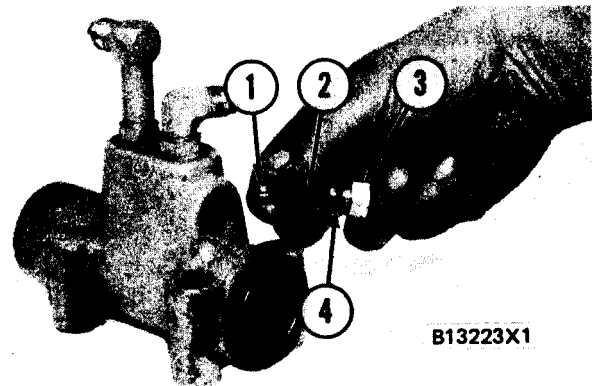

3. Install washer (6), lockwasher and bolt (5) on valve spool (7).

4. Put a small amount of oil on the valve spool and the lips of the lip type seal.

5. Put valve spool (7) and spring (10) in position in the valve body. Install O-ring seal (9) and plug (8).

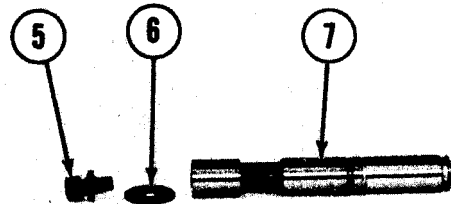

6. Install boot (11) on the valve body.
a) install steering neutralizer valves

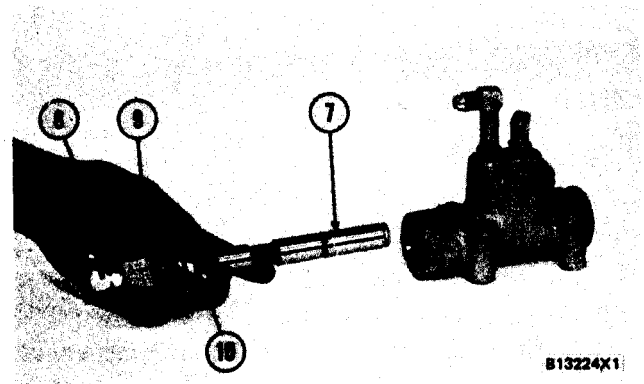
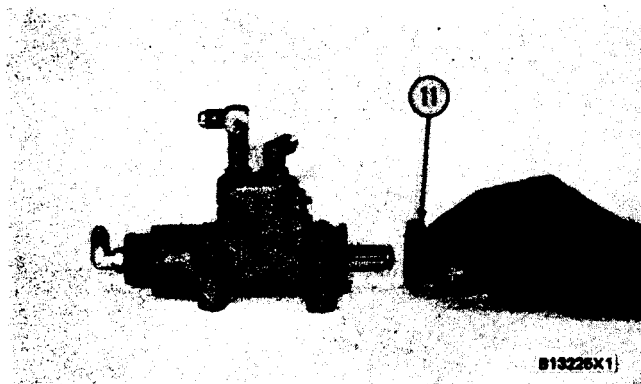

STEERING CONTROL VALVE MANIFOLD

Models 950BNS and 950BS

REMOVE STEERING CONTROL VALVE MANIFOLD

4307-11

1. Drain the oil from the hydraulic tank below the level of the steering control valve manifold.

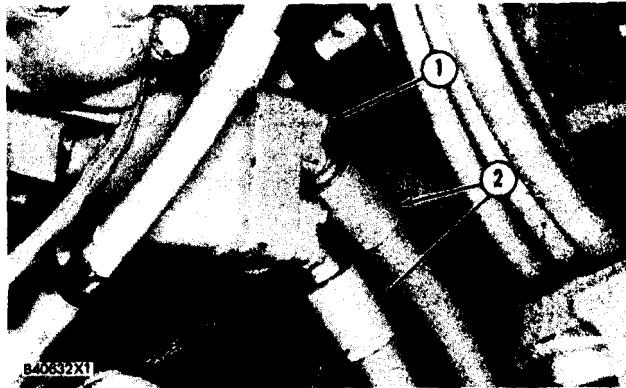

2. Remove bolts (1) and disconnect hoses (2) from the steering control valve manifold.

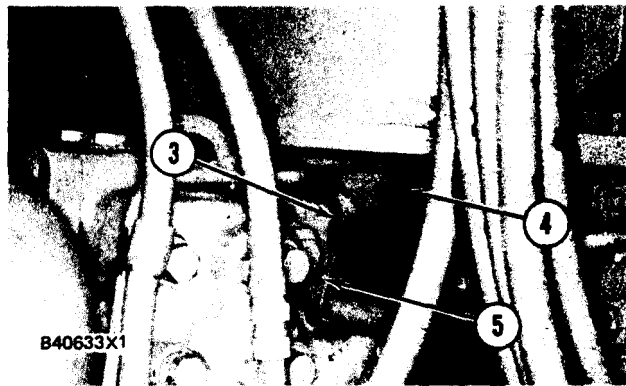

3. Remove bolts (3) and disconnect clip (5) and hose (4) from the steering control valve manifold.

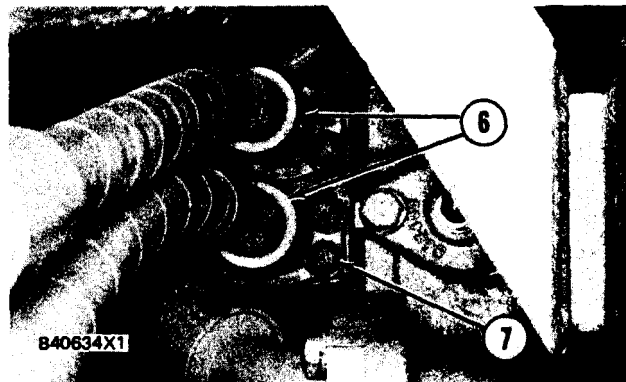

4. Remove bolts (7) and disconnect hoses (6) from the steering control valve manifold.

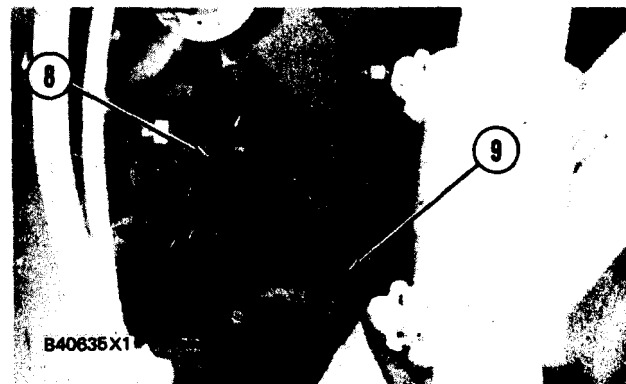

5. Remove bolts (8) and remove steering control valve manifold (9) from the steering control valve.

STEERING CONTROL VALVE MANIFOLD

INSTALL STEERING CONTROL VALVE MANIFOLD

4307-12

1. Clean and inspect the O-ring seals and make a replacement if any seals are worn or damaged.
2. Install O-ring seals (1) on steering control valve manifold (2).
3. Put steering control valve manifold (2) in position on the steering control valve and install bolts (3) that hold the manifold.
4. Install the O-ring seals on hoses (4) and connect hoses (4) on the steering control valve manifold.
5. Install the O-ring seal on hose (5) and connect hose (5) and clip (6) on the steering control valve manifold.
6. Install O-ring seals (7) on hoses (8) and connect hoses (8) on the steering control valve manifold.
7. Fill the hydraulic tank with oil to the correct level.

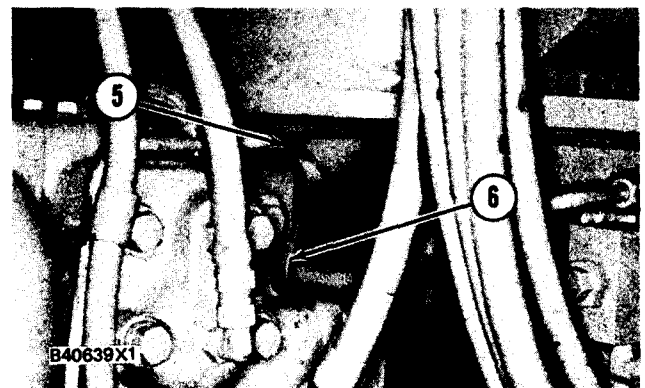
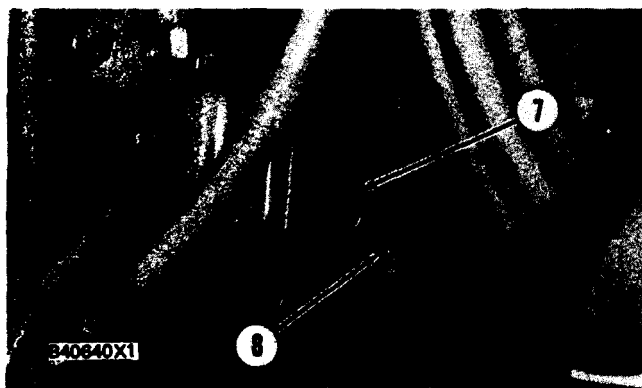
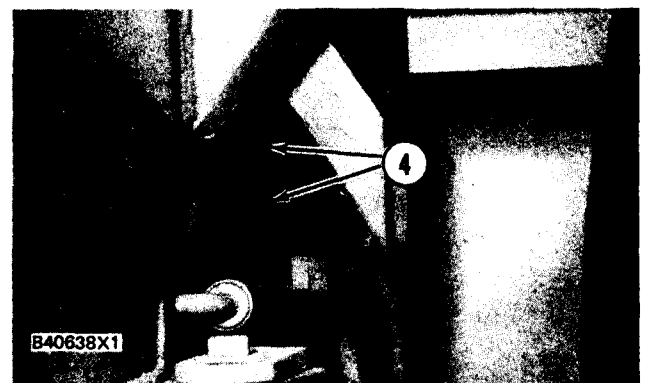
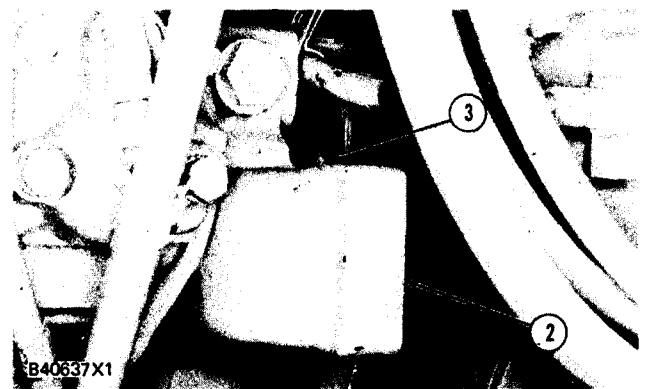
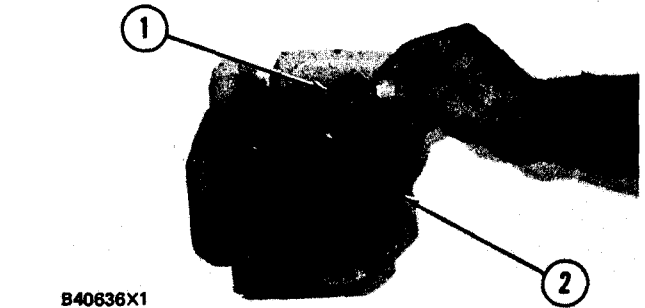

STEERING CONTROL VALVE MANIFOLD Models 950BNSCE and 950BSCE

REMOVE AND INSTALL STEERING CONTROL VALVE MANIFOLD 4307-010

Start By:

a. connection of steering frame link lock

1. Drain the oil approximately half way down in the hydraulic tank.

2. Remove the bolts that hold tube (1), and remove the tube from the rear, of the steering control valve manifold.

3. Remove the bolts that hold hose (2), and remove the hose from the rear of the steering control valve manifold.

4. Disconnect line (7) and hose (4).

5. Remove two hoses (3) and make-up valve (8).

6. Remove bolts (5), and remove steering control valve manifold (6).

7. Clean and inspect the O-ring seals and make a replacement if any seals are worn or damaged.

8. Make sure the O-ring seals are in position on the steering control valve manifold.

9. Put steering control valve manifold (6) in position, and install bolts (5) that hold it.

10. Install make-up valve (8) and two hoses (3).

11. Connect line (7) and hose (4).

12. Position hose (2), and install the bolts that hold it. Position tube (1), and install the bolts that hold it.

13. Fill the hydraulic tank with oil to the correct level. See the Maintenance Guide.

End By:

a. separation of the steering frame lock link

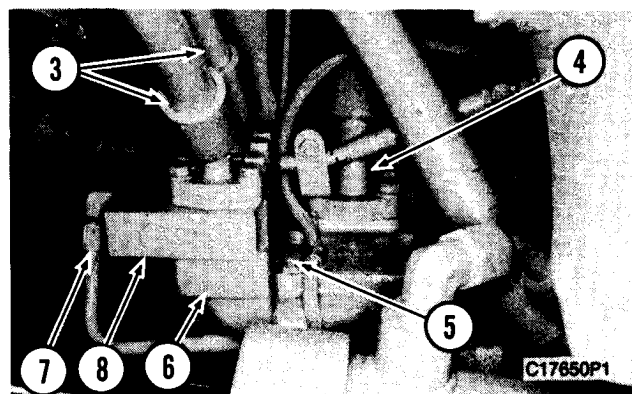
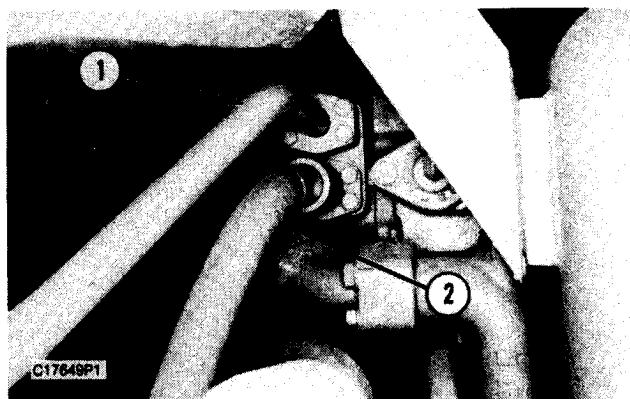

STEERING CONTROL VALVE

Models 950BNS and 950BS

REMOVE STEERING CONTROL VALVE

4102-11

start by:

a) connection of anti-pivot link

WARNING

To prevent personal injury release the pressure from the hydraulic system before any lines are removed or disconnected.

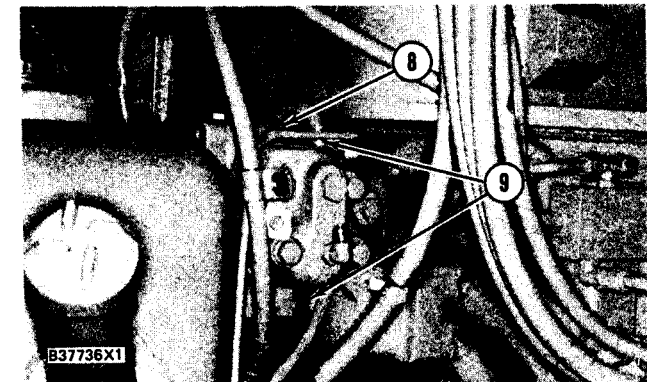
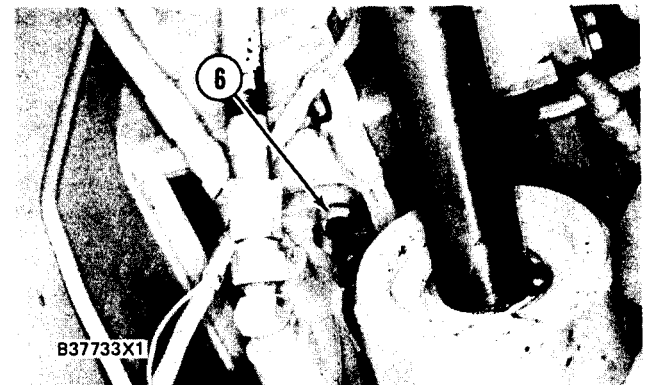
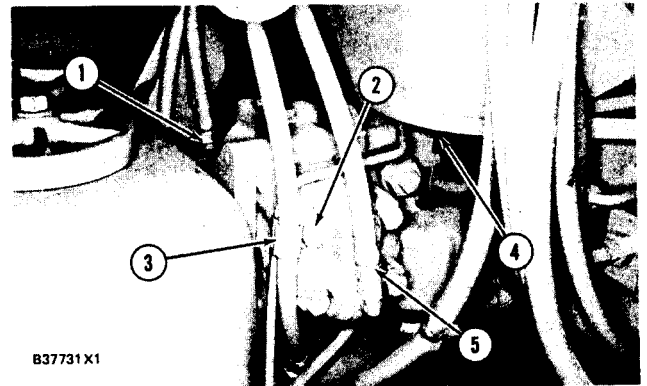

1. Drain the oil level in the hydraulic tank half way down.
2. Remove bolt (2) and disconnect clips (3) from the steering control valve.
3. Disconnect oil lines (1) and (5) from the steering control valve.
4. Loosen top two bolts (4) that hold the hose assembly to the steering manifold and steering manifold to the steering control valve.
5. Remove bolts (6) that connect the manifold to the steering control valve.
6. Remove bolts (7) that hold the steering control manifold to steering control valve.
7. Remove three bolts (9) and remove steering control valve (8) from the hydraulic tank.

STEERING CONTROL VALVE Models 950BNS and 950BS

REMOVE STEERING CONTROL VALVE

4102-11

start by:

- a) connection of anti-pivot link

WARNING

To prevent personal injury release the pressure from the hydraulic system before any lines are removed or disconnected.

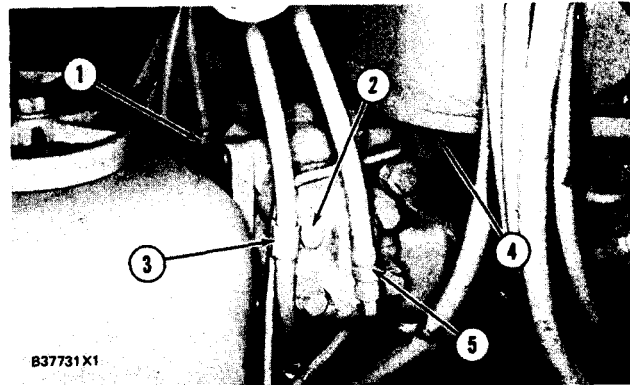

1. Drain the oil level in the hydraulic tank half way down.

2. Remove bolt (2) and disconnect clips (3) from the steering control valve.

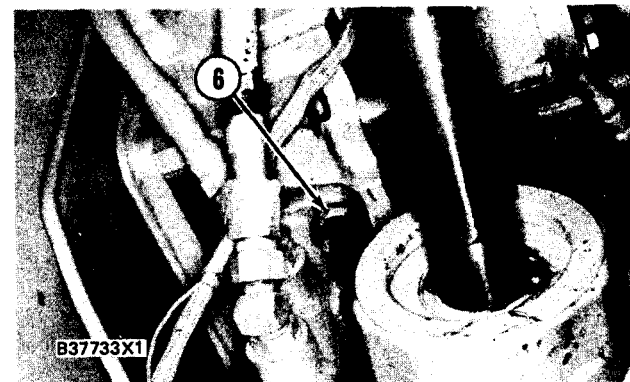

3. Disconnect oil lines (1) and (5) from the steering control valve.

4. Loosen top two bolts (4) that hold the hose assembly to the steering manifold and steering manifold to the steering control valve.

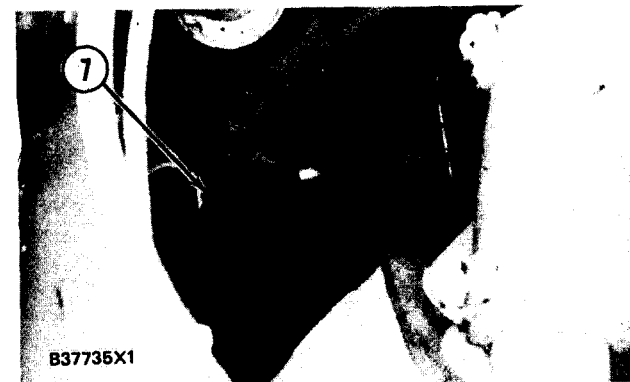

5. Remove bolts (6) that connect the manifold to the steering control valve.

6. Remove bolts (7) that hold the steering control manifold to steering control valve.

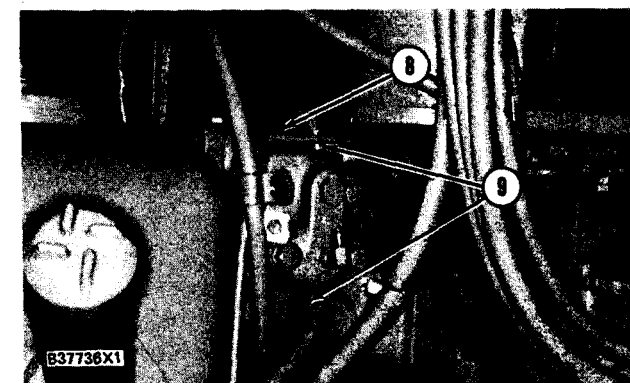

7. Remove three bolts (9) and remove steering control valve (8) from the hydraulic tank.

STEERING CONTROL VALVE

Models 950BNS and 950BS

INSTALL STEERING CONTROL VALVE 4102-12

1. Check and make a replacement, if necessary, of all O-ring seals before the steering control valve is installed.
2. Put steering control valve (1) in position on the machine.
3. Install three bolts (2) that hold the steering control valve to the hydraulic tank.
4. Tighten bolts (3) that hold the hose assembly to the manifold and the manifold to the steering control valve.
5. Install bolts (4) that hold the manifold to the steering control valve.
6. Install bolts (5) that hold the manifold to the steering control valve.
7. Connect the clips and install bolt (7) on the steering control valve.
8. Connect hose assemblies (6) and (8) to the steering control valve.
9. Fill the hydraulic tank.
end by:
a) separation of anti-pivot link

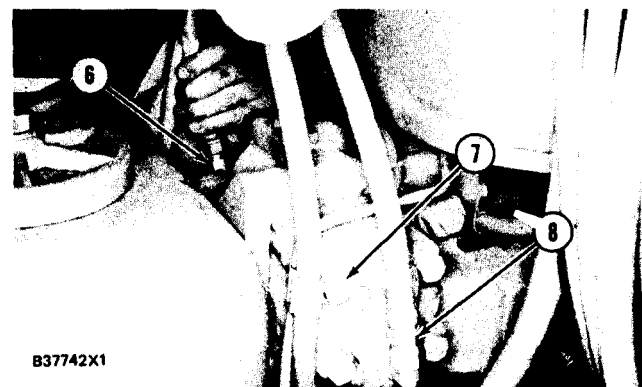
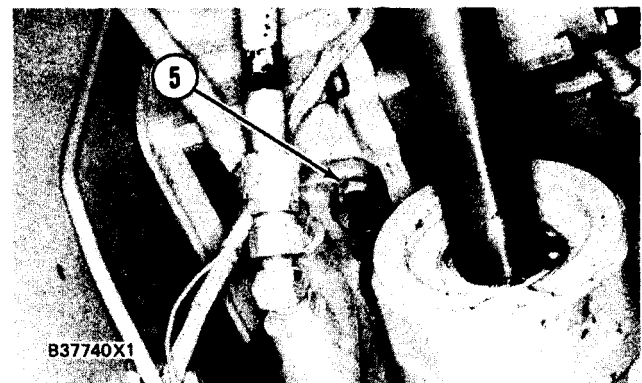
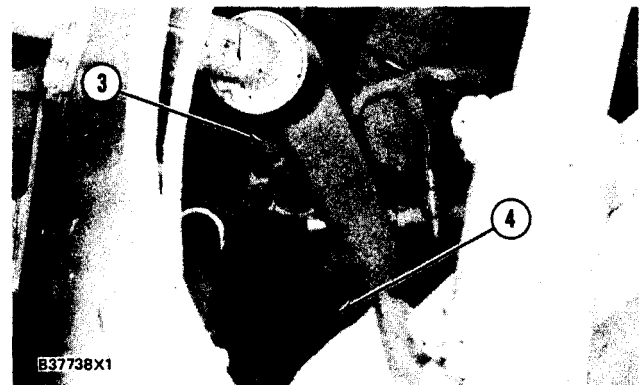
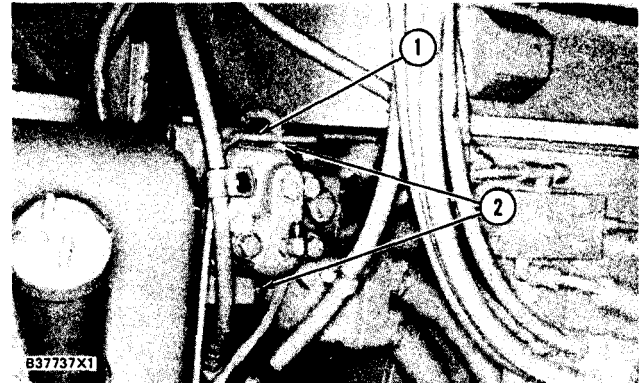

VEHICLE SYSTEMS

STEERING CONTROL VALVE

Models 950BNSCE and 950BSCE

REMOVE AND INSTALL STEERING CONTROL VALVE 4102-010

Start By:

- a. connection of steering frame link lock

To prevent personal injury release the pressure from the hydraulic system before any lines are removed or disconnected.

REMOVE STEERING CONTROL VALVE

1. Drain the oil half way down in the hydraulic tank.
2. Remove bolts (1) that hold hose (2) to the steering control valve manifold. Remove hose (2) and bolts (3) that hold the steering control valve manifold to the steering control valve.
3. Remove front oil line (4) and rear oil line (not shown). Remove bolts (7) that hold steering control valve manifold (5) to steering control valve (10).
4. Remove oil line (8) from elbow (11). Remove bolts (9), and move elbow (11) away from steering control valve (10).
5. Remove bolts (6), and remove steering control valve (10).

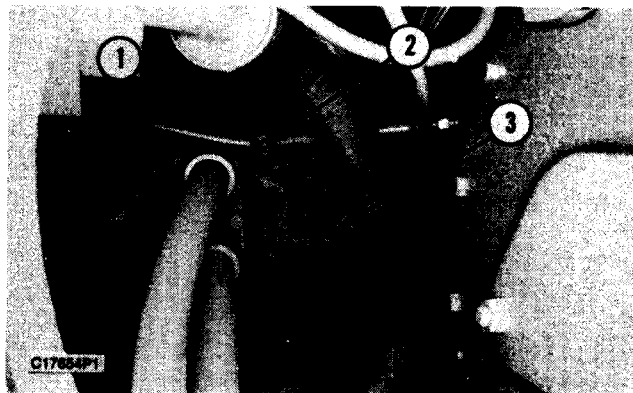

INSTALL STEERING CONTROL VALVE

1. Check the condition of all O-ring seals before the steering control valve is installed. If any are worn or damaged, make a replacement with new parts.
2. Position steering control valve, and install bolts (6) that hold it in place.
3. Position elbow (11), and install bolts (9) that hold it. install oil line (8) on elbow (11).
4. Install bolts (7) that hold steering control valve manifold (5) to steering control valve (10). Install front oil line (4) and rear oil line (not shown).
5. Install bolts (3) that hold steering control valve (10). Position hose (2), and install bolts (1).
6. Fill the hydraulic tank. See the Maintenance Guide.

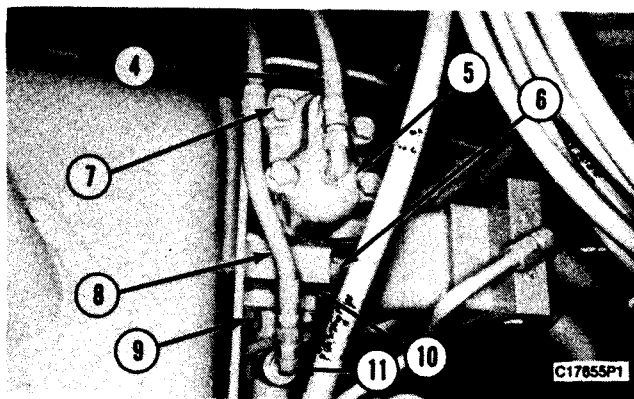

End By:

- a. separation of steering frame lock line

STEERING CONTROL VALVE

Models 950BNSCE and 950BSCE

Disassemble Steering Control Valve 4102-015

Start By:

a. remove steering control valve

1. Remove plug (4), shims (3), spring (2) and valve (1) from the cover.

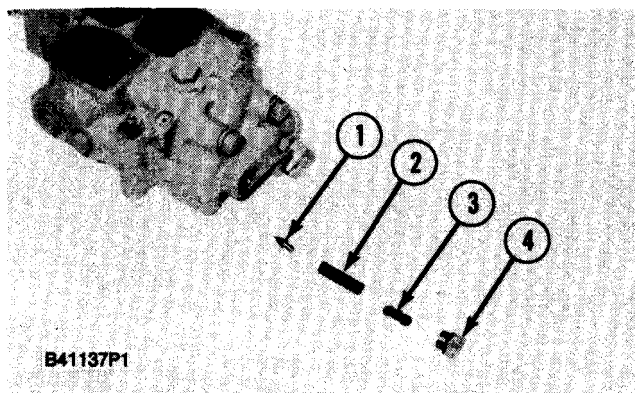

2. Remove bolts (5) and cover (6) from the valve group.

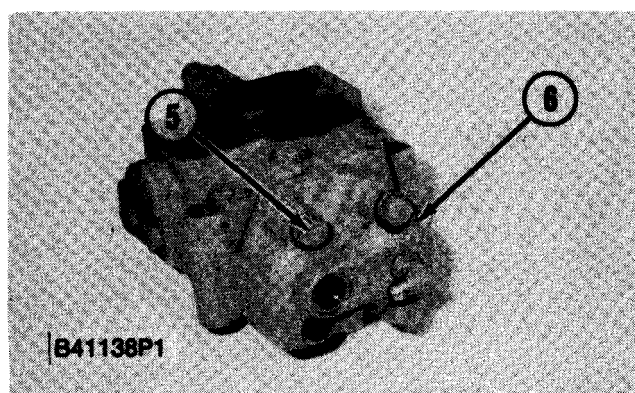

3. Remove seat (8) and O-ring seals (7) from cover (6).

4. Remove O-ring seal (9) from seat (8).

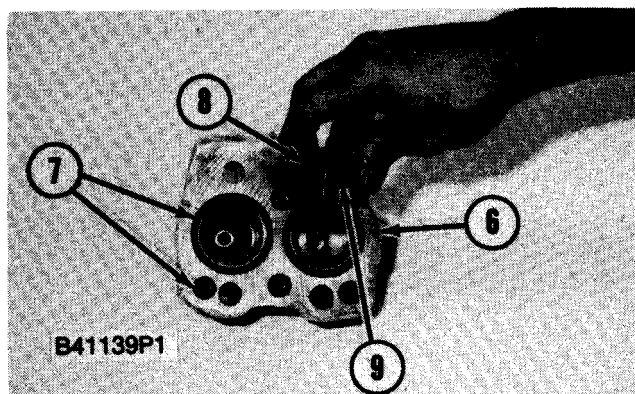

5. Remove directional valve spool assembly (10) and valve group (11) from the valve body.

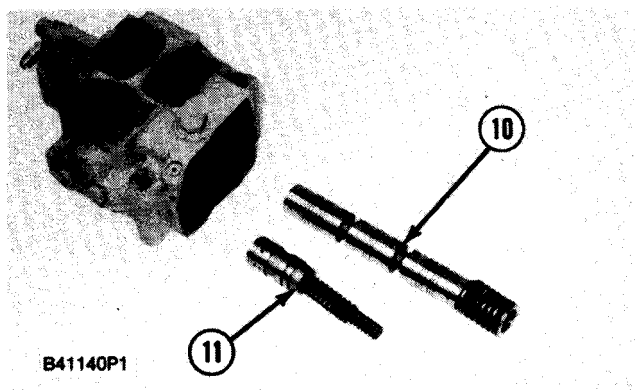

STEERING CONTROL MAKE-UP VALVE Models 950 BNSCE and 950BSCE

DISASSEMBLE AND ASSEMBLE STEERING CONTROL MAKE-UP VALVE

1. Remove plugs (1) and O-rings (2).
2. Remove springs (3) and balls (4).
3. Inspect seats (5) in valve body (1). Replace parts as necessary.
4. Install balls, springs, O-rings and plugs,

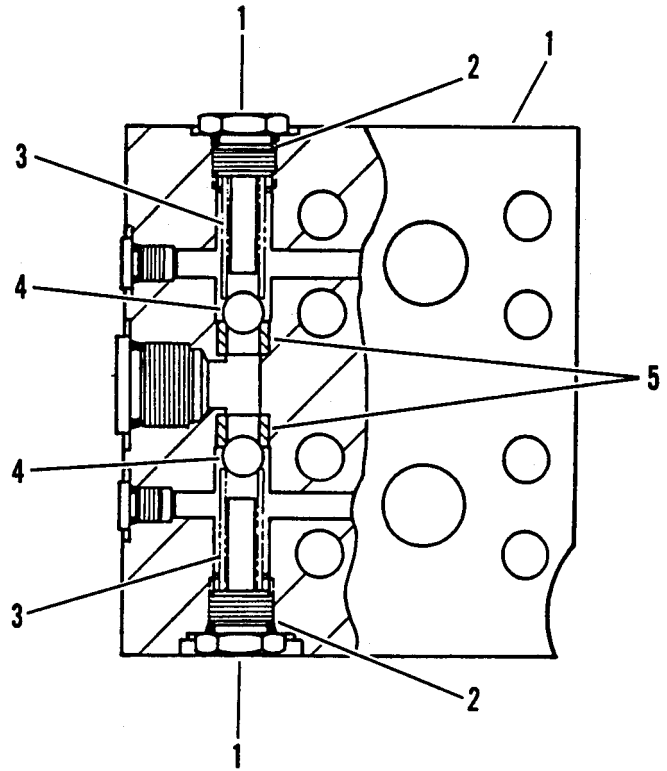

STEERING CONTROL VALVE

WARNING

Bolt (19) holds spring (14) under compression. To prevent personal injury carefully remove bolt (19).

6. Remove bolt (19), washers (15), retainer (18), spring (14), spacer (17), retainer (13) and shims (16) from valve spool (12).

7. Remove springs (21) and (23) and shims (22) from valve spool (20).

8. Remove plug (26), seat (25), ball (27) and seat (24). Remove the O-ring seals from the seats and plug.

9. Remove stop assembly (28) from the valve body.

10. On models 950BNS and 950BS, remove plug assembly (29), spring (30) and bolt (31) from the valve body.

11. Remove bolts (32) and cover (33) from the valve body.

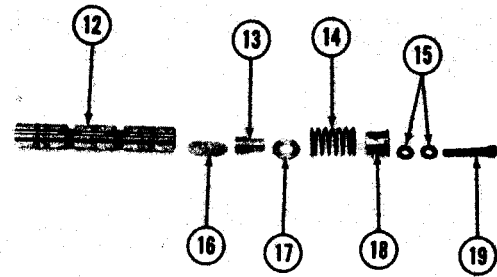

B41142X1

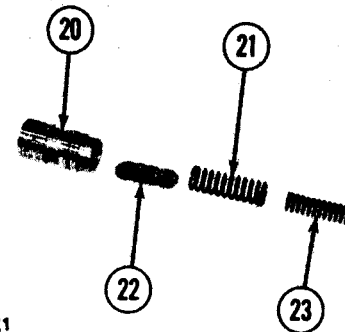

B41141X1

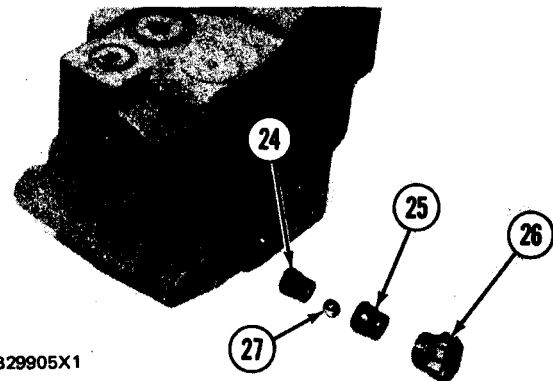

B29905X1

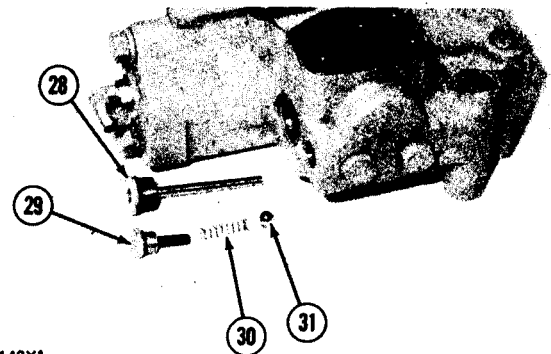

B41143X1

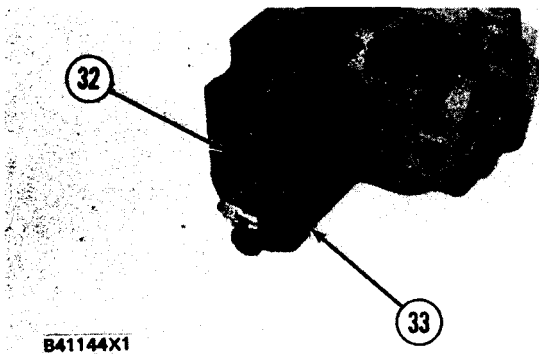

B41144X1

STEERING CONTROL VALVE

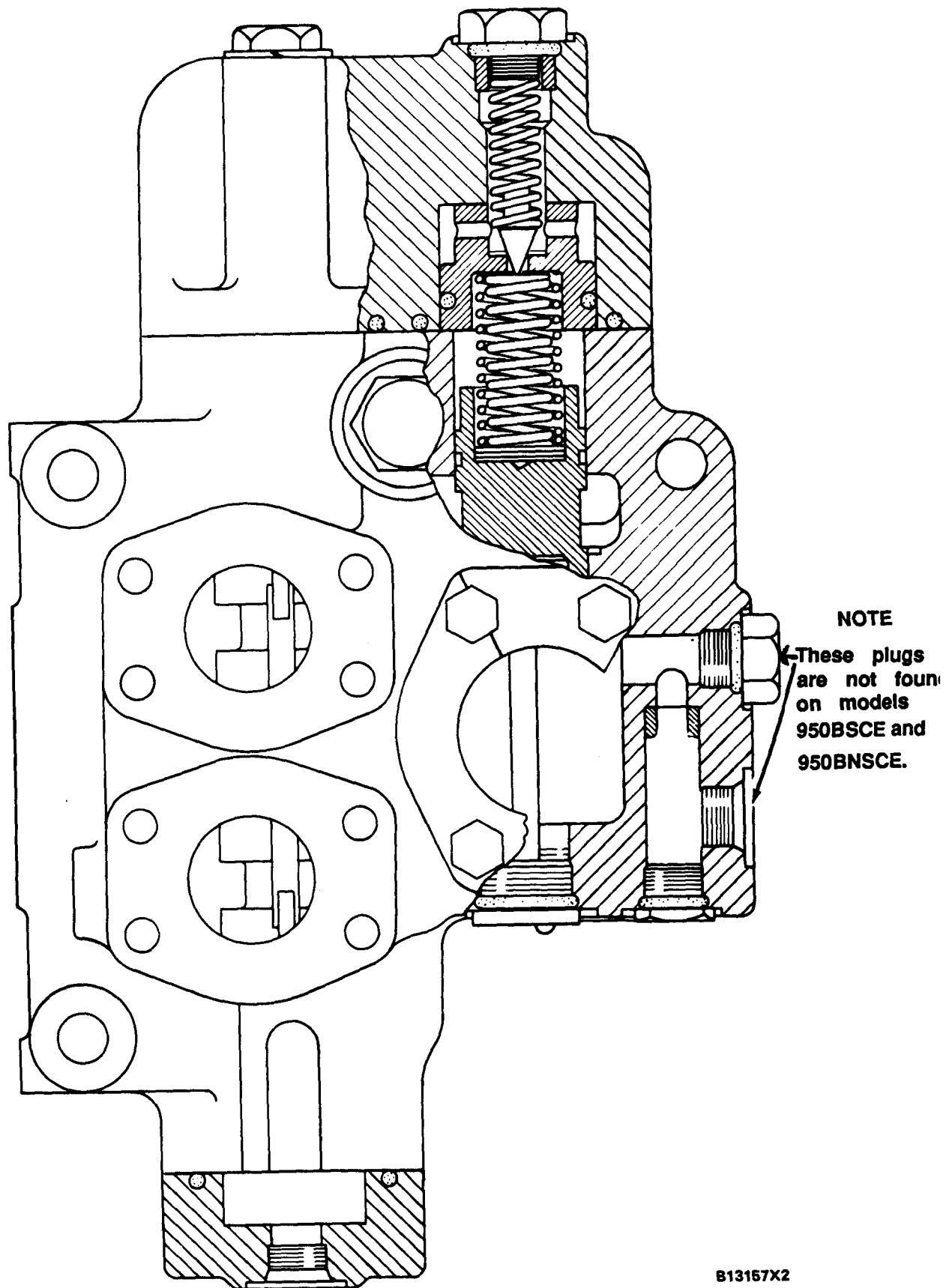

STEERING CONTROL VALVE

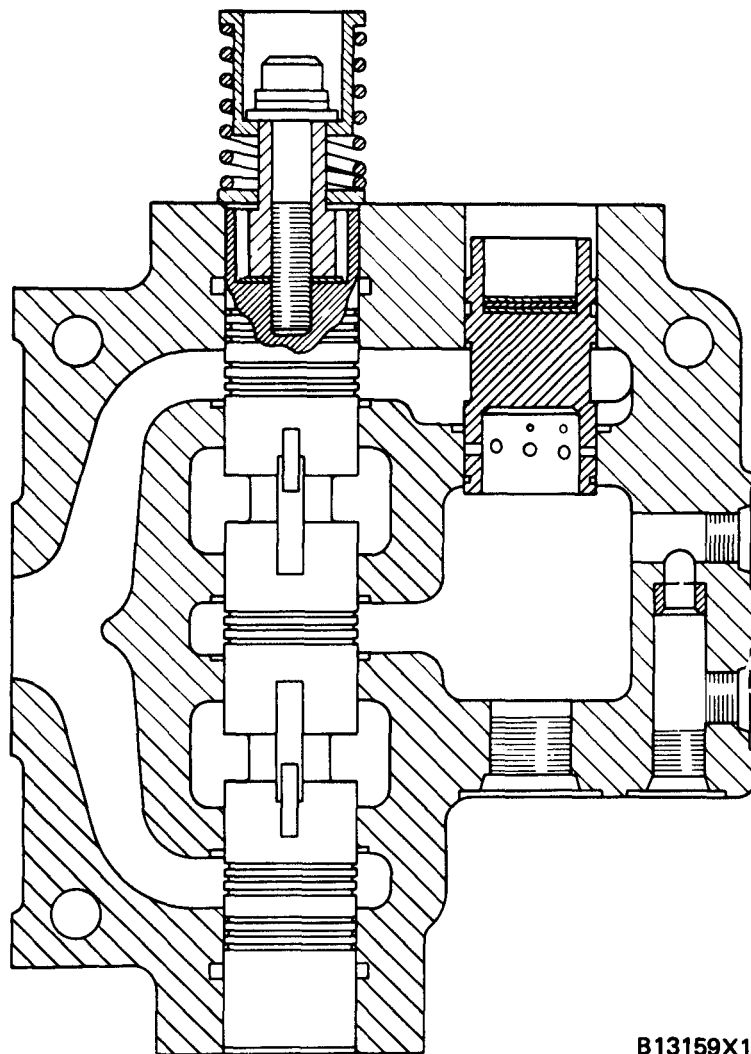
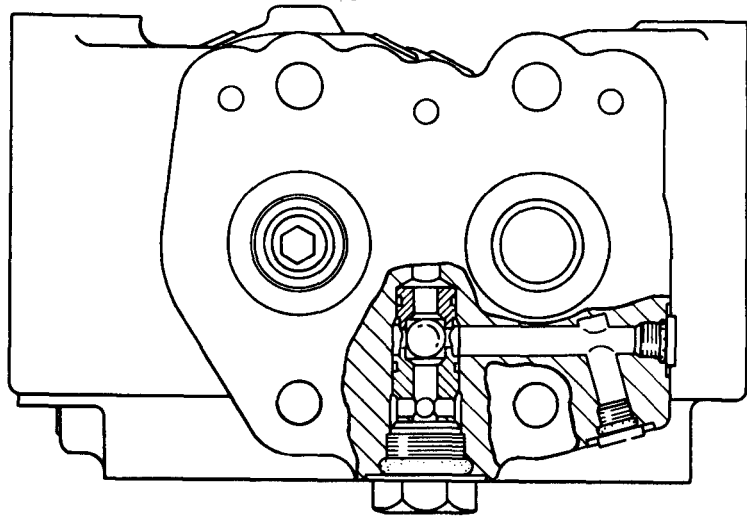

NOTE
These plugs are
not found on
models 950BSCE
and 950BNSCE.

B13159X1

STEERING CONTROL

ASSEMBLE STEERING CONTROL VALVE

4102-16

1. Clean and inspect all parts. Make a replacement of all parts that are worn or damaged. Put a small amount of clean oil on all machine surfaces and O-ring seals.

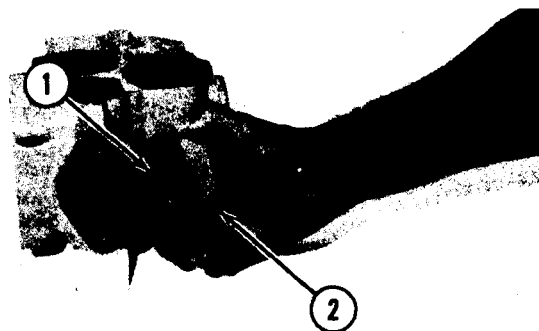

B41145X1

2. Install O-ring seal (1) on cover (2).

3. Install cover (2) on the valve body.

4. Put the O-ring seals in position on the seats and plug.

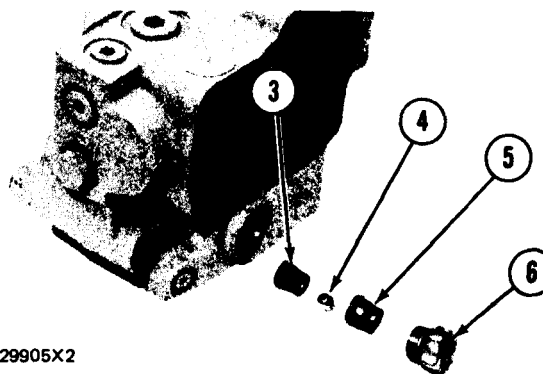

B29905X2

5. Install seat (3), ball (4) and seat (5) in the valve body.

6. Install plug (6) in the valve body.

7. Install O-ring seal (8) on stop assembly (7).

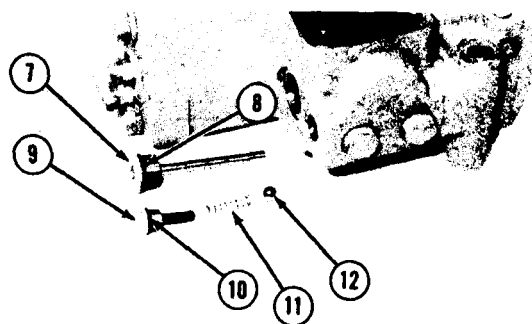

B41146X1

8. Install stop assembly (7) in the valve body.

NOTE: Steps 9 and 10 apply to models 950BNS and 950BS only.

9. Install O-ring seal (10) on plug assembly (9).

10. Install ball (12), spring (11) and plug assembly (9) in the valve body.

11. Install shims (13), retainer (18), spacer (14), spring (19), retainer (15), washers (20) and bolt (16) in valve spool (17).

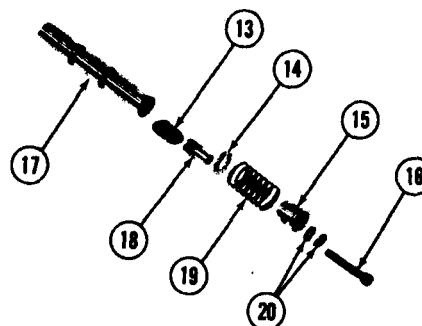

B41147X1

STEERING CONTROL VALVE

12. Install shims (23), spring (22) and spring (24) in valve spool (21).

13. Install valve spool assemblies (25) and (26) in the valve body.

14. Install O-ring seals (28) on cover (30).

15. Install O-ring seal (27) on seat (29).

16. Install seat (29) in cover (30).

17. Install cover (30) on the valve body.

18. Install valve (33) and spring (31) in the valve body.

19. Install the O-ring seal on plug (32).

20. Install shims (34) in plug (32) and install the plug in the valve body.

end by:
a) install steering control valve

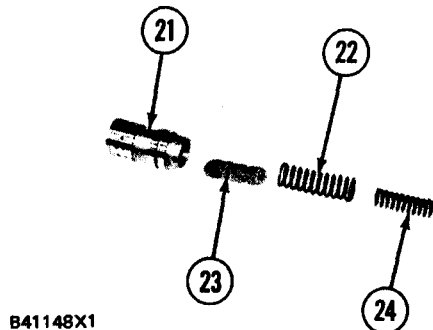

B41148X1

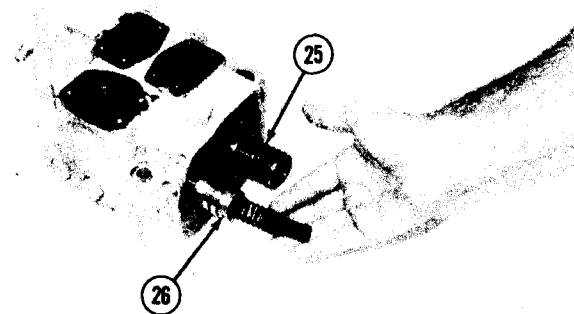

B41149X1

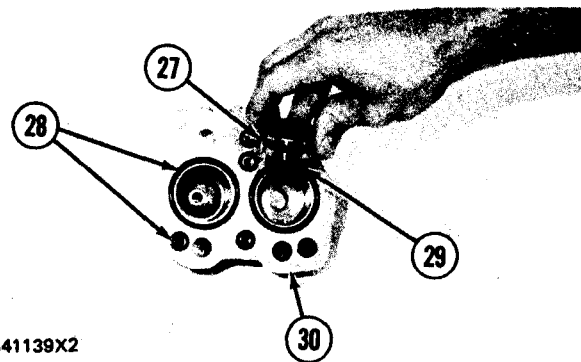

B41139X2

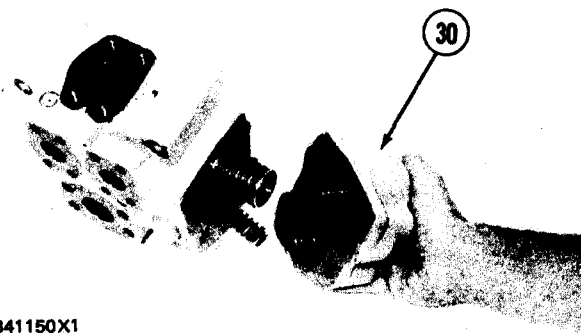

B41150X1

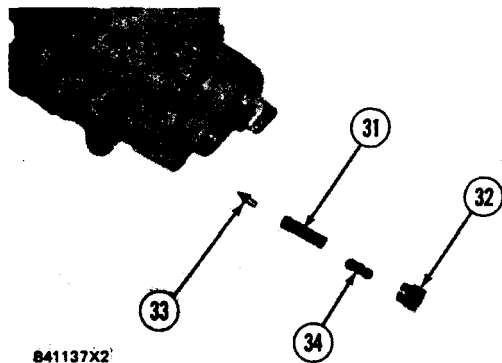

B41137X2

Supplemental Steering Pump

Remove Supplemental Steering Pump

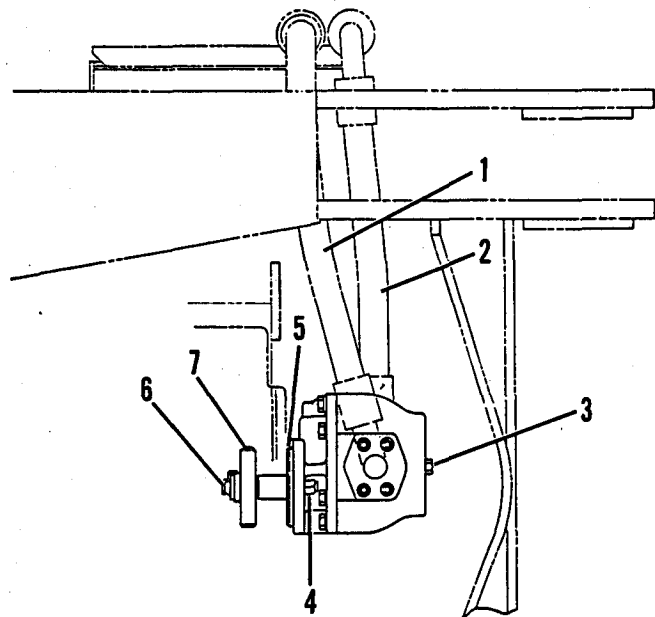

1. Disconnect oil lines (1 and 2) from steering pump (3).
2. Fasten a suitable lifting device (not shown) to the steering pump. Remove two nuts and washers (4), and remove supplemental steering pump (3). The weight is approximately 65 lb. (29 kg).
3. Remove O-ring seal (5).
4. Remove bolt, lock, and washer (6).
5. Remove gear (7).

Install Supplemental Steering Pump

1. Install gear (7), and bolt, lock, and washer (6).
2. Tighten bolt securely, then bend tab of lock to retain bolt.
3. Attach a suitable lifting device (not shown) to the supplemental steering pump (3) and lift pump into position.
4. Install two nuts and washers (4) and tighten securely.
5. Connect oil lines (1 and 2) to pump (3).

Disassemble Supplemental Steering Pump

START BY:

- a) remove supplemental steering pump

1. Clean the outside of the pump before it is disassembled.

NOTE: Put identification on all parts for correct position at assembly.

2. Remove eight bolts (1) and washers (2), and flange (3) from the pump housing.
3. Remove O-ring seal (4) from flange (3).
4. Remove O-ring seals (5) and backup rings (6) from support rings in the flange.
5. Remove two lip type seals (7A and 7B) and the spacer ring (8) from the flange.
6. Remove isolation plates (9) and retainer assembly (10) from the pump housing (23).
7. Remove pressure plate (11) from the pump housing (23).
8. Remove drive gear (12) and idler gear (13) from the pump housing (23).
9. Remove bushings (14) from both gears (12 and 13).
10. Remove pressure plate (15) from the pump housing (23).
11. Remove isolation plates (16) and retainer assembly (17) from the pump housing (23), with a seal pick.
12. Remove O-ring seals (18) and the backup rings (19) from the pump housing (23).
13. Turn the pump housing (23) over and remove plug (20) to clean the pump housing.
14. Remove O-ring (21) from plug (20).
15. Inspect dowel pins (22) for damage. Remove and replace if necessary.

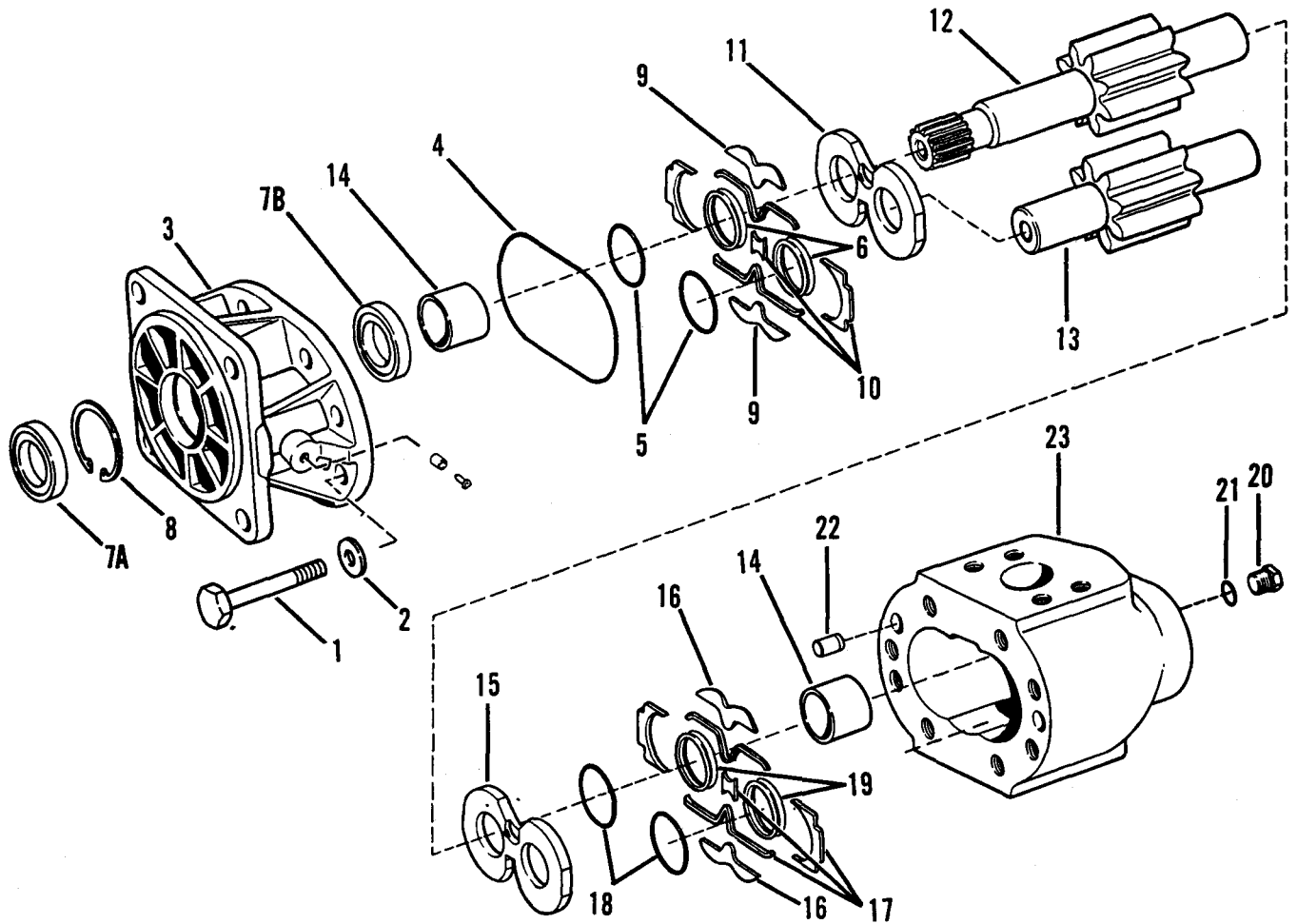

Assemble Supplemental Steering Pump

FOR IDENTIFICATION PURPOSES ONLY

Tools Needed	A
1P510 Drive Group	1

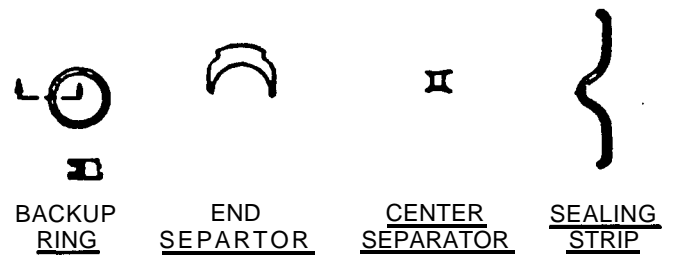

Mandatory Replacement Parts Seal Kit 1U2772

Qty	Description
2	Seal (7/16 x 1-1/4" x 2")
1	Snap Ring (1/16" thick x 2-7/32" O.D.)
1	O-ring (3/32" x 4-1/4" x 4-7/16")
4	O-ring (1/16" x 1-3/8" x 1-1/2")
1	O-ring (5/64" x 15/32" x 5/8")
4	Sealing Strip
2	Center Separator
4	End Separator
4	Backup Ring
1	Plug (13/64" x 7/16" Lg.)

1. Make sure all of the parts of the hydraulic pump are clean and free of dirt and foreign material before the pump is assembled.

NOTE: See DIAGNOSING TYRONE GEAR PUMP FAILURES, Form No. FEG45137, for assistance in inspection of the parts.

2. Inspect all parts of the pump. Check the bores in the pump body. Measure the depth of grooves in each bore. If the grooves are deeper than .015 in. (0.38 mm), a replacement of the pump body and gears must be made.

3. Install O-ring (21) on plugs (20). Install plug (20).

4. Refer to exploded view illustration for retainer assembly (17), isolation plates (16), backup rings (19) and O-ring seals (18) installation.

NOTICE

There are two isolation plates needed in the bottom of the pump housing and two in the top. The isolation plates hold the seal components in place. The isolation plates with the round edges on the outer radius on one edge go in the bottom of the pump housing with the round edge down. The isolation plates with the straight (square) edges on the radius go next to the top flange.

5. Install backup rings (19) and O-ring seals (18). Install retainer assembly (17). Install isolation plates (16) with the rounded edges down.

6. Install pressure plates (15) in its original position with the bronze surface of the pressure plate toward the gears in the pump.

7. Install bushings (14) onto gears (12 and 13).

8. Install idler gear (13) and drive gear (12) into the pump housing.

9. Install pressure plate (11) in its original position with the bronze surface of the pressure plate toward the gears in the pump.

10. Install seal (7B) in the flange with tooling (A). Install the seal with the lip of the seal toward the inside of the pump.

11. Install spacer ring (8).

12. Install seal (7A) in the flange with tooling (A). Install the seal with the spring loaded lip toward the inside of the pump.

13. Put a thin layer of 1P808 General Purpose Lubricant on the seals, retainer assemblies and isolation plates to hold them in place.

14. Install backup rings (6) and O-ring seals (5) on flange (3). Install retainer assembly (10). Install isolation plates (9) with the straight (square) edge toward the flange.

15. Install O-ring seal (4) on the flange.

16. Install flange (3) on the pump housing (23).

17. Install eight bolts and washers (2) that hold the flange to the pump housing. Tighten the bolts to a torque of 85 ± 5 lb. ft. (115 ± 7 N.m).

END BY:

a) install supplemental steering pump

PILOT AND HYDRAULIC PUMP

REMOVE PILOT AND HYDRAULIC PUMP

5073-11

- start by:
a) remove seat*

*This operation is in the 950B OPERATOR'S STATION, DISASSEMBLY AND ASSEMBLY section.

WARNING

To prevent personal injury release the pressure from the hydraulic system before any lines are removed or disconnected.

1. Drain the hydraulic tank below the level of the hydraulic pump.
2. Remove the floor panel from under the seat.
3. Remove bolts (2) and disconnect tube assembly (1) from the bottom of the hydraulic pump.
4. Disconnect oil lines (3), (4) and (5) from the pilot and hydraulic pump.
5. Remove bolts (6) and disconnect hose assembly (7) from the hydraulic pump.
6. Remove bolts (9) and disconnect hose assembly (8) from the hydraulic pump.
7. Fasten a hoist, or use two persons, to hold pilot and hydraulic pump.
8. Remove bolts (10) and remove pilot and hydraulic pump (11). The weight of the pump is 60 lb. (27 kg).

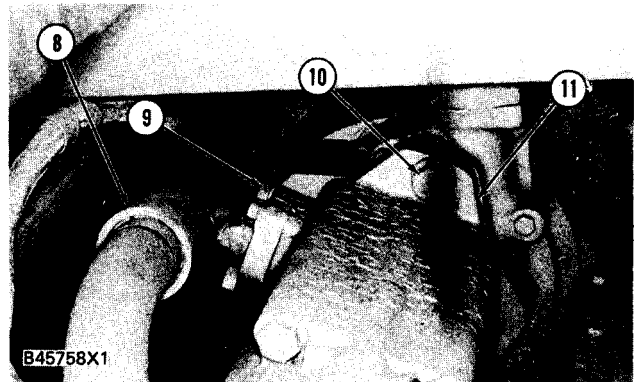
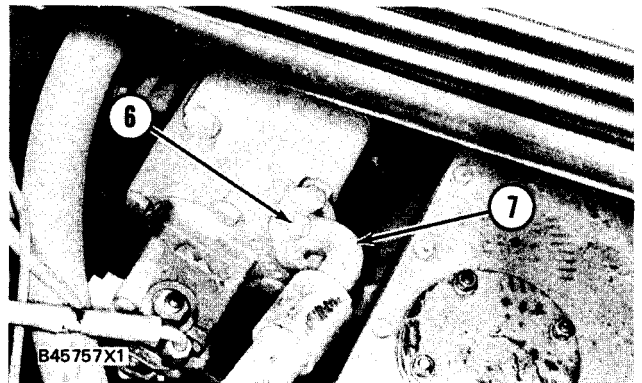
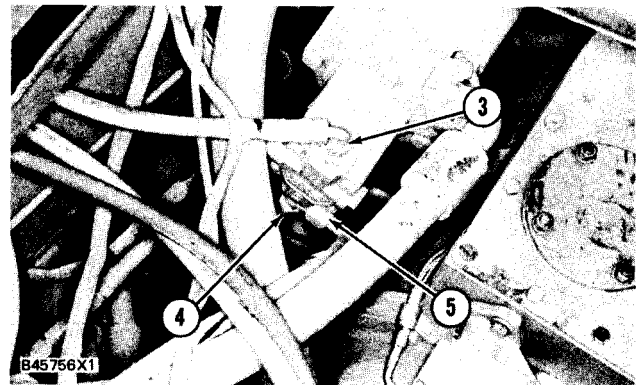
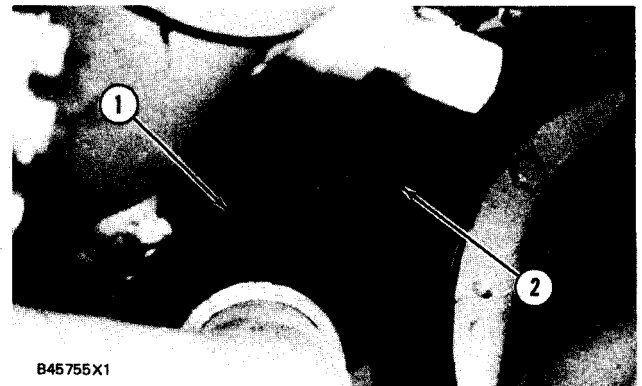

PILOT AND HYDRAULIC PUMP

INSTALL PILOT AND HYDRAULIC PUMP

5073-12

1. Put O-ring seal (1) in position as shown.
2. Use a hoist or two persons to put pilot and hydraulic pump (4) into position on the transmission pump. Make sure the splines on the shaft are in alignment with the splines in the transmission pump.
3. Install bolts (3) that hold the pump in position.
4. Make sure the O-ring seal is in position and connect hose assembly (2) to the pump.
5. Make sure the O-ring seal is in position and connect hose assembly (5) on the pump.
6. Connect hose assemblies (6), (7) and (8) to the pilot pump.
7. Make sure the O-ring seal is in position. Connect tube assembly (9) to the bottom of the pump.
8. Install the floor panel under the seat.
9. Fill the hydraulic tank to the correct level.
end by:
a) install seat*

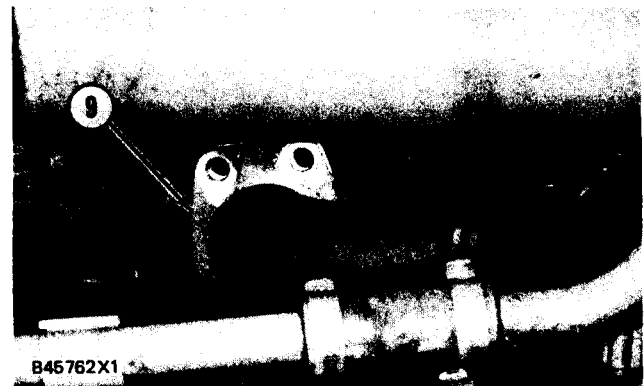
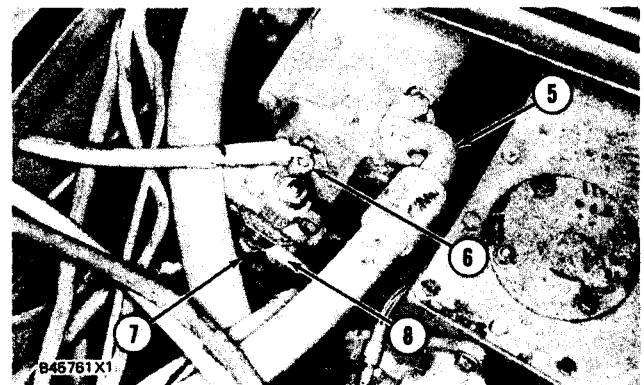
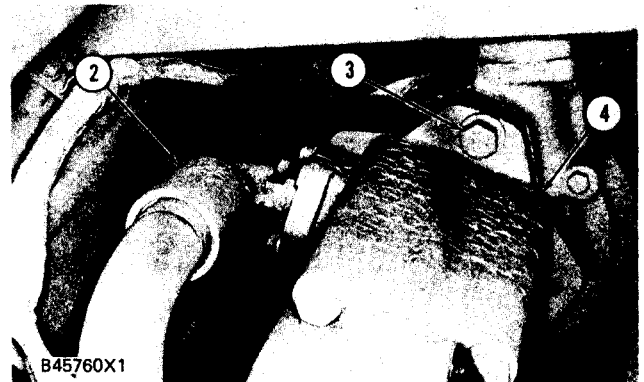
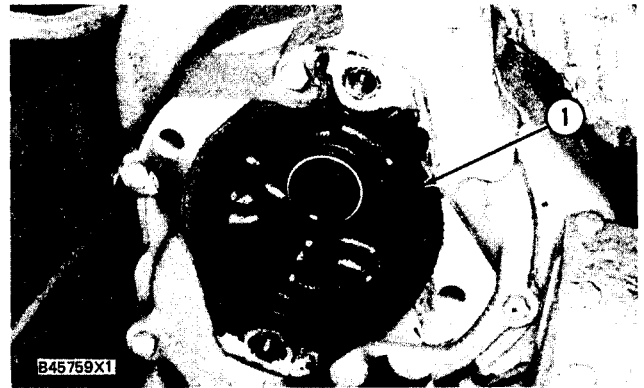

*This operation is in the 950B OPERATOR'S STATION DISASSEMBLY AND ASSEMBLY.

PILOT AND HYDRAULIC PUMP

DISASSEMBLE PILOT AND HYDRAULIC PUMP

5073-15

Tools Needed		A
1P1859	Snap Ring Pliers	1

start by:

a) remove pilot and hydraulic pump

1. For the correct assembly of the parts the pump rotation is in a clockwise direction when seen at the pilot end of the hydraulic pump.

2. Remove O-ring seal (1) from the pump body.

3. Remove the bolts, cover (4) and ring assembly (2) from the pump.

4. Remove spring (3) from ring assembly (2).

WARNING

Spring (6) is under compression behind plug (8). To prevent personal injury carefully remove plug (8).

5. Remove plug (8), spring (6) and spool assembly with screen" (5) from cover (4).

6. Remove O-ring seal (7) from plug (8).

WARNING

Spring (10) is under compression behind bolt (13). To prevent personal injury carefully remove bolt (13).

7. Remove bolt (13), shims (12), valve (11) and spring, 10) from valve spool (9).

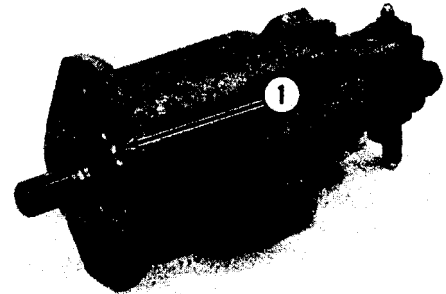

B44103X1

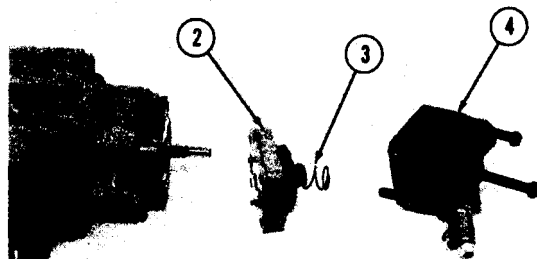

B44104X1

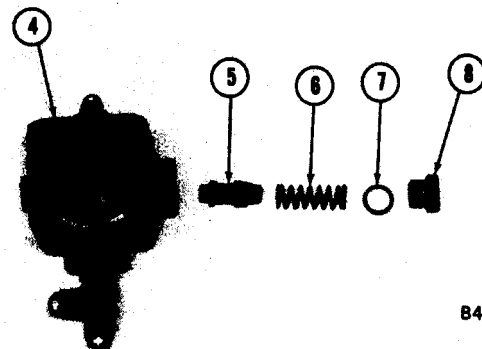

B44105X1

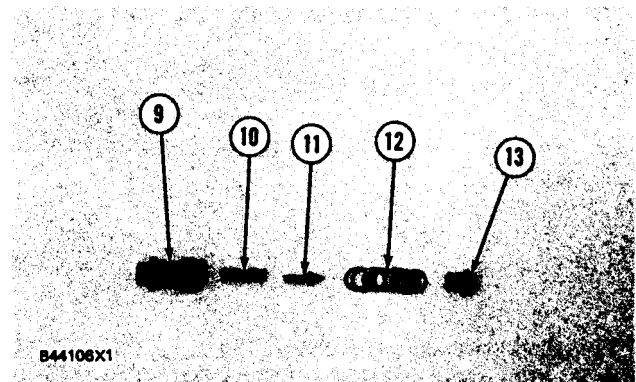

B44106X1

PILOT AND HYDRAULIC PUMP

8. Remove plate (20), O-ring seal (19) and rotor assembly (18) from ring (17).

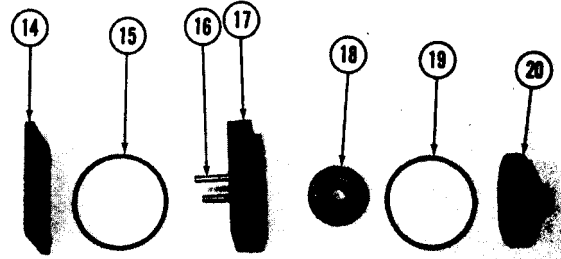

B44107X1

9. Remove plate (14) and dowels (16) from ring (17).

10. Remove O-ring seal (15) from plate (14).

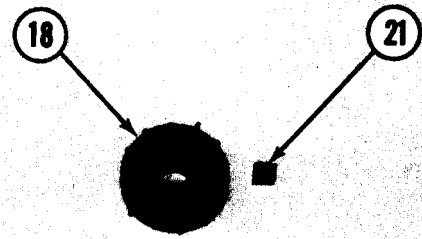

B44108X1

11. Remove vanes (21) from rotor assembly (18).

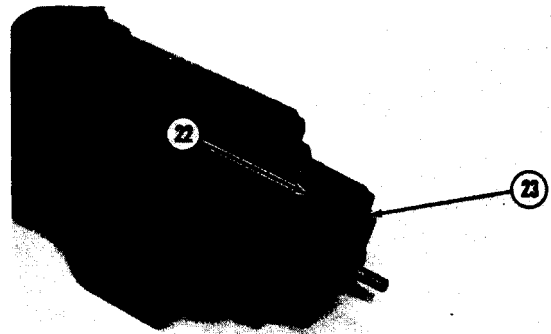

B44109X1

12. Remove bolts (22) and make a separation of cartridge assembly (23) from the cover group.

NOTE: Make a note of the direction of the arrows at locations (X) and (Y) and the location of bolts (24) for assembly purposes.

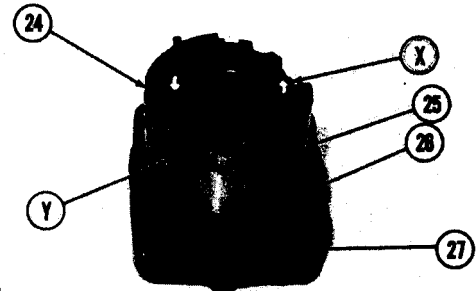

B44110X1

13. Remove cartridge (25) and O-ring seal (26) from body (27).

PILOT AND HYDRAULIC PUMP

14. Remove seal ring (28) from body (27).

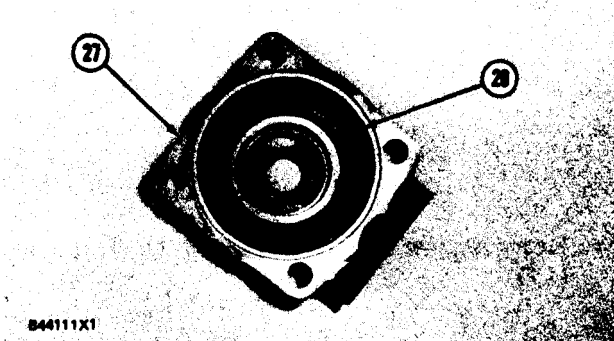

15. Remove backup seal (29) and O-ring seal (30) from the cartridge.

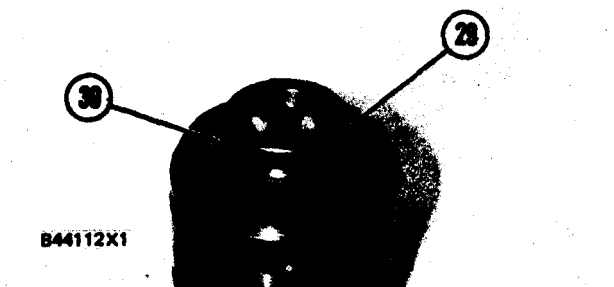

16. Remove bolts (24) and cover (30) from the cartridge.

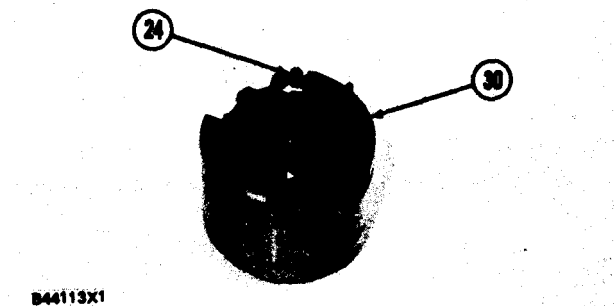

17. Remove seals (31) from cover (30).

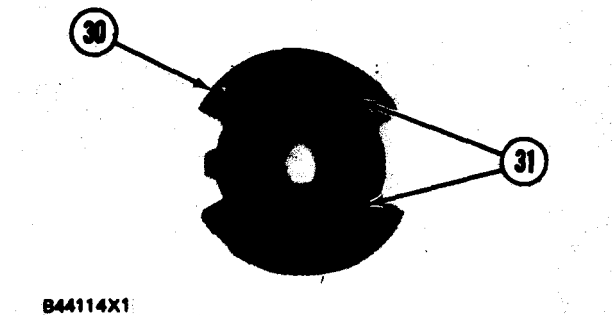

PILOT AND HYDRAULIC PUMP

18. Remove plate (32) from the cartridge.

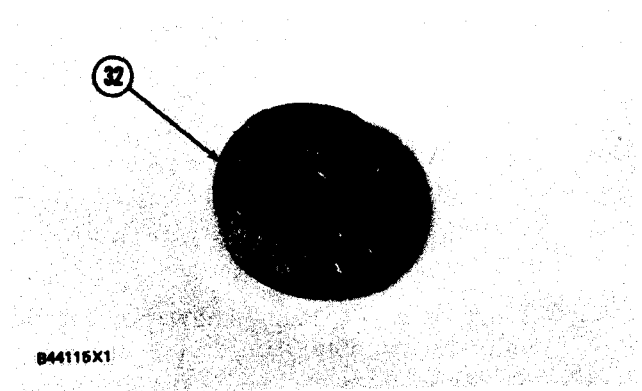

19. Remove ring (33) and rotor assembly (34) from the plate.

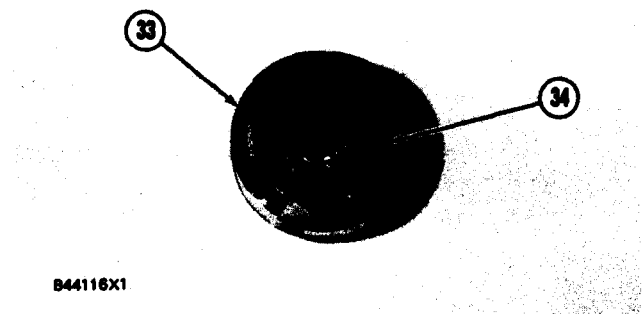

20. Remove vanes (36) and inserts (35) from the rotor.

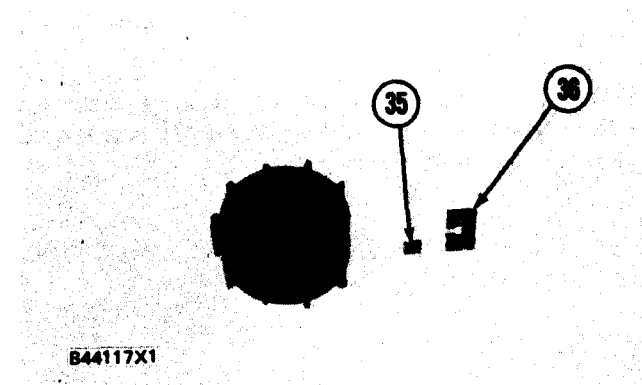

22. Remove plate (37) from end plate (38).

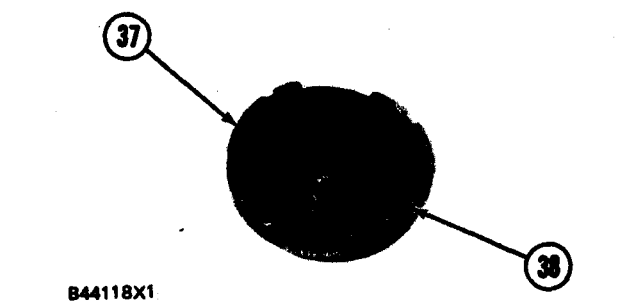

PILOT AND HYDRAULIC PUMP

23. Remove seals (39) from end plate (38).

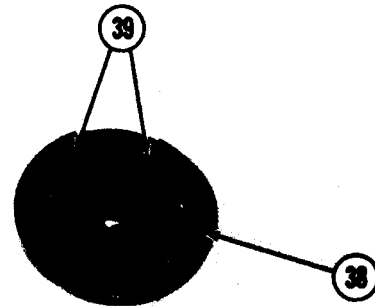

B44119X1

24. Remove bolts (41) and remove housing (40) from body assembly (42).

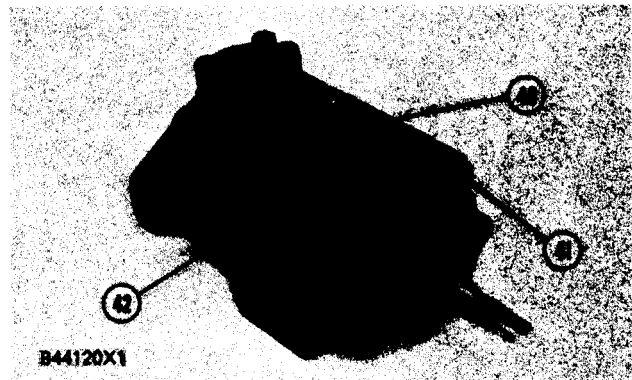

B44120X1

25. Remove cartridge assembly (43) from shaft (44).

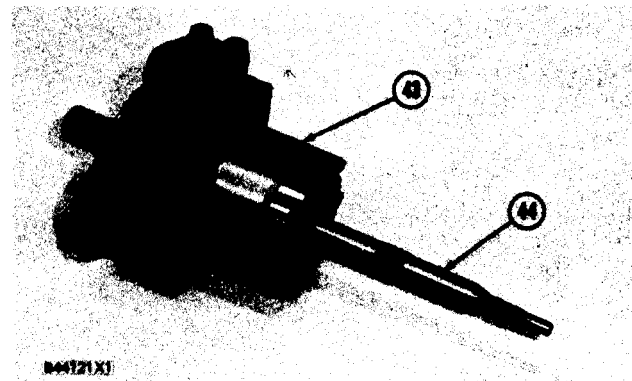

B44121X1

NOTE: Make a note of the direction of the arrows nearest the bolts and the direction of the arrow on the ring for assembly purposes.

26. Do Steps 16 through 23 again for the disassembly of cartridge (43).

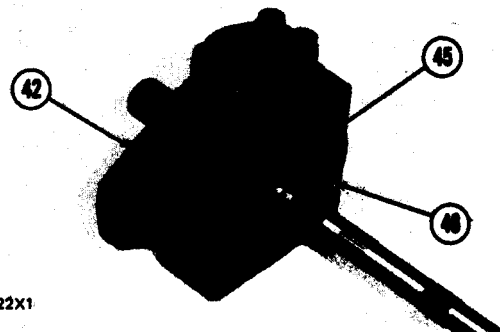

B44122X1

27. Remove seal ring (45) and O-ring seal (46) from body assembly (42).

PILOT AND HYDRAULIC PUMP

28. Remove spiral ring (47) and remove shaft assembly (44) from the housing.

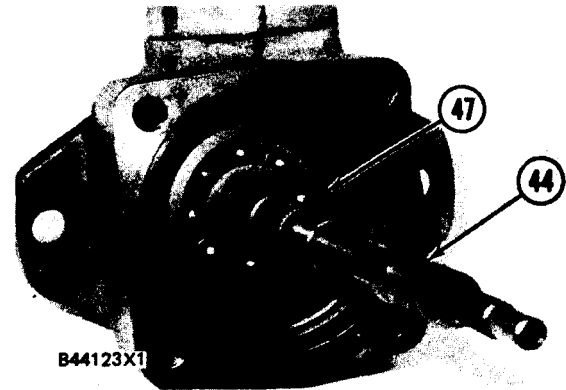

29. Use tooling (A) to remove snap ring (49) and bearing (48) from the shaft.

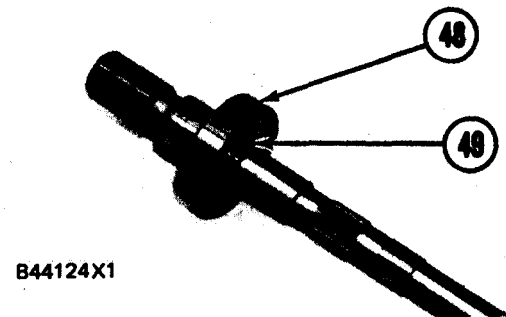

30. Remove washer (51) and lip type seal (50) from the housing.

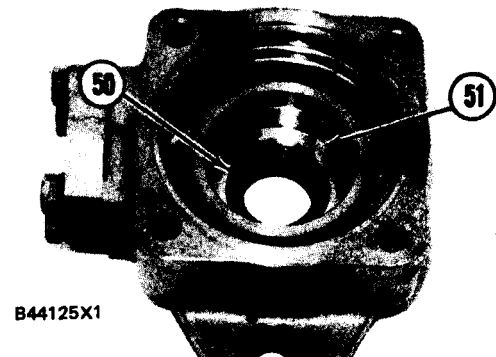

31. Remove lip type seal (52) from the housing.

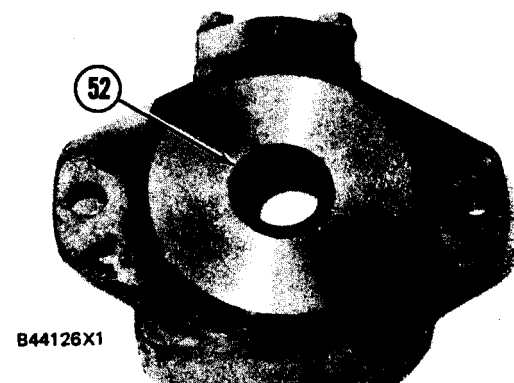

PILOT AND HYDRAULIC PUMP

ASSEMBLE PILOT AND HYDRAULIC PUMP

5073-16

Tools Needed		A	B
1P510	Driver Group	1	
1P1859	Snap Ring Pliers		1

1. Inspect all parts for wear or damage. Make replacements if necessary. Put clean oil on all parts of assembly.

NOTE: For correct assembly of the parts the pump rotation is in a clockwise direction as seen from the pilot end of the hydraulic pump.

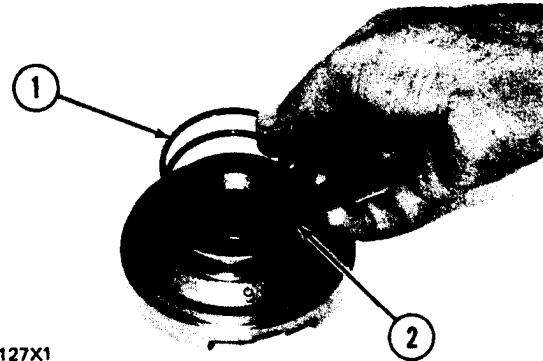

B44127X1

2. Install O-ring seal (2) and then seal ring (1) on the end plate.

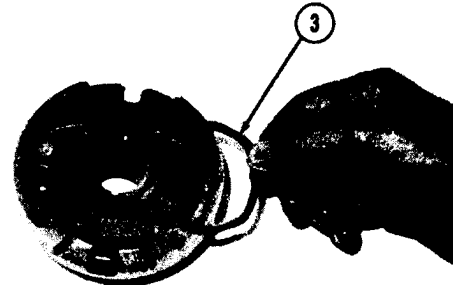

B44128X1

3. Put the O-ring seals in position in the plastic seals. Install seal assemblies (3) on the end plate with the O-ring seal toward the plate.

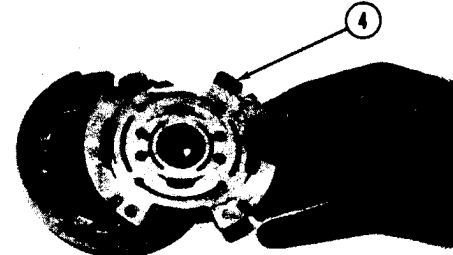

B44129X1

4. Put plate (4) in position so the brass side is toward the rotor.

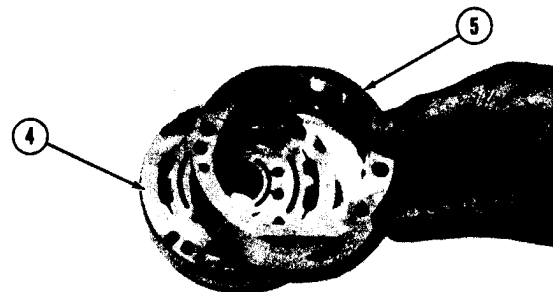

B44130X1

5. Put ring (5) on plate (4) as shown. The arrow on the chamfer of ring (5) must be in the same direction of the rotation of the rotor.

PILOT AND HYDRAULIC PUMP

6. Install inserts (7) and vanes (8) in rotor (6).
The sharp edge of the vanes must be in the same direction as the arrow on the rotor.

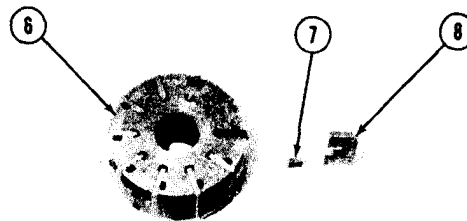

B44131 X1

7. Put rotor assembly (9) in position in ring (5).
Make sure that the sharp edge of the vanes and the arrow on the chamfer are in the same direction.

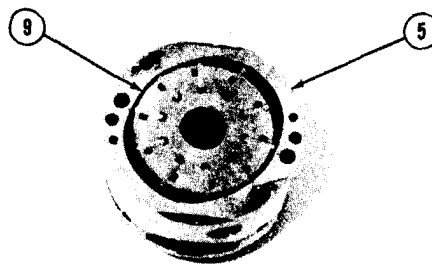

B44132 X1

8. Put plate (10) in position on the cartridge assembly. Make sure the brass side of the plate is toward the rotor assembly. Also make sure the notches on outside diameters of plates (4) and (10) are in alignment. Make an alignment of these notches with the chamfers on ring (5).

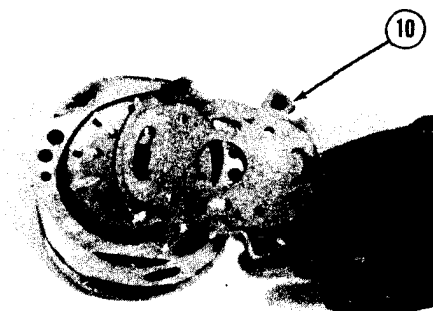

B44133 X1

9. Put the O-ring seals in position in the plastic seals. Install seal assemblies (11) on plate (12) with the O-ring side of seal toward plate (12).

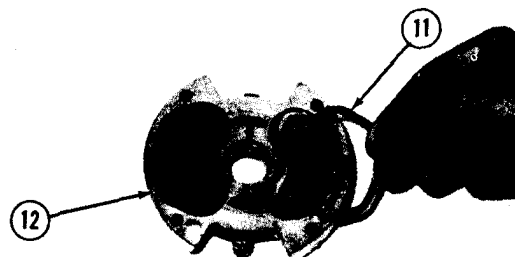

B44134 X1

PILOT AND HYDRAULIC PUMP

10. Install plate (12) on the cartridge assembly as shown. Install bolts (13) in the holes nearest to the arrows on the plate that show the direction of rotation of the pump.

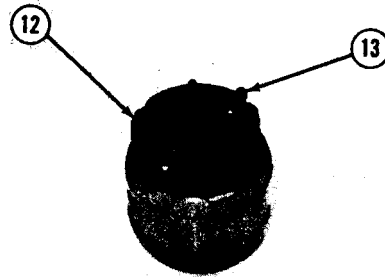

B44135X1

11. Use tool (A) to install the lip type seal in body (14). Install the seal with the lip down as shown.

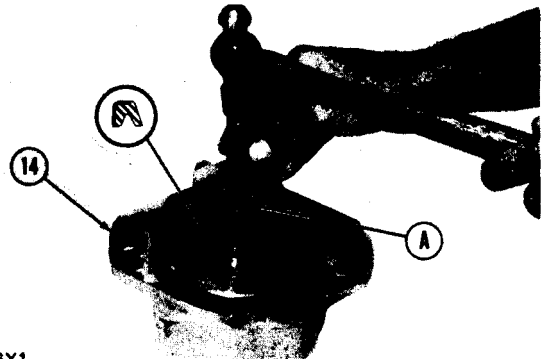

B44136X1

12. Turn body (14) over and install the lip type seal with tooling (A). Make sure the lip of the seal is toward the cartridge assembly.

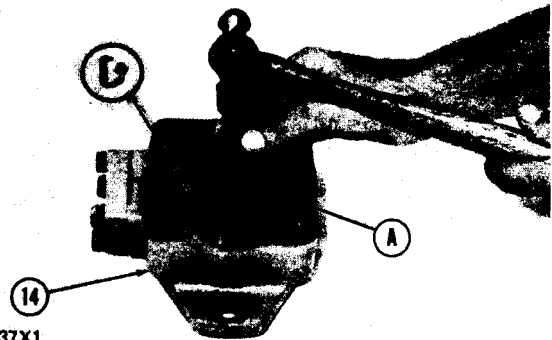

B44137X1

13. Install washer (15) in the body.



B44138X1

PILOT AND HYDRAULIC PUMP

14. Install bearing (16) on shaft (18).

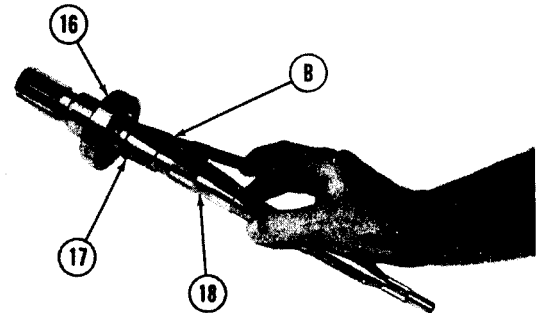

B44139X1

15. Use tool (B) to install snap ring (17) on shaft (18) that holds the bearing in place.

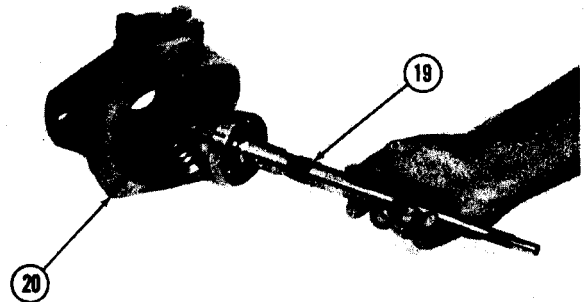

B44140X1

16. Put shaft assembly (19) in position on body assembly (20).

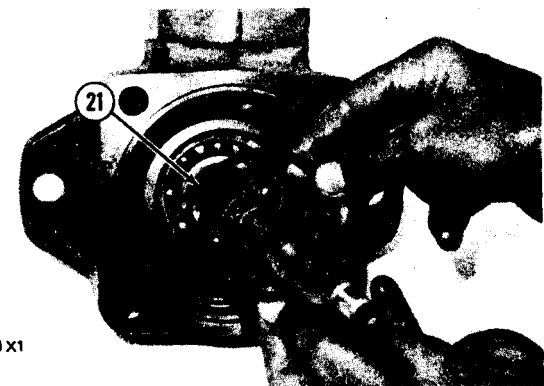

B44141X1

17. Install spiral ring (21) that holds the shaft assembly in place.

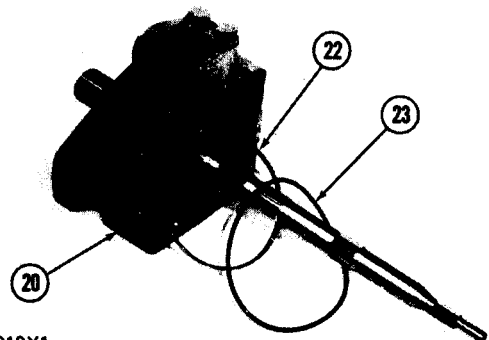

B44919X1

18. Install seal ring (22) and O-ring seal (23) on body assembly (20).

PILOT AND HYDRAULIC PUMP

19. Install cartridge assembly (9) on the shaft assembly.

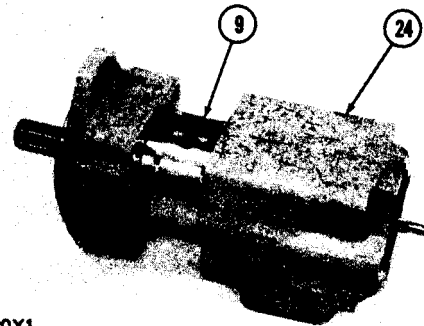

20. Make an alignment of the dowels in the cartridge and the holes in the housing. Install housing (24) on the body.

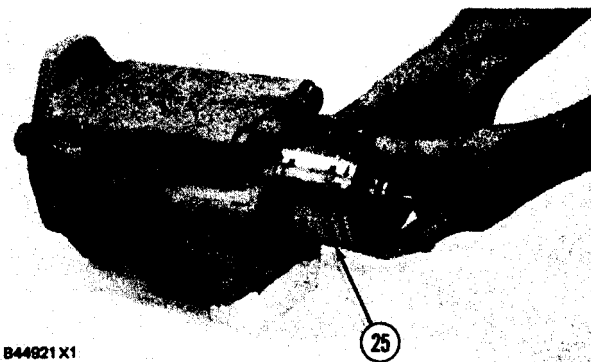

21. Install the bolts that hold the housing to the body and tighten them to a torque of 203 ± 14 N-m (150 ± 10 lb. ft.).

22. Do Steps 1 through 10 again for the assembly of cartridge (25).

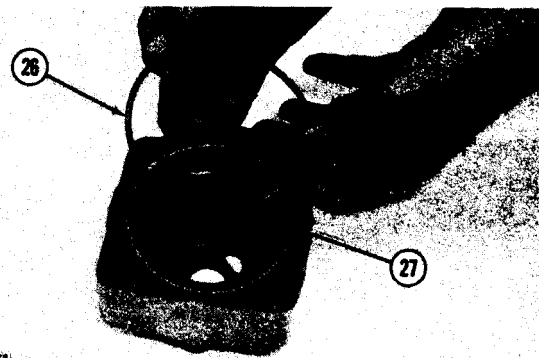

23. Install cartridge (25) in the cover group as shown.

24. Install seal ring (27) and O-ring seal (26) in the body.

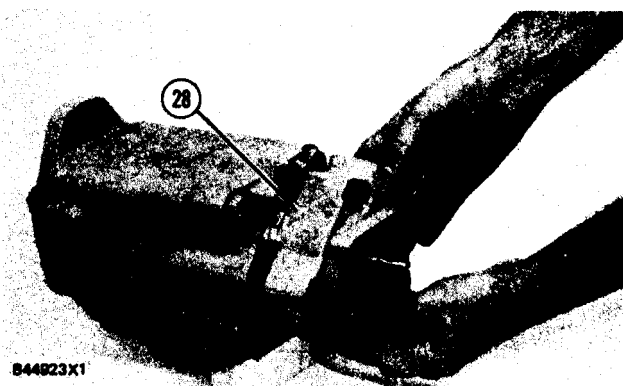

25. Install body (28) on the cover group. Install the bolts and tighten them to a torque of 95 ± 7 N-m (70 ± 5 lb. ft.).

PILOT AND HYDRAULIC PUMP

26. Install O-ring seal (29) on the body.

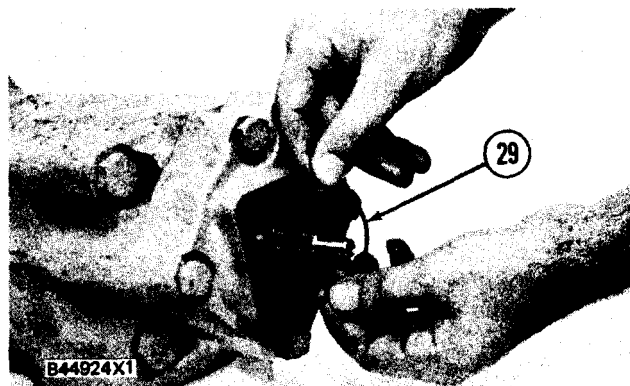

27. Install dowels (30) in the body.

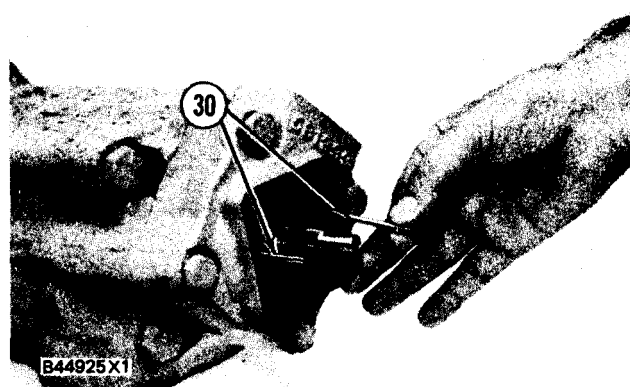

28. Install adapter (31) on the dowels as shown.

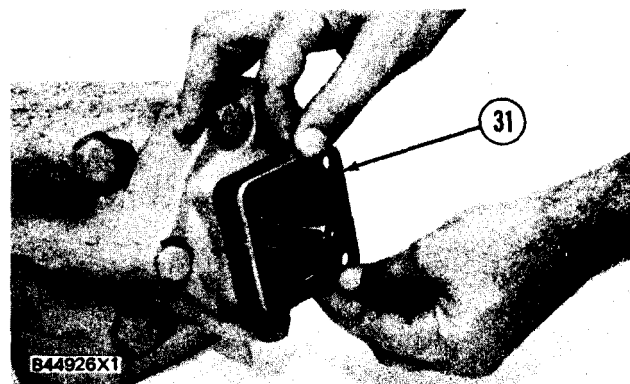

29. Install O-ring seal (32) on the adapter.

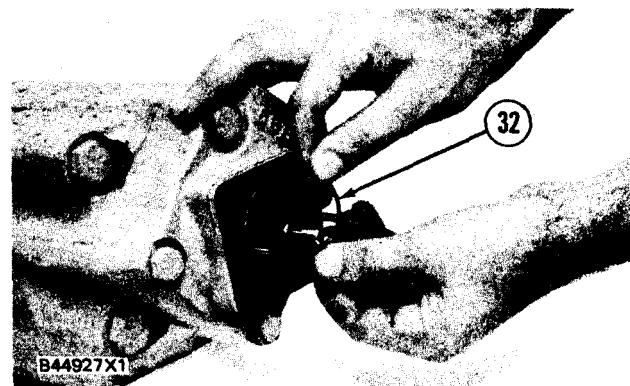

PILOT AND HYDRAULIC PUMP

30. Install ring (33) on the dowels. Make sure the arrows on the outer edge of the ring are in the same direction as the rotation of the pump.

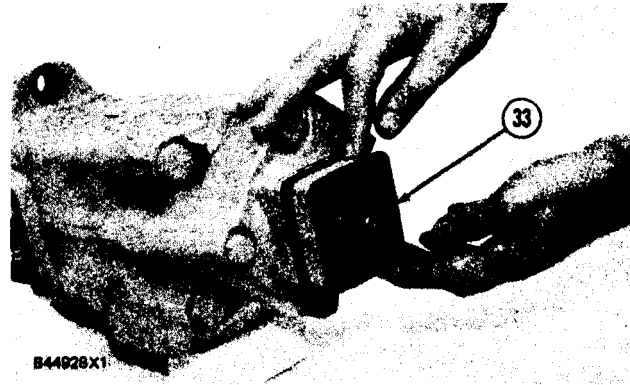

31. Install vanes (35) in rotor (34). Make sure the vanes are installed so the rounded edge is to the outside.

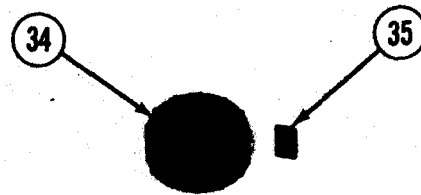

B44929X1

32. Install rotor assembly (36) on the shaft in the ring.

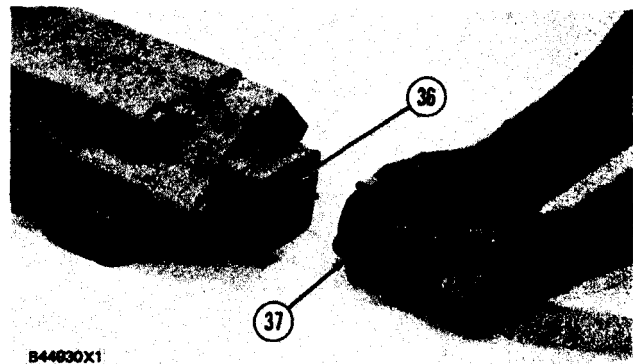

33. Install plate (37) on the dowels.

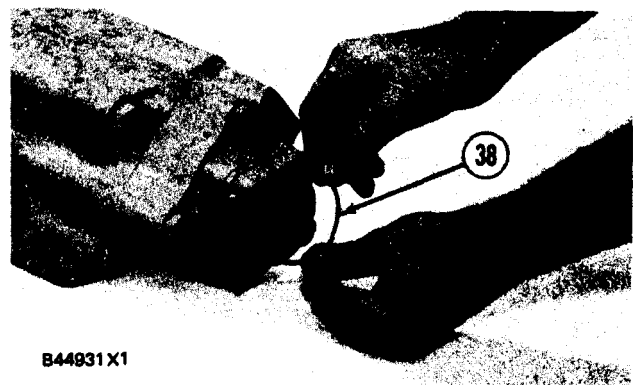

34. Install O-ring seal (38) on the plate.

PILOT AND HYDRAULIC PUMP

35. Install spring (39) on the plate.

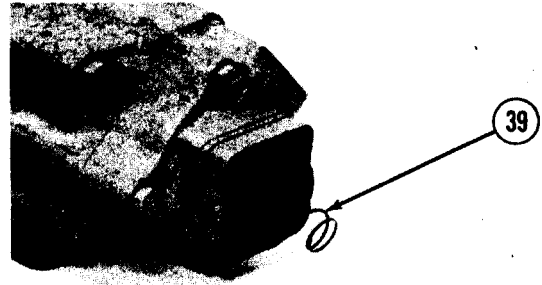

B44932X1

36. Install spring (41), valve (42), shims (43) and bolt (44) in valve spool (40).

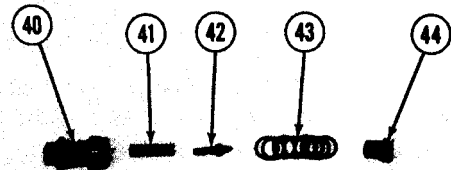

B44933X1

37. Install O-ring seal (47) on plug (48).

38. Install spool assembly with screen (45), spring (46) and plug (48) in cover (49).

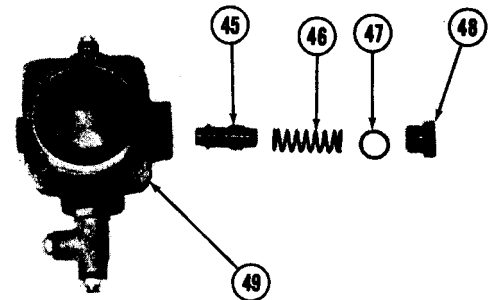

B44105X2

39. Install cover assembly (50) on the pump group. Tighten the bolts to a torque of 55 ± 7 N-m (40 ± 5 lb. ft.).

40. Install O-ring seal (51) on the body end by:
a) install pilot and hydraulic pump

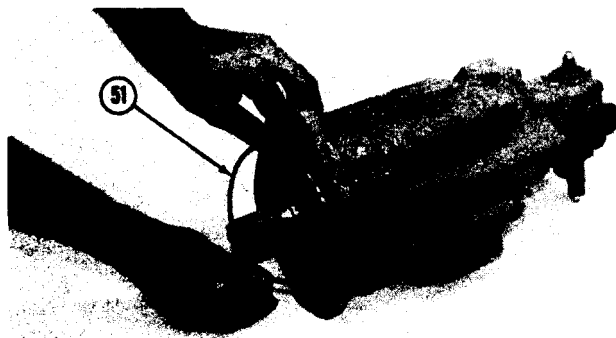

B44935X1

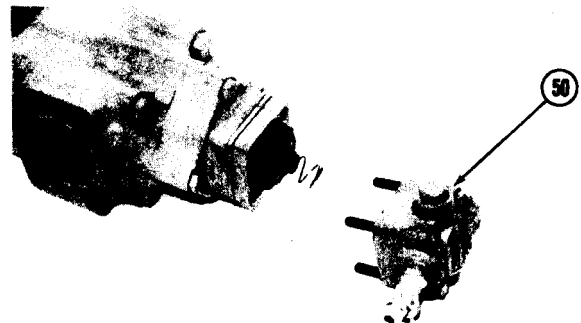

B44934X1

HYDRAULIC OIL FILTERS

REMOVE HYDRAULIC OIL FILTERS 5068-11

WARNING

To prevent personal injury release the pressure from the hydraulic system before any lines are removed or disconnected.

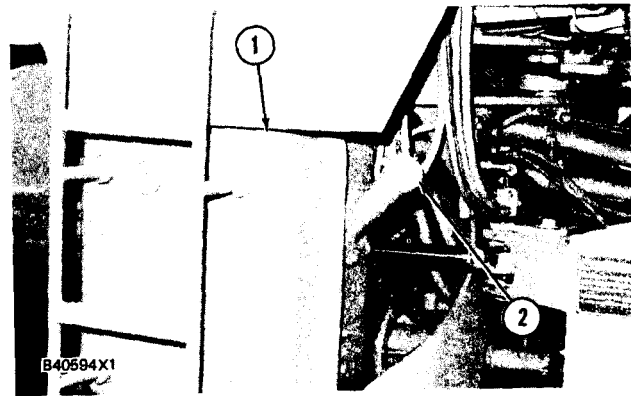

1. Remove hydraulic tank filler cap (2) slowly to release any pressure in the hydraulic tank (1).

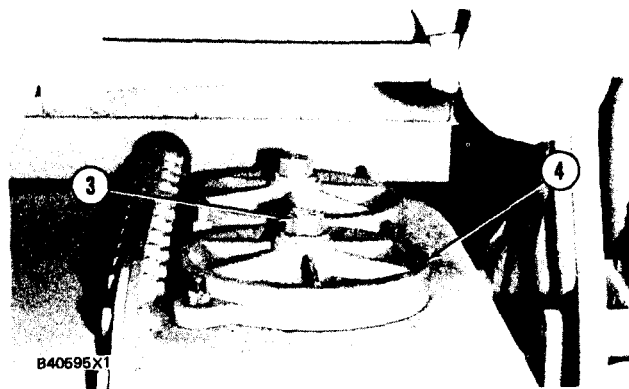

2. Loosen bolt (3).

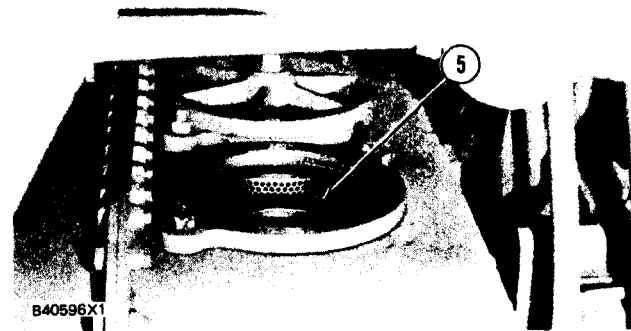

3. Remove cover (4) and element assembly (5) from the hydraulic tank.

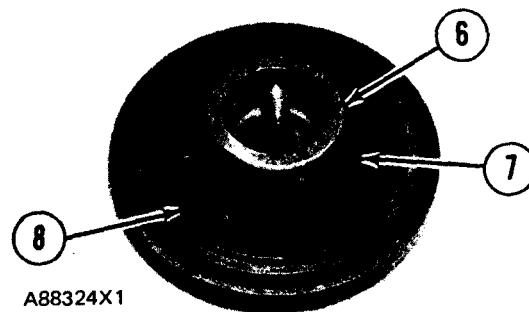

4. Remove spiral lockring (6). Remove spacer (7) and six springs (8) from the cover.

HYDRAULIC OIL FILTERS

5. Remove spiral lockring (10). Remove bolt (3) from the cover. Remove the O-ring seal from the bolt.
6. Remove O-ring seal (9).
7. Do Steps 2 through 6 for the other filter.

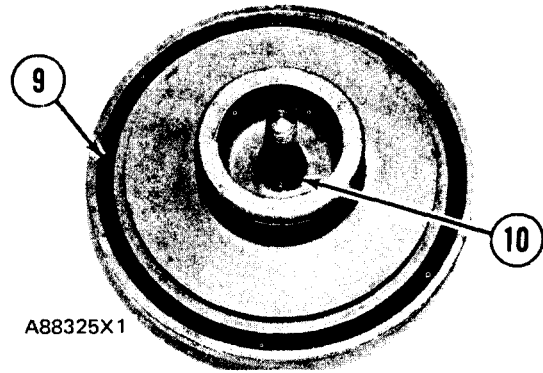

INSTALL HYDRAULIC OIL FILTERS 5068-12

1. Install O-ring seal (1) on the bolt.
2. Install bolt (2) in the cover. Install the spiral lockring that holds it.
3. Install O-ring seal (6) on the cover.
4. Install six springs (5). Install the springs in pairs with the outside diameters in contact with each other.
5. Install spacer (4) and spiral lockring (3) on the cover.
6. Install element assembly (7) in the hydraulic tank.
7. Install cover (8) on the hydraulic tank.
8. Do Steps 1 through 7 for the other filter.

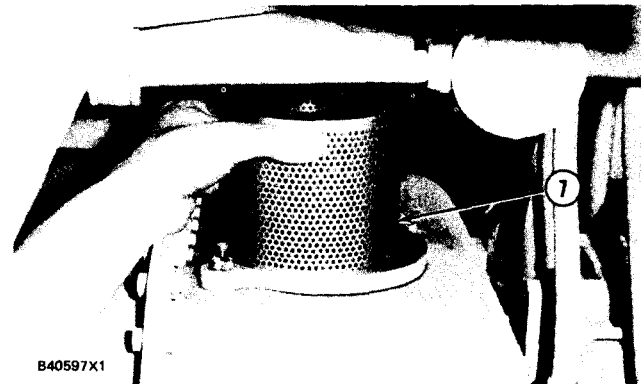
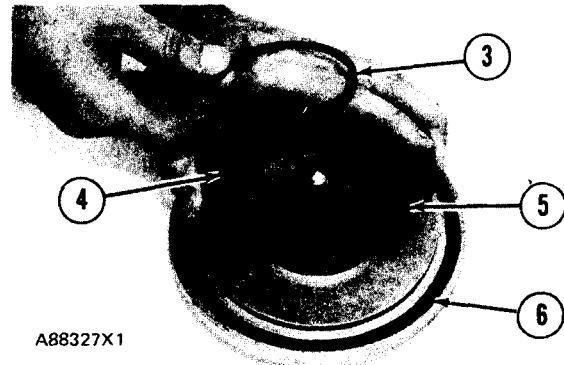
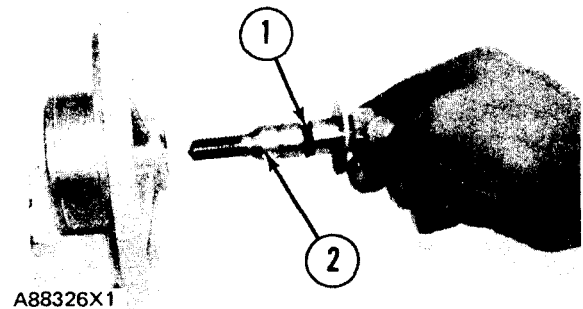

HYDRAULIC TANK

REMOVE HYDRAULIC TANK

5056-11

Tools Needed		A
5P9736	Link Bracket	2

start by:

- a) connection of anti-pivot link

WARNING

To prevent personal injury stop the engine, lower the bucket to the ground, move the control levers backward and forward to release the pressure in the hydraulic system. Slowly loosen the cap to release any pressure in the hydraulic tank. Let the hydraulic oil become cool before any lines are disconnected in the hydraulic system.

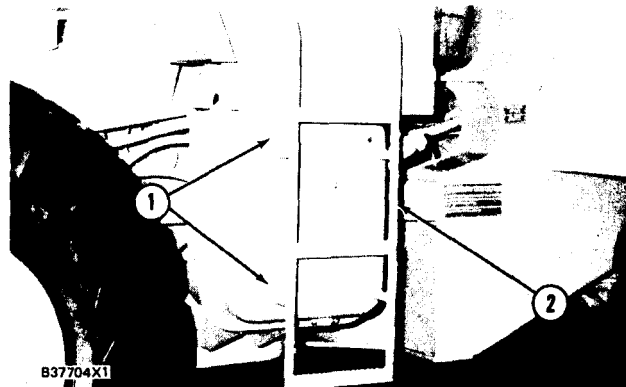

1. Drain the oil from the hydraulic tank.
2. Remove bolts (1) and ladder assembly (2) from the side of the hydraulic tank,
3. Drain the air from the system. Disconnect air line (3) from the air horn assembly.
4. Fasten tooling (A) and a hoist to platform assembly (4).
5. Remove bolts (5) that hold the bottom of the platform assembly to the machine.

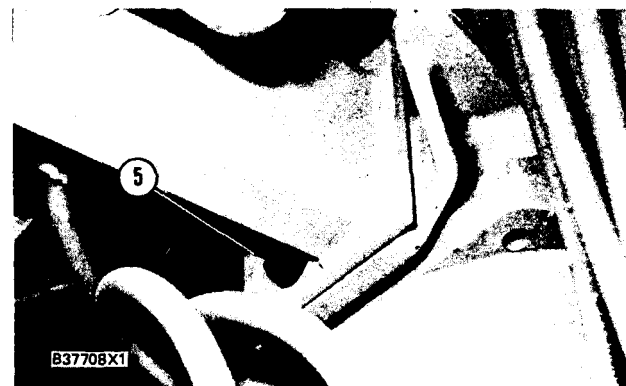
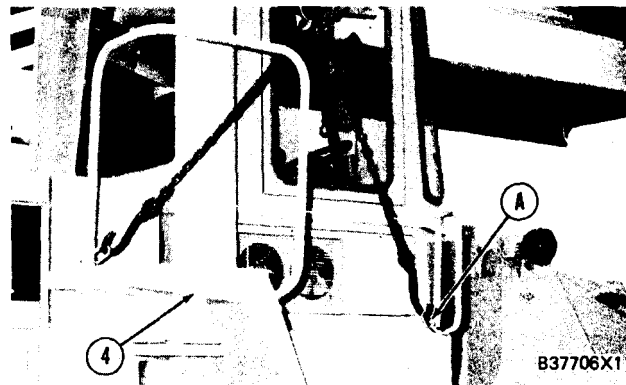

HYDRAULIC TANK

- Remove bolts (6) that hold the platform to the machine and remove the platform. The weight of the platform is 65 kg (143 lb.).



- Fasten tooling (A) and a hoist to hydraulic tank (7).

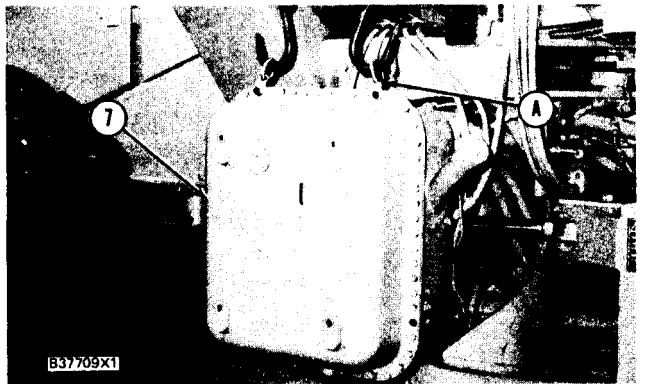

- Disconnect wires (8) and tube assembly (9) from the hydraulic tank.

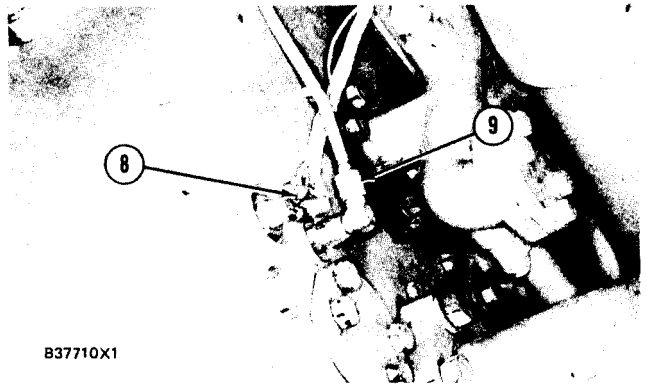

- Remove bolts (10) that hold elbows (11) to the hydraulic tank.

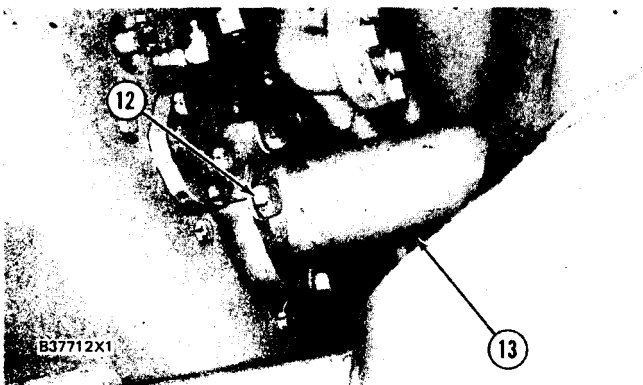
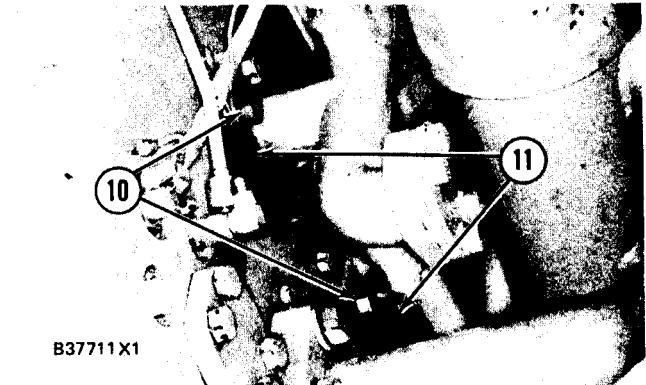

HYDRAULIC TANK

11. Remove three bolts (15) that hold the steering control valve (14) to the hydraulic tank.

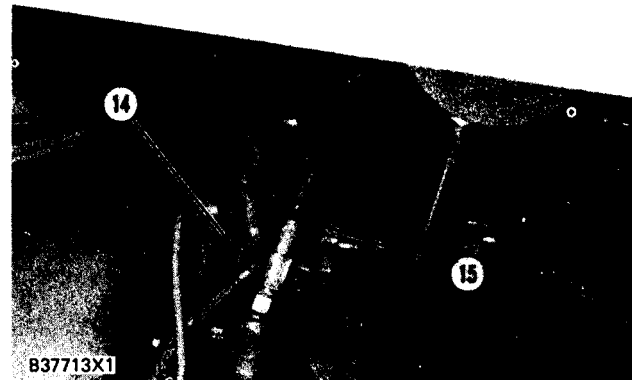

12. Remove bolts (16) that hold the hydraulic tank to the bracket on the machine.

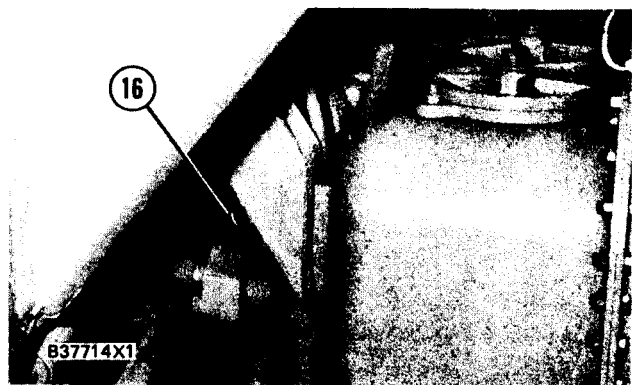

13. Remove bolts (17) that hold the hydraulic tank to the bracket on the machine. Remove the hydraulic tank. The weight of the hydraulic tank is 100 kg (220 lb.).

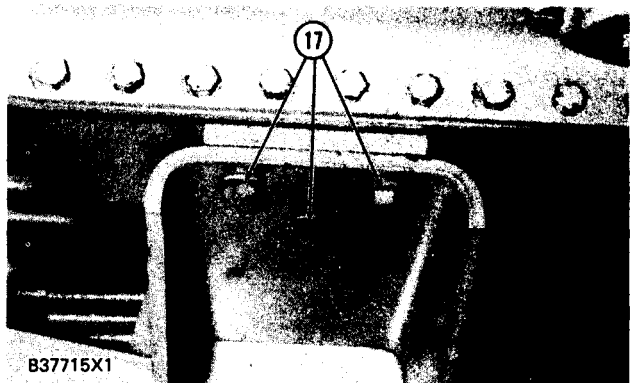

INSTALL HYDRAULIC TANK

5056-12

	Tools Needed	A
5P9736	Link Bracket	2

1. Check O-ring seals (2) for wear or damage. If necessary, make a replacement.

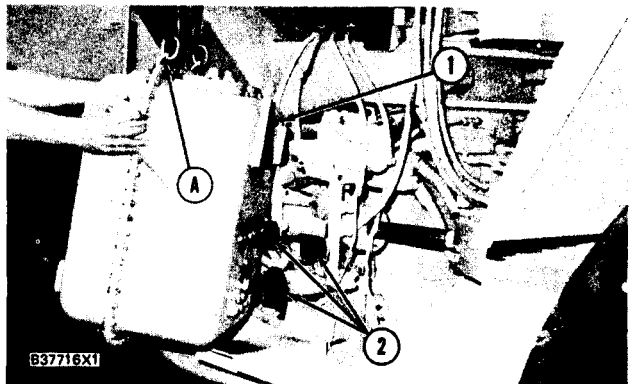

2. Fasten tool (A) and a hoist to hydraulic tank (1). Put the hydraulic tank in position on the machine.

HYDRAULIC TANK

3. Install bolts (3) that hold the hydraulic tank to the bracket on the machine.

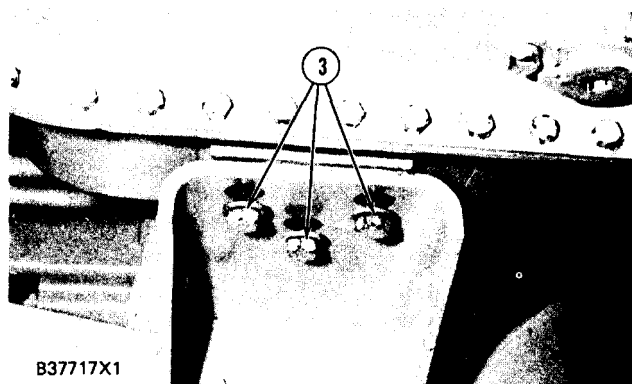

4. Install bolts (4) that hold the hydraulic tank to the bracket on the machine.

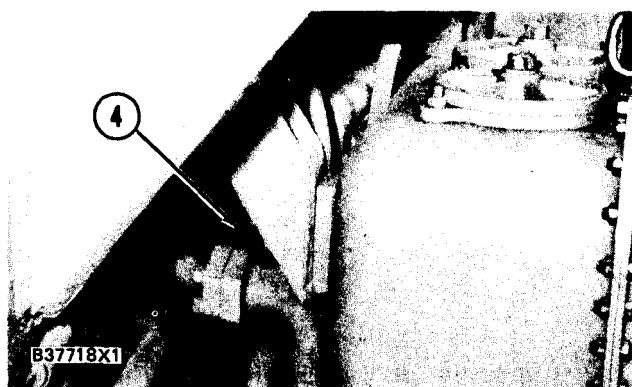

5. Connect tube assembly (5) to the back of the machine.

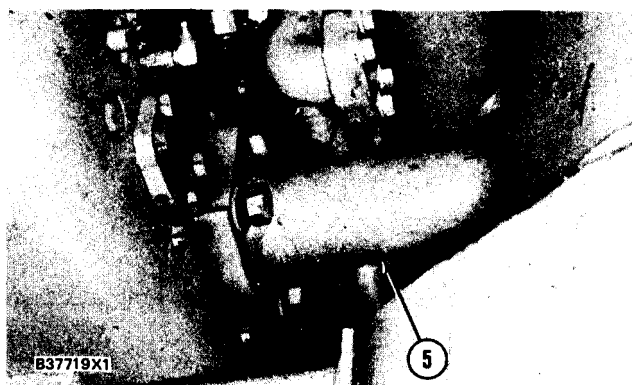

6. Connect elbows (6) to the back of the hydraulic tank.

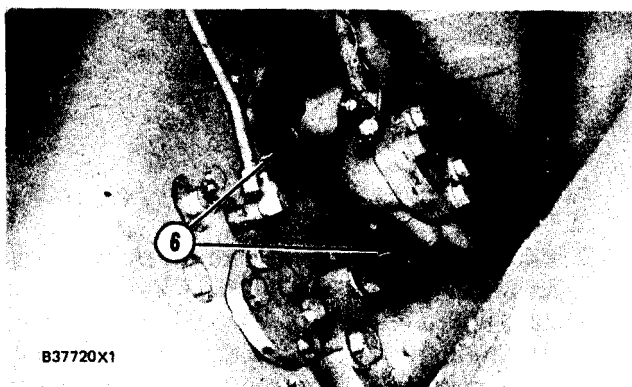

7. Fasten steering control valve (7) to the hydraulic tank with bolts (8).



HYDRAULIC TANK

8. Connect the wire assembly (9) and tube assembly (10) to the back of the hydraulic tank.



9. Put platform (11) in position on the machine with tooling (A) and a hoist.

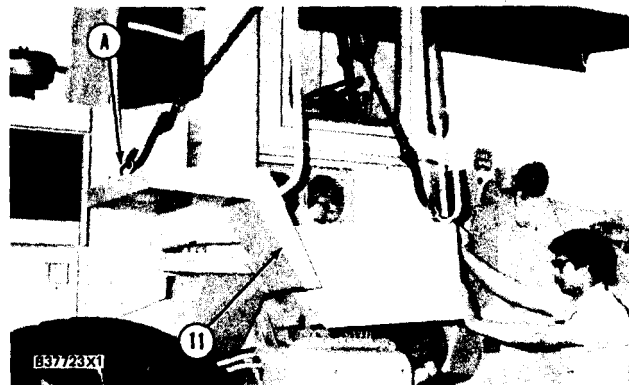

10. Connect air line (12) to the air horn assembly.



11. Install ladder assembly (13) on hydraulic tank (1).

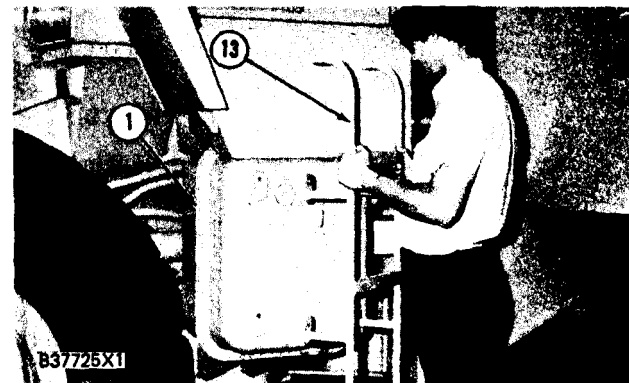

12. Fill the hydraulic tank with oil to the correct level. See OPERATOR'S MANUAL.

end by:

- a) separation of anti-pivot link

HYDRAULIC TANK

DISASSEMBLE HYDRAULIC TANK 5056-15

Tools Needed		A
5P9736	Link Bracket	2

start by:

a) remove hydraulic tank

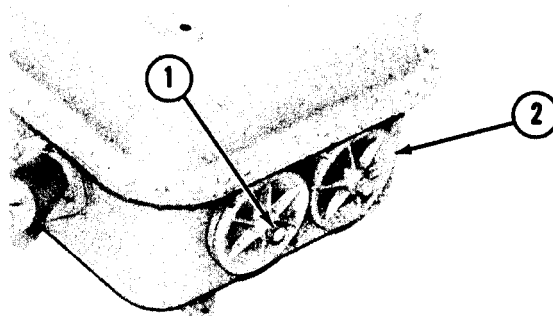

B40599X1

1. Loosen bolts (1) and remove covers (2) from the hydraulic tank.

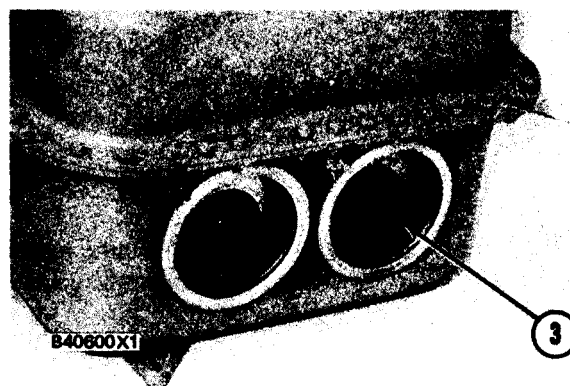

B40600X1

2. Remove filter elements (3) from the hydraulic tank.

3. Fasten tooling (A) to the cover assembly as shown. Remove bolts (4) and the nuts that hold the cover assembly to the tank assembly.

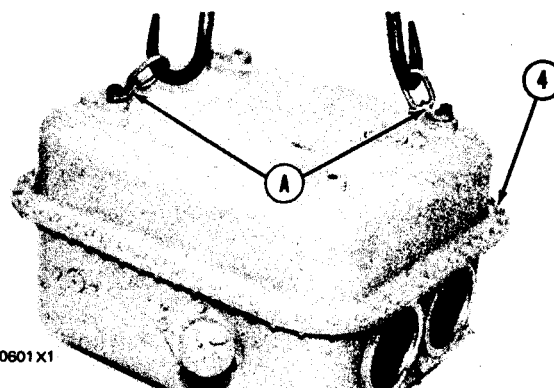

B40601X1

4. Remove the cover assembly. The weight of the cover is 34 kg (75 lb.).

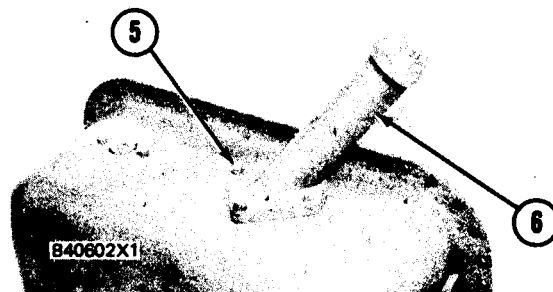

B40602X1

5. Remove bolts (5) and remove filler assembly (6) from the tank assembly.

HYDRAULIC TANK

6. Remove cap assembly (7) and the strainer from the filler assembly.

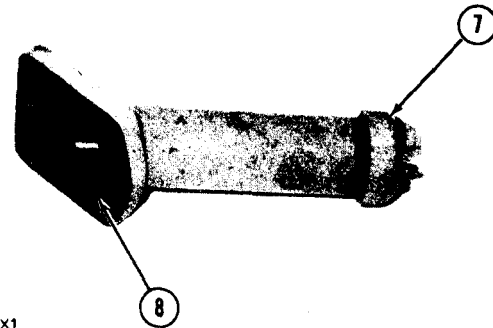

B40603X1

7. Remove O-ring seal (8) from the filler assembly.

8. Remove gasket (9), plate (10) and the ball from cap (7).

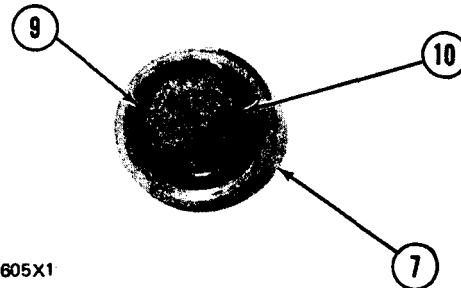

B40605X1

9. Remove bolts (11) slowly and evenly to release the spring tension.

10. Remove plates (12), flanges (13), tube assemblies (14), the springs and the valves from each base.

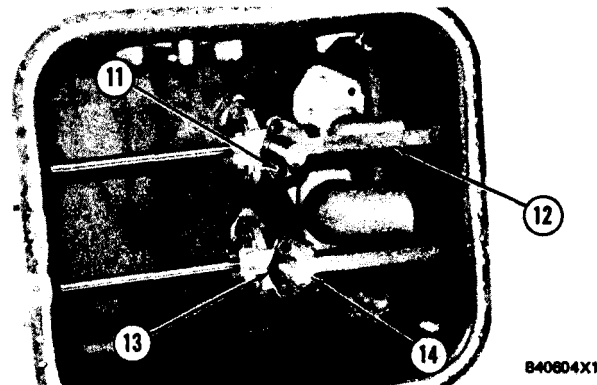

B40604X1

11. Remove the bolts (on the back side of the tank assembly), then remove bases (15).

12. Remove pin (16) and remove rod (17) from both the base assemblies.

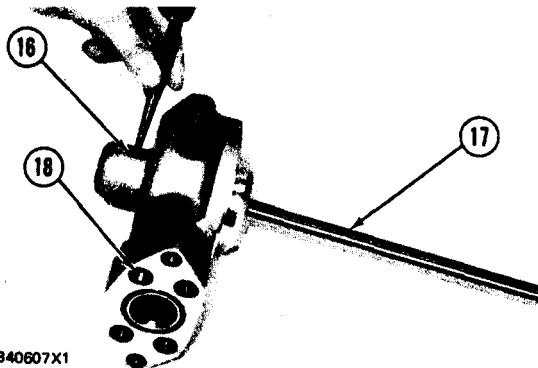

B40607X1

13. Remove O-ring seals (18) from both the base assemblies.

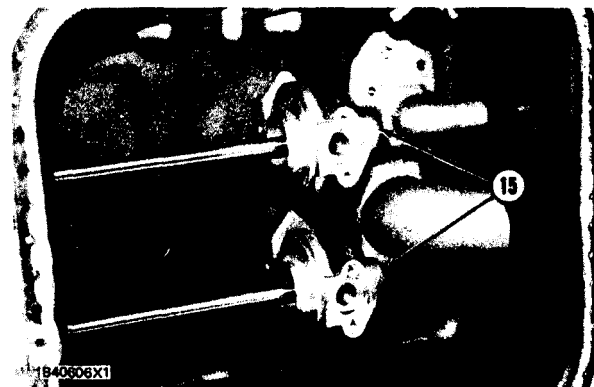

B40606X1

HYDRAULIC TANK

Remove bolts (19) and remove plate (20) and the O-ring seal from the tank assembly.

Remove the bolts (from the back side of the tank assembly), then remove manifold (21) and block (22) from the tank assembly.

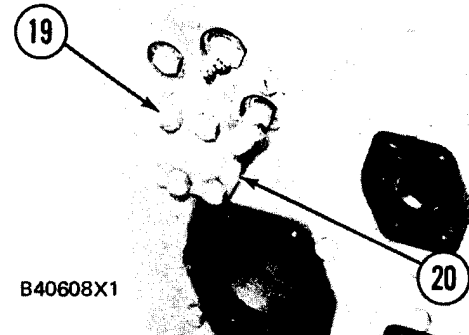

16. Remove the O-ring seals from the back side of the manifold and block.

17. Remove the bolts (from the back side of the tank assembly), then remove blocks (23) and (24) from the tank assembly.

NOTE: On models 950BNSCE and 950BSCE, nuts and washers on welded studs are used in place of bolts (25).

18. Remove bolts (25), body (26), the guide, spring, valve and the seal from the cover assembly.

19. For models 950BNS and 950BS only, remove the bolts (from the back side of the cover assembly) and remove block (27) from the cover assembly.

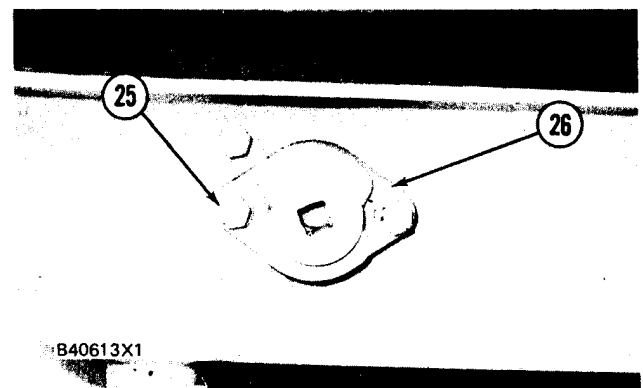
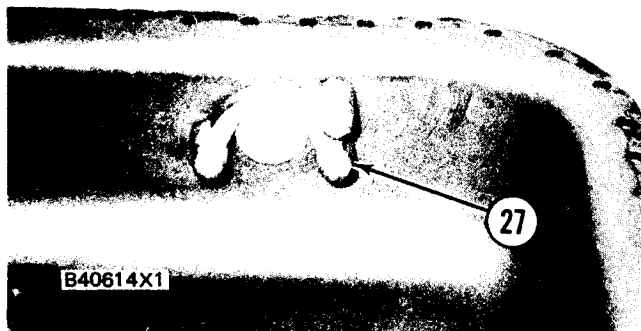
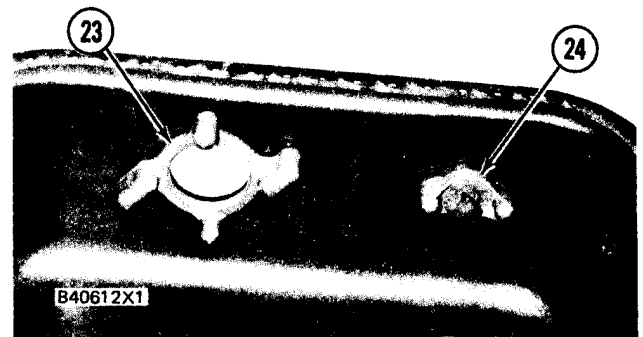
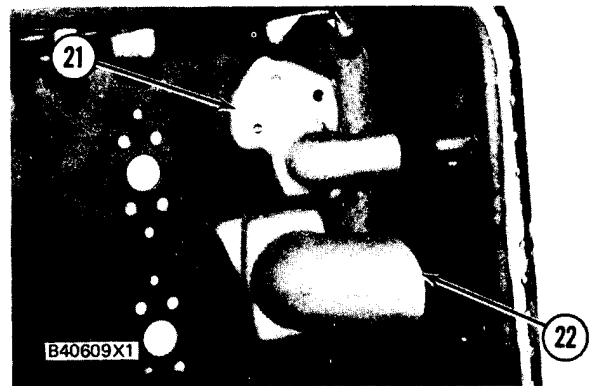

HYDRAULIC TANK

NOTE: Models 950BNSCE and 950BSCE do not use tube assembly (29).

20. Remove the bolts (from the back side of the cover assembly) and remove gauge group (28) and tube assembly (29) from the cover assembly.
21. Remove O-ring seals (33), grommet (30), glass (31) and plate (32) from retainer (34).

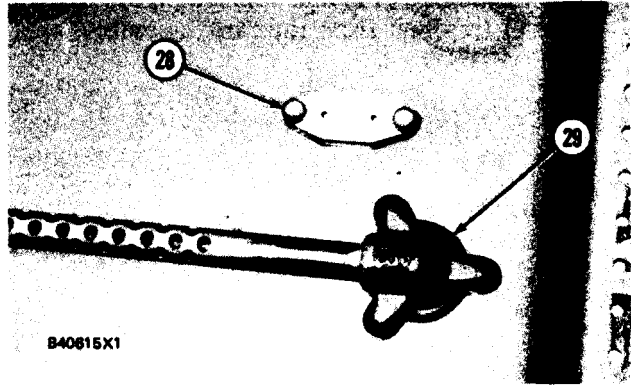

ASSEMBLE HYDRAULIC TANK 5056-16

Tools Needed		A
5P9736	Link Bracket	2

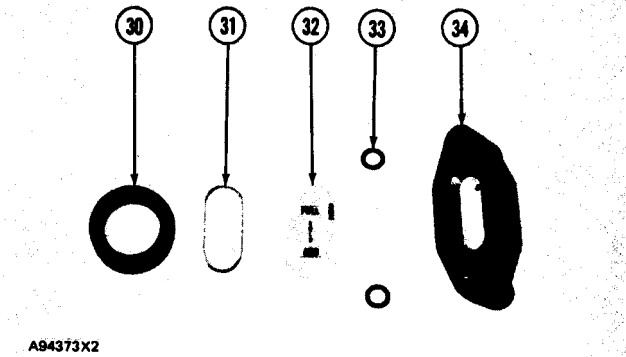

1. Clean and inspect all parts. Make a replacement of all parts that are worn or damaged.
2. Install grommet (2) on glass (3).

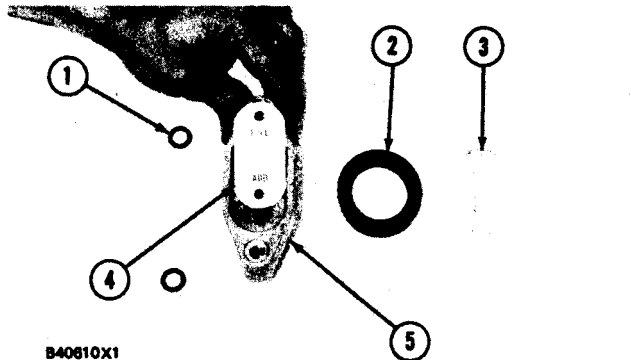

3. Install plate (4), the glass and grommet and O-ring seals (1) on retainer (5).

NOTE: Tube assembly (7) is not used on models 950BNSCE and 950BSCE.

4. Install the O-ring seals on tube assembly (7) and gauge group (6). Install tube assembly (7) and gauge group (6) on the cover assembly. Tighten the bolts that hold the gauge group to a torque of $24 \pm 3 \text{ N}\cdot\text{m}$ ($17 \pm 2 \text{ lb. ft.}$).

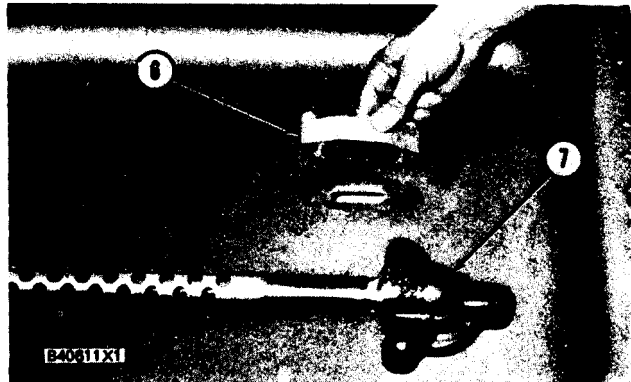

HYDRAULIC TANK

5. For models 950BNS and 950BS only, install O-ring seals (8) on block (9). Install block (9) on the-cover assembly.

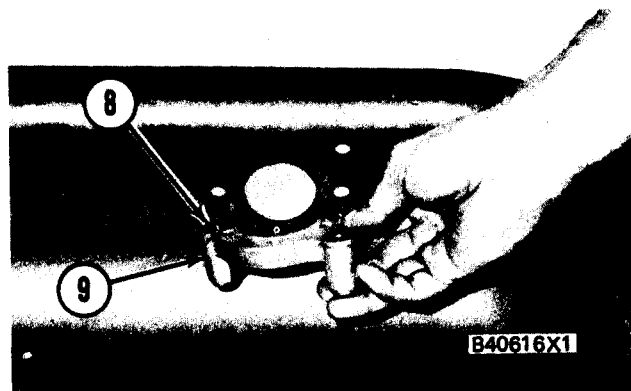

6. Install O-ring seal (15) on plug (16) and install O-ring seal (13) on body (14).

7. Install plug (16) on body (14) and tighten to a torque of $68 \pm 7 \text{ N}\cdot\text{m}$ ($50 \pm 5 \text{ lb}\cdot\text{ft}$).

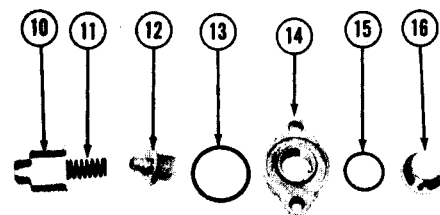

B40617X1

8. Install spring (11) and valve (12) on guide (10).

NOTE: Welded studs, nuts and washers are used in place of bolts on models 950BNSCE and 950BSCE.

9. Install guide assembly (17) and body assembly (18) on the cover assembly.

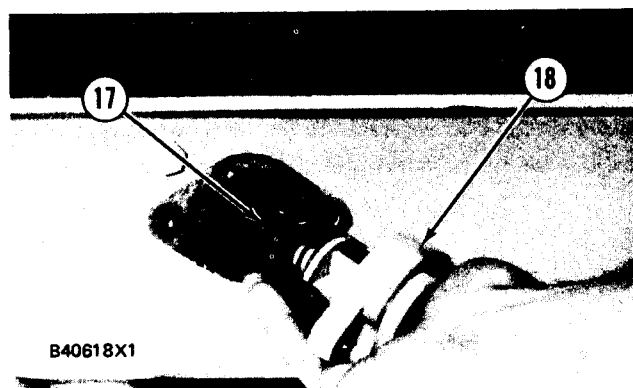

10. Install the O-ring seals on block (19) and O-ring seals (20) on block (21).

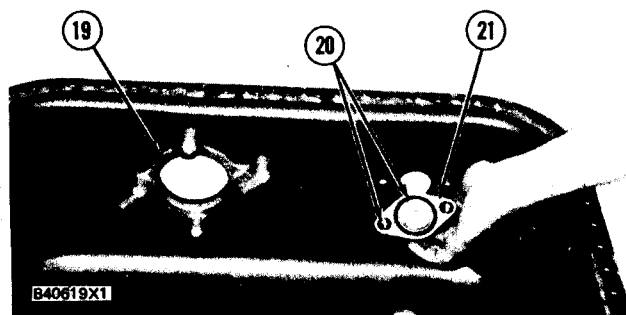

11. Install blocks (19) and (21) on the tank assembly.

HYDRAULIC TANK

12. Install the O-ring seals on block (24) and install O-ring seals (22) in manifold (23).

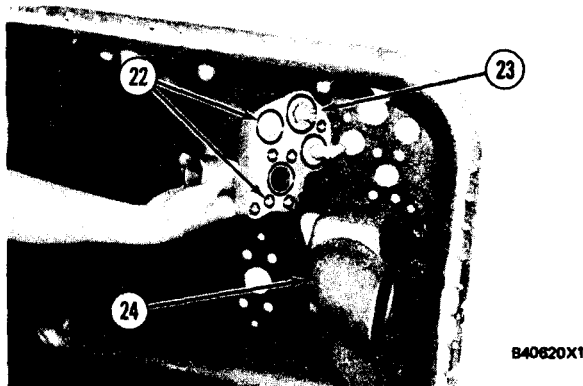

13. Install block (24) and manifold (23) on the tank assembly.

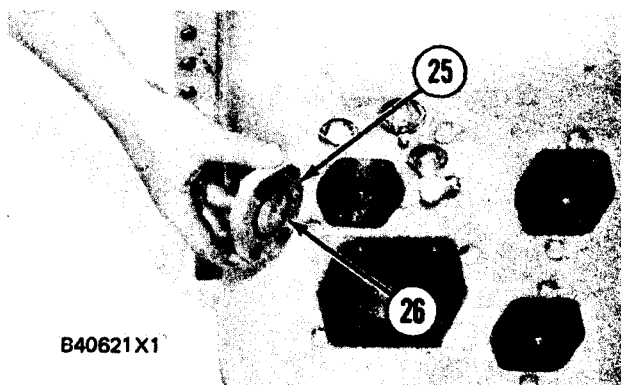

14. Install O-ring seal (26) on cover (25) and install cover (25) on the tank assembly.

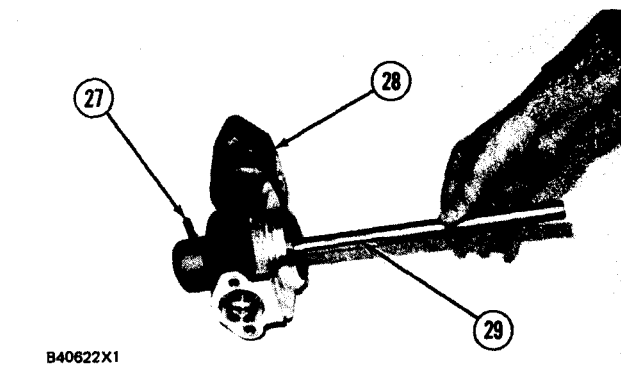

15. Install rod (29) in base (28), Make an alignment of the holes in the rod and base and install pin (27). Do this procedure for the other base.

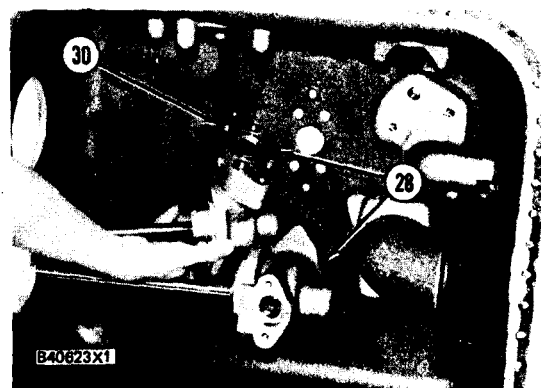

16. Install O-ring seals (30) on bases (28) and install bases (28) on the tank assembly.

HYDRAULIC TANK

17. Install springs (31) and flanges (33) on tube assemblies (32).

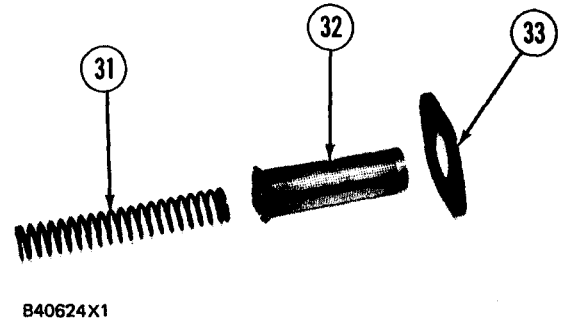

18. Install valves (34) in the base assemblies.

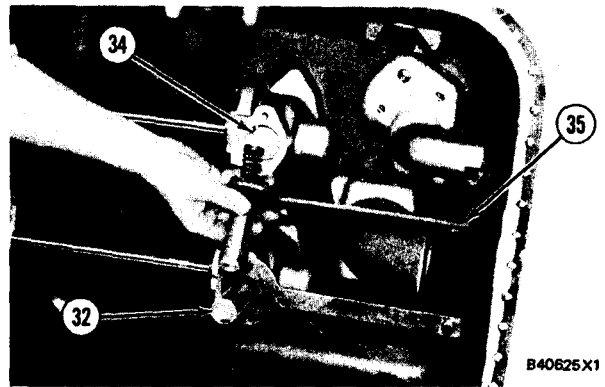

19. Install tube assemblies (32) and plates (35) on the base assemblies.

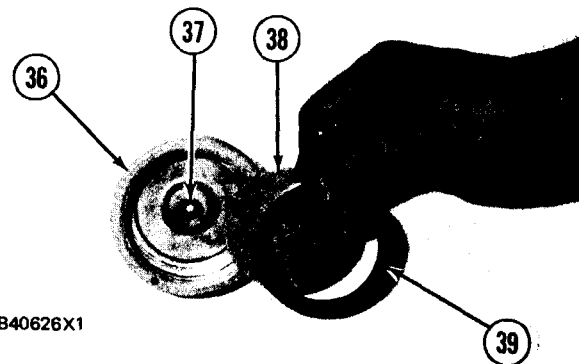

20. Install ball (37), plate (38) and gasket (39) in cap (36).

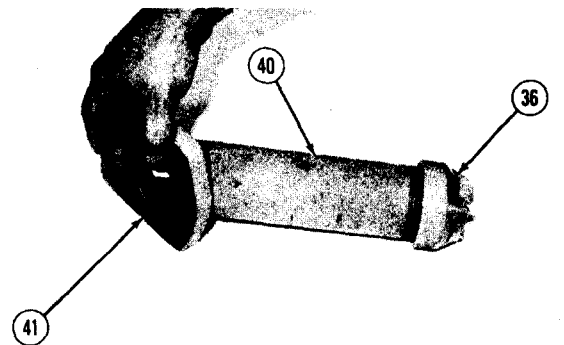

21. Install O-ring seal (41), the strainer and cap (36) on filler assembly (40).

HYDRAULIC TANK

22. Install filler assembly (40) on the tank assembly.

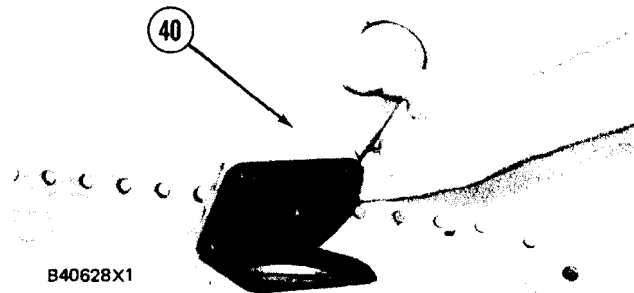

23. Install teflon sealant (41) on the edge of the lower tank assembly to the inside of the bolt holes. Make sure one end of the sealant is over the other end and both ends must be around a bolt hole as shown.

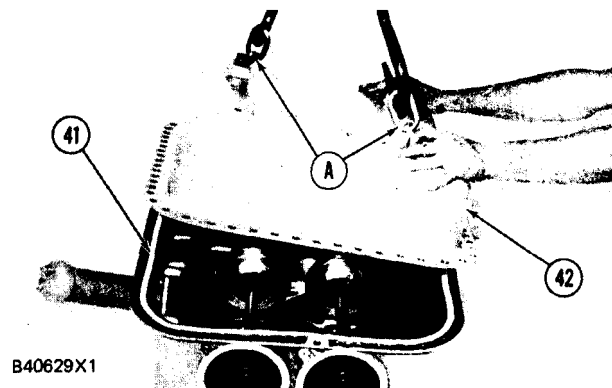

24. Fasten tooling (A) to cover (42) and install the cover on the tank assembly as shown.

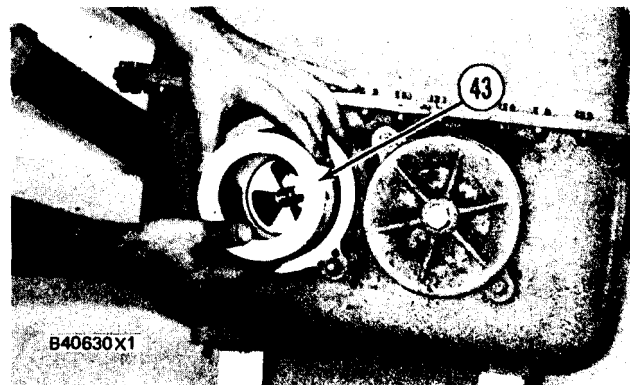

25. Install filter elements (43) in the hydraulic tank.

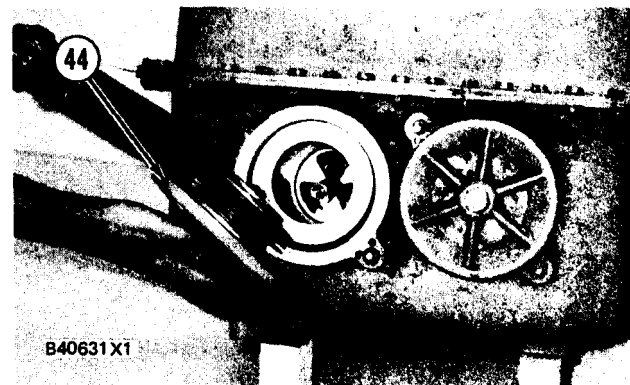

26. Install cover assemblies (44) on the hydraulic tank.
end by:
a) install hydraulic tank

TRANSMISSION NEUTRALIZER GROUP

Models 950BNS and 950BS

**REMOVE TRANSMISSION
NEUTRALIZER GROUP**

3181-11

start by:

- a) remove seat (SEE OPERATOR'S STATION, DISASSEMBLY AND ASSEMBLY)

1. Remove the floor panel that is under the seat.
2. Put identification on wire assemblies (2) for correct installation. Disconnect wire assemblies (2) from the motor.
3. Disconnect hose assembly (4) from the motor.
4. Remove bolts (3) and remove lower floor plate (1) from the machine.
5. Remove tube assembly (8) from the neutralizer group.
6. Disconnect wire assembly (5) from the neutralizer group.
7. Remove screws (7) and plate (6) from the neutralizer group.
8. Remove bolts (9) that hold the neutralizer group to the transmission.
9. Disconnect lever (11) from valve spool (10).
10. Remove lever (11) from cam (13).
11. Remove cam (13) from cable assembly (14).
12. Remove nut (15) from cable assembly (14) and remove transmission neutralizer group (12).

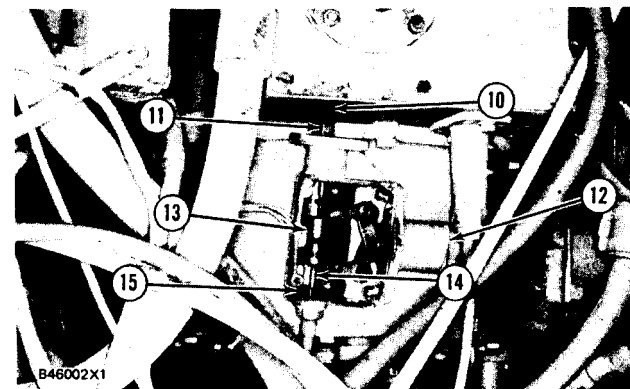
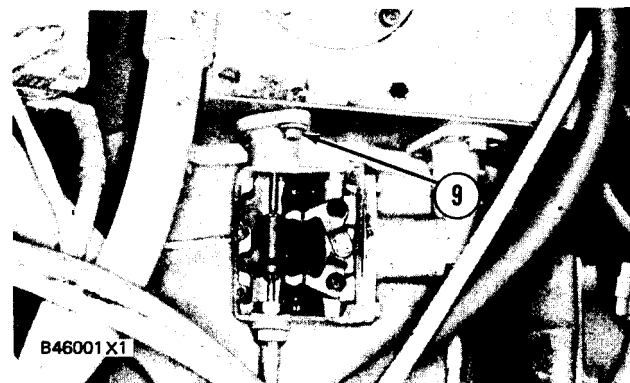
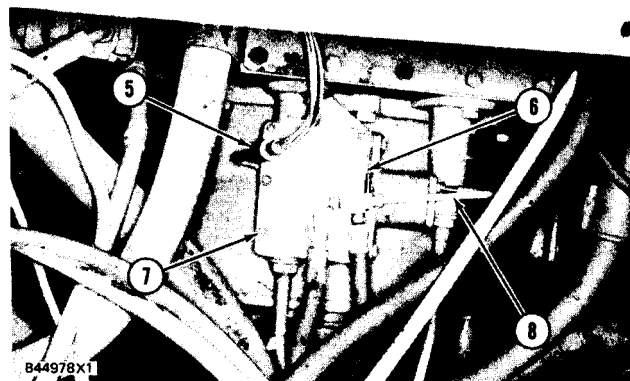
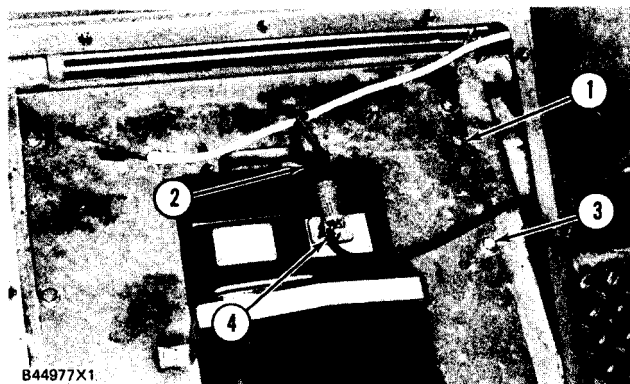

TRANSMISSION NEUTRALIZER GROUP

Models 950BNS and 950BS

INSTALL TRANSMISSION NEUTRALIZER GROUP

3181-12

1. Put cable assembly (6) in position in transmission neutralizer (3) and install nut (5).
2. Install cable assembly (6) on cam (4).
3. Install lever (1) on cam (4),
4. Install lever (1) on valve spool (2).
5. Put transmission neutralizer group (3) and gasket in position on the transmission and install bolts (8).
6. Install plate (9), the gasket and screws (7) on the neutralizer group.
7. Connect wire harness (11) and tube assembly (10) to the neutralizer group.
8. Make an adjustment to the transmission neutralizer control group. See POWER SHIFT TRANSMISSION, TESTING AND ADJUSTING.
9. Install lower floor plate (12) on the machine with the bolts that hold it.
10. Connect wire assemblies (13) and hose assembly (14) to the motor.
11. Install the floor plate under the seat.
end by:
 - a) install seat (SEE OPERATOR'S STATION DISASSEMBLY AND ASSEMBLY)

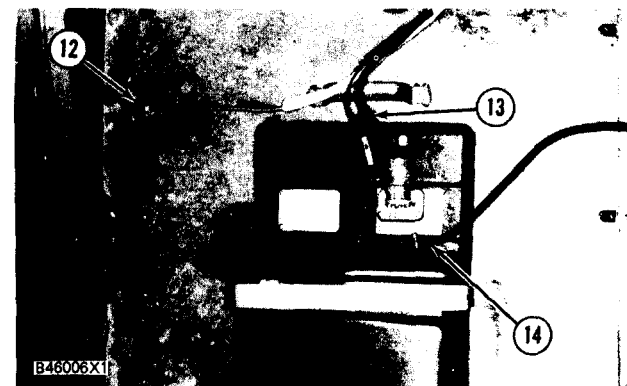
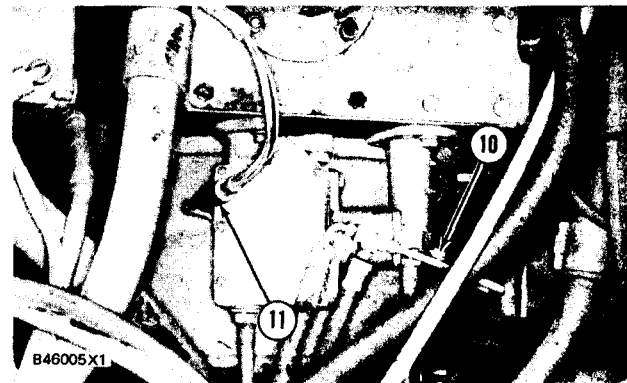
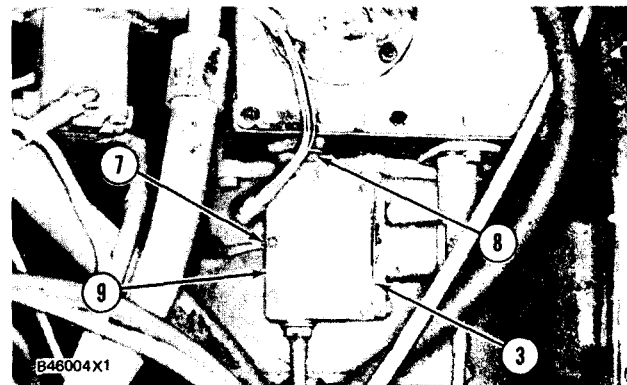
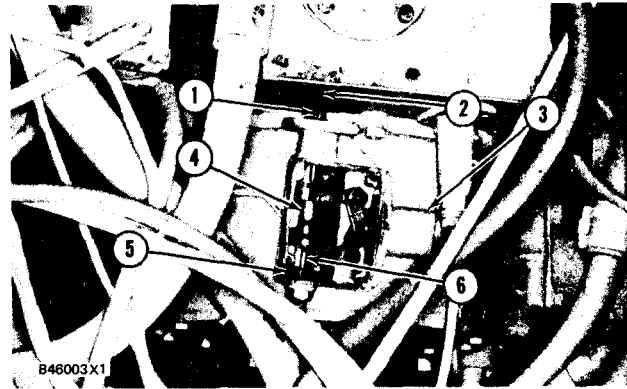

TRANSMISSION NEUTRALIZER GROUP

Models 950BNSCE and 950BSCE

REMOVE TRANSMISSION NEUTRALIZER GROUP 3181-010

1. Remove the seat and the support assembly underneath it. The weight of the seat is approximately 90.7 kg (200 lb.).

NOTE: Step 2 pertains to units with windshield washers.

2. Remove hoses and wire connectors (1). Remove two bolts and washers (2) and the strip around reservoir (3). Remove the reservoir.

3. Remove bolts (5), and remove plate (4).

4. Remove screws (6), and remove plate (7). Remove line (8) from the transmission neutralizer group.

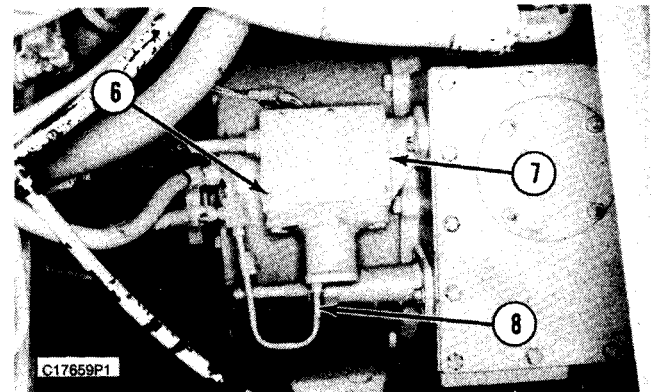
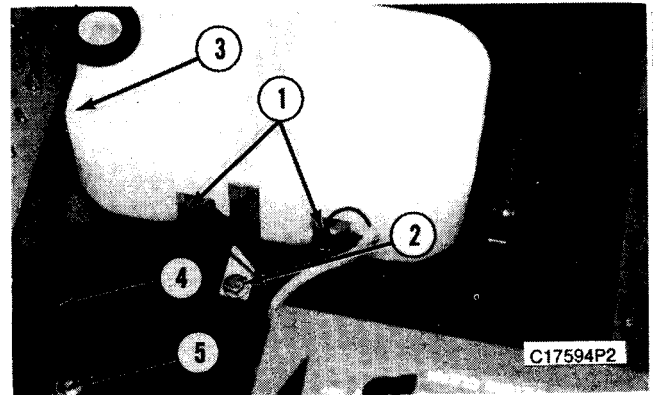

5. Disconnect wire assembly (9) from the transmission neutralizer group.

6. Remove bolts (11) that hold the transmission neutralizer group to the transmission.

7. Disconnect rod end (10) of the transmission neutralizer group from the spool inside the transmission case (16).

8. Remove rod end (13) from cam (15). Remove locknut (14) from rod end (13).

9. Remove nut (12) from the cable assembly, and remove transmission neutralizer group (17).

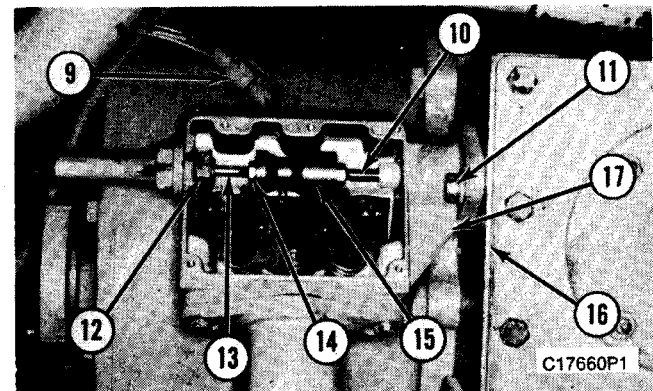

TRANSMISSION NEUTRALIZER GROUP

Models 950BNSCE and 950BSCE

INSTALL TRANSMISSION NEUTRALIZER GROUP

1. Put the cable assemble in position in transmission neutralizer group (17), and install nut (12).
2. Install rod end (13) on cam (15) with locknut (14) in position as shown.
3. For the adjustment procedure to the cam assembly, refer to the Installation Group-Controls in the Testing And Adjusting Manual.
4. Tighten locknut (14) to a torque of 8 ± 5 N.m (6 ± 4 lb. ft.).
5. Connect rod end (10) of the transmission neutralizer group to the spool inside the transmission case (16).
6. Install bolts (11) that hold the transmission neutralizer group to the transmission.
7. Connect wire assembly (9) to the transmission neutralizer group.
8. Install line (8) to the transmission neutralizer group. Install plate (7) with the gasket, and install screws (6).

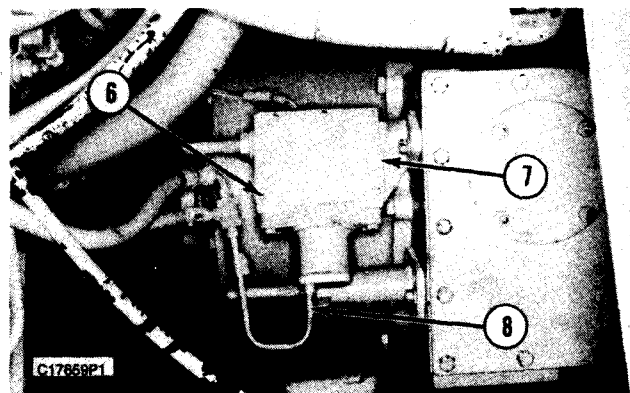
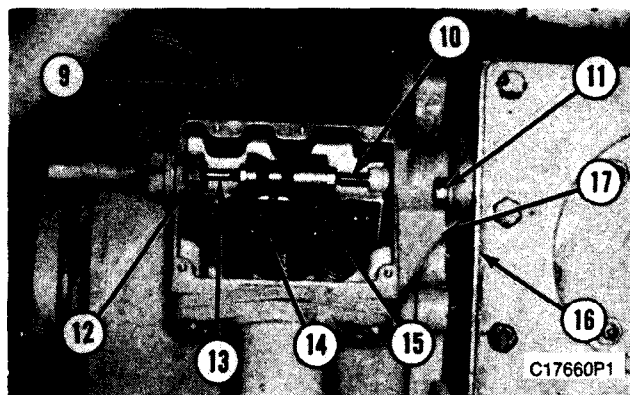

9. Install plate (4) and bolts (5). Position reservoir (3), and the strip around the reservoir with bolts and washers (2). Install hoses and wire connectors (1).

10. Install the support assembly and the seat.

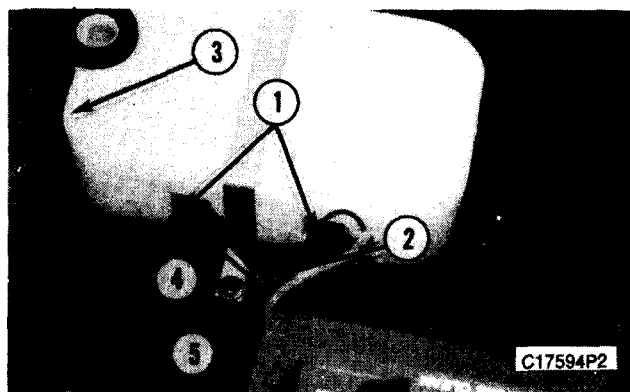

TRANSMISSION NEUTRALIZER GROUP

DISASSEMBLE TRANSMISSION NEUTRALIZER GROUP

3181-15

start by:

a) remove transmission neutralizer group

1. Remove housing assembly (2) and plate (1) from the transmission neutralizer group housing.

NOTE: On models 950BNSCE and 950BSCE, there is an O-ring on each side of plate (1).

2. Remove piston (4) from the housing assembly.

3. Remove seal (3) from the piston.

4. Remove bolts (7) and spacers. Remove spring (5) and lever assembly (6).

5. Remove retainer ring (9) from pin (10). Make a separation of levers (8).

6. Loosen nut (11). Remove cam (12) from the rod.

7. Remove rod (13) from the housing.

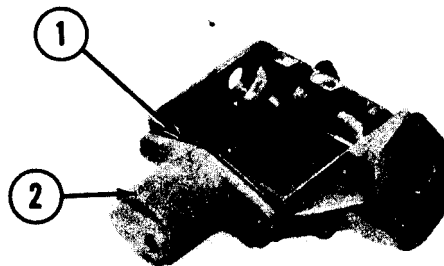

B31488X1

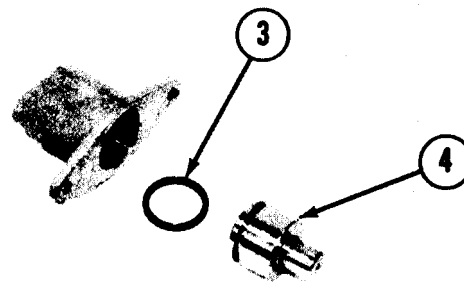

B31490X1

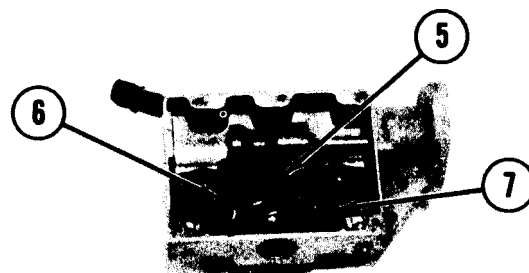

B31492X1

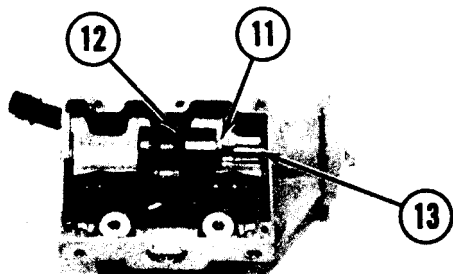

B31496X1

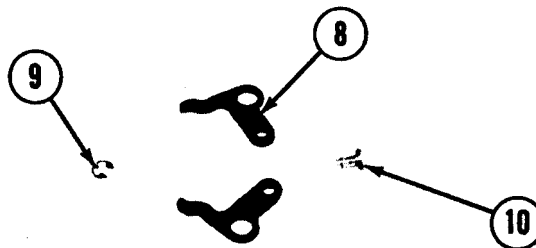

B31493X1

TRANSMISSION NEUTRALIZER GROUP

8. Remove two screws (14) from each switch. Remove wiring harness (15) and switches from the housing as a unit.

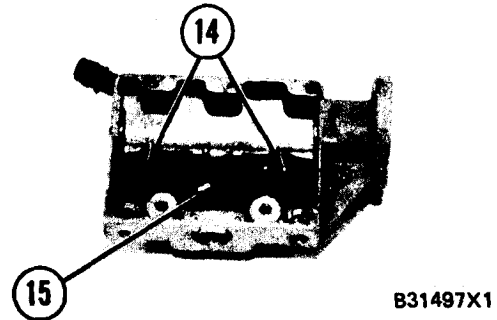

9. Disconnect wires (17) and (18) from the switches. Put identification on the wires so they will not be mixed at assembly.

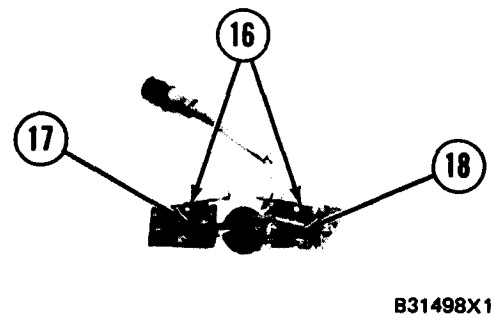

10. Remove switches (16).

ASSEMBLE TRANSMISSION NEUTRALIZER GROUP

3181-16

1. Put switches (1) and (3) in position on the wiring harness. Connect wires (2) and (4) to the switches. Make sure the wires are installed in their original position.

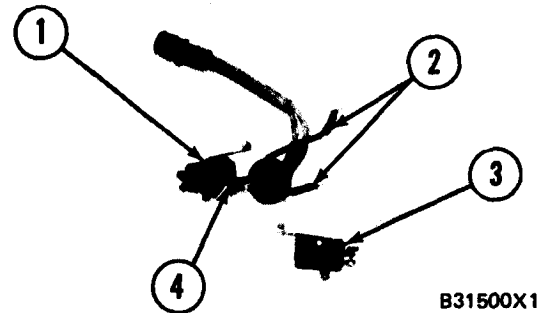

NOTE: Remove the screw from the switch terminal that is not used.

2. Install switches and wiring harness (5) in housing (6). Tighten the screws and nuts to a torque of $0.5 \pm 0.1 \text{ N}\cdot\text{m}$ ($5 \pm 1 \text{ lb.in.}$).

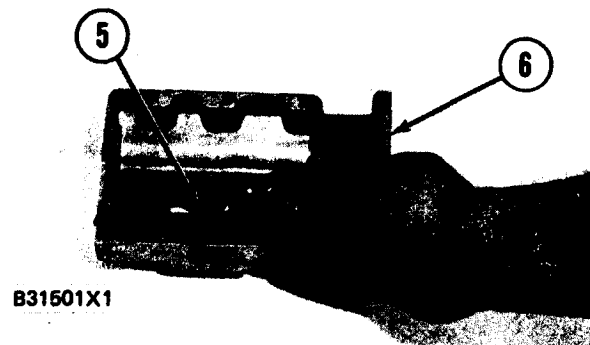

TRANSMISSION NEUTRALIZER GROUP

3. Apply Loctite to nut (8). Install rod (9) and nut (8) in cam (7).
4. Install the cam assembly into the housing.
For the adjustment procedure to the cam assembly, see POWER SHIFT TRANSMISSION TESTING AND ADJUSTING, Volume 1 of Maintenance Manual. Tighten nut (8) to 8 ± 5 N-m (6 ± 4 lb.ft).
5. Put 1P808 General Purpose Lubricant on the pin. Install pin (12) in levers (11). Install retainer ring (10) on the pin.

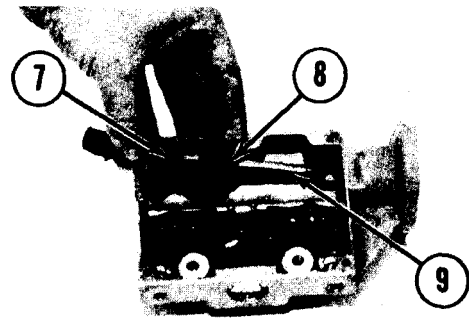

B31503X1

6. Install spring (13) on the lever assembly.

7. Put lever assembly (14) in position in the housing. Put 1P808 General Purpose Lubricant on the spacers and install spacers (15) and bolts that hold the lever assembly.

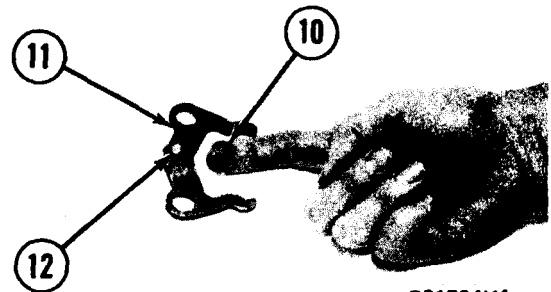

B31504X1

8. Put 1P808 General Purpose Lubricant in the bore of housing assembly (17).

NOTE: Upon installation of seal (18) to the piston, the seal should not be rolled or twisted in the groove in piston (16). This will cause excessive drag and seal failure.

9. Install seal (18) on the piston.
10. Install piston (16) in the housing assembly.
11. Install plate (19) and housing assembly on the housing.
end by:
a) install transmission neutralizer group

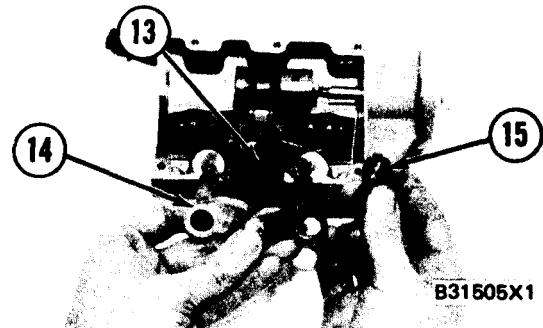

B31505X1

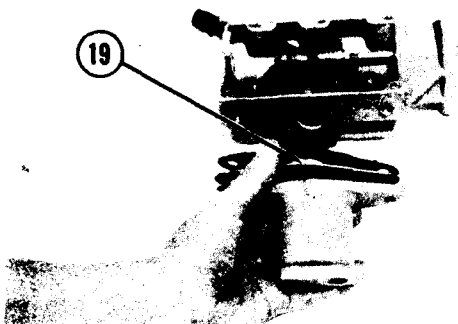

B31507X1

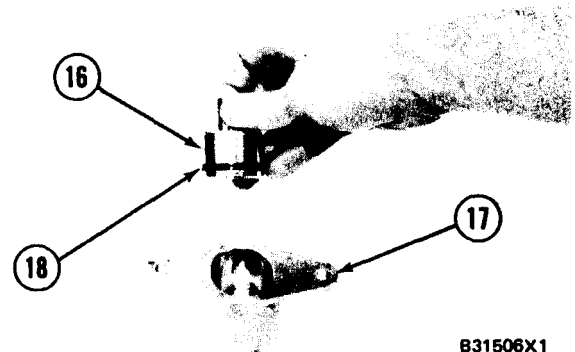

B31506X1

AIR RESERVOIR

REMOVE AND INSTALL AIR RESERVOIR

4272-11

Tools Needed	A
OTC Model 1790 Transmission Jack 1	

1. Turn the valve on the bottom of the reservoir to the "OPEN" position and release the air pressure from the reservoir.
2. Put tool (A) in position under guard (2).
3. Remove bolts (1) and guard (2) from the machine. The weight of the guard is 32 kg (70 lb.).
4. Disconnect air lines (6) and (4) from air reservoir (5).
5. Remove bolts (3), clamps (7) and air reservoir (5) from the machine.
6. Put air reservoir (7) in position on the machine and install clamps (5) and bolts (4) that hold it.
7. Turn the valve on the bottom of the reservoir to the "CLOSED" position. Connect lines (3) and (6).
8. Use tool (A) and install guard (2) on the machine.

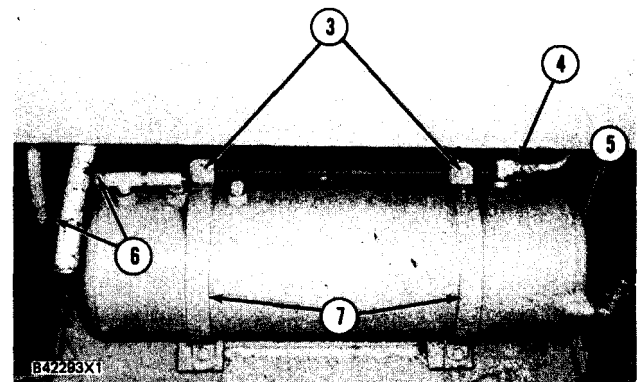
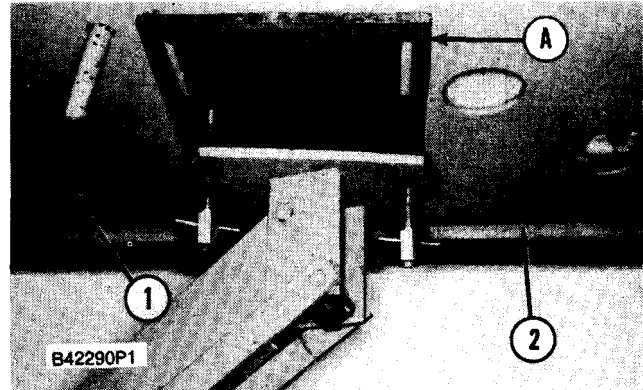

Models 950BNS and 950BS

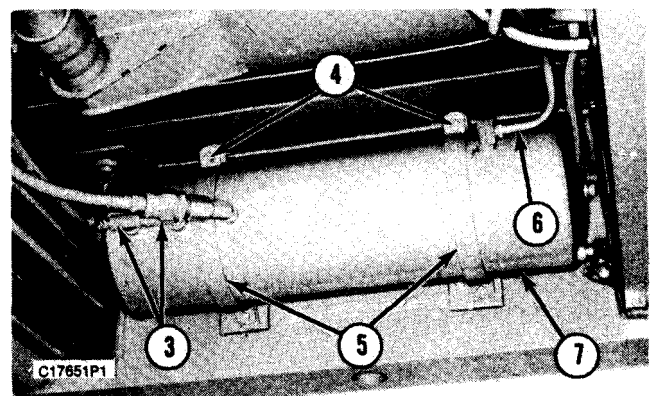

Models 950BNSCE and 950BSCE

AIR DRYER

WARNING

If NBC exposure is suspected, all air filter media should be handled by personnel wearing protective equipment. Consult your unit NBC Officer or NBC NCO for appropriate handling or disposal instructions.

REMOVE AND INSTALL AIR DRYER

1. Disconnect inlet hose (1) from air dryer (2).
2. Disconnect outlet hose (3).
3. Disconnect unloader hose (4).
4. Unscrew heater element (5) from bottom of air dryer (2).
5. Loosen four nuts (6) enough to allow dryer (2) to be removed.
6. Position air dryer in clamps (7).
7. Screw heater element (5) into bottom of air dryer (2).
8. Connect unloader hose (4).
9. Connect outlet hose (3).
10. Connect inlet hose (1).

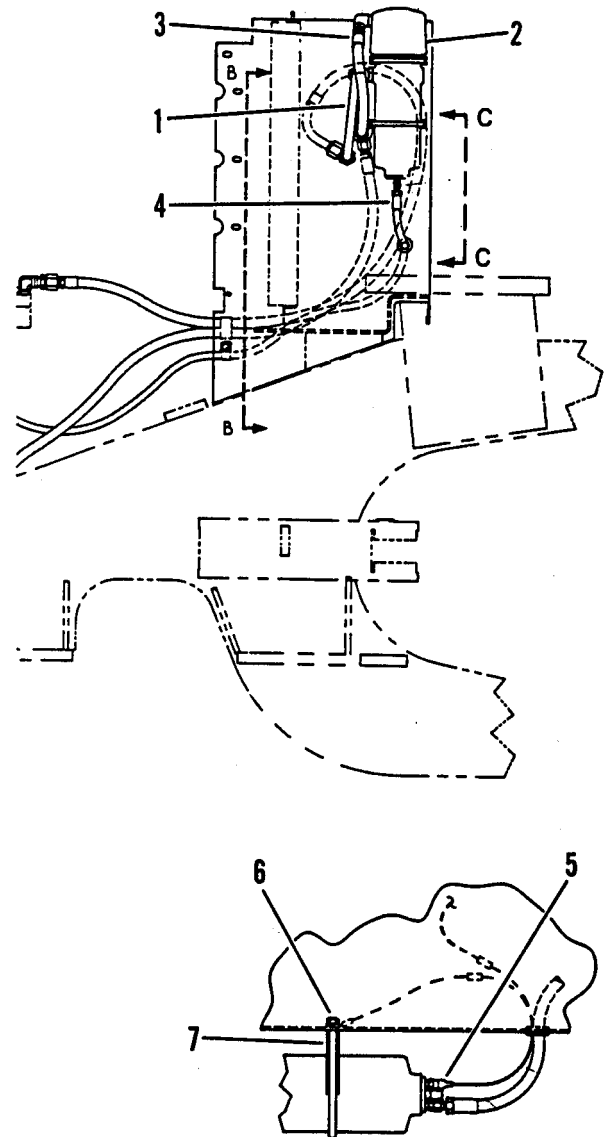

VIEW C-C

VEHICLE SYSTEMS

DISASSEMBLE AIR DRYER

1. Remove two nuts (1) and washer (2) from the air dryer.
2. Pull cap (3) off with a twisting upward motion. Remove cover seal (4).
3. Unscrew center shaft (5). Shaft (5) is spring loaded and will release as the shaft is unthreaded.
4. Remove shaft (5) and two sealing washers (6) from purge plate (7).
5. Lift purge plate (7) and spring (8) off of desiccant canister (9).
6. Remove sealing rings (10) and (11) from purge plate (7).
7. Remove desiccant canister (9), It may be necessary to loosen canister (9) with a screwdriver by prying upward (screwdriver inserted in canister prying groove).
8. Remove canister sealing ring (12).
9. With desiccant canister (9) upright, remove tube retaining ring (13) with a-screwdriver.

WARNING

If NBC exposure is suspected, all air filter media should be handled by personnel wearing protective equipment. Consult your unit NBC Officer or NBC NCO for appropriate handling or disposal instructions.

10. Remove filter screen (14) and cloth filter pad (15).

NOTE: Filter pad is attached to filter screen.

11. Tip the canister (9) over and pour out the desiccant (16).
12. Invert canister (6) and remove retaining ring (17) which holds the deflector plate (18).
13. Remove oil separator pad (19).

DISASSEMBLY AND ASSEMBLY

14. Remove retaining ring (20) and remove lower filter pad (21), retainer screen (22), and tube (23),
15. Unscrew port plug (24) from dryer body (25).
16. Unscrew tube (26) and then unscrew spring seat (27).

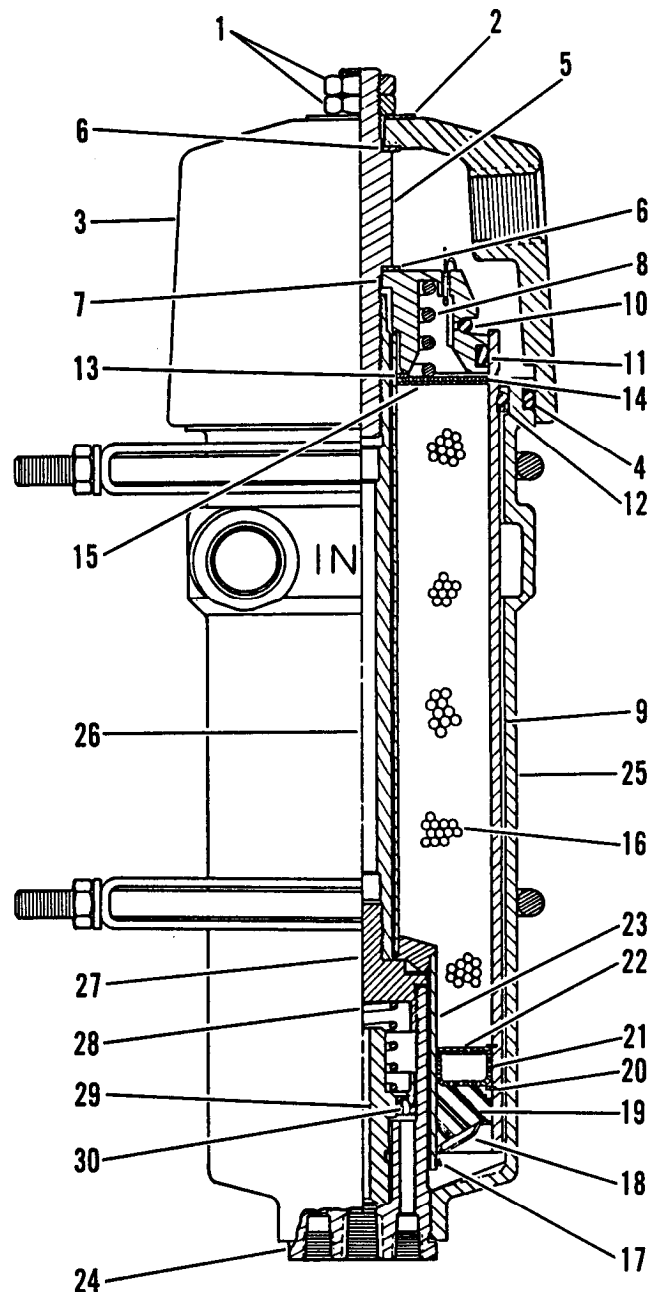

VEHICLE SYSTEMS

17. Remove unloader valve spring (28) and unloader valve (29).
18. Remove U-cup (30).

WARNING

If NBC exposure is suspected, all air filter media should be handled by personnel wearing protective equipment. Consult your unit NBC Officer or NBC NCO for appropriate handling or disposal instructions.

ASSEMBLE AIR DRYER

1. Install U-cup (30), unloader valve (29), and valve spring (28) in port plug (24).
2. Screw spring seat (27) into port plug (24).
3. Screw tube (26) onto spring seat (27).
4. Screw port plug (24) into dryer body (25).
5. Install tube (23), lower filter pad (22), retainer screen (21) and retaining ring (20).

NOTE: Both the upper and lower filter pads must completely cover their respective retainer screens to prevent the desiccant from rubbing against the rough screen surfaces.

6. Install oil separator pad (19), deflector plate (18), and retaining ring (17).
7. Pour desiccant (16) into canister (9). Shake and tamp down the desiccant, Desiccant level should be filled to retaining ring (13) groove.
8. Install cloth filter pad (15) and filter screen (14).
9. Push screen (14) down until retaining ring (13) can be installed.
10. Install canister sealing ring (12).
11. Push canister (9) into dryer body (25).
12. Install sealing rings (11) and (10) on purge plate (7).

DISASSEMBLY AND ASSEMBLY

13. Install spring (8) and purge plate (7).
14. Install sealing washers (6) and shaft (5).
15. Install cover seal (4) and cap (3).
16. Install washer (2) and two nuts (1).

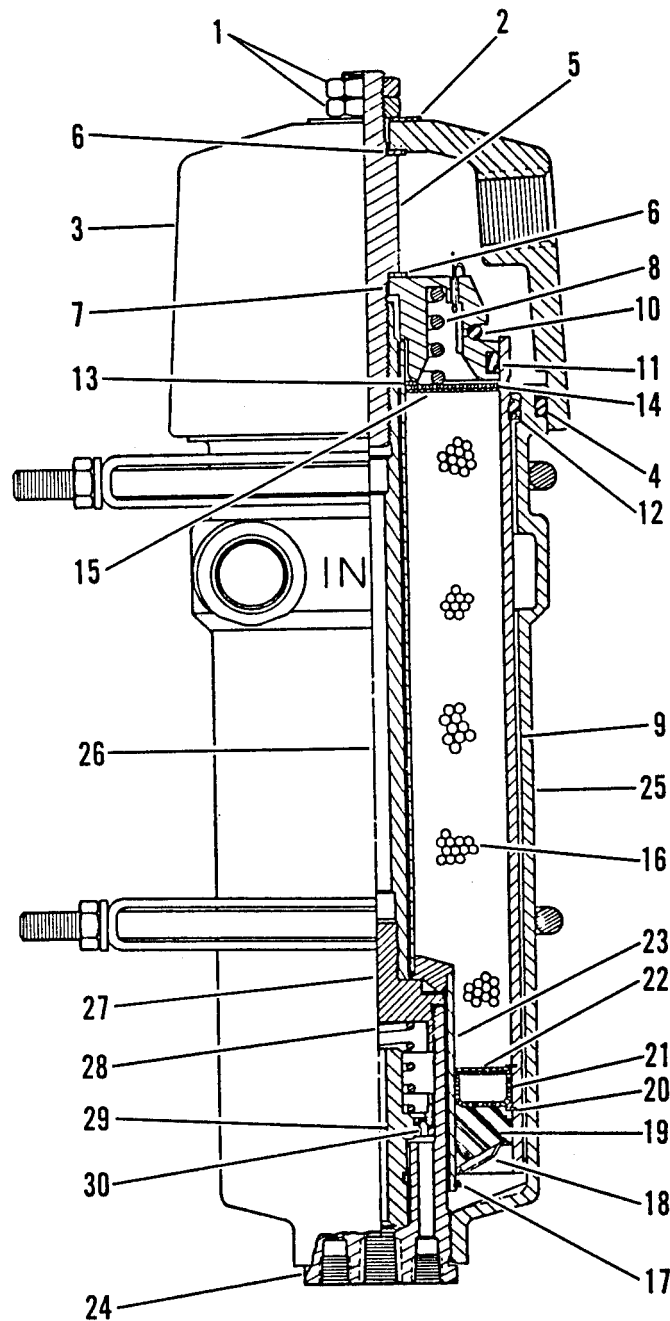

FOOT-OPERATED BRAKE VALVES

REMOVE FOOT-OPERATED BRAKE VALVES

4265-11

start by:

- a) remove brake pedal*

*This operation is in the OPERATOR'S STATION, DISASSEMBLY AND ASSEMBLY section.

WARNING

To prevent personal injury release the pressure from the air reservoir before any lines are disconnected.

1. Remove the bolts and remove shroud (1) from the bottom of the cab.
2. Disconnect hose assembly (2) and wires (3) from the brake valve.
3. Disconnect hose assemblies (4), (5), (6) and (7) from the brake valve.
4. Disconnect tube assembly (8) and remove brake valve (9).

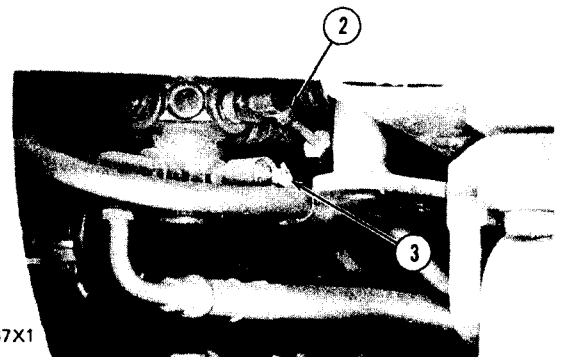
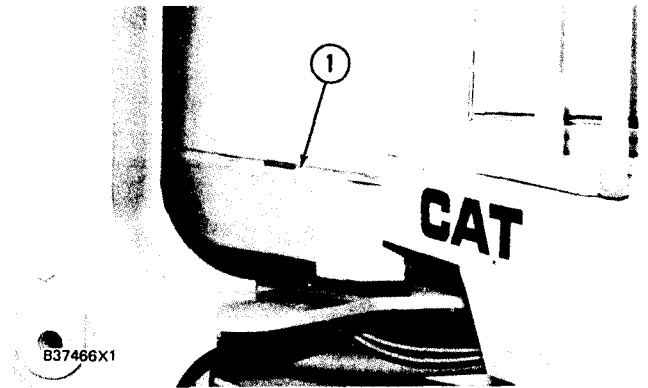

INSTALL FOOT-OPERATED BRAKE VALVES

4265-12

1. Put brake valve (6) in position and connect tube assembly (5) to the brake valve.
2. Connect hose assemblies (1),(2),(3) and (4) to the brake valve.
3. Connect wires (8), hose (7) to the brake valve.
4. Install the shroud to bottom of the cab.
end by:

- a) install brake pedal

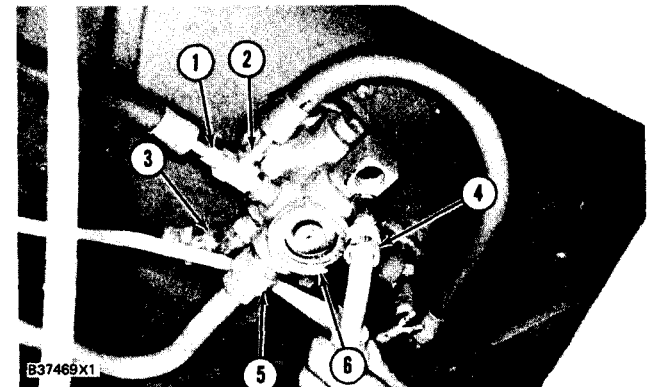
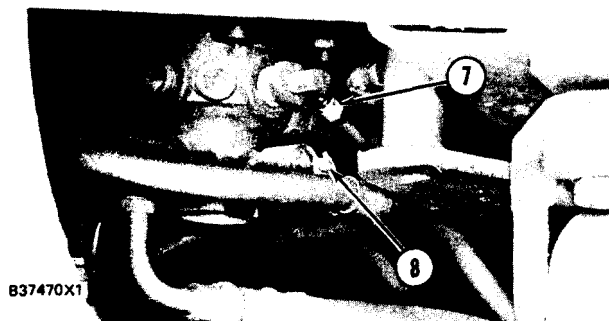
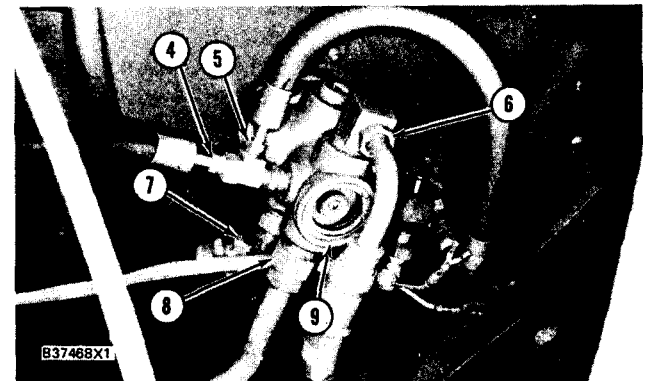

FOOT-OPERATED BRAKE VALVES

DISASSEMBLE FOOT-OPERATED BRAKE VALVE 4265-15

Tools Needed		A
1P1861	Pliers	1

start by:

- a) remove foot operated brake valve

WARNING

Retainer (3) holds spring (1) under compression. To prevent personal injury carefully remove the retainer.

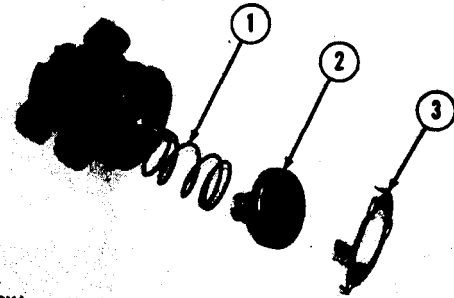

A88358X1

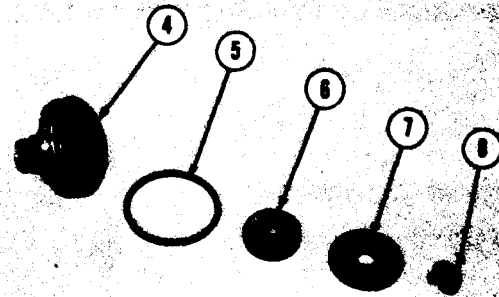

A88359X1

1. Remove retainer (3), piston assembly (2) and spring (1) from the valve body.

2. Remove O-ring seal (5) from the piston.

3. Remove bolt (8) and washer. Remove seat (7) and spring (6) from the piston (4).

4. Use tool (A) to remove snap ring (9) and the washer.

5. Remove valve assembly (10) from the valve body. Remove the O-ring seal from the valve body.

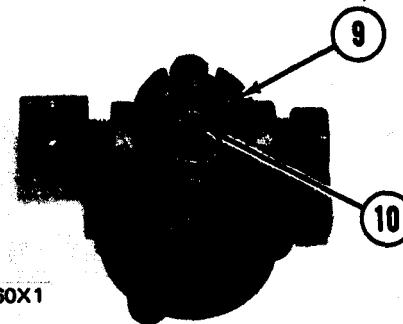

A88360X1

6. Remove screw (18) and washer, diaphragm (17) and spring (16) from seat (15).

7. Remove valve (11) and spring (14) from the seat.

8. Remove O-ring seal (13) and retainer (12) from the valve.

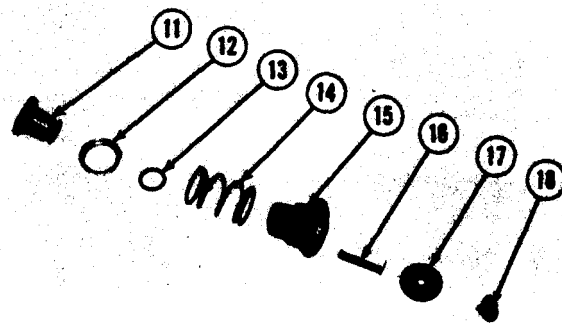

A88361X1

FOOT-OPERATED BRAKE VALVES

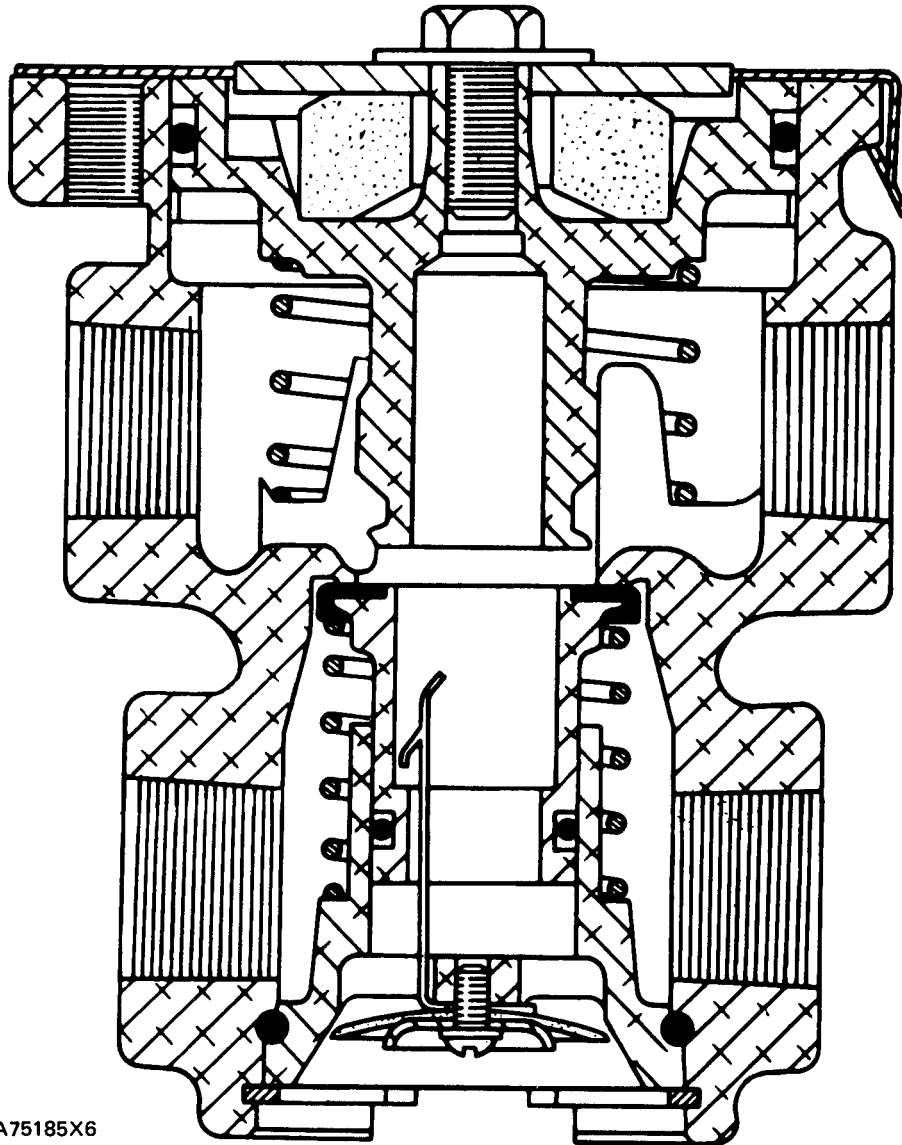

A75185X6

FOOT-OPERATED BRAKE VALVES

ASSEMBLE FOOT-OPERATED BRAKE VALVE 4265-16

	Tools Needed	A
1P1861	Pliers	1

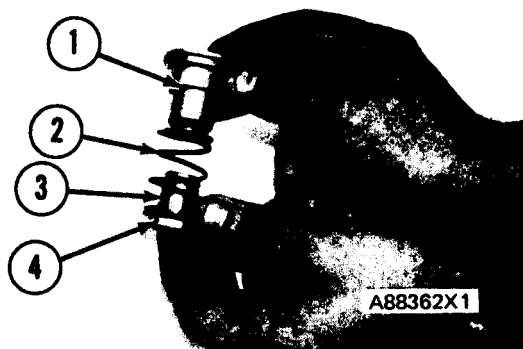

1. Install O-ring seal, retainer (4) and spring (2) on valve (3).

2. Put seat (1) in position on the valve. Install the spring, diaphragm, washer and bolt in the seat.

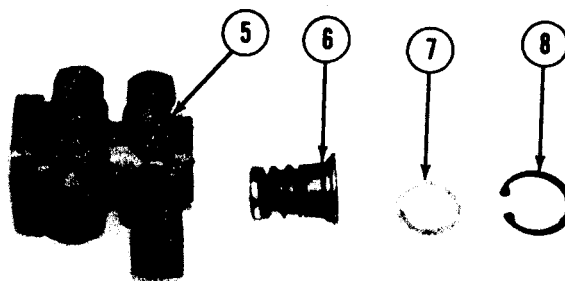

A88363X1

3. Install the O-ring seal in the valve body.

4. Install valve assembly (6), washer (7) and snap ring (8) in valve body (5). Use tool (A) to install the snap ring.

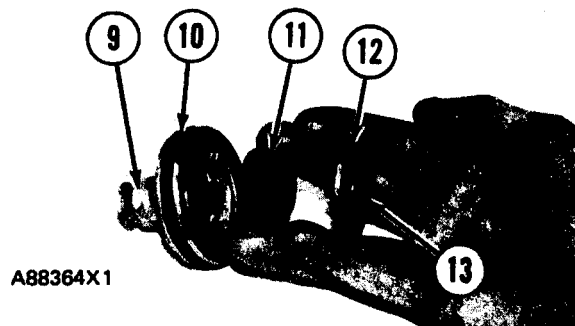

A88364X1

5. Install O-ring seal (10), spring (11), seat (12) and washer and bolt (13) in piston (9).

6. Install spring (14), piston assembly (15) and retainer (16) in the valve body.
end by:
a) install foot-operated brake valve

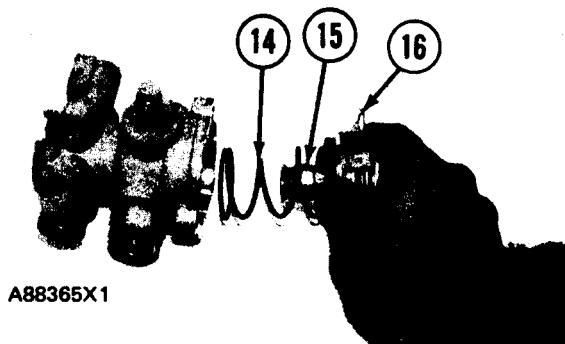

A88365X1

HAND METERING PUMP

REMOVE HAND METERING PUMP 4312-11

start by:

a) connection of anti-pivot link

1. Remove the bolts and shroud (1) from the bottom of the cab.
2. Put identification on lines (2) for assembly purposes.
3. Disconnect lines (2) from hand metering pump (3).
4. Loosen bolts (4) and remove hand metering pump (3).

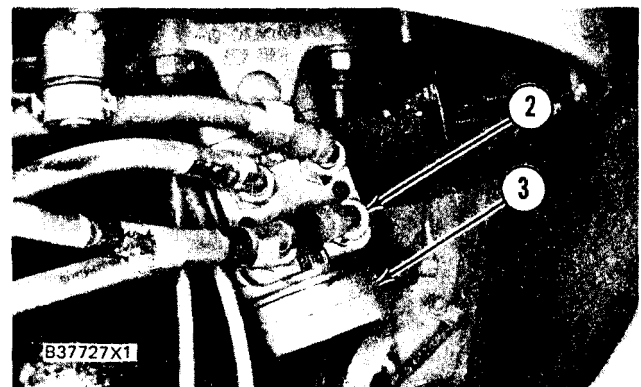
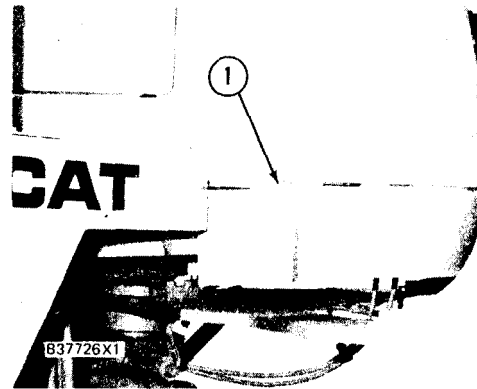

INSTALL HAND METERING PUMP 4312-12

1. Put hand metering pump (1) in position. Make an alignment of the splines on the shaft and the splines in the pump.
2. Connect lines (2) to the hand metering pump.
3. Install the shroud on the bottom of the cab.
end by:
a) separation of anti-pivot link

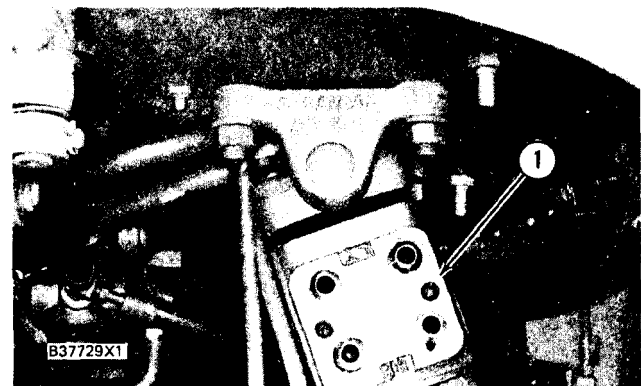
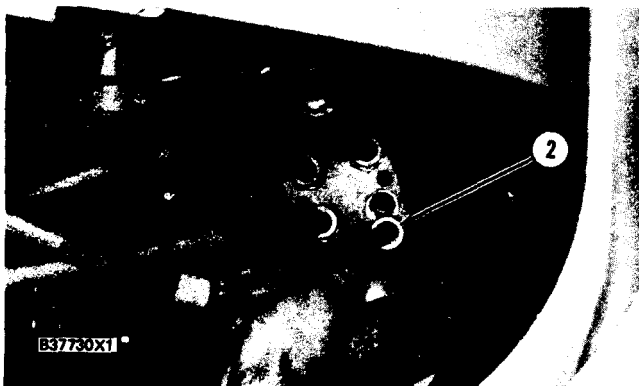
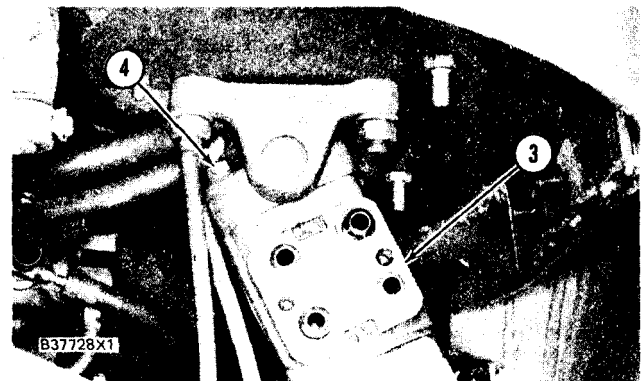

HAND METERING PUMP

DISASSEMBLE HAND METERING PUMP

4312-15

start by:

a) remove hand metering pump

1. Remove bolts (1). Remove cap (2) from the pump body. Remove the O-ring seal from the cap.

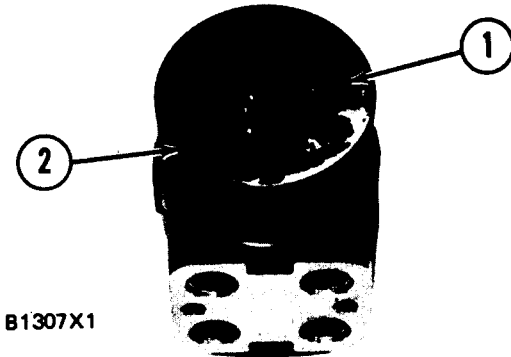

2. Remove gerotor assembly (3) and spacer (4) from the pump body. Remove the O-ring seal from the gerotor assembly.

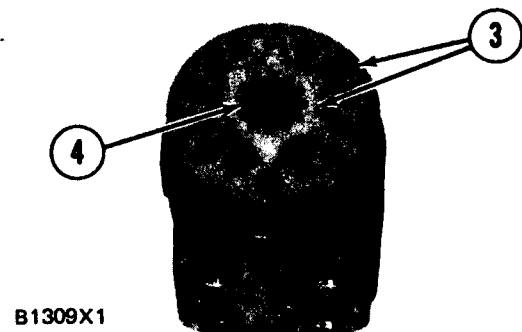

3. Remove drive (5). Remove spacer (6) from the pump body.

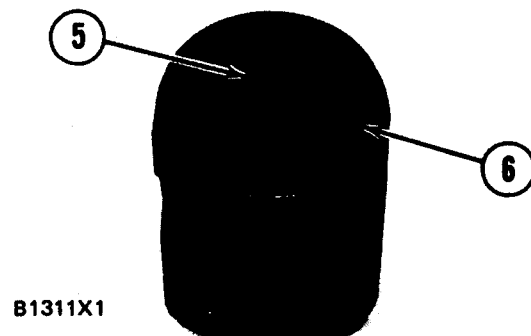

4. Remove O-ring seal (7).

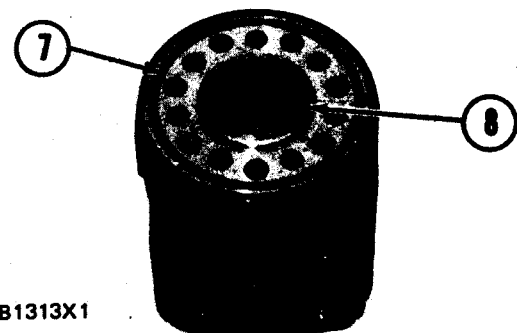

5. Remove sleeve (8) from the pump body.

HAND METERING PUMP

6. Remove pin (11). Remove spool (9) from sleeve (8). Remove six springs (10) from spool (9).

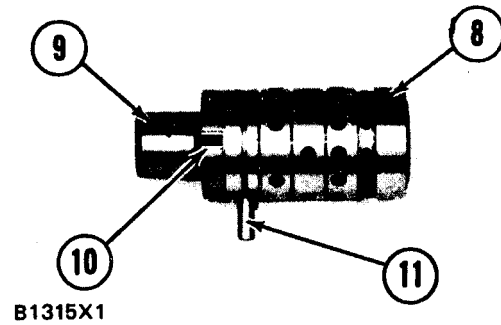

7. Remove bearing races (12) and bearing (13) from the pump body.

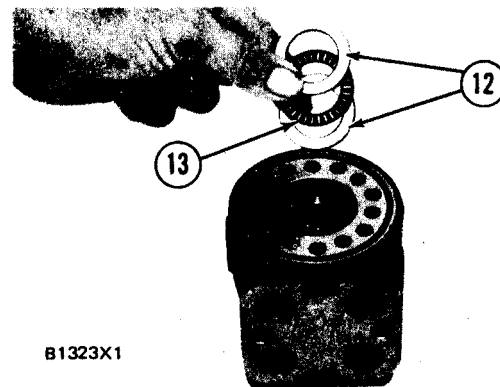

8. Turn the pump body over. Remove spiral locking (14). Remove bushing (15).

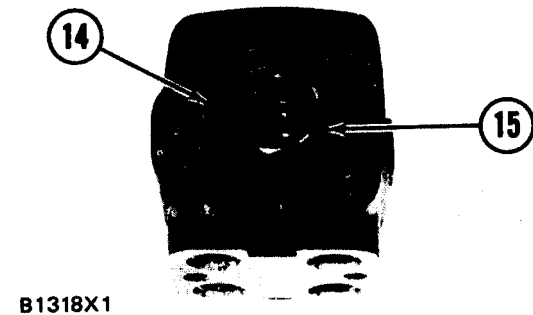

9. Remove seals (16) from bushing (15).

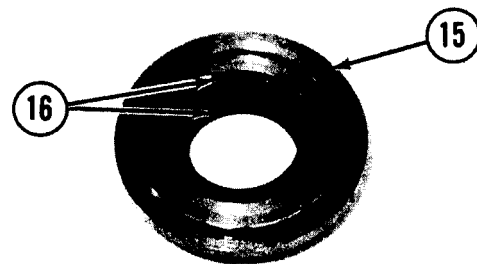

10. Remove plug (17), seat (19), ball (21) and retainer (22) from the pump body. Remove O-ring seals (18) and (20) from the seat.

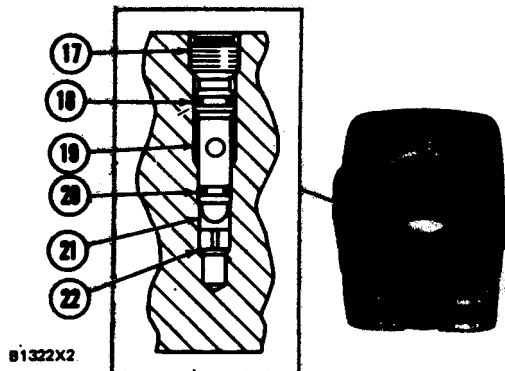

HAND METERING PUMP

ASSEMBLE HAND METERING PUMP 4312-16

1. Make sure all of the parts of the hand metering pump are clean and free of dirt and foreign material. Put clean SAE 10 oil on all parts at assembly.

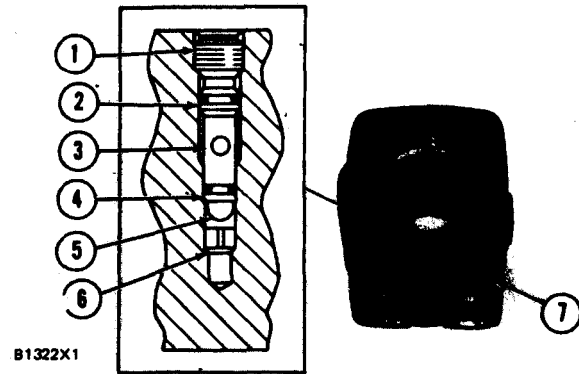

2. Install O-ring seals (2) and (4) on seat (3). Install retainer (6), ball (5), seat (3) and plug (1) in pump body (7). Tighten the plug to a torque of 11 N.m (8 lb. ft.). Make sure the plug is even with or below the pump body surface after it is tightened.

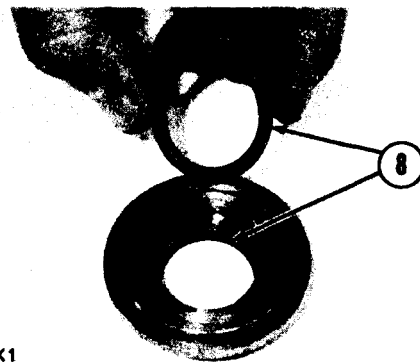

3. Install seals (8) in the bushing.

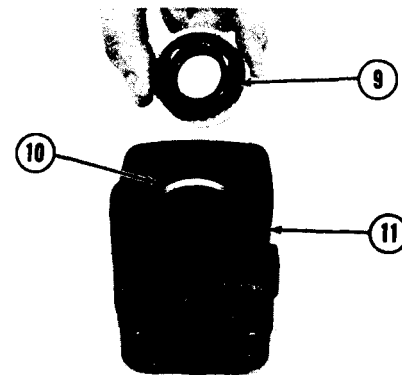

4. Install O-ring seal (10) in pump body (11). Put bushing (9) in position in pump body (11). Install the spiral lockring that holds it.

5. Turn the pump body over. Install O-ring seal (14) on the pump body.

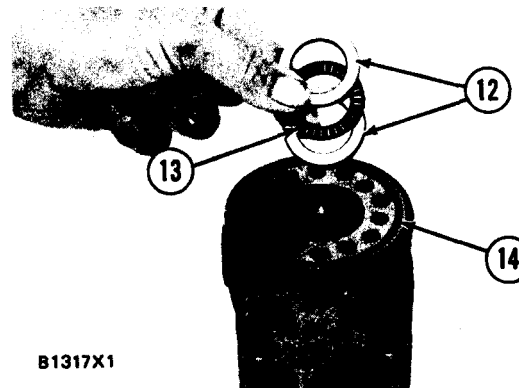

6. Install bearing races (12) and bearing (13) in the pump body.

HAND METERING PUMP

7. Install six springs (17) in spool (15) with three springs on each side. Make sure the curves of the springs are in contact and in the center of the spool. The notched side of the spring ends must be toward the sleeve.

8. Install sleeve (16) over spool (15) so the notch (slot) in the sleeve engages with the ends of springs (17). Install pin (18) in the sleeve and spool.

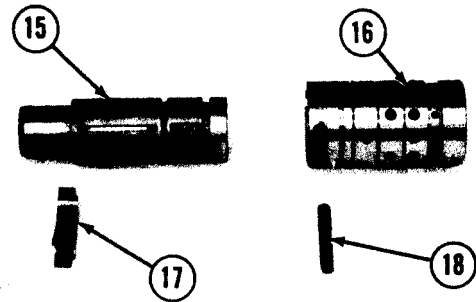

B1316X1

9. Install sleeve assembly (19) in the pump body.

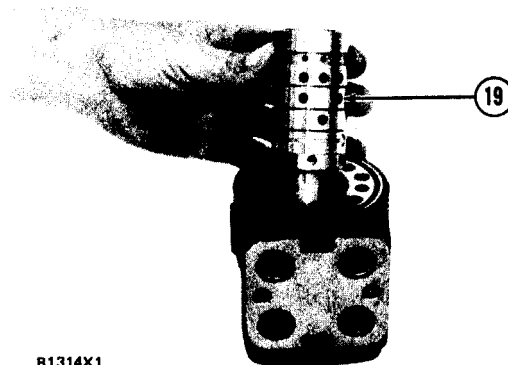

B1314X1

10. Put spacer (21) in position on the pump body.

11. Install drive (20) in the pump body. Make sure the notch (slot) in the drive is engaged with pin (18) that holds the sleeve and spool together.

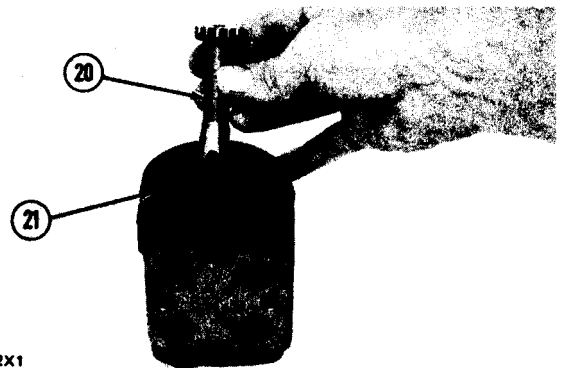

B1312X1

12. Install O-ring seal (23) on gerotor assembly.

13. Install spacer (24) and gerotor assembly (22).

NOTE: Make sure the gear of gerotor assembly (22) is in alignment with pin (18) as shown.

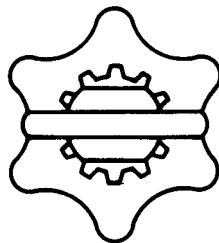

B2276X1

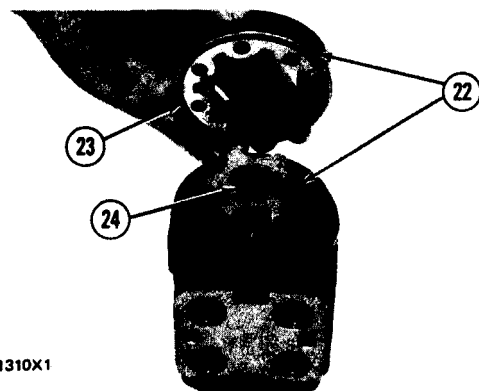

B1310X1

HAND METERING PUMP

14. Install O-ring seal (26) on the cap.

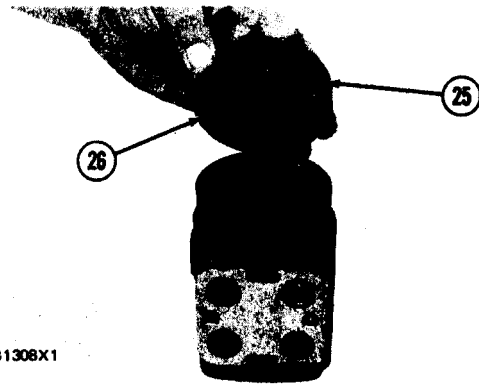

B1308X1

15. Put cap (25) in position on the gerotor assembly.

NOTE: The bolts that hold the cap and gerotor assembly to the pump body must be dry when installed.

16. Install the bolts that hold the cap and gerotor assembly to the pump body. Tighten the bolts as follows:

- a) Tighten the bolts in number sequence to a torque of 14 ± 3 N.m (10 ± 2 lb.ft.).
- b) Tighten the bolts again in number sequence to a torque of 28 ± 3 N.m (21 ± 2 lb. ft). end by:
- a) install hand metering pump

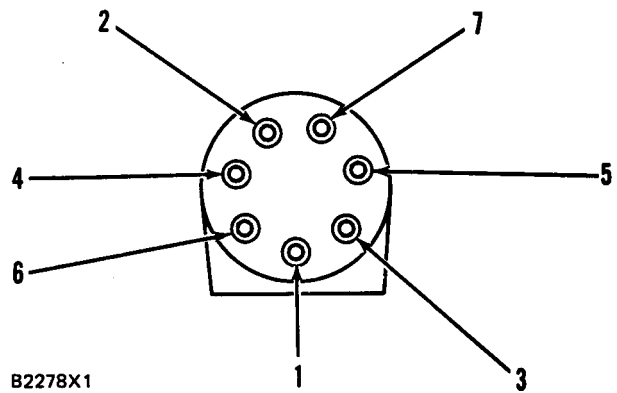

B2278X1

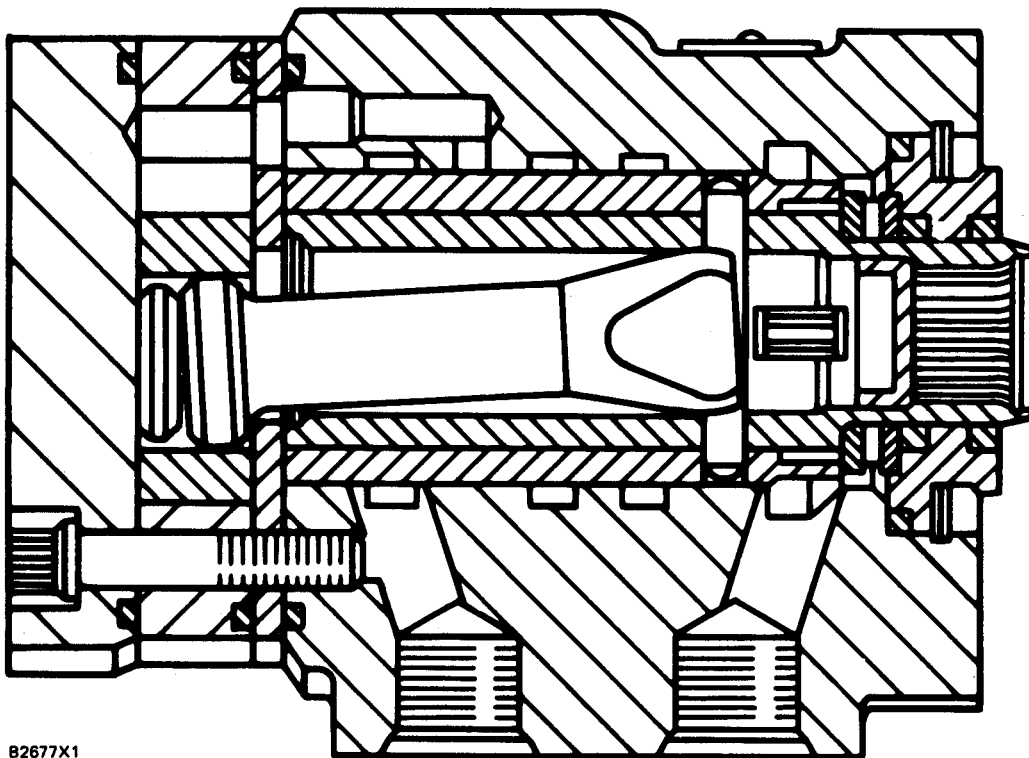

B2677X1

AIR/HYDRAULIC CYLINDER GROUP

REMOVE AIR/HYDRAULIC CYLINDER GROUP

4258 & 4262-11

1. Open access panel (1) behind the cab.

WARNING

To prevent personal injury release the pressure in the air reservoir and hydraulic system before any lines are disconnected.

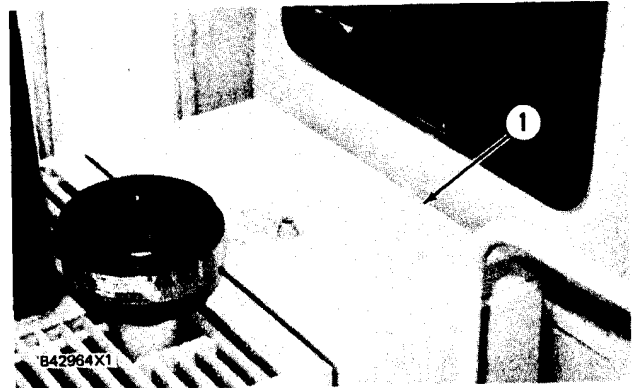

2. Put identification on the wires. Disconnect wires (2) from the air/hydraulic cylinder group.

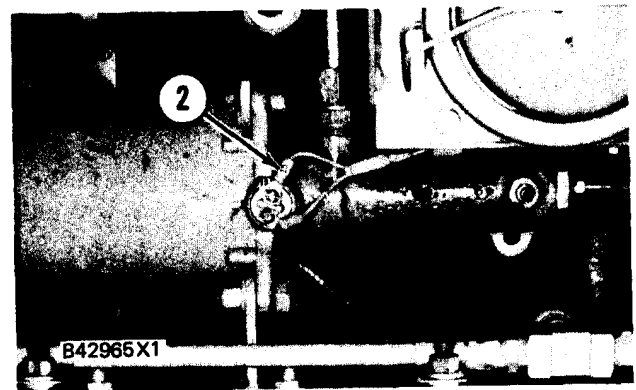

3. Disconnect tube assemblies (3) and (5) from the air/hydraulic cylinder group,

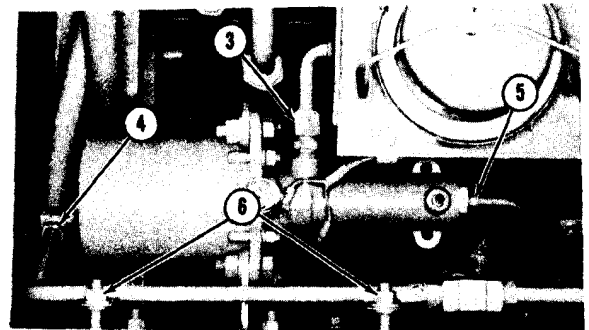

4. Loosen nuts (6) and disconnect tube assembly (4) from the air/hydraulic cylinder group.

B42966X1

5. Remove nuts (8) and bolts (9) and remove air/hydraulic cylinder group (7) from the machine.

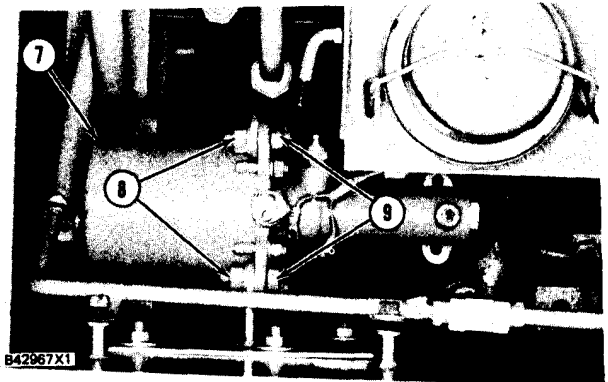

6. Do Steps 2 through 5 to remove the other air/hydraulic cylinder group.

AIR/HYDRAULIC CYLINDER GROUP

INSTALL AIR/HYDRAULIC CYLINDER GROUP

4258 & 4262-12

1. Put air/hydraulic cylinder group (1) in position on the machine and install bolts (2) and the nuts.

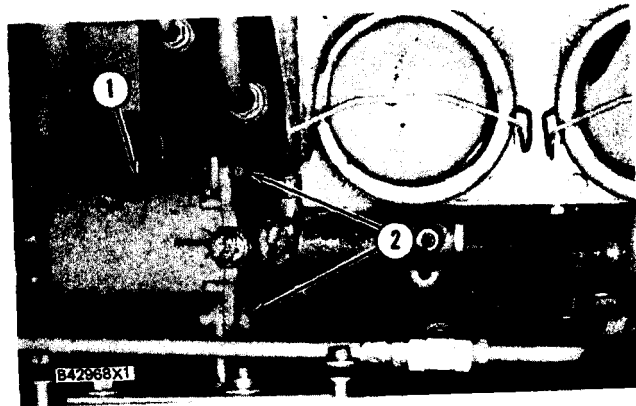

2. Connect tube assemblies (3) and (4) to the air/hydraulic cylinder group.

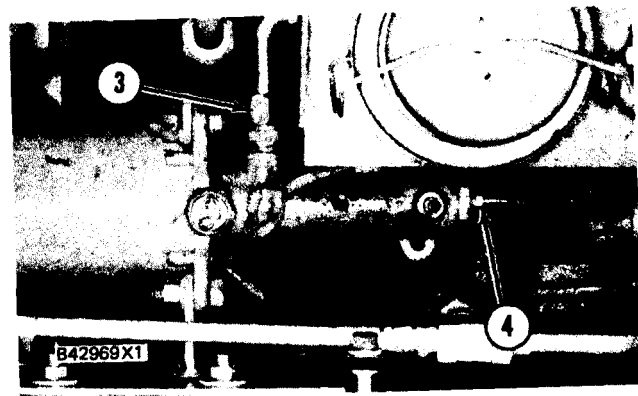

3. Connect tube assembly (6) to the air-hydraulic cylinder and tighten nuts (7).

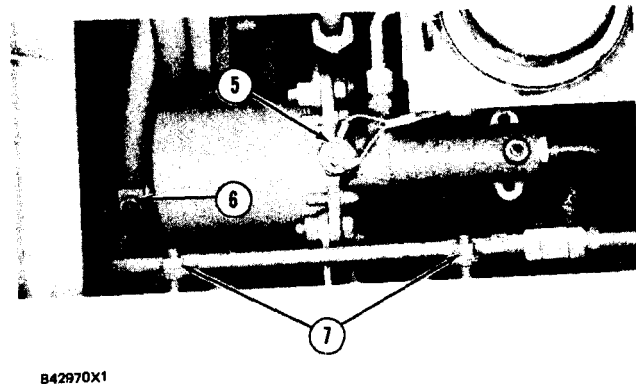

4. Connect wires (5) to the air/hydraulic cylinder group.

5. Do Steps 1 through 4 to install the other air/hydraulic cylinder group.

6. Remove (bleed) the air from the brake system. See SYSTEMS OPERATION, TESTING AND ADJUSTING.

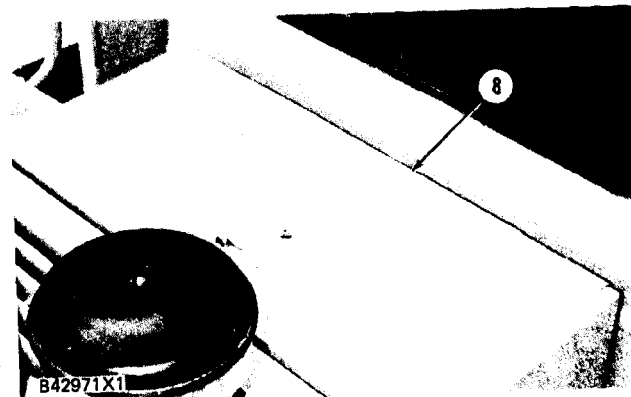

7. Close access panel (8) behind the cab.

AIR/HYDRAULIC CYLINDER GROUP

DISASSEMBLE AIR/HYDRAULIC CYLINDER GROUP 4258 & 4262-15

Tools Needed		A
1P1854	Pliers	1

start by:

a) remove air/hydraulic cylinder group

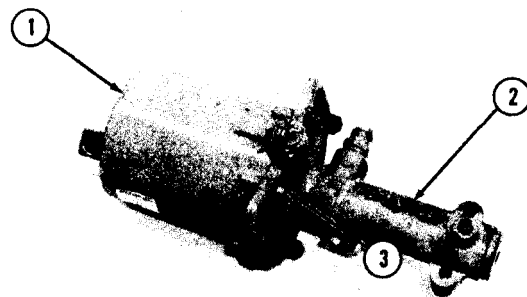

B46007X1

1. Remove nuts (3) and make a separation of cylinder (1) from tube assembly (2).

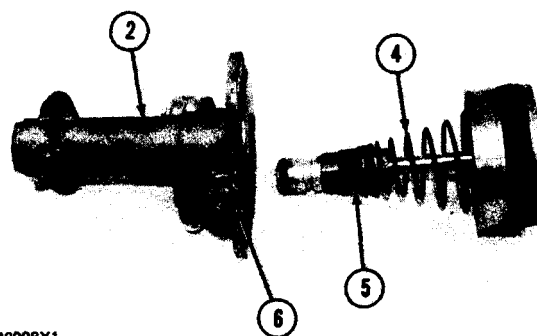

B46008X1

2. Put a small amount of compression on spring (4). Loosen and remove nut (5) from tube assembly (2).

3. Remove switch assembly (6) and the rod indicator from tube assembly (2).

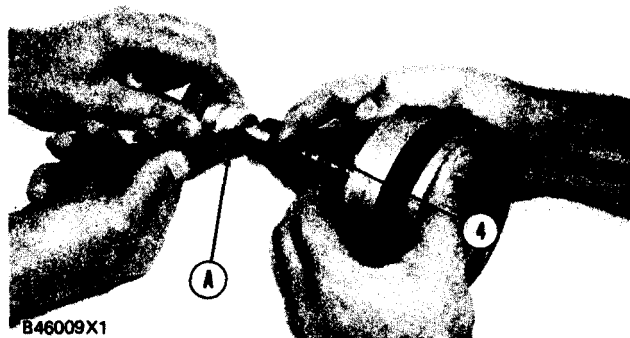

B46009X1

4. Put a small amount of compression on spring (4). Use tool (A) to remove the retaining ring from the shaft.

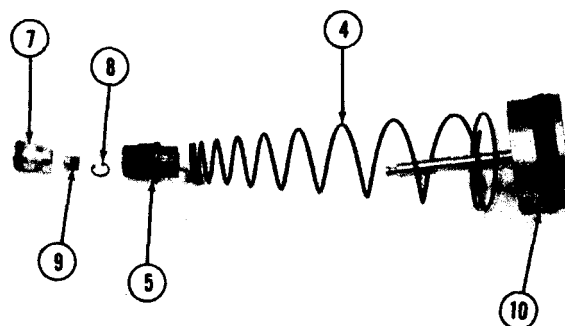

B46010X1

5. Remove piston (7), retainer valve (9), retaining ring (8), nut (5) and spring (4) from piston assembly (10).

AIR/HYDRAULIC CYLINDER GROUP

5. Remove vee seal (11) from piston (7).

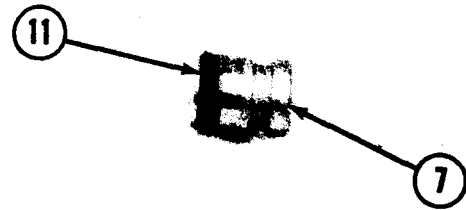

B46011X1

6. Remove seal valve (12) from retainer valve (9).

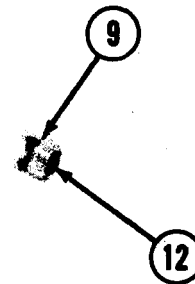

B46012X1

7. Remove vee seals (13) and O-ring seal (14) from nut (5).

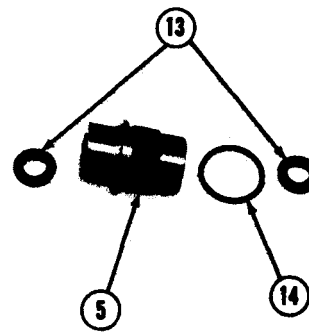

B46013X1

8. Remove nut (15) and the washer from the piston assembly.



B46014X1

9. Remove seal carrier (21) from shaft (19).

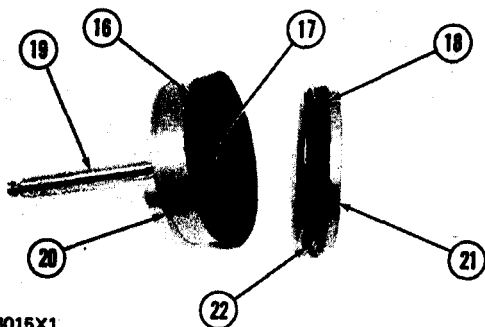

B46015X1

10. Remove spring (22) and felt seal (18) from the seal carrier.

11. Remove piston cup (16) from piston (20).

12. Remove O-ring seal (17) and piston (20) from shaft (19).

AIR/HYDRAULIC CYLINDER GROUP

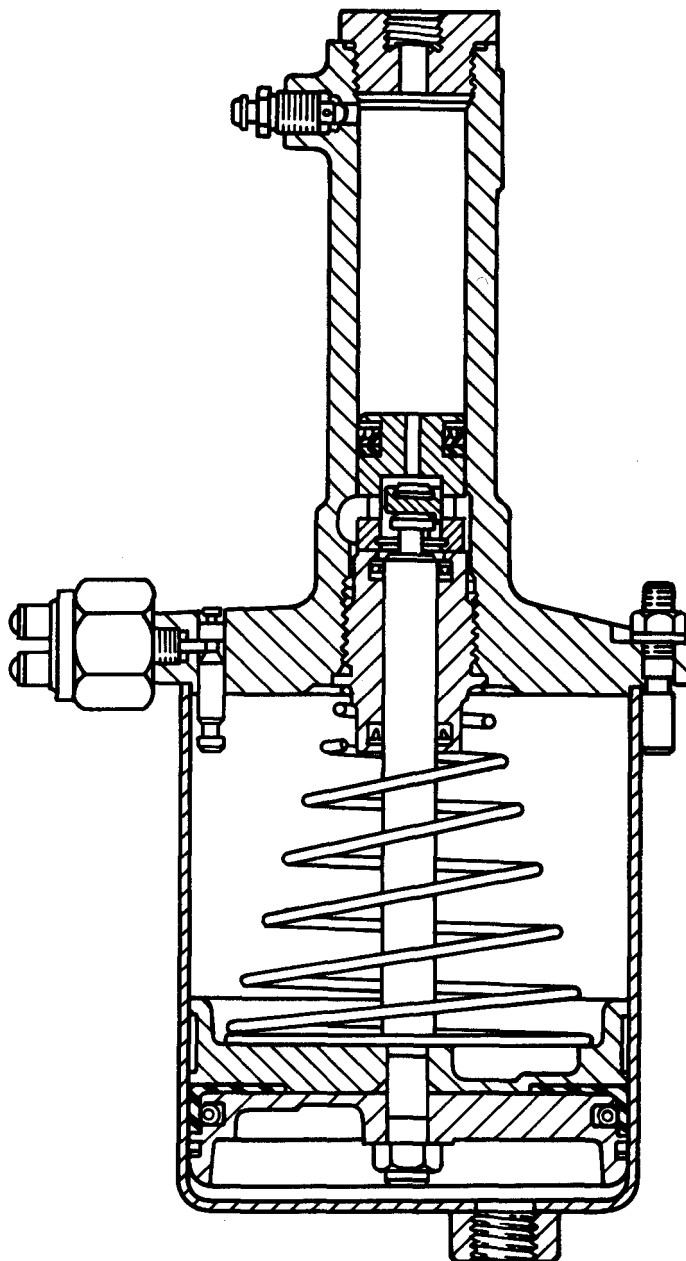

B45331 X1

AIR/HYDRAULIC CYLINDER GROUP

ASSEMBLE AIR/HYDRAULIC CYLINDER GROUP

4258 & 4262-16

Tools Needed		A
1P1854	Pliers	1

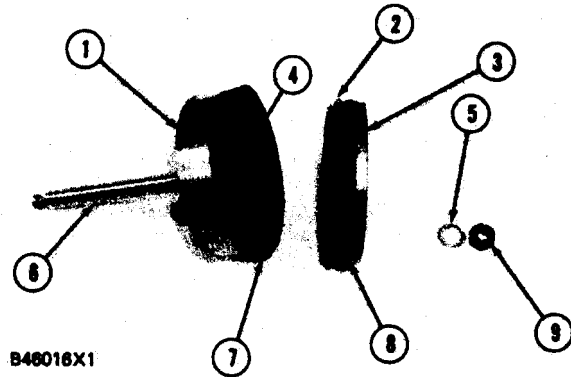

1. Install piston cup (7) on piston (1) as shown.

2. Install piston (1) on shaft (6).

3. Install O-ring seal (4) on shaft (6).

4. Install spring (2) and felt seal (8) on seal carrier (3).

5. Install seal carrier (3) on the piston assembly and install washer (5) and nut (9). Tighten the nut to a torque of 35-45 N•m (25-35 lb. ft.).

6. Install seal valve (11) on retainer valve (10).

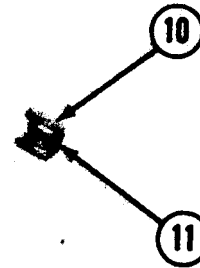

7. Install retaining ring (12) and vee seal (13) on piston (14).

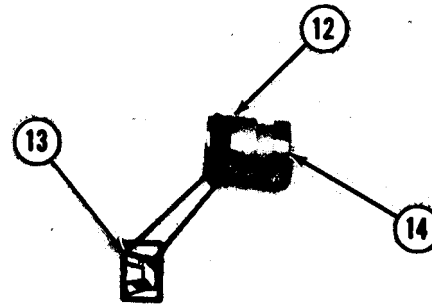

8. Install vee seals (16) and (17) in nut (15) with lip of the seals toward the outside as shown.

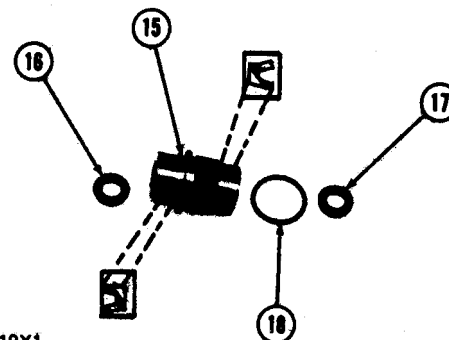

9. Install O-ring seal (18) on nut (15).

AIR/HYDRAULIC CYLINDER GROUP

10. Install spring (24), nut assembly (21), retainer valve assembly (23) and piston assembly (19) on piston assembly (22).

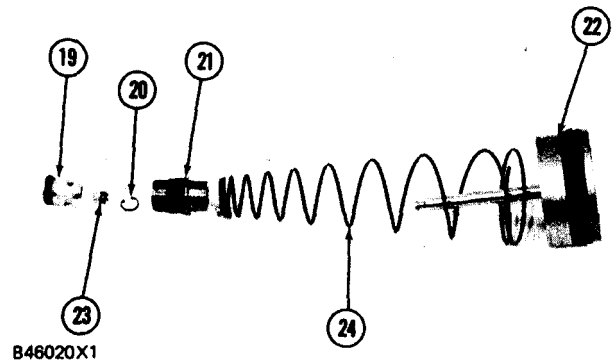

11. Put a small amount of compression on spring (24) and install retaining ring (20) on the shaft with tool (A).

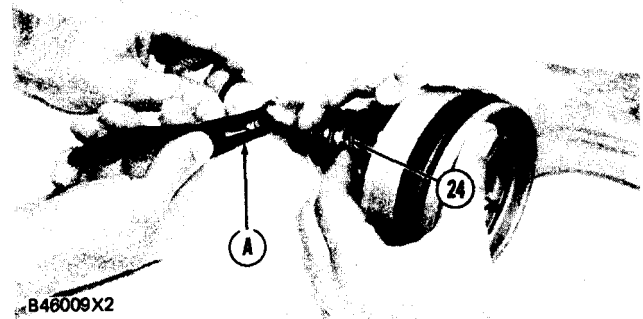

12. Install nut assembly (21) in tube assembly (27).

13. Install cylinder (28) on the piston assembly.

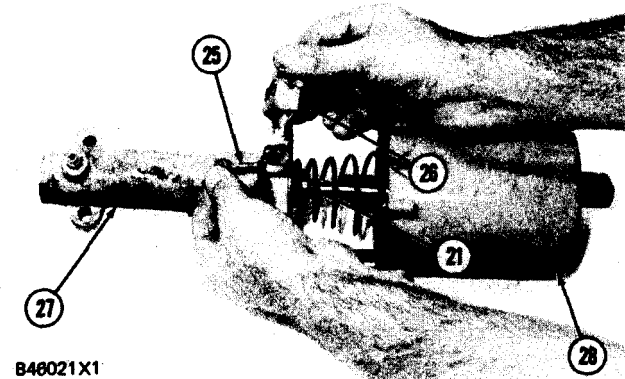

14. Install rod indicator (25) and switch assembly (26) on the tube assembly. Tighten the switch assembly to a torque of 5.4- 10.8 N•m (48 -96 lb.in.).

NOTE: If the plug on the end of tube assembly (27) is removed, tighten it to a torque of 80 N•m (60 lb. ft.).

15. Make a connection of tube assembly (27) and cylinder (28). Install nuts (29) that hold the assemblies together. Tighten the nuts to a torque of 8-16 N•m (6-12 lb. ft.).

end by:

- a) install air/ hydraulic cylinder group.

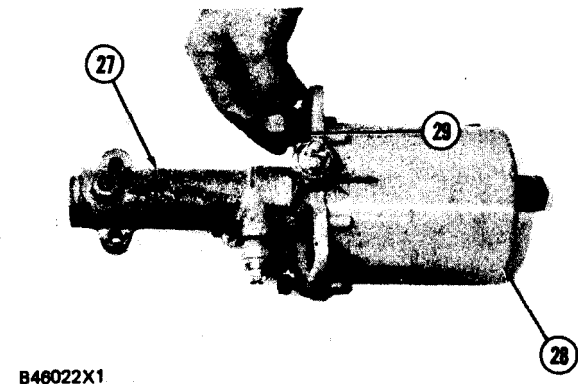

PARKING BRAKE CHAMBER

REMOVE PARKING BRAKE CHAMBER 4353-11

start by:

a) anti-pivot link connection

1. Drain the air from the air tank.
2. Disconnect two wires (2) and air line (1) from the quick release valve.
3. Remove fitting (3) from the quick release valve and install an air fitting.
4. Connect shop air line (4) to the quick release valve.

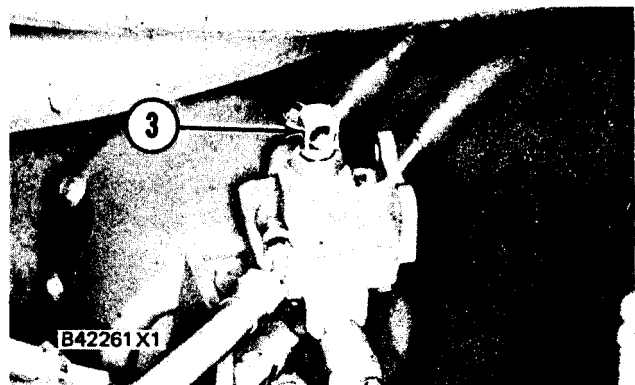
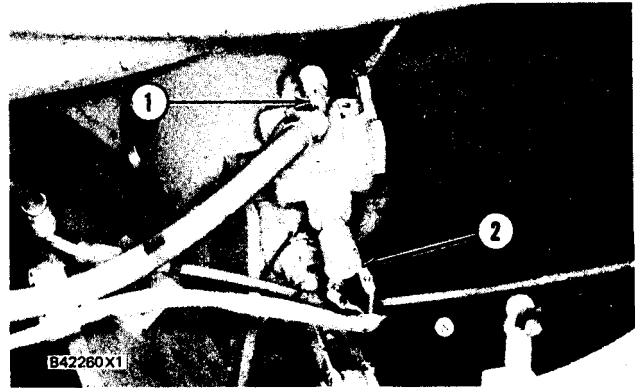

NOTE The shop air must be a minimum of 345 kPa (50 psi).

5. Remove the cotter pin and pin (5) that holds the lever to the yoke.
6. Remove nuts (6) that hold the parking brake chamber on the bracket.
7. Remove the air supply from the quick release valve.
8. Remove parking brake chamber (7) from the machine.

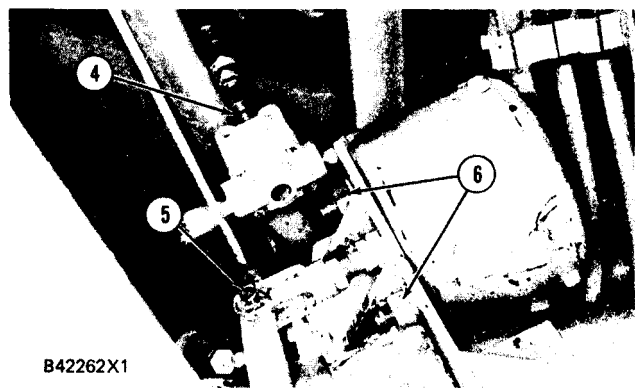

PARKING BRAKE CHAMBER**INSTALL PARKING BRAKE CHAMBER 4353-12**

1. Put parking brake chamber (3) in position on the bracket.

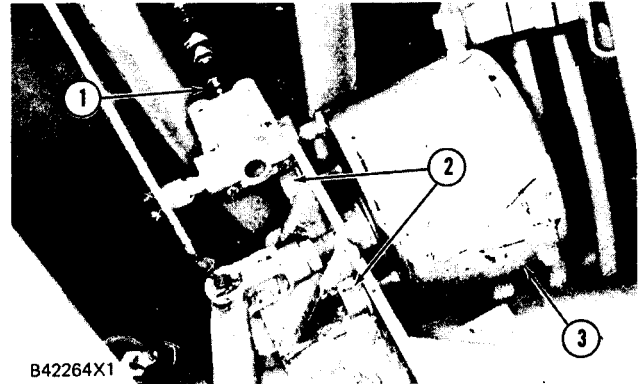

2. Install nuts (2) just enough to hold the brake chamber on the bracket.

3. Connect shop air (1) to the quick release valve.

4. Install pin (6) in the yoke of the brake chamber and lever on the parking brake. Install cotter pin (4) that holds pin (6).

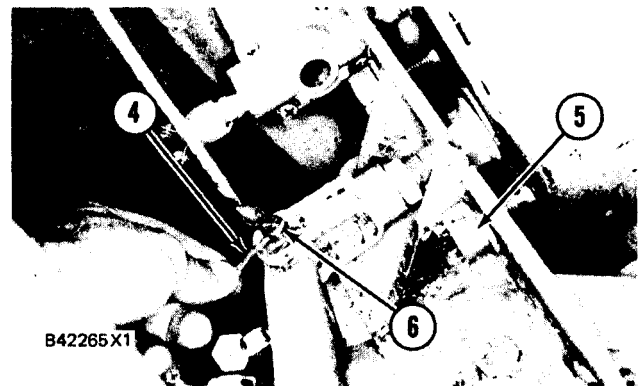

5. Tighten nuts (5) to 150-200 N.m (110-148 lb.ft). Disconnect the air supply from the quick release valve.

6. Remove the air fitting and install fitting (7) to the quick release valve.

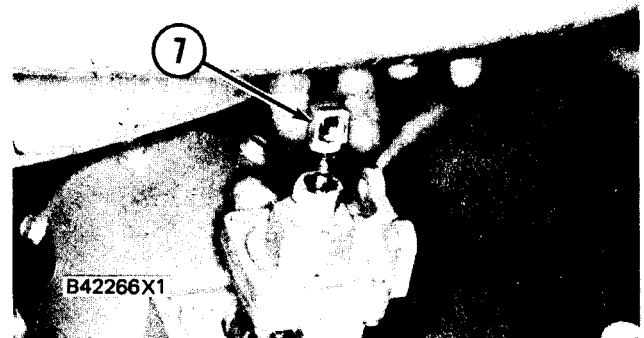

7. Connect air line (8) and wires (9) to the quick release valve.

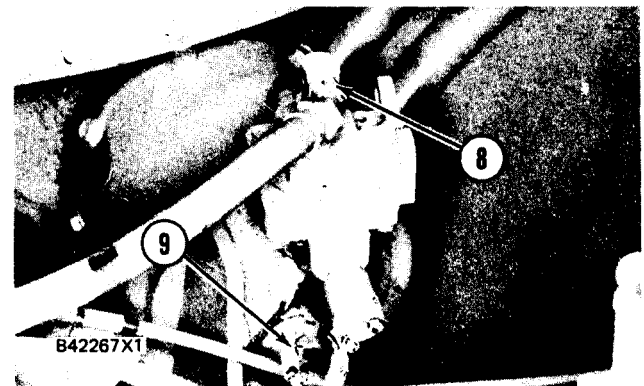

8. Make adjustments to the brake. See PARKING BRAKE ADJUSTMENT, SPECIFICATIONS.

end by:

a) anti-pivot link separation

PARKING BRAKE CHAMBER

DISASSEMBLE PARKING BRAKE CHAMBER

4353-15

Tools Needed		A
5P4776	Stud	1
164209	Nut	3
465278	Washer	2
867548	Puller Assembly (crossbar only)	1

start by:

a) remove parking brake chamber

1. Remove brake quick release valve (1) from the parking brake chamber.
2. For models 950BNS and 950BS, remove four screws (2) and plate (3) from the parking brake chamber.
- 2a. For models 950BNSCE and 950BSCE, remove fiction-fit plug.

WARNING

Spring pressure is present inside the brake chamber. To prevent serious personal injury follow the instructions and use correct tooling.

3. Remove yoke (7), jam nuts (5), nut (6) and stud (4) from the parking brake chamber.
4. Install tooling (A), as shown on the brake chamber. Distance l "X" must be at least 16.5 mm (6.5 in.) when tooling (A) is installed.
5. Tighten nut (10) of tooling (A) a small amount.
6. Remove bolts (8) and plate (9) from the parking brake chamber.
7. Slowly loosen nut (10) of tooling (A) until the pressure of spring is released.

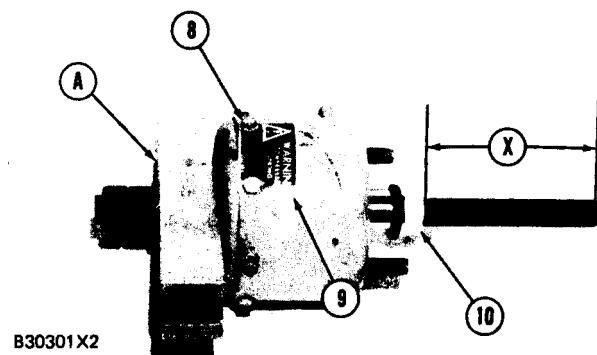
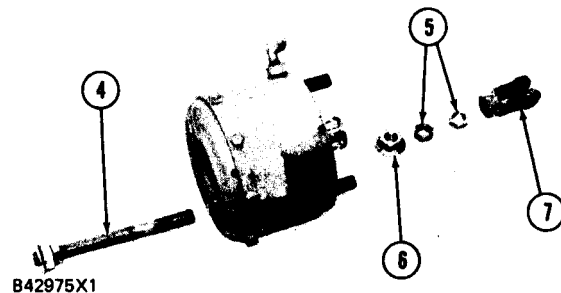
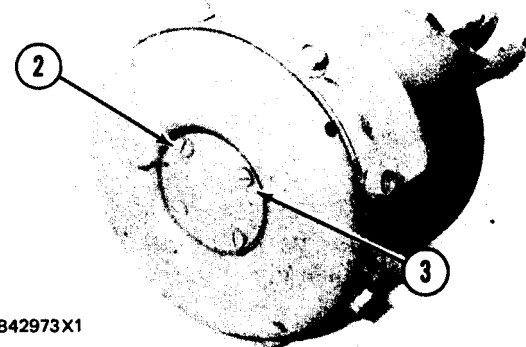

PARKING BRAKE CHAMBER

8. Remove cover (11) and spring (12) from the cylinder.

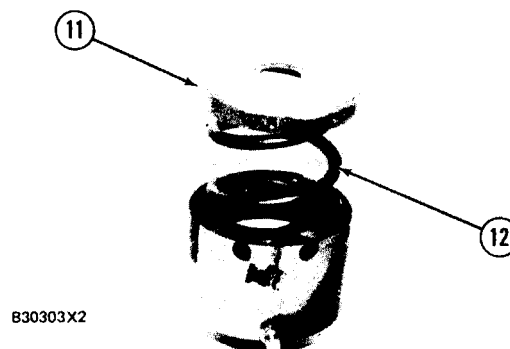

9. Remove piston assembly (14) from cylinder (13).

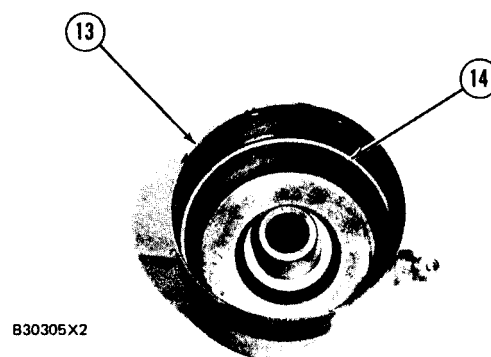

10. Remove seals (15) and (16) from the piston assembly.

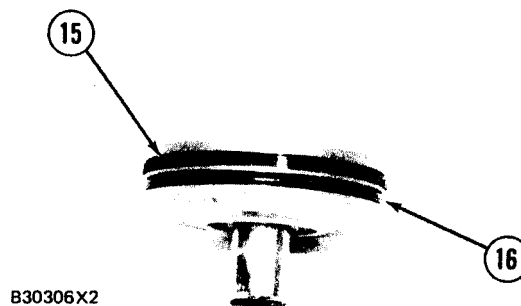

11. Remove seal (17) and the O-ring seal from cylinder (13).

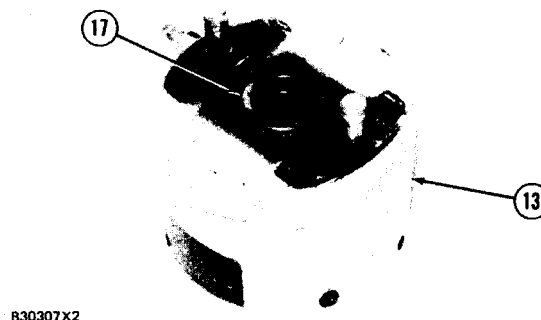

PARKING BRAKE CHAMBER

ASSEMBLE PARKING BRAKE CHAMBER

4353-16

Tools Needed		A
5P4776	Stud	1
5B4209	Nut	3
4B5278	Washer	2
8B7548	Puller Assembly (crossbar only)	1

1. Put O-ring seal(1) and the dust seal in position in cylinder (2).

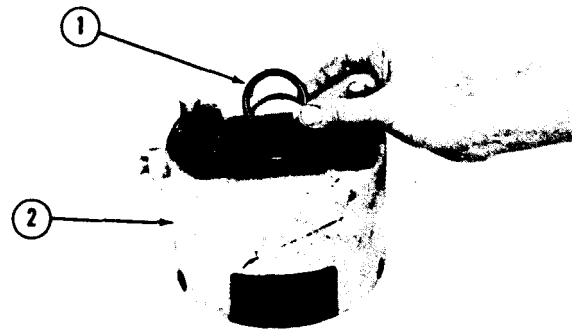

B30308X1

2. Put O-ring seal (3) in position on piston assembly (4).

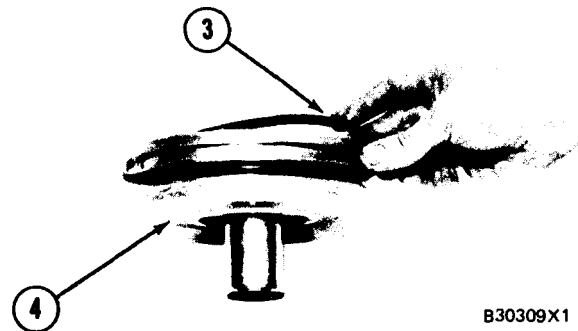

B30309X1

4. Install dust seal (5) on the piston assembly.

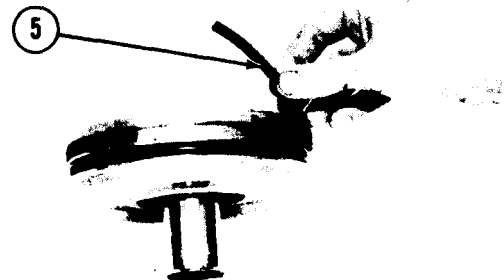

B30310X1

5. Put the piston assembly in position in the cylinder as shown.

6. Put spring (6) and cover (7) in position in the chamber.



B30313X1

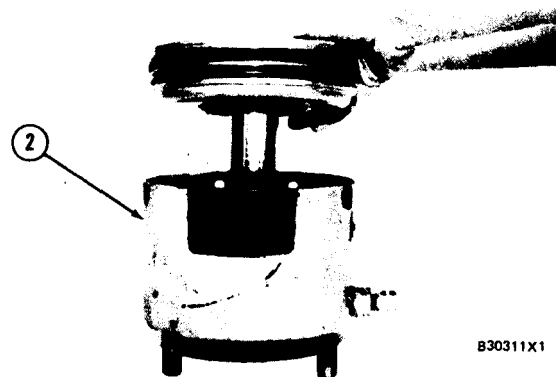

B30311X1

PARKING BRAKE CHAMBER

7. Install tooling (A) on the brake chamber assembly.

8. Tighten the nut and make a compression of spring (6).

9. Install plate (8) and bolts (9). Tighten bolts to 17 ± 3 N-m (13 ± 2 lb.ft). Remove tooling (A) from the brake chamber.

10. Put stud (10) in position in brake chamber (11).

11. Install nut (12), jam nuts (14) and yoke (13) on the stud.

12. For models 950BNS and 950BS, put plate (15) in position and install the four screws that hold the plate in place.

12a. For models 950BNSCE and 950BSCE, install fiction-fit plug.

13. Install brake quick release valve (16) on the parking brake chamber end by:
a) install parking brake chamber

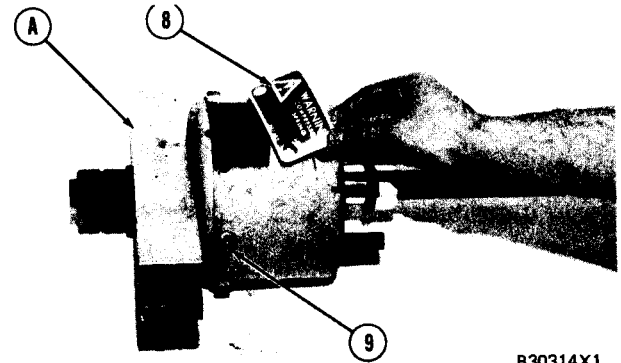

B30314X1

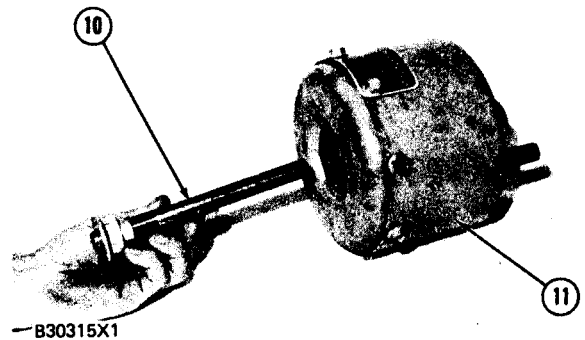

B30315X1

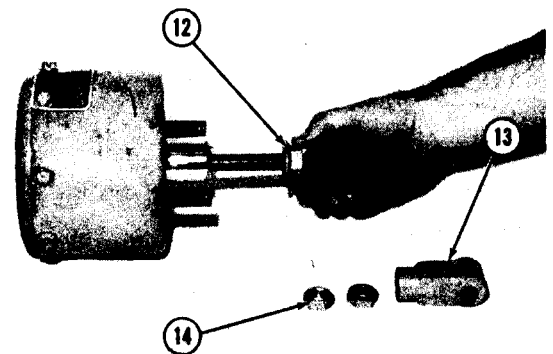

B30316X1

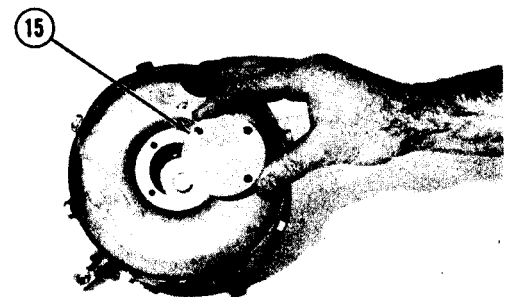

B30317X1

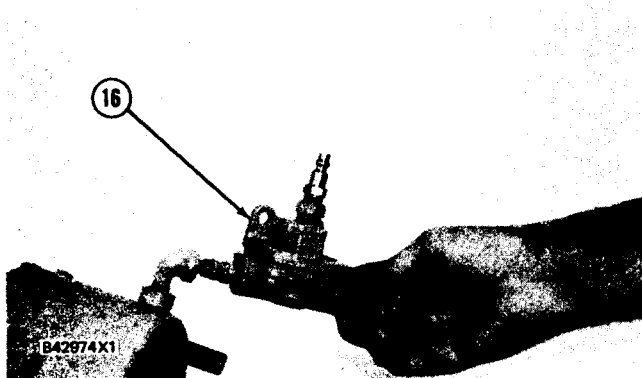

B42974X1

PARKING BRAKE

REMOVE PARKING BRAKE

4353-11

start by:

a) anti-pivot link connection

1. Put the machine on level ground and put blocks in front of and behind the tires so the machine can not move.
2. Put the parking brake switch in the "OFF" or "RELEASE" position.
3. Remove the cotter pin and pin (1) from the link.

NOTE: Put a mark on link (2) and the shaft for assembly purposes.

4. Loosen the bolt that holds link (2) in place,
5. Remove four bolts (3) and clamp (5) from the yoke.
6. Remove the bolts and the clamps from the rear of drive shaft (4) and remove the drive shaft,
7. Remove four bolts (7) and guard (6).
8. Remove bolts (9) and brake drum (8) from the machine.
9. Remove bolt (11), plate (12) and the O-ring seal.
10. Remove yoke (10) from the brakes.

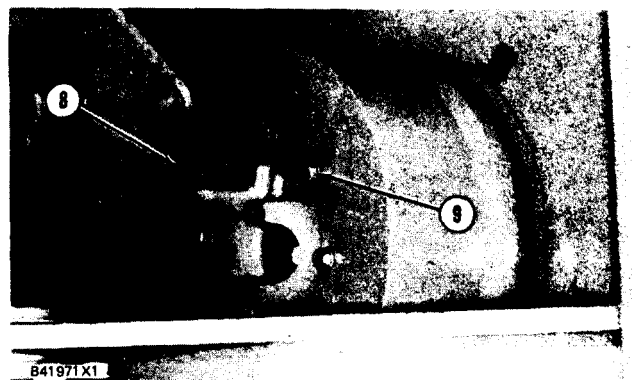
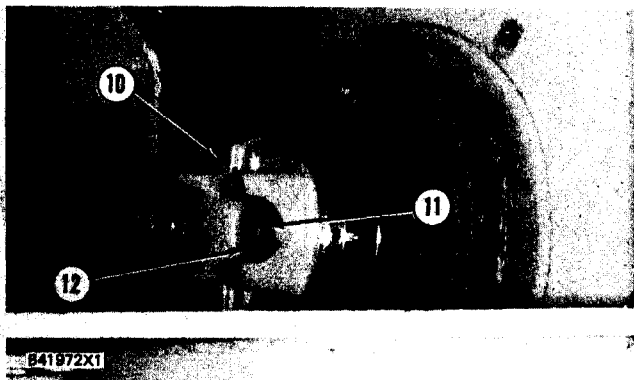
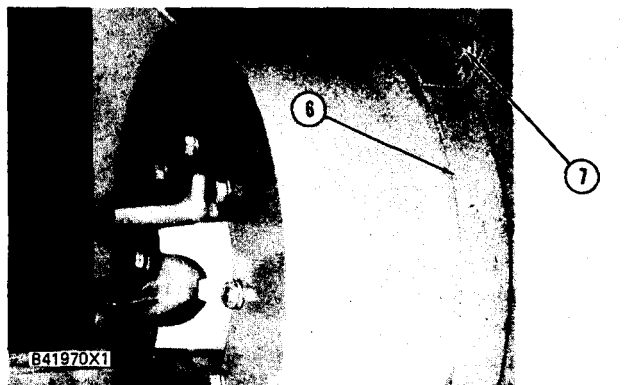
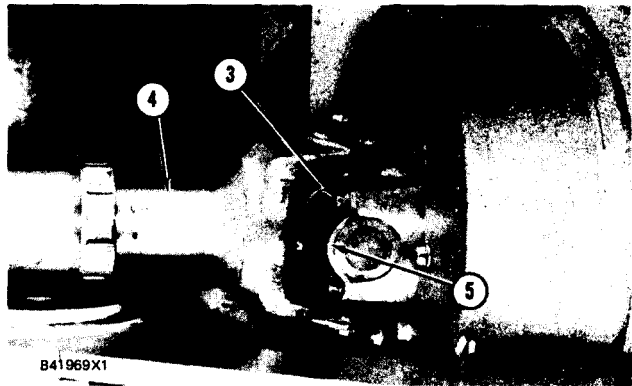
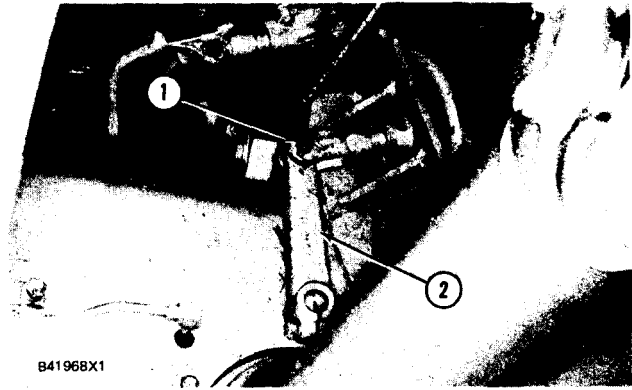

PARKING BRAKE

11. Remove four bolts (13) and brake shoe assembly (14). Link (2) and the spring washer are free to fall when the brake shoe assembly is removed.

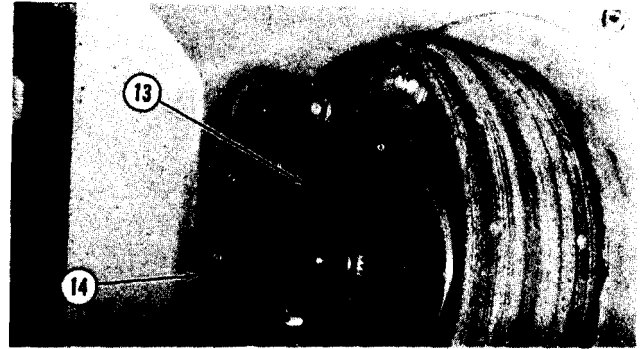

B41973X1

12. Remove two springs (15) and brace (16).

13. Remove cam (17) and plate assembly (18) from the brake shoes.

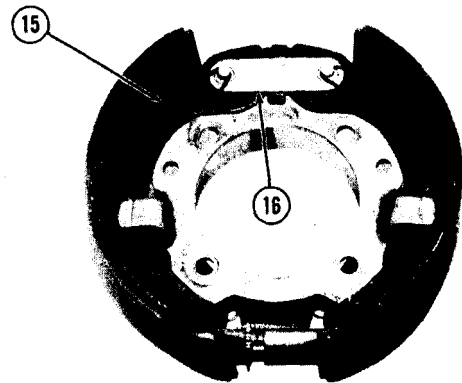

B30044X1

14. Remove spring (19) and adjuster (20).

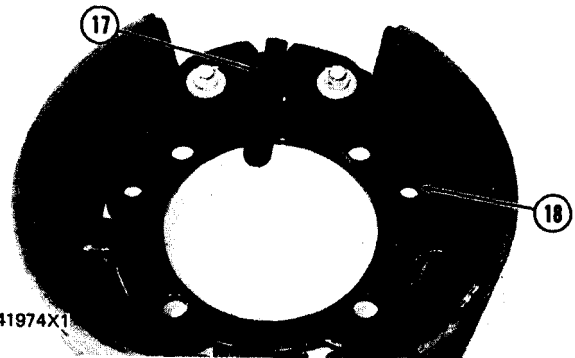

B41974X1

15. Remove socket (21) and screw (22) from nut (23).

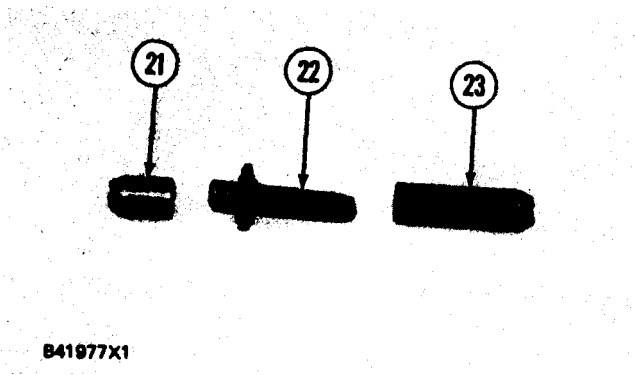

B41977X1

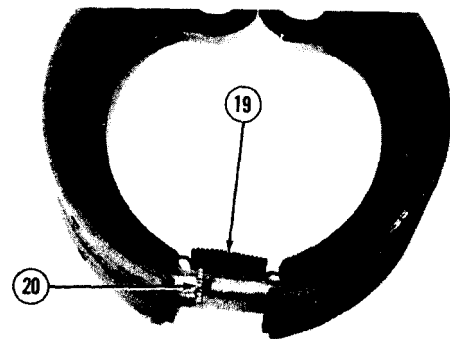

PARKING BRAKE

INSTALL PARKING BRAKE

4353-12

1. Install screw (2) in nut (3).

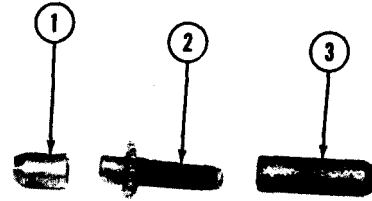

B41975X1

2. Put socket (1) in position on the screw.

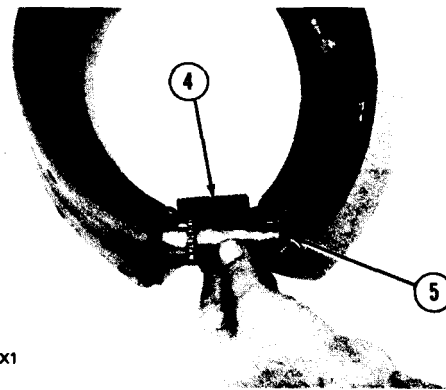

B41978X1

3. Put spring (4) in position on the brake shoes.

4. Put adjuster assembly (5) in position between the shoes as shown.

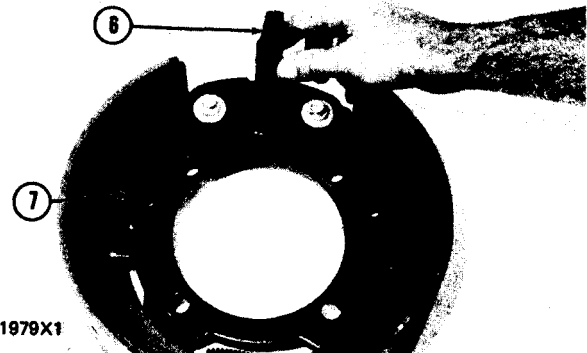

B41979X1

5. Put plate assembly (7) in position and install cam (6).



B30050X1

6. Install brace (9) and springs (8) on the brake shoes.

PARKING BRAKE

7. Put brake assembly (10) in position in the machine.



B42151X1

8. Put the spring washer and link (11) in position on the shaft of the cam. Tighten the bolt that holds the link in position.



B30057X1

9. Install bolts (12) that hold the brake assembly to the machine.

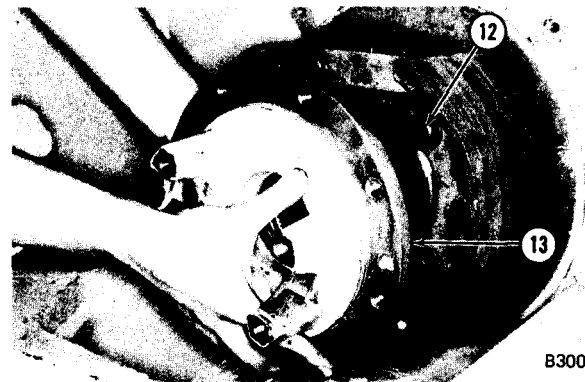

B30052X1

10. Put yoke (13) in position. Make an alignment of the splines in the yoke with the splines on the front drive shaft.

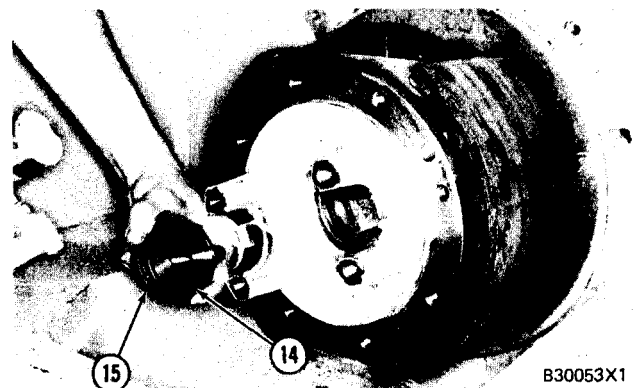

B30053X1

11. Install O-ring seal (14), plate (15) and the bolt. Tighten bolt to 135 ± 15 N-m (100 ± 11 lb.ft).

PARKING BRAKE

12. Put brake drum (16) in position and install bolts (17).



13. Put guard (18) in position around the drum. Install the bolts that hold it in place.

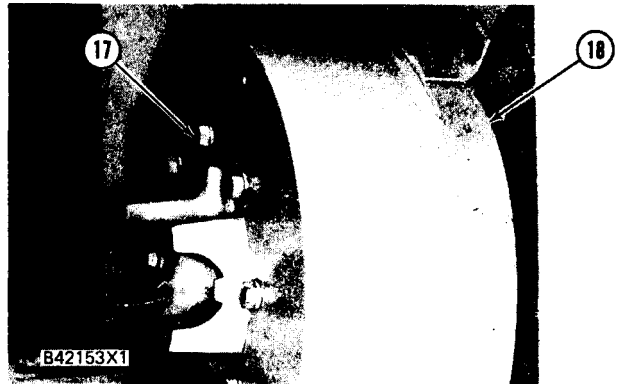

14. Put drive shaft (19) in position and install the clamps and the bolts. Tighten bolts to 55 ± 15 N-m (41 ± 11 lb.ft).

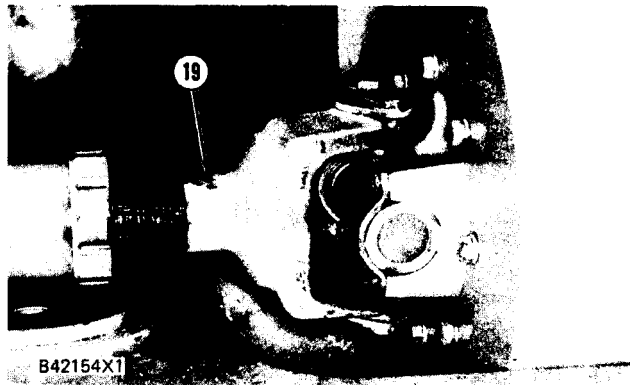

15. Put pin (20) and the cotter pin in position in the link and yoke.

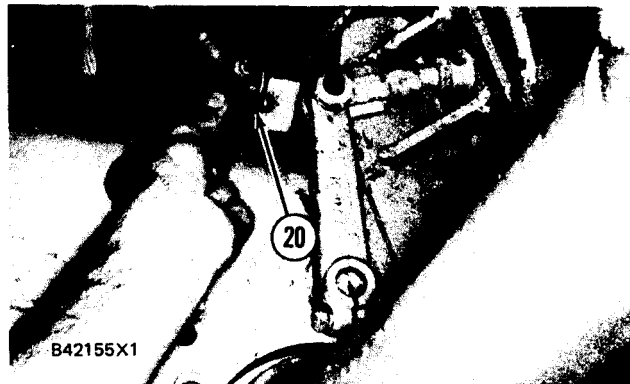

16. Make an adjustment to the parking brake. See TESTING AND ADJUSTING.
end by:
a) anti-pivot link separation

BRAKE QUICK RELEASE VALVE**REMOVE BRAKE QUICK
RELEASE VALVE**

4283-11

1. Release the air pressure from the air tank.

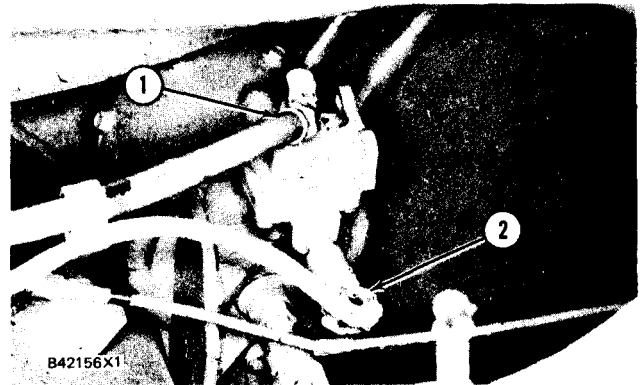

2. Make an identification of all lines.

3. Disconnect air line (1) and two wires (2) from the quick release valve.

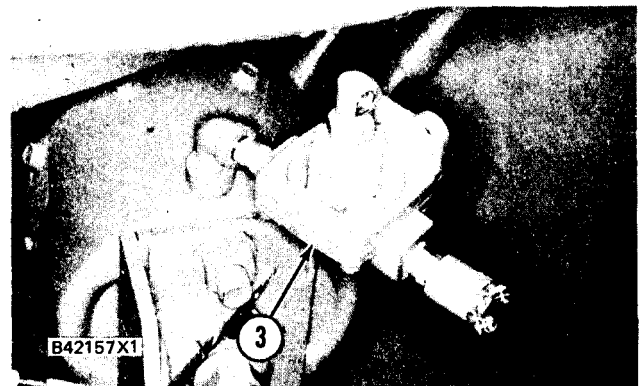

4. Remove the quick release valve (3) from the fitting on the parking brake chamber.

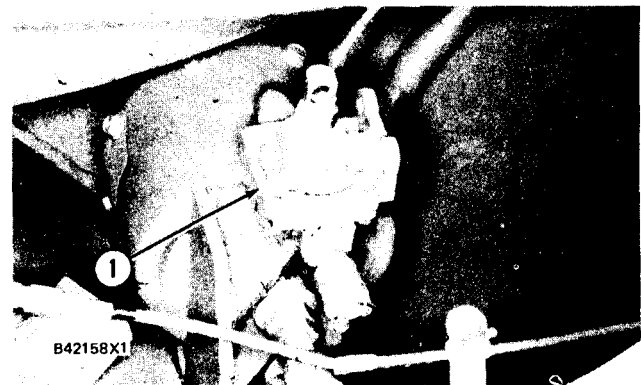
**INSTALL BRAKE QUICK
RELEASE VALVE**

4283-12

1. Install quick release valve (1) on the parking brake chamber.

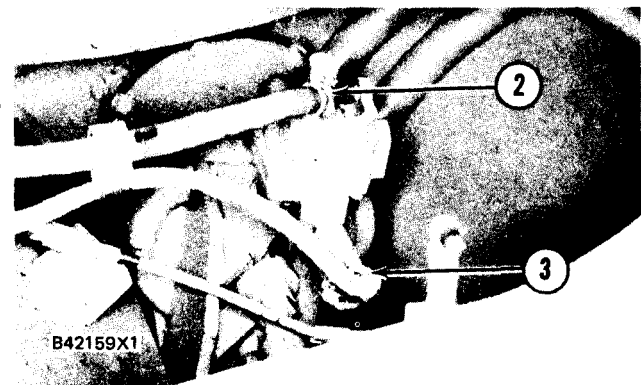

2. Connect air line (2) and wires (3) to the quick release valve.

BRAKE QUICK RELEASE VALVE

DISASSEMBLE BRAKE QUICK RELEASE VALVE

4283-15

1. Remove screws (3) and make a separation of body (1) from body (2).

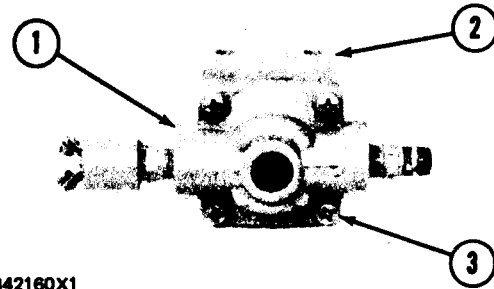

B42160X1

2. Remove O-ring seal (4) from body (2).

3. Remove diaphragm (5) from body (1).

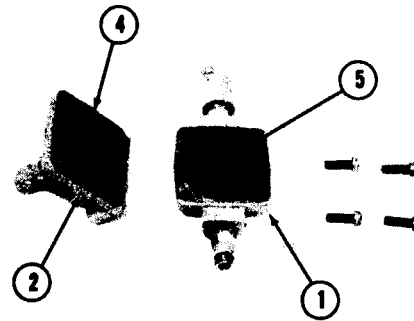

B42161X1

ASSEMBLE BRAKE QUICK RELEASE VALVE

4283-16

1. Install O-ring seal (2) on body (1).

2. Install diaphragm (3) on body (4).

3. Install body (1) on body (4) and install screws (5) that hold the bodies together.

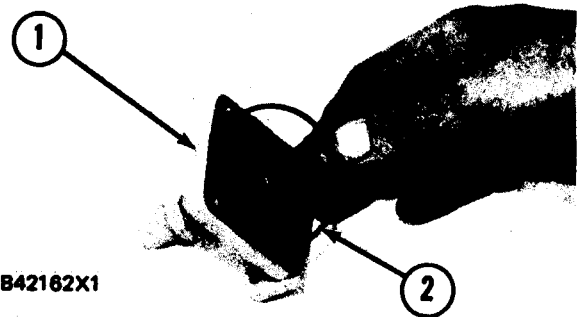

B42162X1

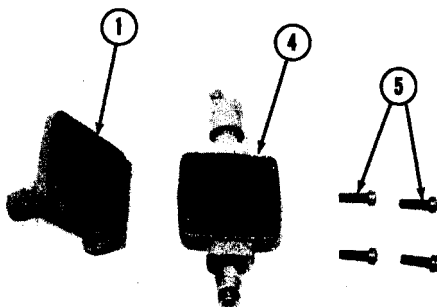

B42161X2

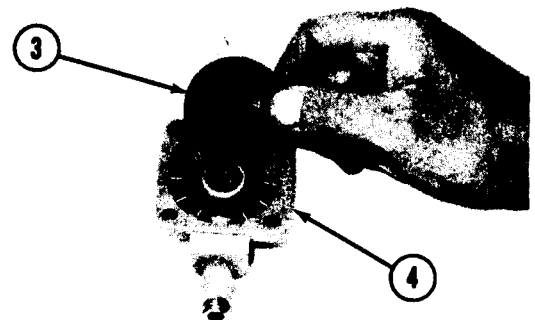

B42163X1

LOADER MAIN FRAMES

Models 950 BNS and 950BS

SEPARATION OF LOADER MAIN FRAMES

7051-29

	Tools Needed	A	B	C	D	E	F	G
5P3100	Pump Group (or electric)	2				1	1	
8S7610	Base Assembly	2						
8S7615	Pin	2	2					
8S7650	Cylinder	2						
8S7640	Stand	2						
8S7611	Tube	2						
6V2157	Link Bracket		2					
2B9886	Hydraulic Jack				1			
8B7554	Bearing Cup Puller Attachment						1	
5P4808	Cap						1	
5P4007	Cap					2		
1P2328	Screw						1	
	Bar Stock 38 x 50 x 200 mm (1 1/2 x 2 x 8 in.)							1
1P1842	Plate							1
8M4839	Adapter							1
1P5558	Stud, 1 1/4 in.						1	1
6V3175	Hydraulic Puller							1
1P544	Nut						1	1
4K684	Washer						1	1
5P7288	Adapter							1
1P1838	Plate							1
6V3170	Hydraulic Puller							1

start by:

- a) connection of anti-pivot link
- b) remove cab and platform
- c) remove center drive shaft

WARNING

To prevent personal injury release the pressure from the hydraulic system before any lines are removed or disconnected.

1. Disconnect lines (1) and (2) on the machine.
2. Remove screws (4) and plate (3) from the transmission neutralizer valve.
3. Disconnect cable assembly (6) from the cam and the neutralizer housing. See REMOVE TRANSMISSION NEUTRALIZER VALVE.

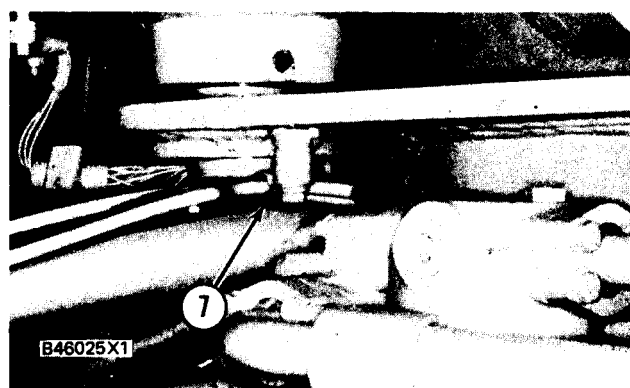
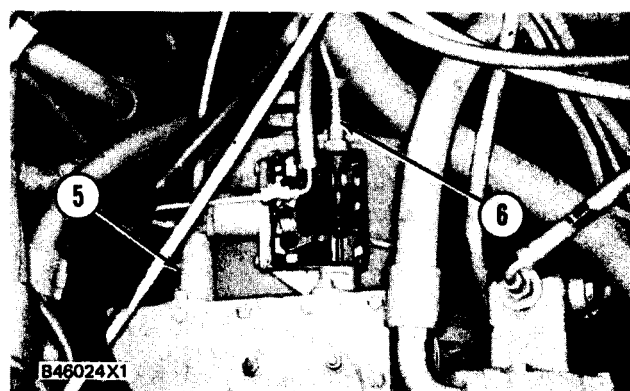
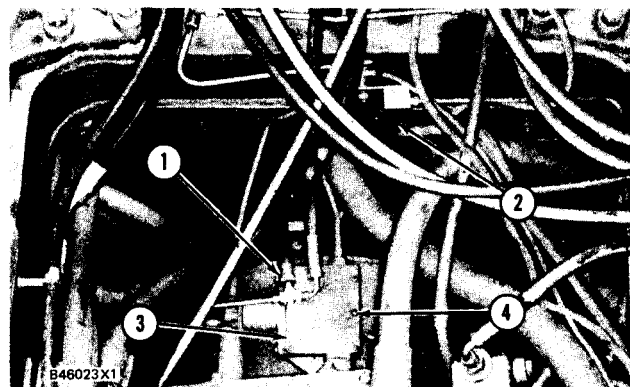

4. Remove the bolts and disconnect transmission selector (5) from the notch (slot) on the valve spool.
5. Remove the bolt and disconnect clip (7) from the front frame.

LOADER MAIN FRAMES

Models 950BNS and 950BS

6. Put identification on wire harnesses (8) and disconnect them.

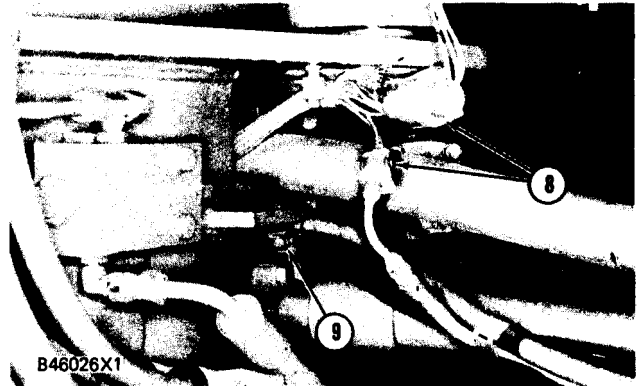

7. Remove bolt (9) and disconnect the clip from the rear frame.

8. Put identification on pilot oil lines (10) and disconnect them from the pilot valve.

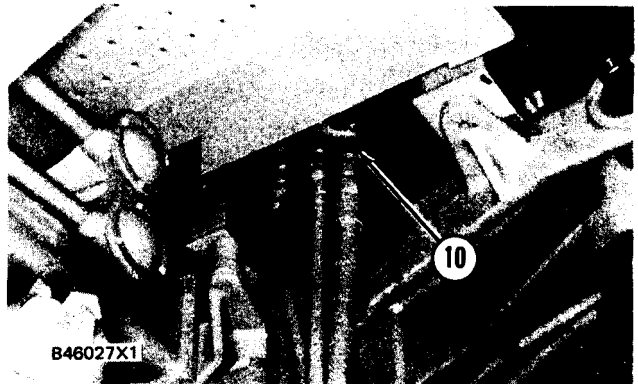

9. Disconnect hydraulic oil line (11) from the selector and pressure control valve.

10. Remove bolt (12) and remove the brackets that hold the pilot control valve lines.

11. Remove the bolts and disconnect hydraulic oil line (13) from the rear frame.

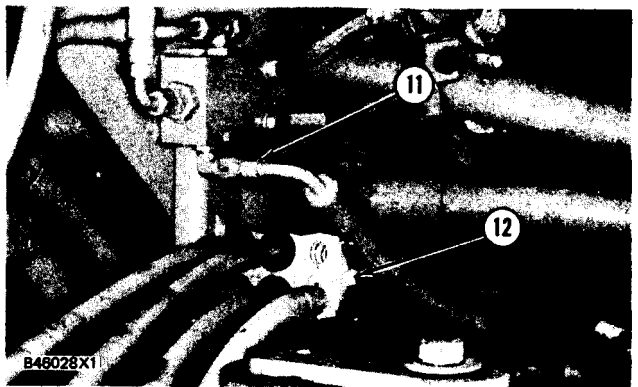

12. Remove bolts (15) and disconnect hose assembly (14) from the loader control valve.

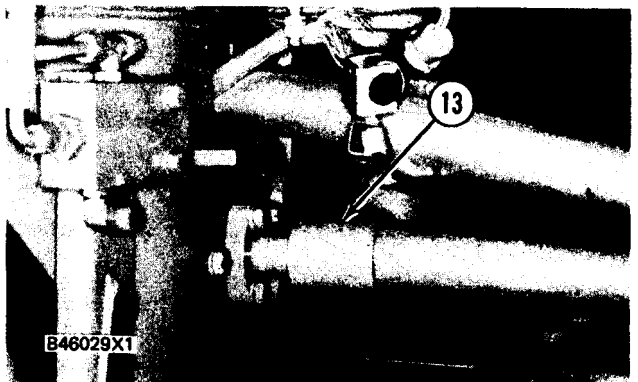
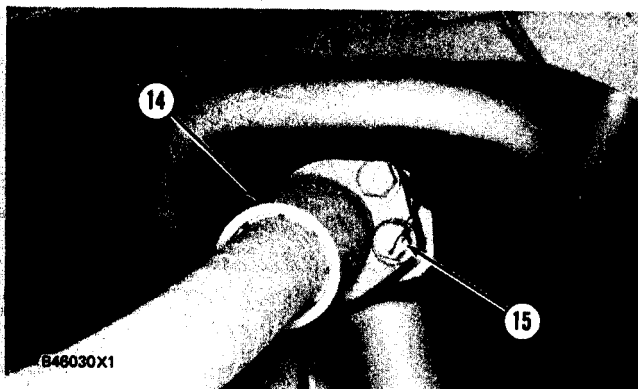

LOADER MAIN FRAMES

Models 950BNS and 950BS

13. Remove bolts (17), the washers and the spacers that hold pins (16) in place. Remove pins (16) from both sides of the machine to disconnect the steering cylinders from the front frame.

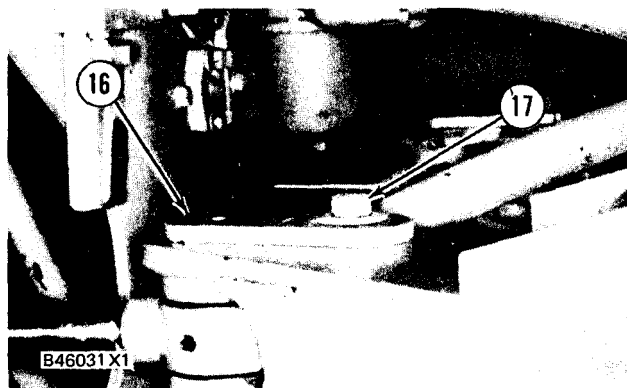

14. Put blocks in front of and behind the tires.

15. Put a block (18) in position between the axle and rear frame on each side to keep the rear frame in the correct position.

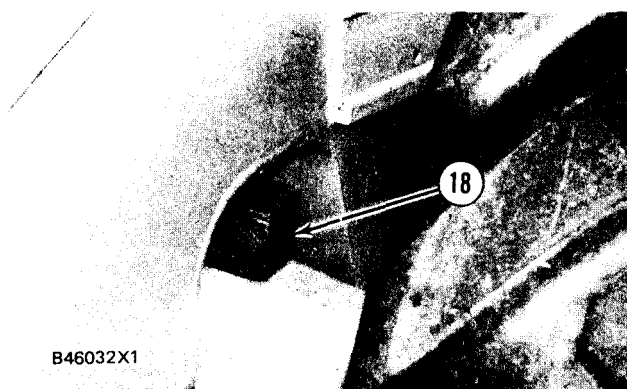

16. Put an approved floor jack (19) under the front of the rear frame.

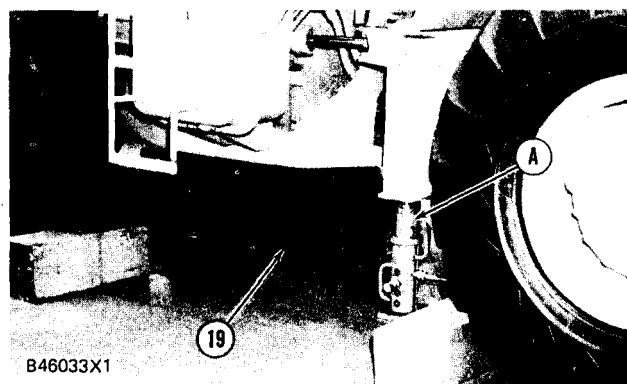

17. Put tooling (A) in position under the front frame as shown.

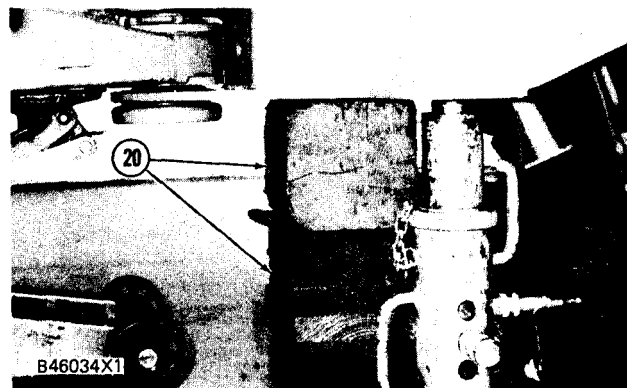

18. Put blocks (20) in position under the front frame to hold it in position as shown.

LOADER MAIN FRAMES

Models 950BNS and 950BS

19. Put a lift truck in position under the rear frame as shown. Fasten it to the frame with a chain or steel cable.



20. Put tooling (B) under rear frame as shown.

21. Remove the bolt and disconnect clips (21) from the rear frame.

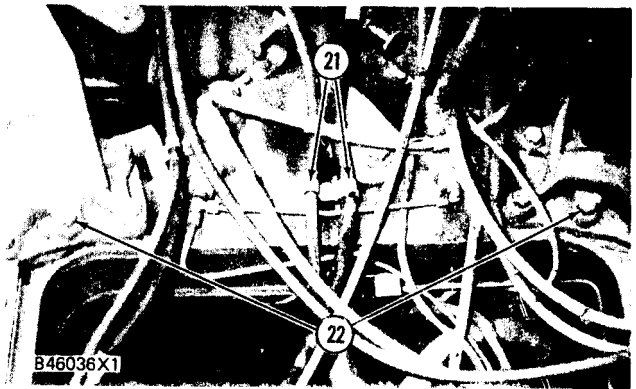

22. Remove bolts (22) from the rear frame.

23. Install tooling (C) and a hoist to the rear frame as shown. The front of the rear frame is heavy by 743 kg (1650 lb.) when hydraulic tank is full and 20% fuel in the tank.

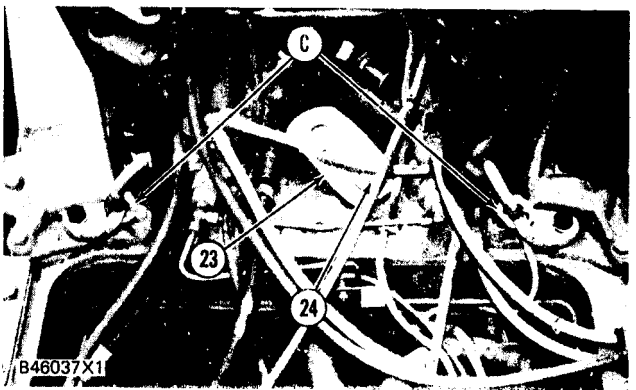

24. Remove bolt (24), the washer and the spacer from pin (23).

25. Use tooling (D) to push out top pin (23).

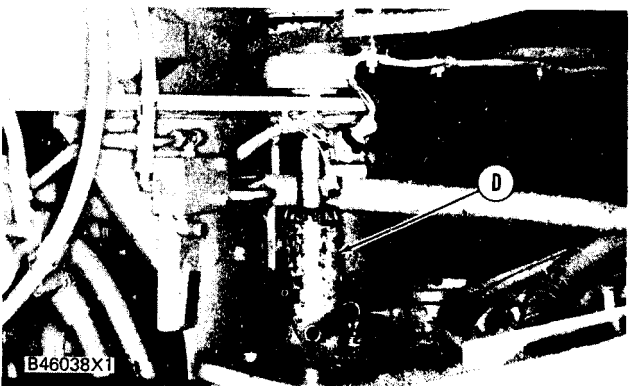

26. Remove bolts (26), cap (25) and the shims from the lower hitch.

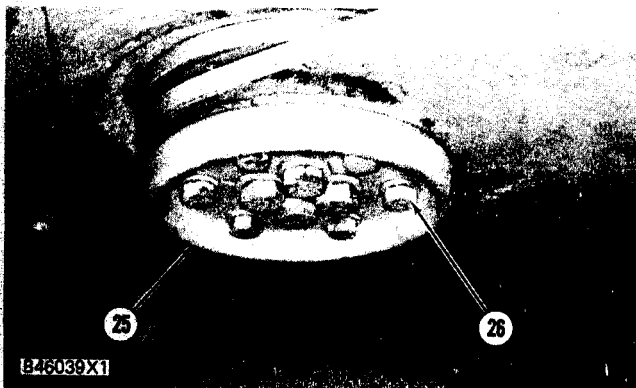

LOADER MAIN FRAMES

Models 950BNS and 950BS

27. If necessary use tooling (E) to remove spacer (27) from the lower hitch.

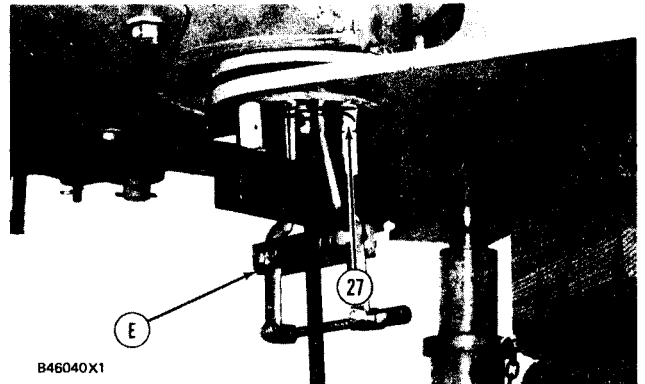

28. If necessary use tooling (D) as shown to remove pin (28) from the lower hitch.

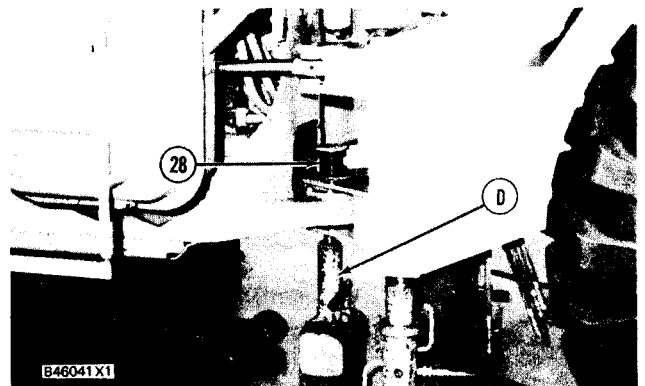

29. Remove pin (30) and pin (29). Make a separation of anti-pivot link (31).

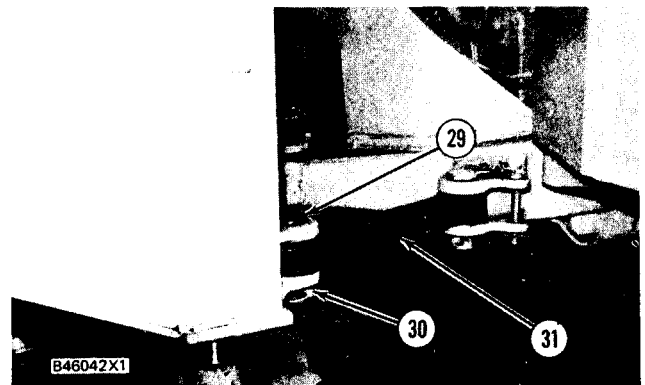

30. Remove tooling (B) and the blocks from the rear tires on the rear frame. Carefully pull rear frame (33) from front frame (32) with the lift truck and hoist.

NOTE: Make sure floor jack (19) stays in position when the rear frame is moved.

31. Remove spacer (34), bolts (35) and two bearing caps (36) from the lower hitch on the rear frame.

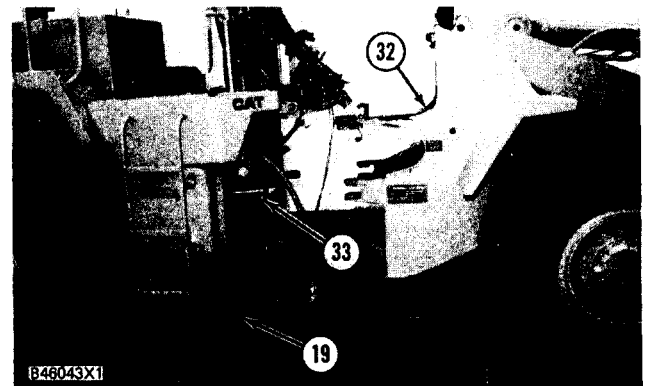
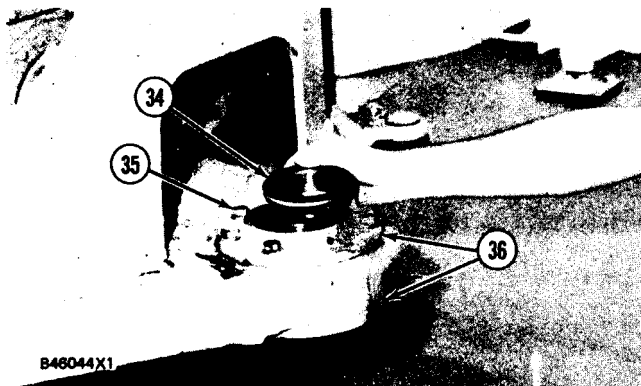

LOADER MAIN FRAMES

Models 950BNS and 950BS

32. Remove lip type seals (37) from bearing caps (36).

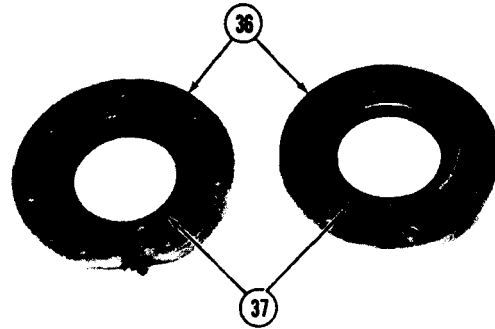

B46045X1

33. Put tooling (F) in position as shown and remove bearing from the lower hitch on the rear frame.

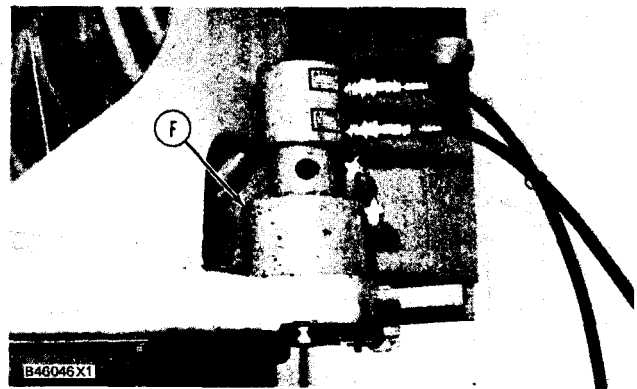

34. Remove lip type seals (38) from the top hitch in the front frame.

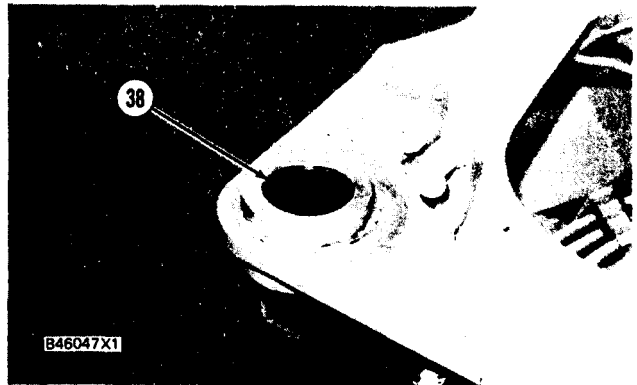

35. Remove retainer rings (39) from the top hitch in the front frame.



36. Use tooling (G) to remove the bearing from the top hitch in the front frame.

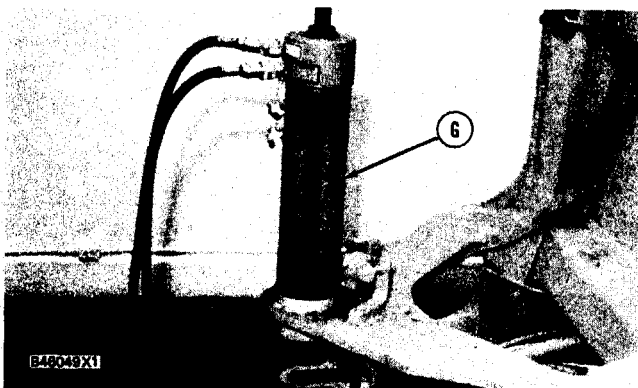

LOADER MAIN FRAMES

Models 950BNS and 950BS

B45332X1

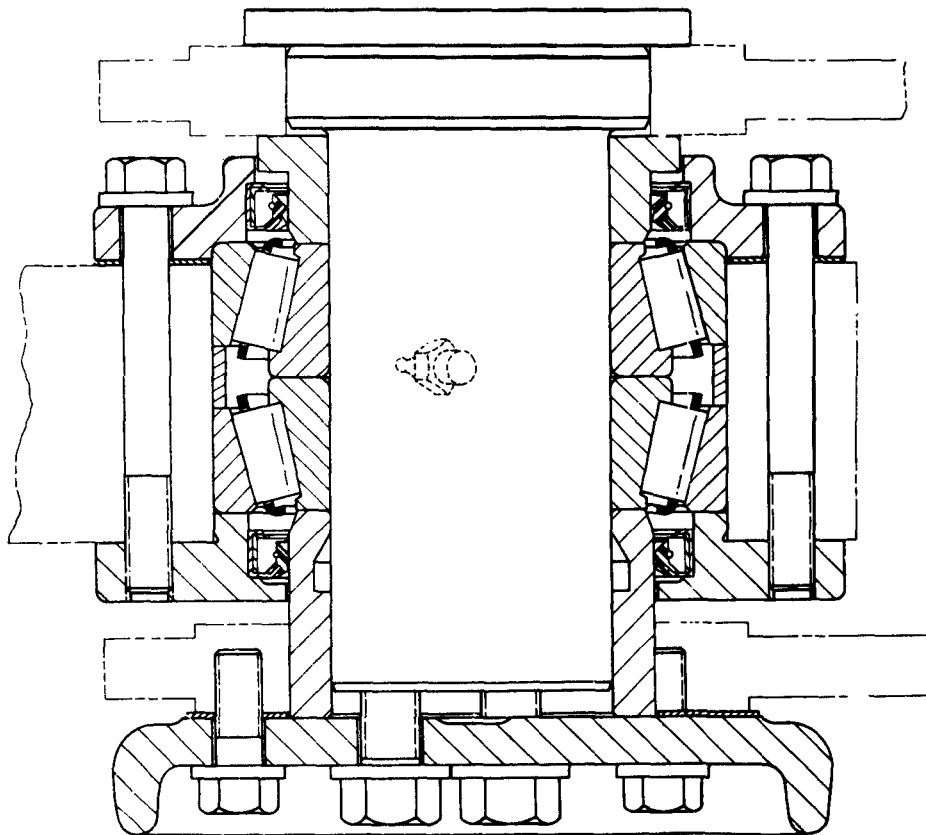
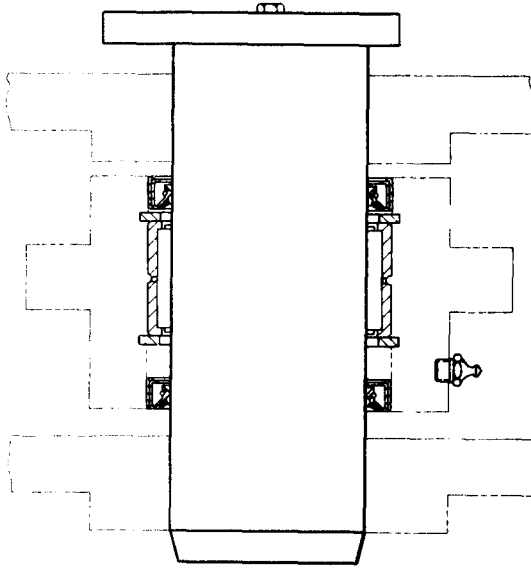

LOADER MAIN FRAMES

Models 950BNS and 950BS

CONNECTION OF LOADER MAIN FRAMES

7051-29

Tools Needed		A	B	C	D	E	F	G	H
5P4758	Pliers	1							
6V3170	Hydraulic Puller	1							
5P7288	Adapter	1							
1P1838	Plate	1							
5P3100	Pump Group (or electric)	1	1					2	
1P5558	Stud, 1 1/4 in.	1	1						
1P544	Nut	1	1						
4K684	Washer	1	1						
1P520	Driver Group		1						
1P1842	Plate		1						
8M4839	Adapter		1						
6V3175	Hydraulic Puller		1						
2B9886	Hydraulic Jack			1					
1P1837	Plate			1					
6V2157	Link Bracket				2				
8S7615	Pin					2	2		
8S7640	Stand					2			
8S7611	Tube					2			
8S7610	Base Assembly					2			
8S7650	Cylinder					2			

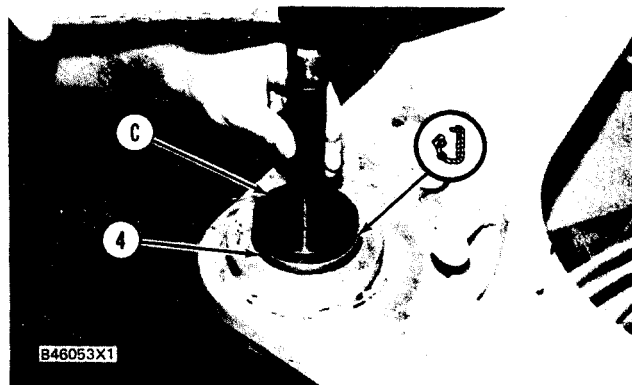
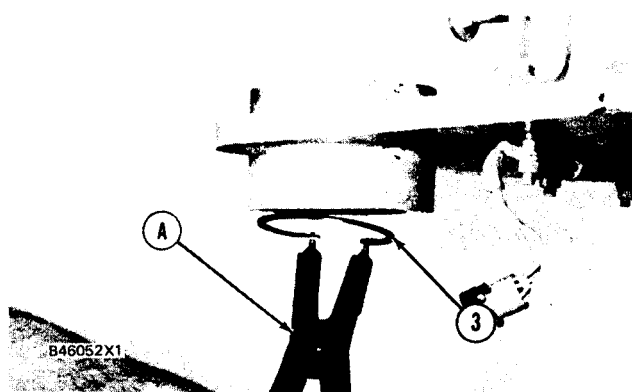
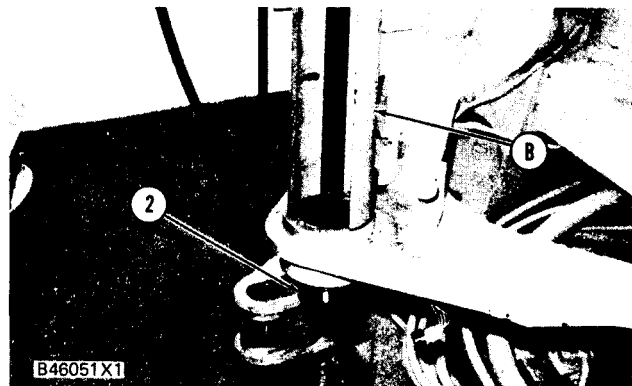
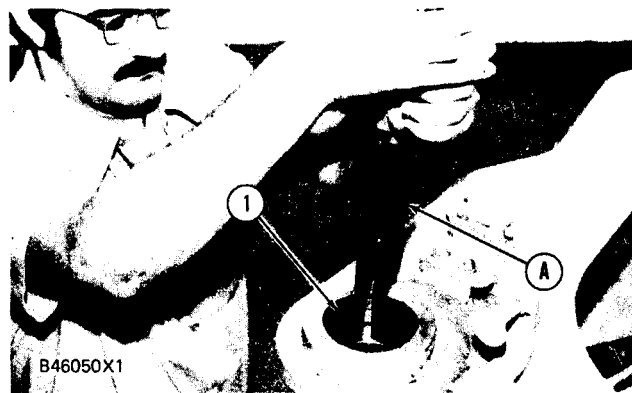

1. Use tool (A) to install top retainer ring (1) in the front frame top hitch.
2. Use tooling (B) to install bearing (2) until it makes contact with ring (1).
3. Use tool (A) to install bottom retainer ring (3).
4. Use tool (C) to install the top lip type seal (4) in the front frame top hitch. The seal must be installed with the lip away from the bearing.

LOADER MAIN FRAMES

Models 950BNS and 950BS

- Use tool (C) to install the bottom lip type seal in the top hitch front frame. The seal must be installed with the lip toward the bearing.

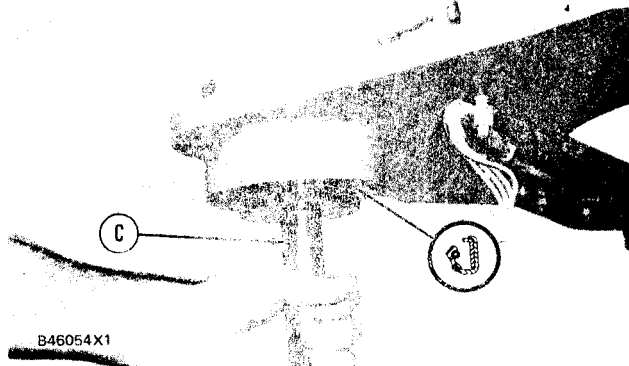

NOTE: Put 5P960 Multipurpose Type Grease on the lips of the seals.

- Use tool (C) to install the lip type seal in upper cap (5). The seal must be installed with the lip up as shown.

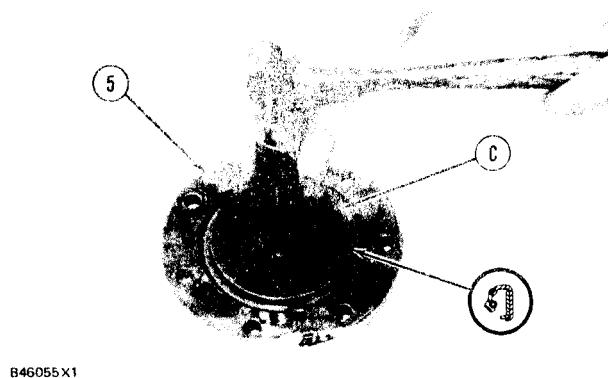

- Use tool (C) to install the lip type seal in lower cap (6). The seal must be installed with the lip down.

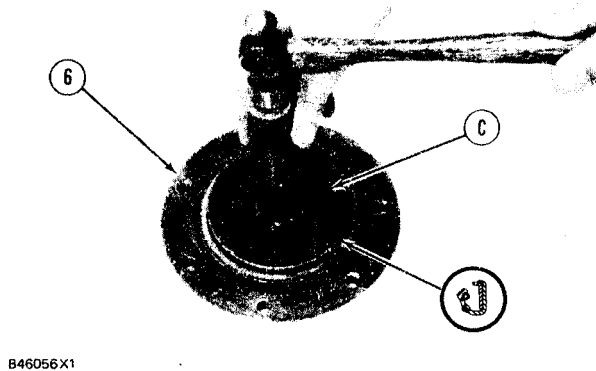

- Install lower cap (6) to the bottom of the lower hitch with three bolts that are even spaces apart to put the bearing assembly in correct position.



LOADER MAIN FRAMES

Models 950BNS and 950BS

9. Install lower bearing cup (7) in the lower hitch of the rear frame as shown. If necessary use tool (C).

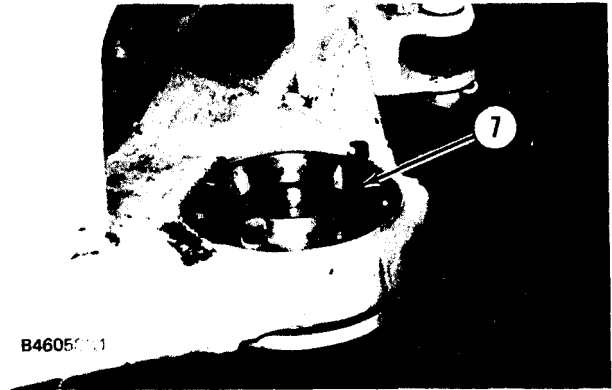

10. Install lower bearing cone (10), spacer (9) and upper bearing cone (8) in the lower hitch of the rear frame as shown. If necessary use tool (C).

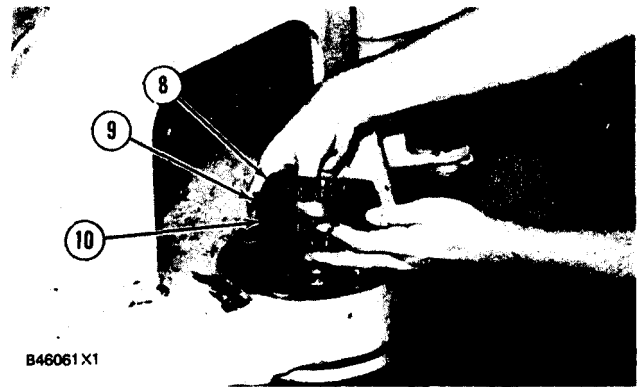

11. Install upper bearing cup (11) in the lower hitch of the rear frame. If necessary use tooling (C).

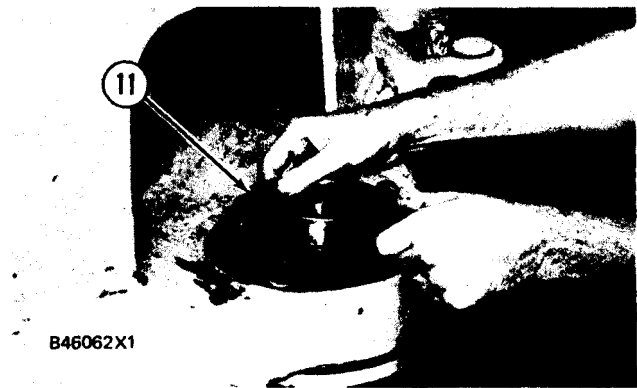

12. Install upper cap (5) and three bolts (12) that are even spaces apart as shown. Tighten the bolts evenly to a torque of 87 N•m (65 lb. ft.). Make sure that lower cap (6) is even with the frame. Measure the gap between upper cap (5) and the frame at the bolts with feeler gauge (13).

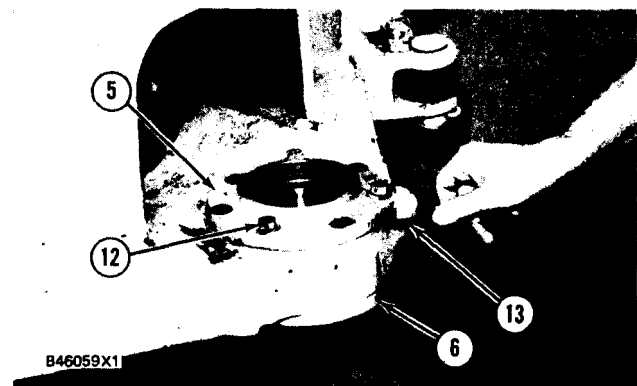

LOADER MAIN FRAMES
Models 950BNS and 950BS

13. Remove the bolts and the caps from the rear frame.

14. Install shims (15) of the minimum thickness found in Step 12. Install upper cap (5), the lower cap and all the bolts.

15. Install spacer (14) in upper cap (5) as shown.

16. Remove the blocks in front of the rear wheels and tooling (G) from the rear of the rear frame.

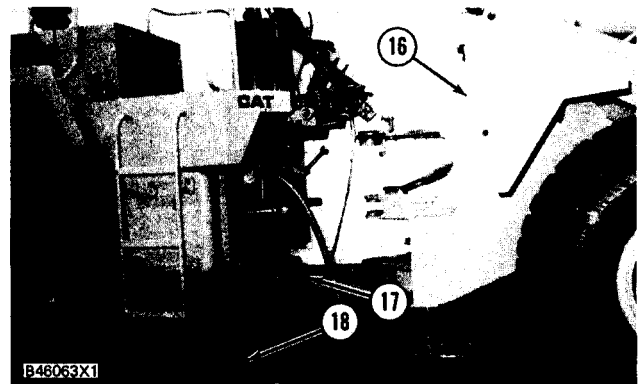
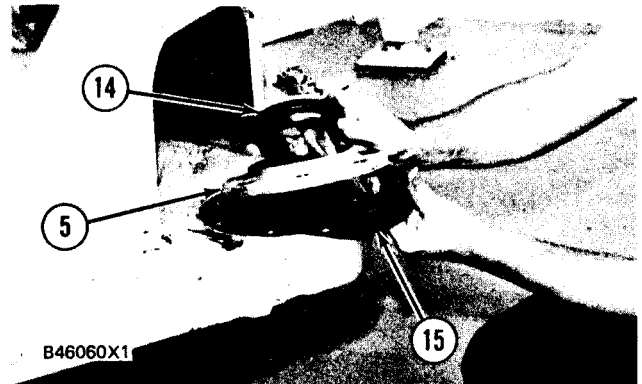
**WARNING**

Make sure floor jack (18) and the hoist are moved with rear frame (17).

17. Use a lift truck and a hoist to connect rear frame (17) to front frame (16).

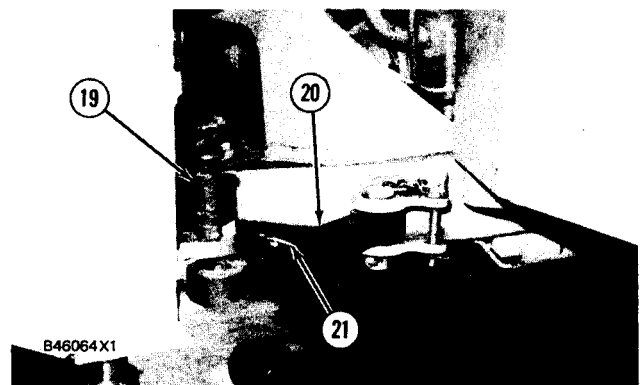

18. Connect anti-Divot link (20) to the front frame with pin (19) and pin (21).

19. Install pin (22) in the upper hitch assembly. Install the spacer, the washer and the bolt that hold pin (22) in place.

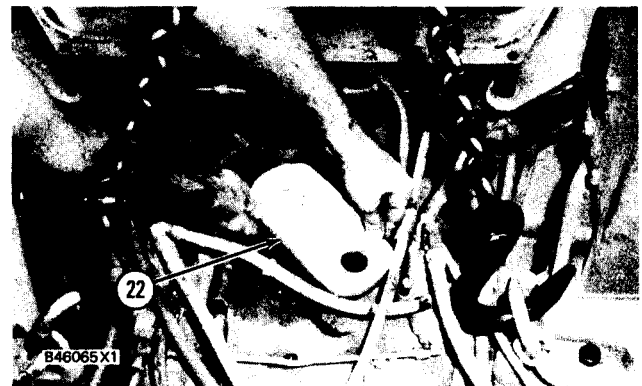

LOADER MAIN FRAMES

Models 950BNS and 950BS

20. Install lower pin (23) in the lower hitch assembly.

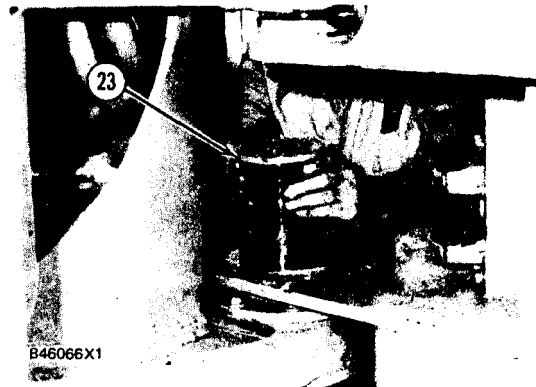

21. Install spacer (24) in the lower hitch. If necessary use tooling (E).



22. Install lower cap (25) and two bolts (26) to the lower hitch assembly as shown.

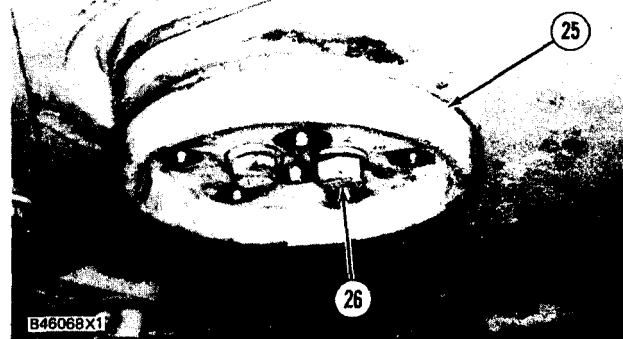

23. If the holes in cap (25) and the holes in the frame are not in alignment, use two 5/8"-11 NC guide bolts to turn cap (25) and the pin as shown.



LOADER MAIN FRAMES

Models 950BNS and 950BS

24. Make sure bolts (26) are 180° apart and tighten them to a torque of 135 N•m (100 lb.ft.).

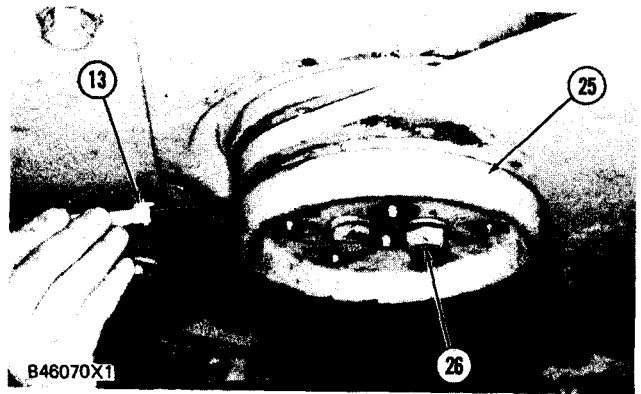

25. Use a feeler gauge (13) to measure the gap around 360° and between cap (25) and the frame.

26. Install shims (27) of the minimum measurement found in Step 25 minus 0.25 mm (0.010 in.).

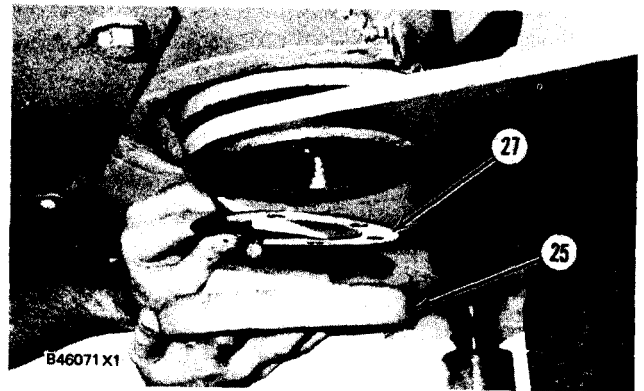

27. Put lower cap (25) in position on the hitch.

28. Install bolts (26) that hold cap (25) and the pin together.

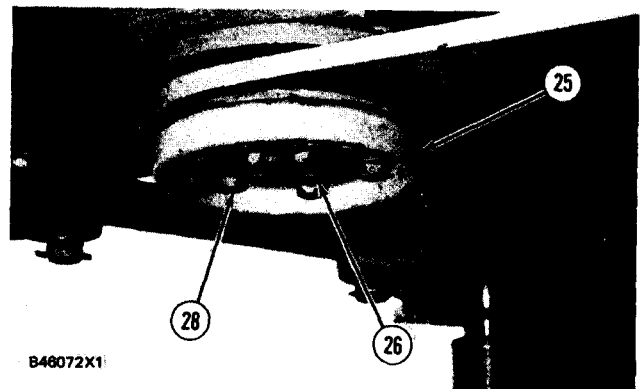

29. Install bolts (28) that hold cap (25) to the frame.

30. Make an alignment of steering cylinders (29) with the front frame.

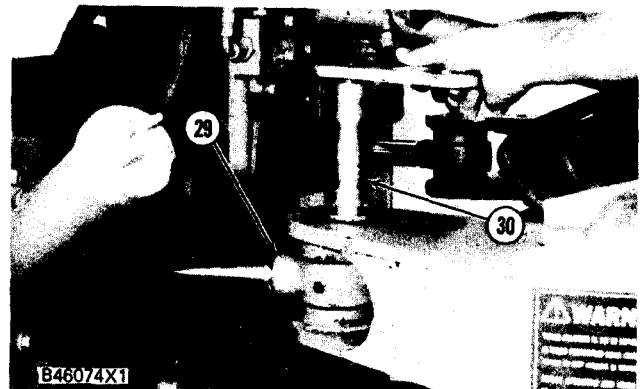

31. Install pins (30) that hold the cylinders to the frame.

LOADER MAIN FRAMES

Models 950BNS and 950BS

32. Install spacers (33), washers (32) and bolts (31) that hold the pins in place.

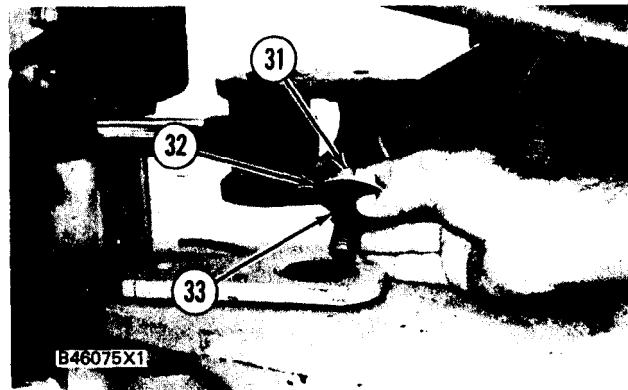

33. Connect tube assembly (34) to the loader control valve.

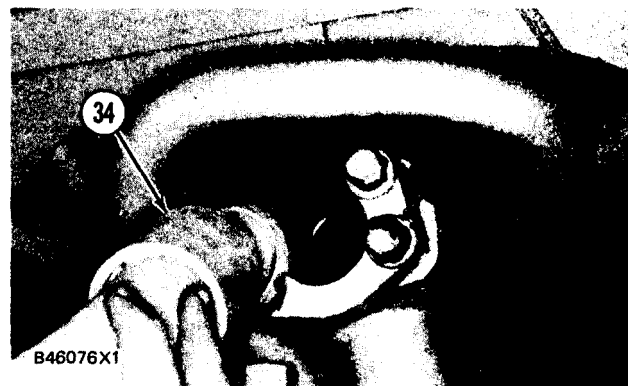

34. Install hydraulic line (35) to the selector and pressure control valve.

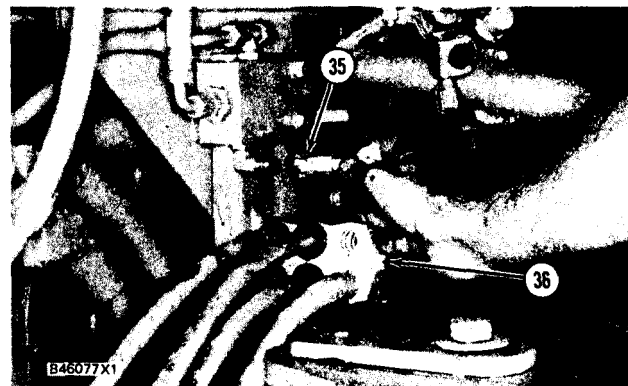

35. Connect wire harnesses (37).

36. Install bolt (38) that holds the clip and hose assembly to the frame.

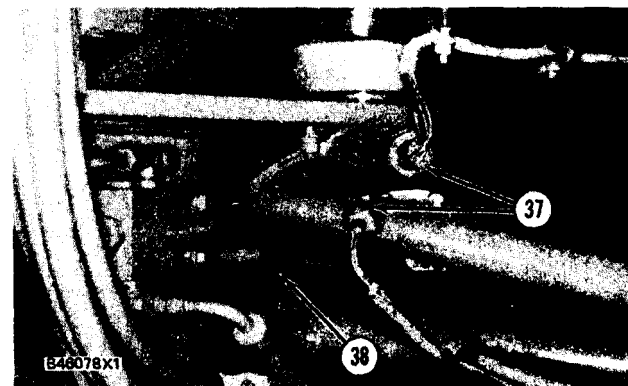

37. Connect oil lines (39) to the pilot control valve.



LOADER MAIN FRAMES

Models 950BNS and 950BS

39. Install bolt (40) that holds the clip and cable assemblies to the frame.

40. Remove tooling (F) and install bolts (43) to the frame.

41. Connect clips (41) that hold the hose assemblies to the frame.

42. Connect clip (42) that holds the wire assembly to the frame.

43. Make sure O-ring seal is in position and connect transmission selector cable (44) in the notch (slot) on the valve spool.

44. Connect cable assembly (45) to cam (46) in the transmission neutralizer group.

45. Make an adjustment to the transmission neutralizer control. See POWER SHIFT TRANSMISSION TESTING AND ADJUSTING.

46. Connect tube assemblies (47) and (48).

47. Remove all tooling from the machine.

48. Remove blocks (49) from between the axle housing and rear frame.
end by:
a) install center drive shaft
b) install cab and platform
c) separation of anti-pivot link

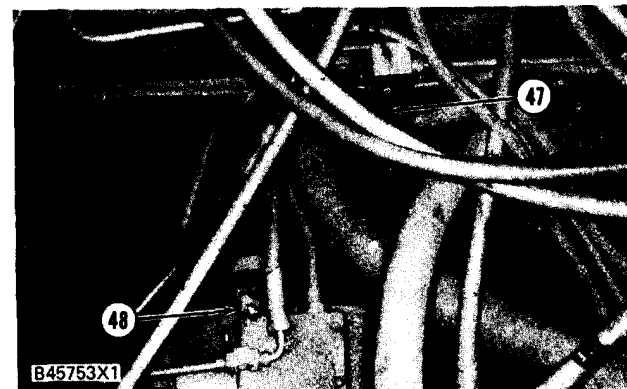
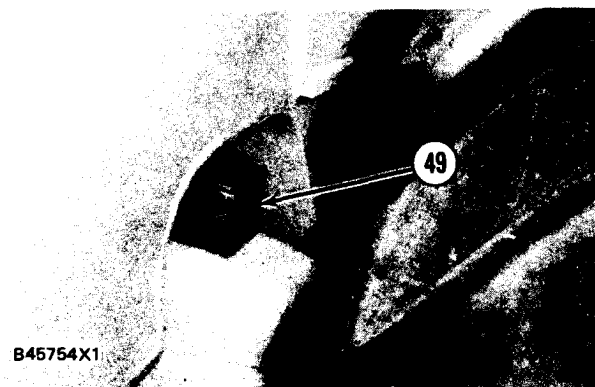
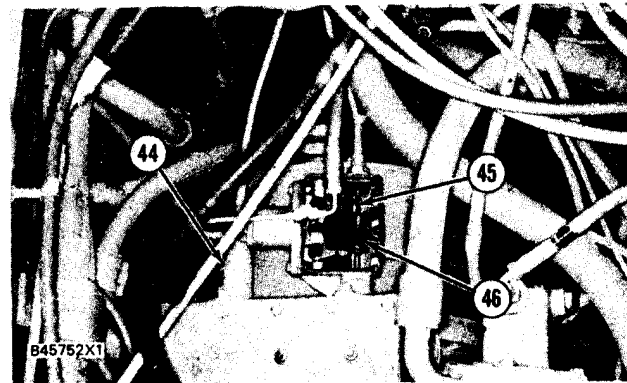
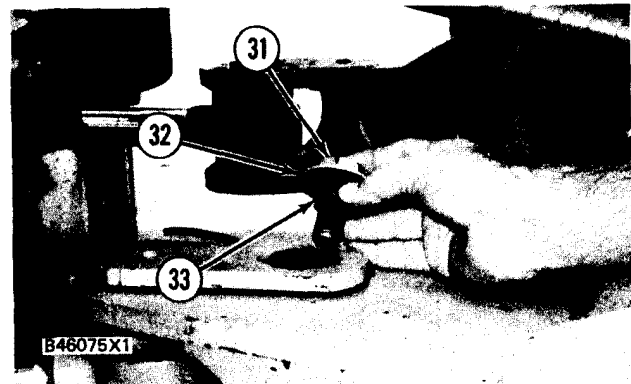
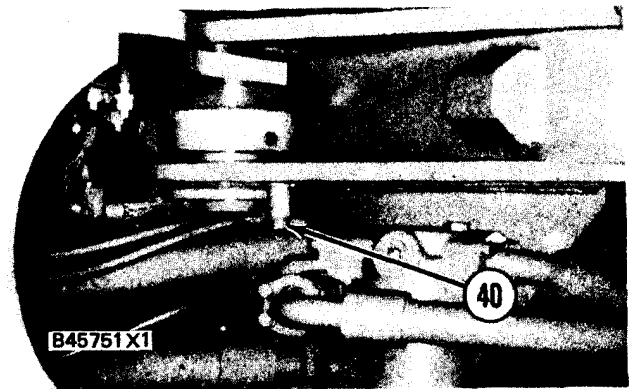

LOADER MAIN FRAMES Models 950 BNSCE and 950BSCE

Separation Of Loader Main Frames 7051-029

Tools Needed		A	B	C	D	E	F	G
5P3100	Pump Group (or electric)	2					1	1
8S7610	Base Assembly	2						
8S7615	Pin	2	2					
8S7650	Cylinder	2						
8S7640	Stand		2					
8S7611	Tube		2					
6V2157	Link Bracket			2				
2B9886	Hydraulic Jack				1			
8B7554	Bearing Cup Puller Attachment					1		
1P2328	Screw					1		
	Bar Stock 38x50x 200 mm (1 1/2 x 2 x 8 in.)					1		
1P1842	Plate						1	
8M4839	Adapter						1	
1P5558	Stud, 1 1/4 in.						1	1
6V3175	Hydraulic Puller						1	
1P544	Nut						1	1
4K684	Washer						1	1
5P7288	Adapter							1
1P1841	Plate							1
6V3170	Hydraulic Puller							1

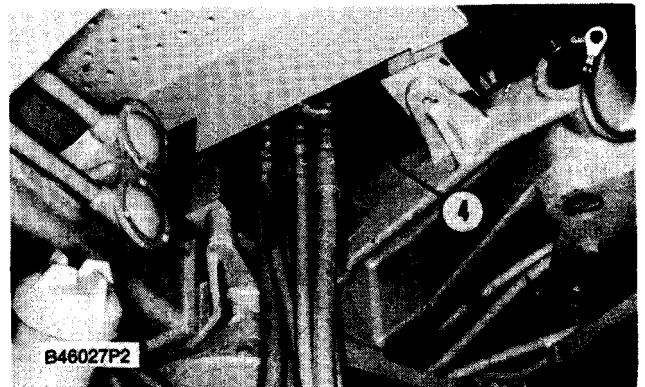
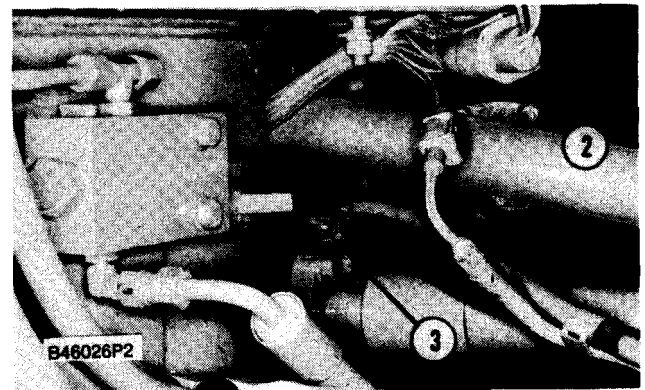
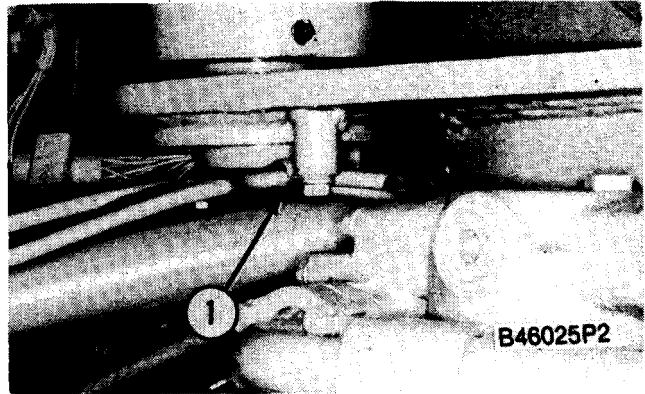

Start By:

- a. connection of steering frame lock link
- b. remove cab and platform
- c. remove center drive shaft
- d. remove transmission neutralizer group

WARNING

To prevent personal injury, release the pressure from the hydraulic system before any lines are removed or disconnected.

1. Remove the bolt and disconnect clip (1) from the front frame.

2. Put identification on wire harnesses (2) and disconnect them.

3. Remove bolt (3) and disconnect the clip from the rear frame.

4. Put identification on pilot oil lines (4) and disconnect them from the pilot valve.

LOADER MAIN FRAMES

Models 950 BNSCE and 950BSCE

5. Disconnect hydraulic oil line (5) from the selector and pressure control valve.

6. Remove bolt (6) and remove the brackets that hold the pilot control valve lines.

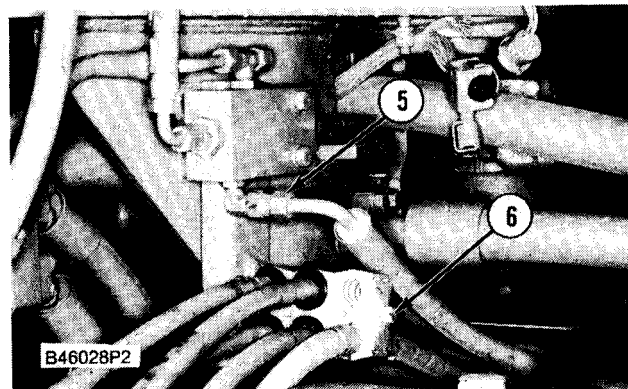

7. Remove the bolts and disconnect hydraulic oil line (7) from the rear frame.

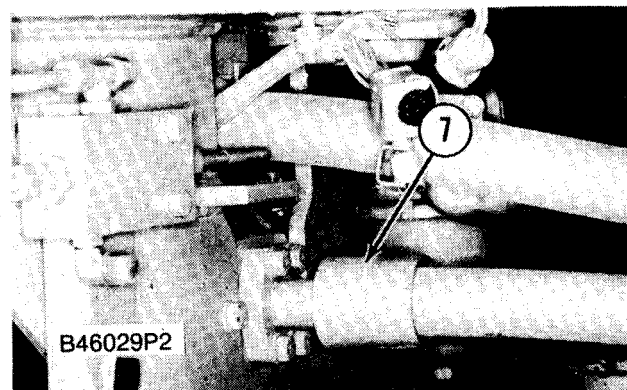

8. Remove bolts (9) and disconnect hose assembly (8) from the loader control valve.

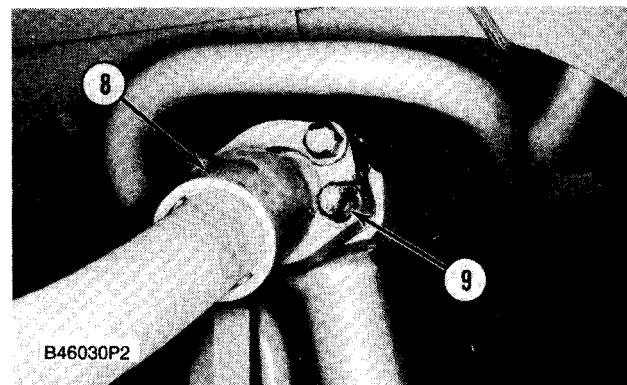

9. Remove bolts (11), the washers and the spacers that hold pins (10) in place. Remove pins (10) from both sides of the machine to disconnect the steering cylinders from the front frame.

10. Put blocks in front of and behind the tires.

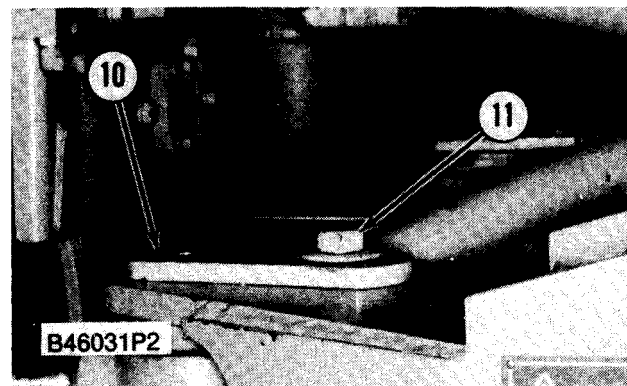

LOADER MAIN FRAMES

Models 950 BNSCE and 950BSCE

11. Put a block (12) in position between the axle and rear frame on each side to keep the rear frame in the correct position.

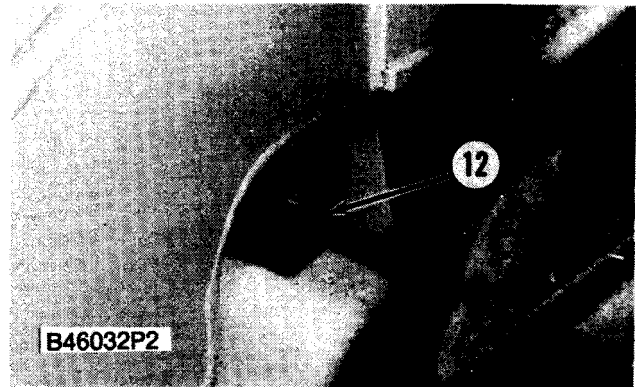

12. Put an approved floor jack (13) under the front of the rear frame.

13. Put tooling (A) in position under the front frame as shown.

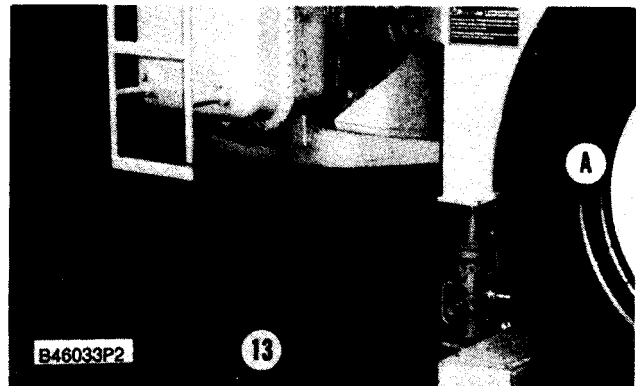

14. Put blocks (14) in position under the front frame to hold it in position as shown.

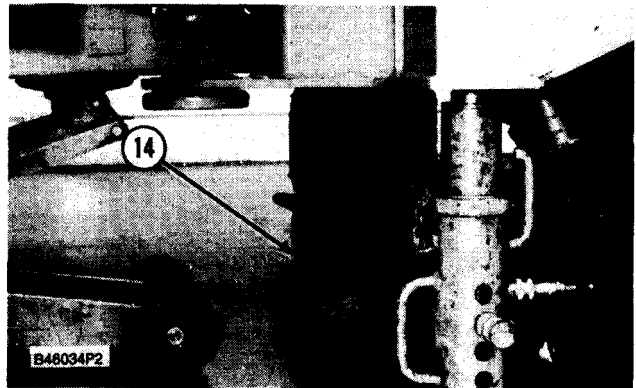

15. Put a lift truck in position under the rear frame as shown. Fasten it to the frame with a chain or steel cable.

16. Put tooling (B) under rear frame as shown.

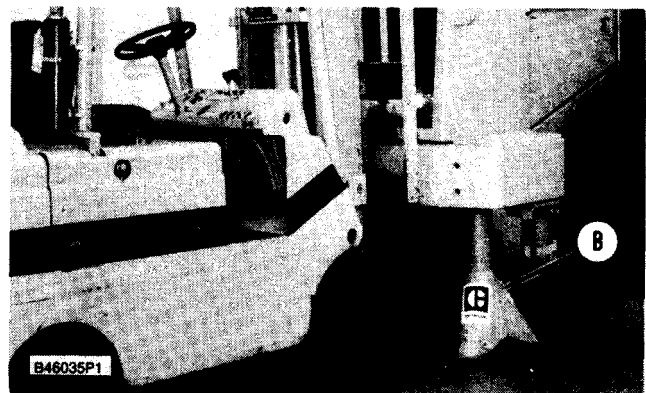

LOADER MAIN FRAMES Models 950 BNSCE and 950BSCE

17. Remove bolts (15). Install tooling (C) and a hoist to the rear frame where bolts (15) were removed. The front of the rear frame is heavy by approximately 743 kg (1650 lb.) when the hydraulic tank is full, and the fuel tank is 20% full.

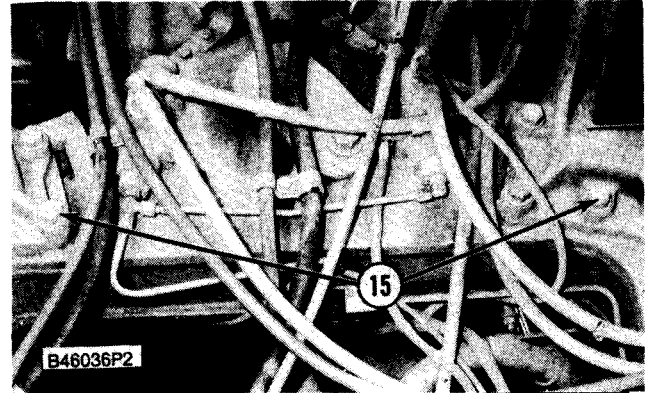

18. Remove bolts and washers (17) and (19) that hold the hose clips. Move hoses (20) away from cover (18).

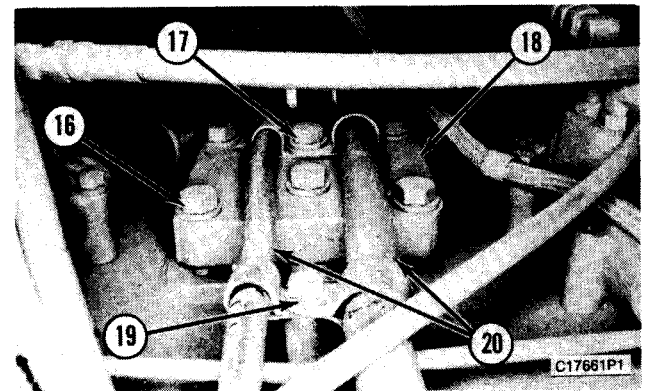

19. Remove bolts and washers (16). Remove cover (18).

20. Use tooling (D) to push out pin (27). Remove collar (21) from the upper hitch of the rear frame.

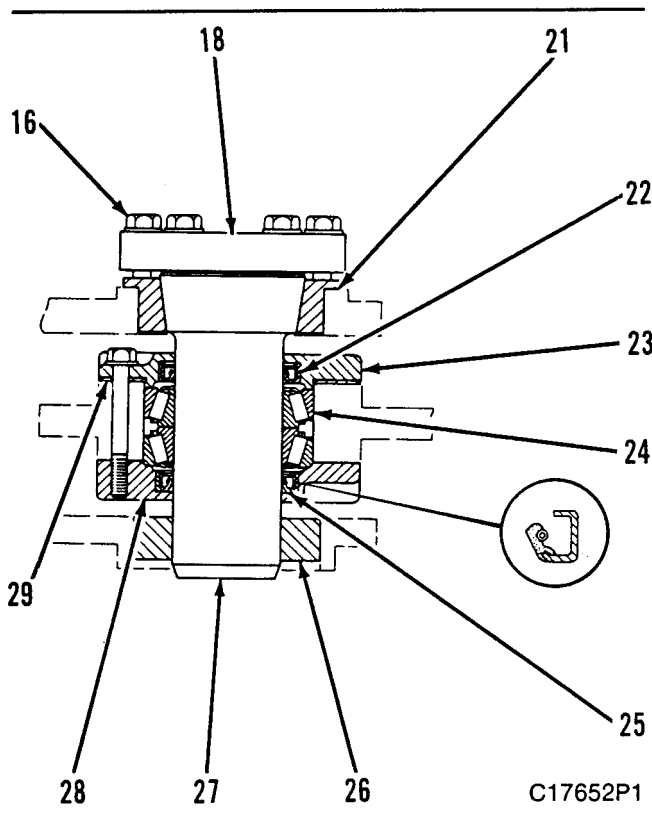
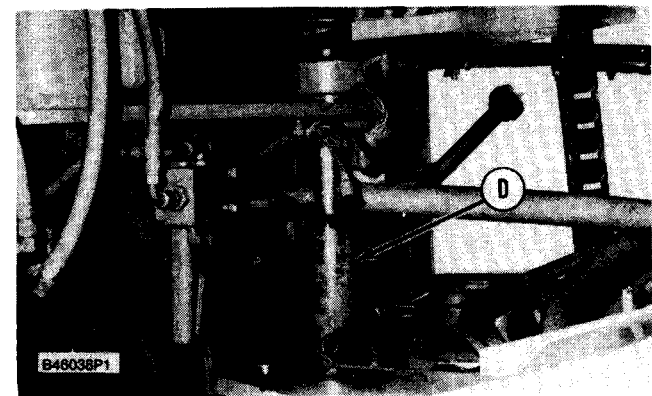

Upper Hitch

VEHICLE SYSTEMS

LOADER MAIN FRAMES Models 950 BNSCE and 950BSCE

21. Remove bolts (31) and (32) from the lower hitch of the front frame. Remove plate (30) and shims (33).

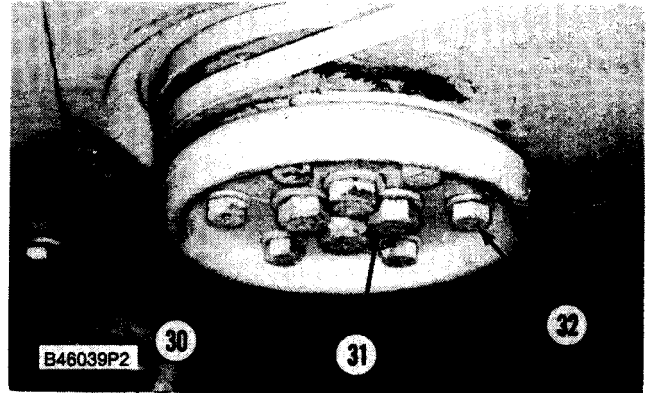

22. If necessary, use tooling (D) to remove pin (40) from the lower hitch assembly.

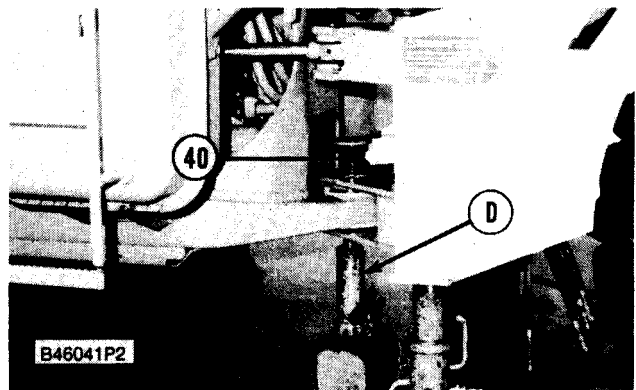

23. If necessary, use tooling (E) to remove spacer (34) from the lower hitch.

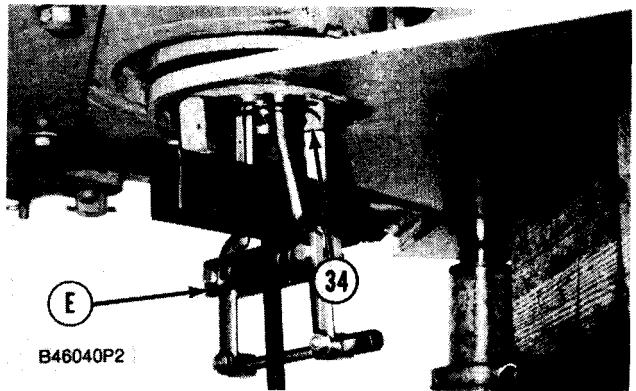

24. Remove pin (45) and pin (44). Make a separation of steering frame lock link (46).

NOTE: Make sure floor jack (13) stays in position when the rear frame is moved.

25. Remove tooling (B) and the blocks from the rear tires on the rear frame. Carefully pull rear frame (48) from front frame (47) with a lift truck and hoist.

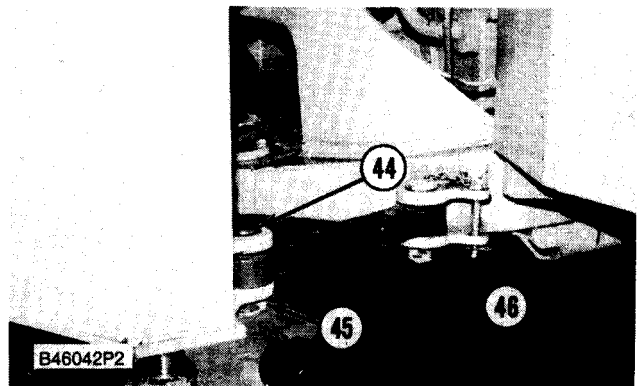
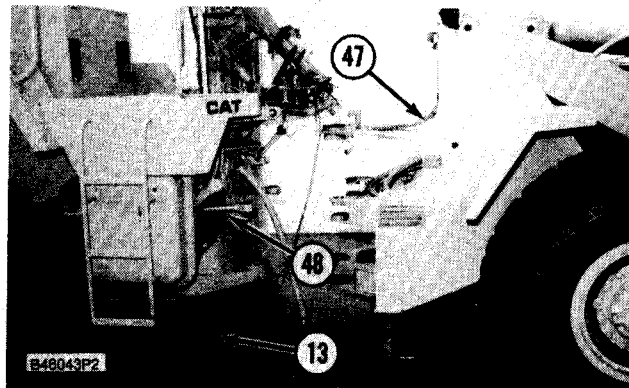

LOADER MAIN FRAMES

Models 950 BNSCE and 950BSCE

26. Remove spacer (41), bolts (38), and two bearing caps (42) and (35) from the lower hitch on the rear frame.

27. Carefully remove shims (37) from the lower hitch of the rear frame.

28. Remove lip type seals (39) and (43) from caps (42) and (35).

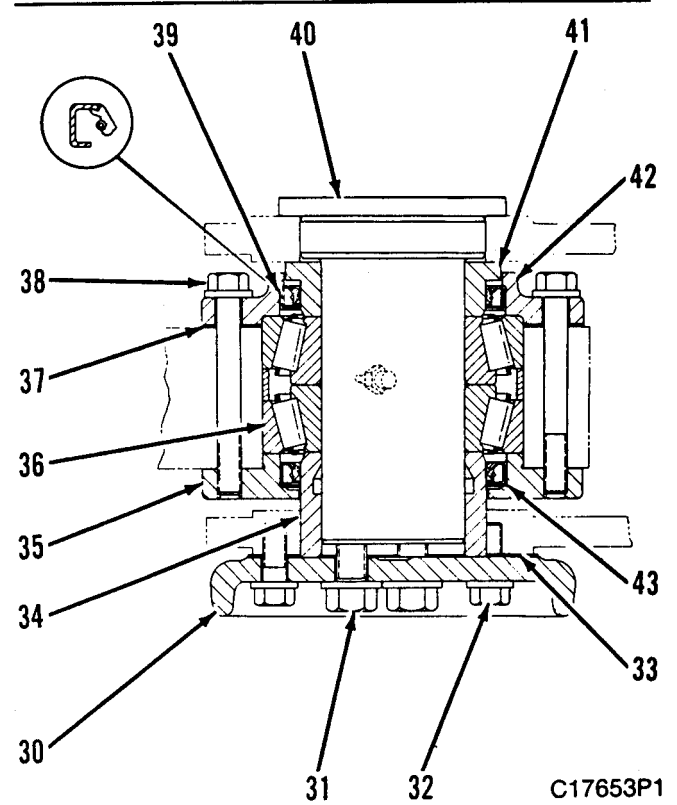

Lower Hitch

29. Put tooling (F) in position as shown, and remove bearing (36) from the lower hitch on the rear frame.

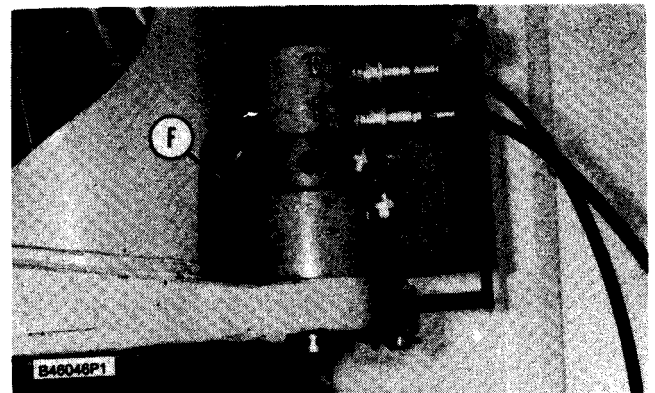

VEHICLE SYSTEMS

LOADER MAIN FRAMES Models 950 BNSCE and 950BSCE

30. Remove the bolts that hold cap (23). In the upper hitch on the front frame. Remove cap (23), shims (29), and cap (28).

31. Remove lip type seals (22) and (25) from caps (23) and (28).

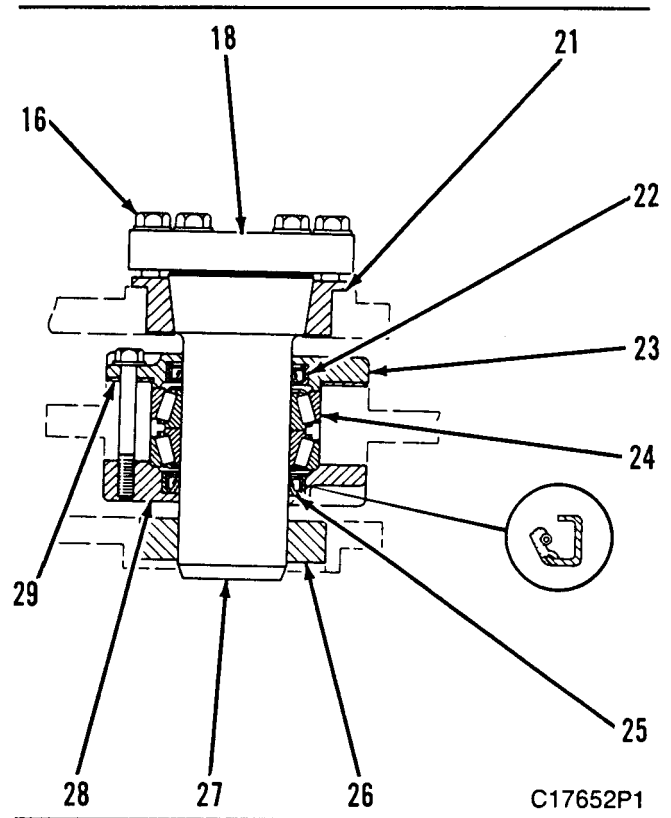

Upper Hitch

32. Use tooling (G) to remove bearing (24) from the upper hitch on the front frame.

33. Use tooling (G) to remove bearing (26) from the upper hitch on the rear frame.

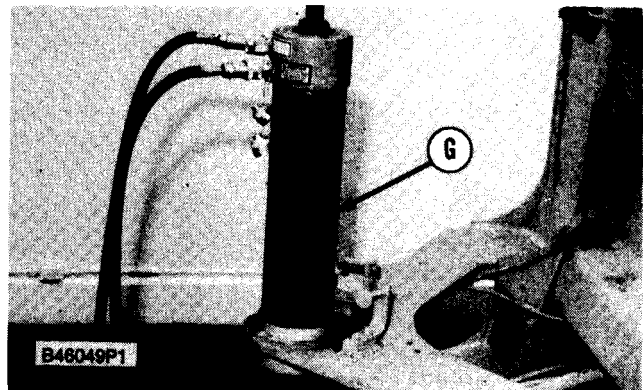

LOADER MAIN FRAMES Models 950 BNSCE and 950BSCE

Connection Of Loader Main Frames 7051-029

Tools Needed		A	B	C	G	J
6V3170	Hydraulic Puller				1	
5P7288	Adapter				1	
1P1841	Plate				1	
5P3100	Pump Group (or electric)	2			1	
1P5558	Stud, 1 1/4 in.				1	
1P544	Nut				1	
4K684	Washer				1	
1P520	Driver Group					1
6V2157	Link Bracket			2		
8S7615	Pin	2	2			
8S7640	Stand		2			
8S7611	Tube		2			
8S7610	Base Assembly	1				
8S7650	Cylinder	2				

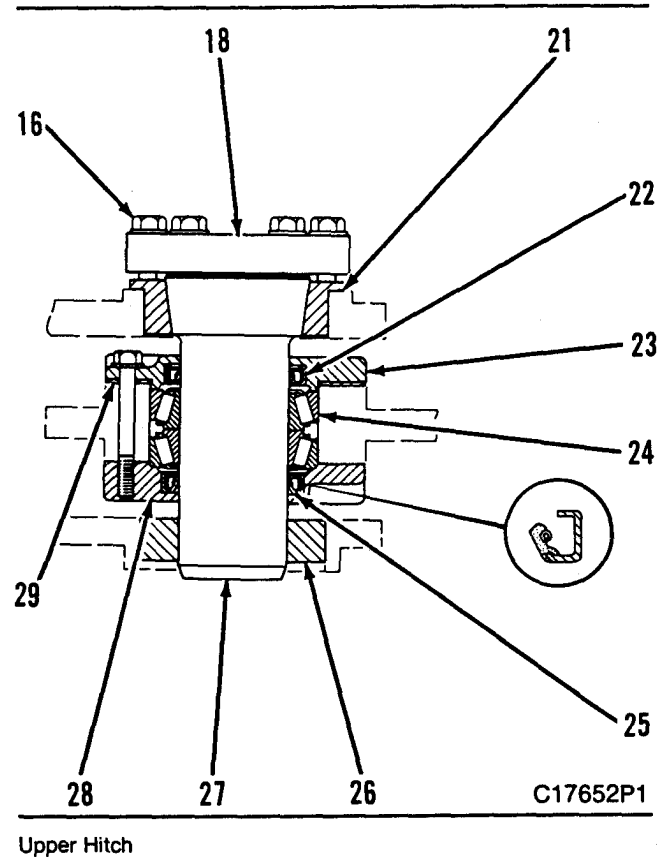

1. Coat the bores of the upper hitch group with 5P0960 Molybdenum Grease.

2. Install bearing (26) in the upper hitch of the rear frame with tooling (G). Install bearing (26) so that the bearing face is even with the inside surface on the upper hitch of the rear frame.

3. Lubricate the sealing lip of seals (22) and (25) lightly. Install lip type seals (22) and (25) with tooling (J) in caps (23) and (28). Install both seals with the seal lips facing upward.

4. Install three of the bolts that hold cap (23) equally spaced around cap (28). Cool the bearing cups of bearing (24) down to -75.5°C ($-1\ 67.9^{\circ}\text{F}$), and install the lower cup. Drive the cup down to insure contact with cap (28).

5. Lubricate the bearing cones with oil and install them. Install the cooled upper bearing cup, and drive it down to insure light contact pressure on the cones.

6. Install shims (29), cap (23) with three bolts and tighten. Install a torquing bolt assembly and tighten.

7. Apply a torque wrench to the torquing bolt and read the torque necessary to rotate the cones of bearing (24). If the torque is within a range of 2.3 N.m (20.4 lb. in.) to 13.6 N.m (120 lb. in.), install the remaining bolts in cap (23) and tighten. If the torque is less than 2.3 N.m (15.6 lb. in.) or greater than 13.6 N.m (120 lb. in.), remove or add shims (29) to obtain the correct rotating torque.

VEHICLE SYSTEMS

LOADER MAIN FRAMES Models 950 BNSCE and 950BSCE

8. Coat the bores of the lower hitch group with 5P0960 Molybdenum Grease.

9. Lubricate the sealing lip of seals (39) and (43) lightly. Install lip type seals (39) and (43) with tooling (J) in caps (42) and (35). Install both seals with the seal lips facing downward.

10. Install three of bolts (38) equally spaced around cap (35). Cool the bearing cups of bearing (36) down to -75.5°C (-106.1°F), and install the lower cup. Drive the cup down to insure contact with cap (35).

11. Lubricate the bearing cones with oil and install them. Install the cooled upper bearing, and drive it down to insure light contact pressure on the cones.

12. Install shims (37), cap (42) with three bolts and tighten. Install a torquing bolt assembly and tighten.

13. Apply a torque wrench to the torquing bolt and read the torque necessary to rotate the cones of bearing (36). If the torque is within a range of 1.1 N.m (9.7 lb. in.) to 5.6 N.m (50 lb. in.) install the remaining bolts (38) and tighten. If the torque is less than 1.1 N.m (9.7 lb. in.) or greater than 5.6 N.m (50 lb. in.) remove or add shims (37) to obtain the correct rotating torque.

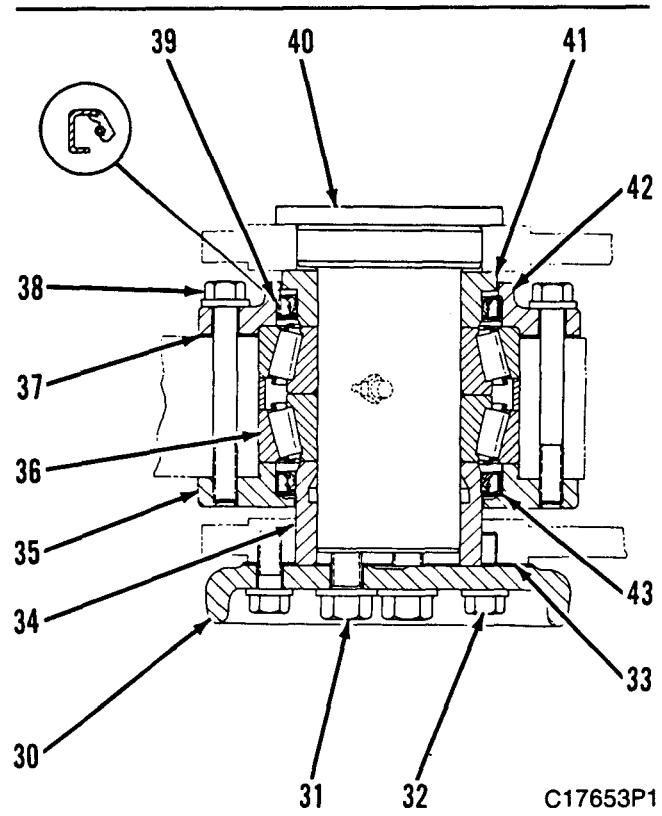

Lower Hitch

WARNING

Make sure floor jack (13) and the hoist are moved with rear frame (48).

14. Remove the blocks in front of the rear wheels and tooling (B) from the rear of the rear frame.

15. Use a lift truck and a hoist to connect rear frame (48) to front frame (47).

16. Connect steering frame lock link (46) to the front frame with pin (44) and pin (45).

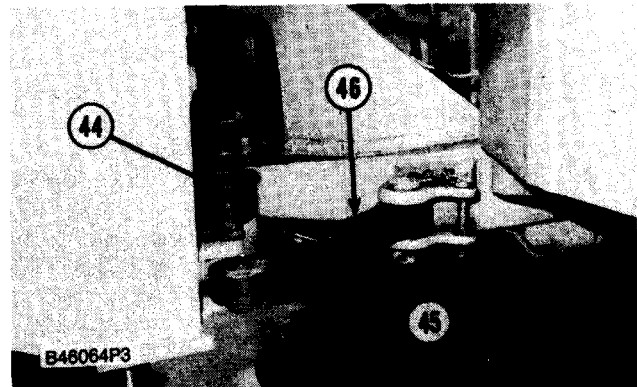
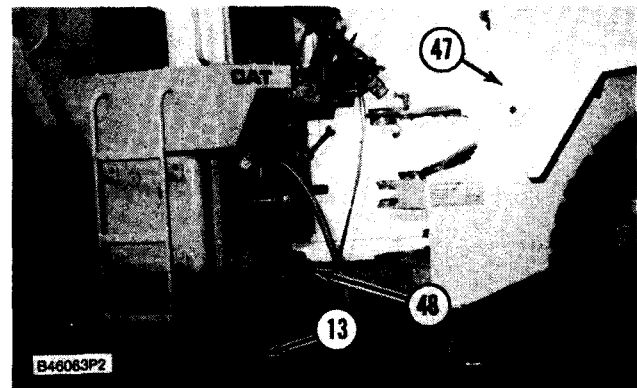

LOADER MAIN FRAMES Models 950 BNSCE and 950BSCE

17. Install collar (21) and pin (27) in the upper hitch assembly.

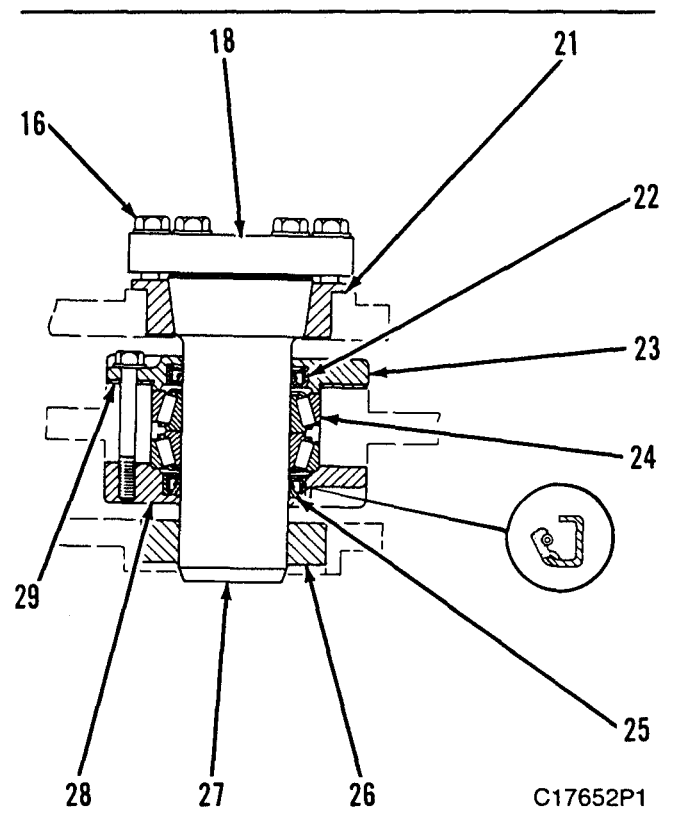

Upper Hitch

18. Install cover (18), and washers and bolts (16). Tighten two diagonally opposite bolts an equal amount. Tighten the two remaining bolts an equal amount. Repeat procedure until all the bolts are tight.

19. Position hoses (20) on cover (18), and install washers and bolts (17) that hold the hose clips.

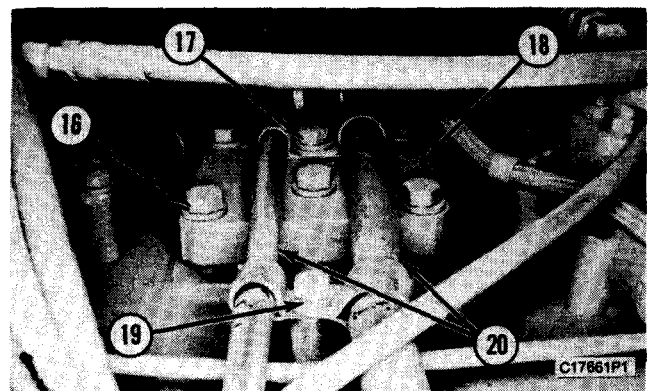

LOADER MAIN FRAMES Models 950 BNSCE and 950BSCE

20. Install pin (40) in the lower hitch assembly. Install spacer (34).

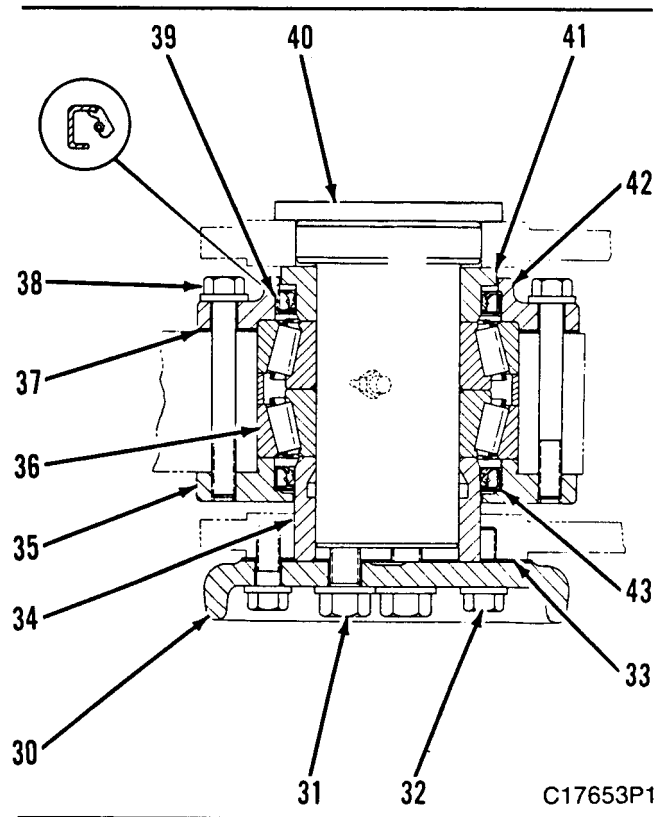

Lower Hitch

21. Position shims (33) and plate (30). Install two of bolts (31), 180° apart. If the holes in cap (30) and the holes in the frame are not in alignment, use two 5/8" - 11 NC guide bolts to turn cap (30) and the pin as shown. Tighten the bolts to 68 N•m (50 lb.ft.).

22. Measure the gap with a feeler gauge 360° around between the lower front frame and plate (30). Install shims (33) needed of minimum measurement minus 0.25 mm (.010 in.) under plate (30).

23. Install all of bolts (31) and (32), and tighten them.

24. Disconnect the hoist and tooling (C), and install bolts (15).

25. Make an alignment of the steering cylinders to the front frame, Install pins (30). Install the spacers, washers and bolts (11) that hold the pins in place.

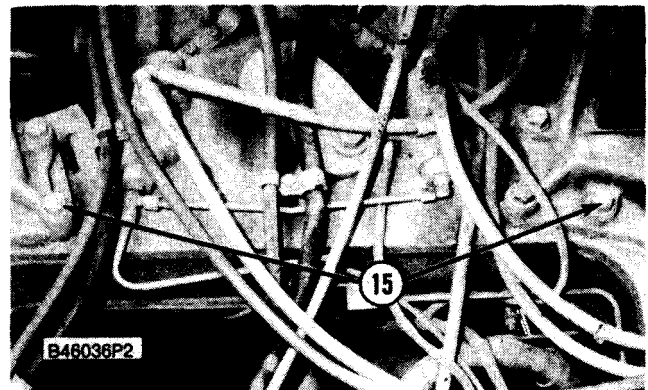
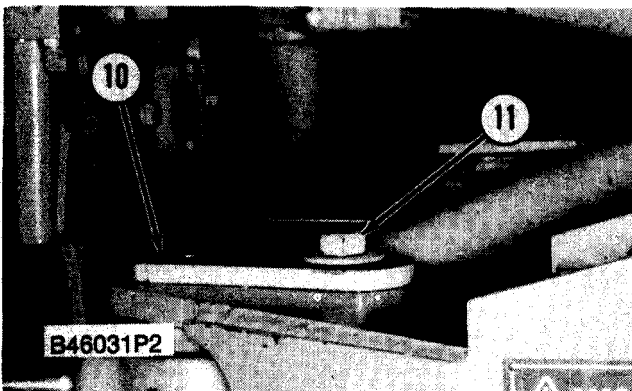
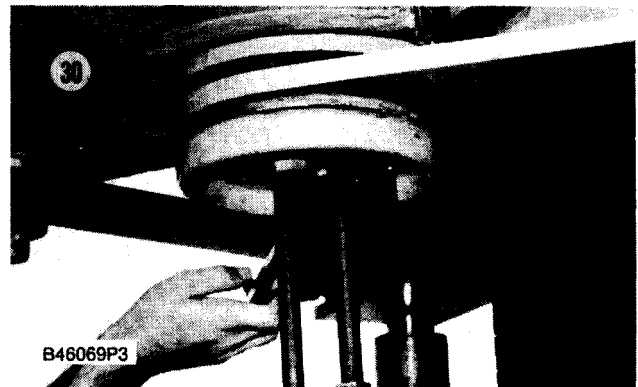

LOADER MAIN FRAMES

Models 950 BNSCE and 950BSCE

26. Position hose assembly (8) on the loader control valve and install bolts (9).

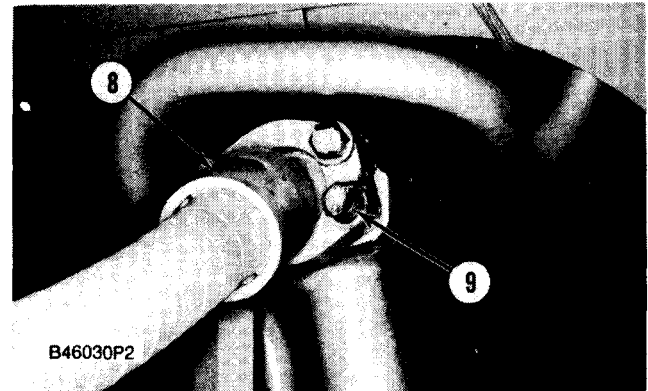

27. Position hydraulic oil line (7) on the rear frame and install the bolts that hold it.

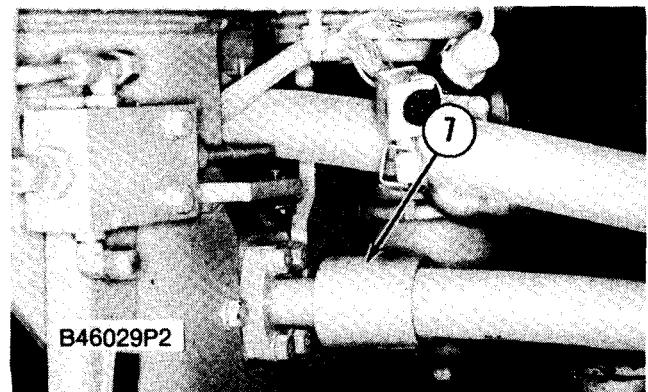

28. Position the brackets that hold the pilot control valve lines and install bolt (6).

29. Connect hydraulic oil line (5) to the selector and pressure control valve.

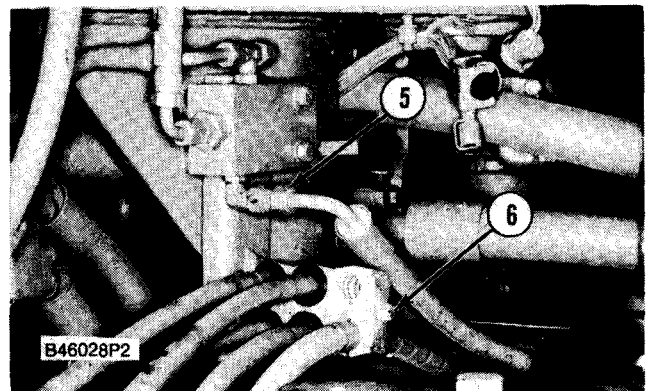

30. Connect pilot oil lines (4) from the pilot valve.

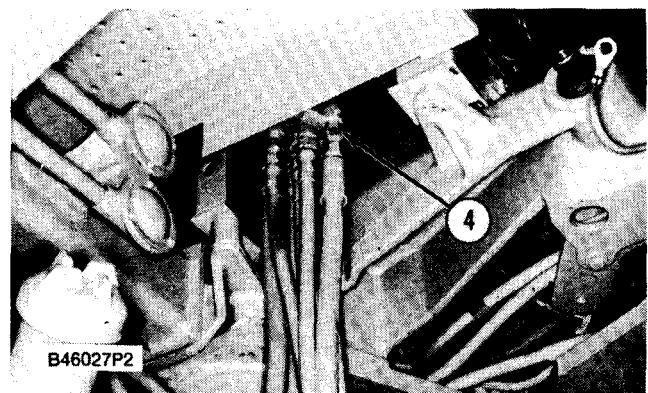

LOADER MAIN FRAMES

Models 950 BNSCE and 950BSCE

31. Connect the clip on the rear frame with bolt (3).
Connect wire harnesses (2).

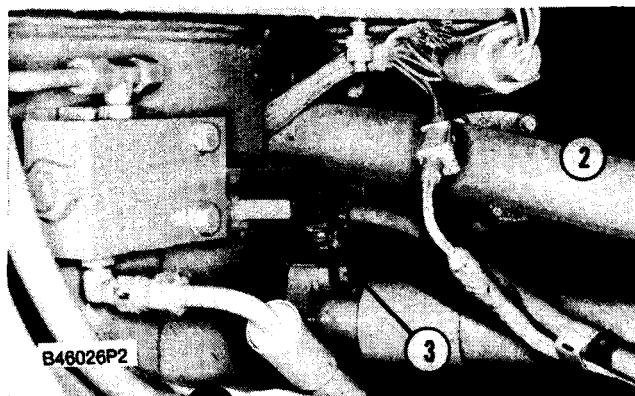

32. Position clip (1) on the front frame and install the bolt that holds the clip.

33. Remove all of the tooling and blocking.

End By:

- a. install transmission neutralizer group
- b. install center drive shaft
- c. install cab and platform
- d. separation of steering frame lock link

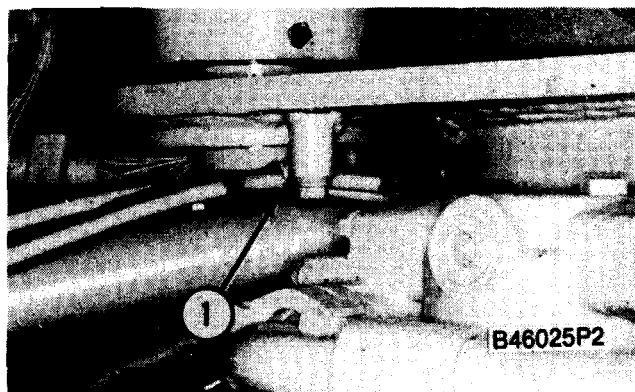

SEAT

REMOVE SEAT

7312-11

1. Remove four bolts (1) from the seat platform.
2. Fasten a hoist to the seat or use two persons and remove seat (2) from the cab. The weight of the seat is 52 kg (115 lb.).

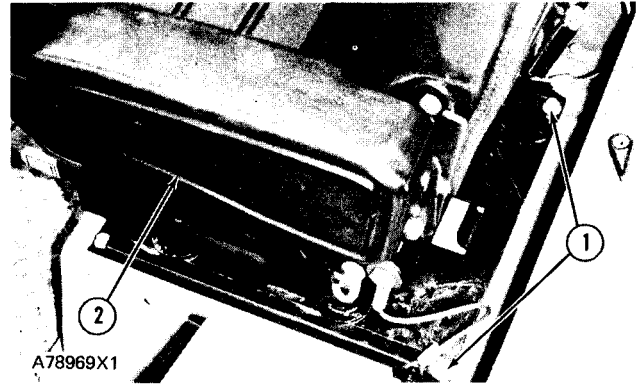

I N S T A L L S E A T 7 3 1 2 - 1 2

1. Fasten a hoist to the seat or use two persons to put seat (1) in position in the cab.
2. Install the four bolts that hold the seat to the platform.



DISASSEMBLE SEAT

7312-15

1. Disconnect springs (1) (one on each side of the seat) from the bar.
2. Put the back cushion assembly in position as shown. Remove bolts (3) (one from each side of the cushion assembly) and loosen screws (4).

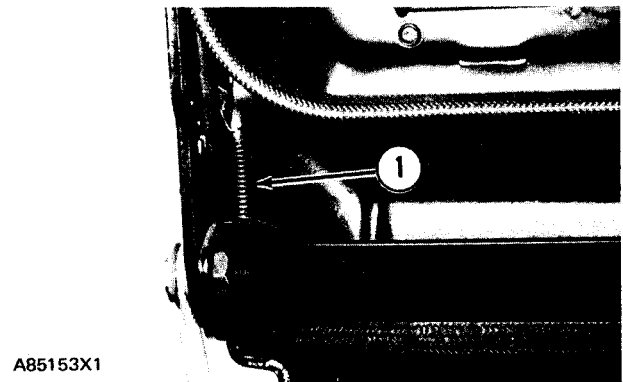

3. Remove cushion assembly (2) and plate assemblies as a unit from the bracket assemblies.

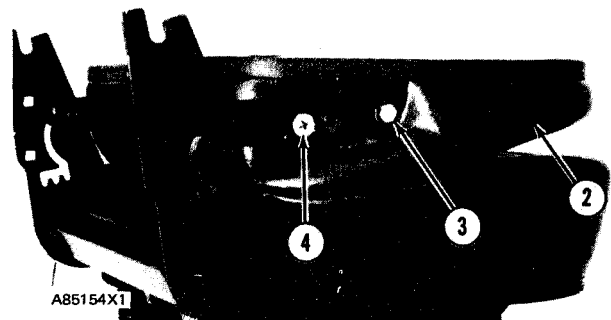

SEAT

4. Remove screws (4) (one from each plate assembly). Remove plate assemblies (5).

5. Remove springs (1) from the plate assemblies.

6. Remove bolts (7) (one from each side of the cushion assembly). Remove cushion assembly (6) and two spacers from the bracket assembly.

7. Remove springs (8) (one from each side) from the cushion assembly.

8. Remove pin (9). Slide latch assembly (11) toward the center of the cushion assembly approximately 25.4 mm (1 in.). Remove shaft (10) from the cushion assembly. Remove the latch assembly from the shaft.

9. Remove bolt (13), washer and nut from each bracket assembly. Remove bar (12).

10. Remove the bolts that hold the cables to the adjuster group. Remove cables (14).

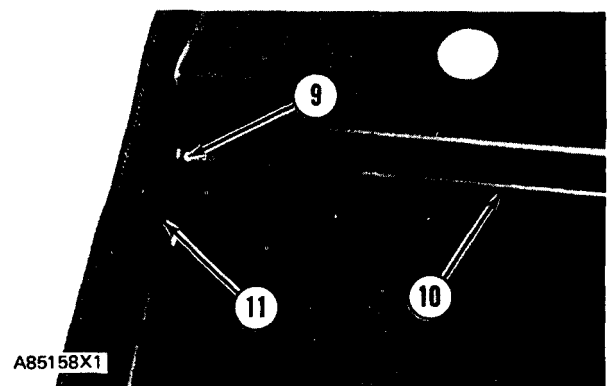
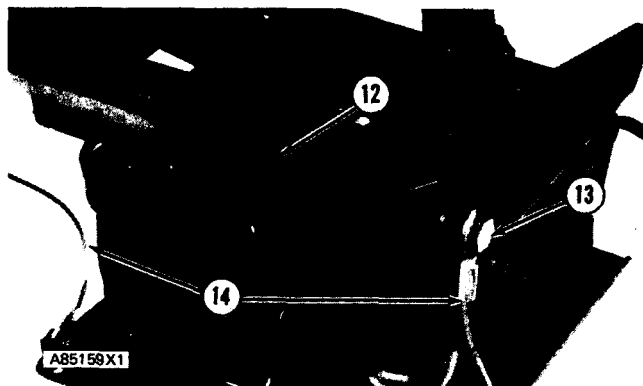
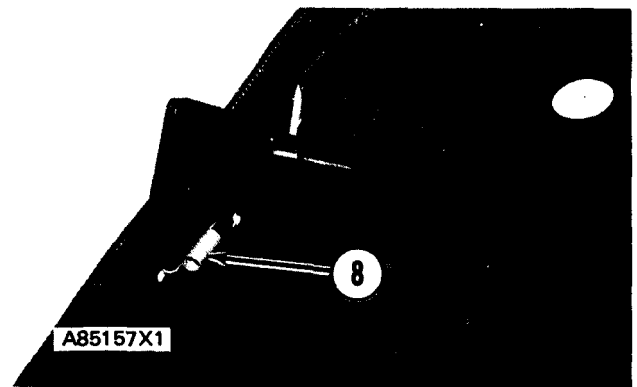
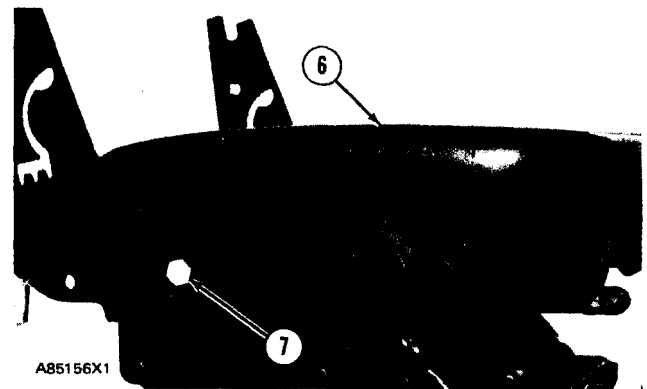
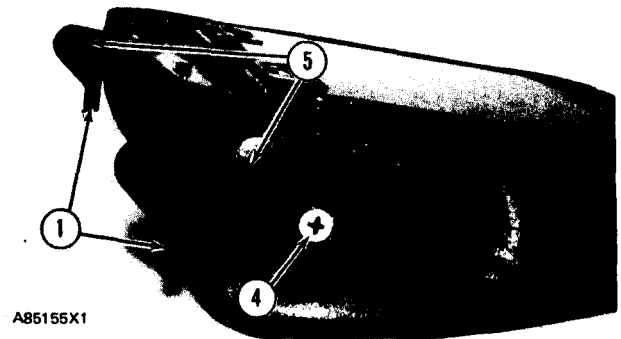

SEAT

11. Remove locknuts and washers (16). Remove bracket assemblies (15) from the suspension group.

NOTE: Earlier models have retainers in place of the locknuts and washers. It is necessary to destroy the retainers to remove them.

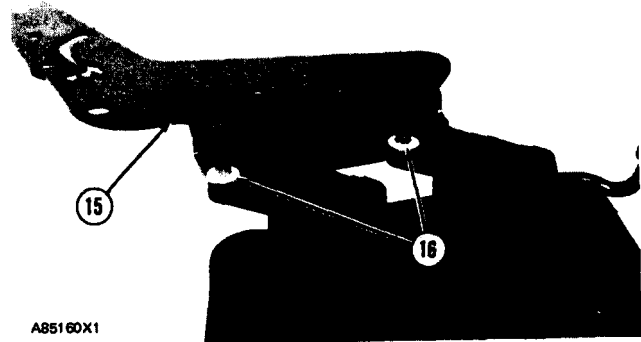

12. Remove pin (17) from the latch assembly.

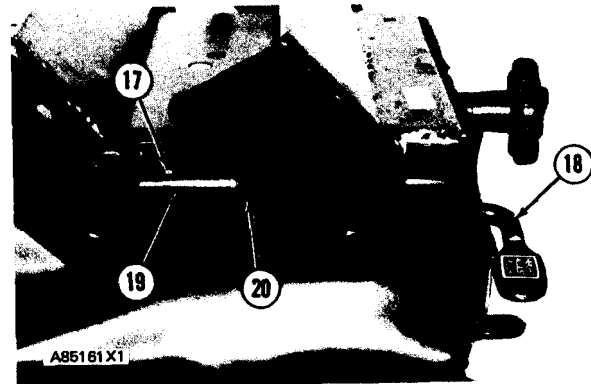

13. Remove lever (18). Remove latch assembly (19) and spring (20).

14. If necessary, because of wear or damage, remove cap (21) from the lever.

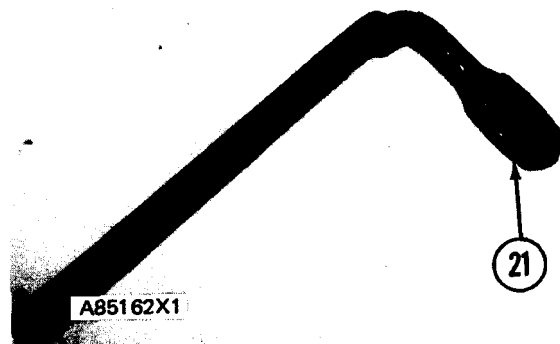

WARNING

Serious personal injury can be the result if spring force is not carefully released when springs are disconnected from the housing assembly.

15. Use a screwdriver to disconnect springs (22) from the housing assembly.

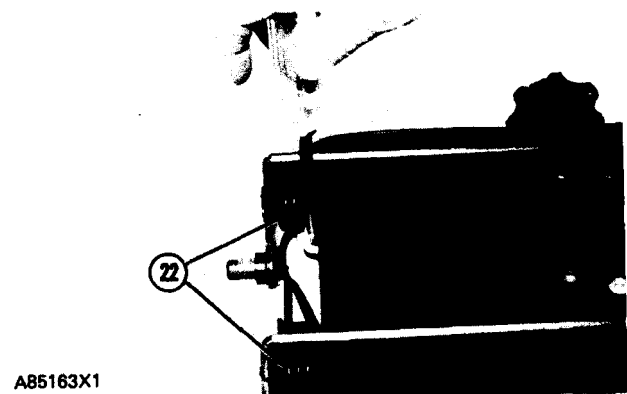

SEAT

16. Remove bolts (24) and lockwashers from each side of the link assembly. Remove link assembly (23) and springs (22) from the suspension group.

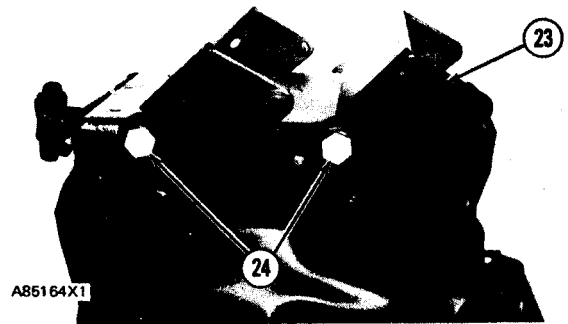

17. Remove retainers (25). Remove links (26) from the link assembly.
NOTE: It is necessary to destroy retainers (25) to remove them.

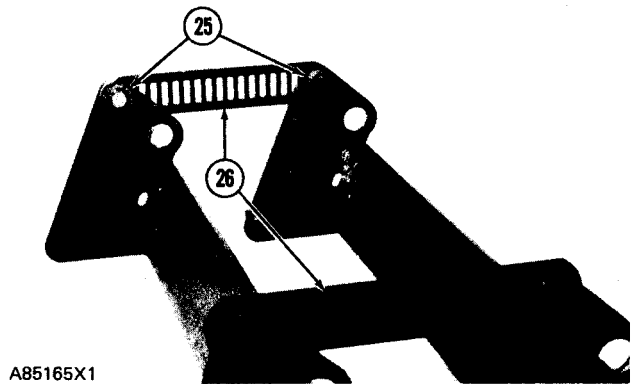

18. Remove pin (27). Remove knob assembly (28) and spacer (29) from the shaft.

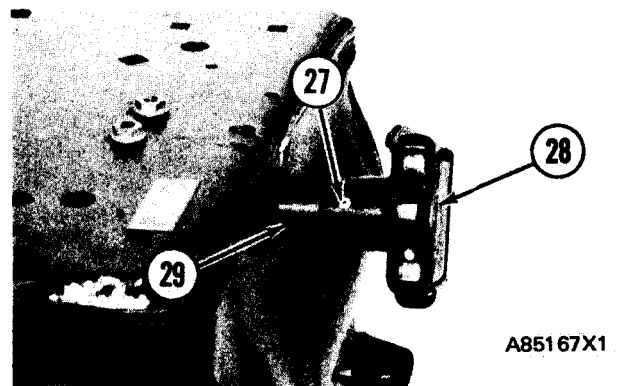

19. Use a screwdriver to remove fasteners (30) from the suspension group. Remove boot (31).

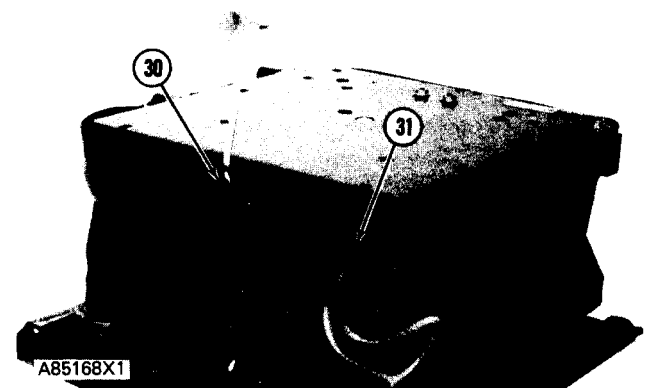

20. Remove indicator (32) and pin (33).

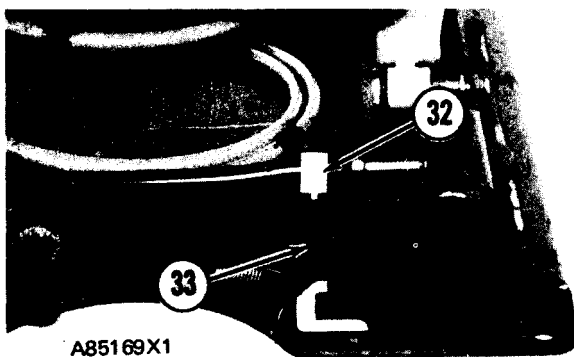

SEAT

WARNING

Housing assembly is under spring force. Put a downward force on the housing assembly and remove the shafts. Release the housing assembly slowly until the spring force on it is released.

21. Remove nuts (34). Remove shafts (35).

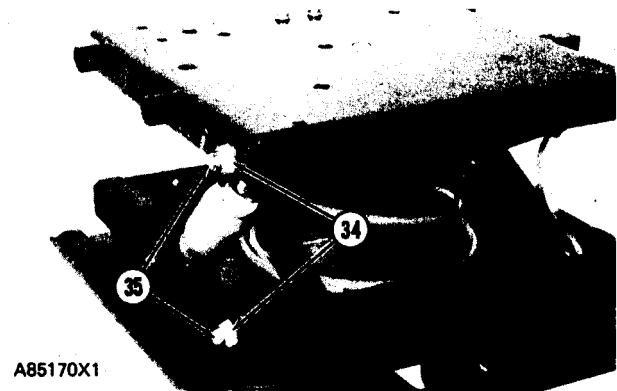

22. Remove four bearings (36) from the arm assembly.

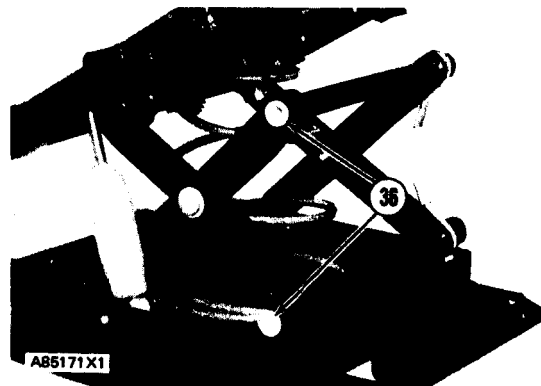

23. Remove sleeves (38) and cable (37) from the arm assembly.

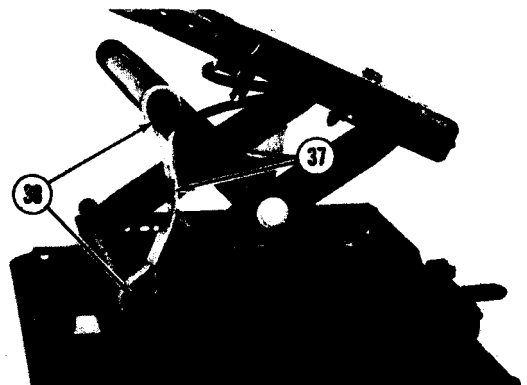

24. Remove gear assembly (39) and washer from the housing assembly.

25. Remove pin (40) from the gear assembly. Remove plate assembly (41).

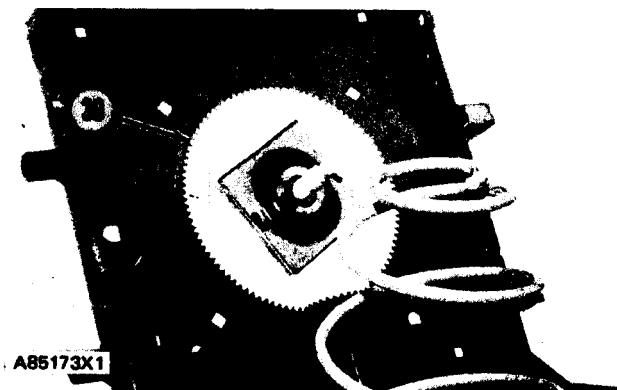
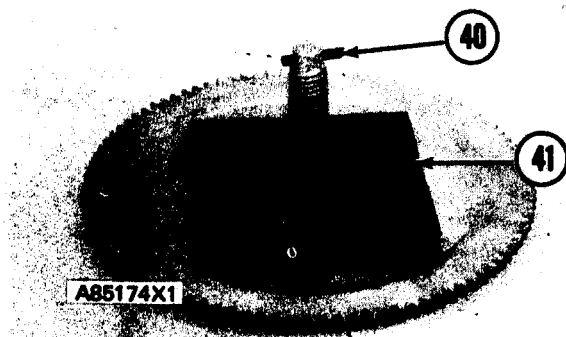

OPERATOR'S STATION

SEAT

26. Remove gear assembly (42) from the housing assembly.

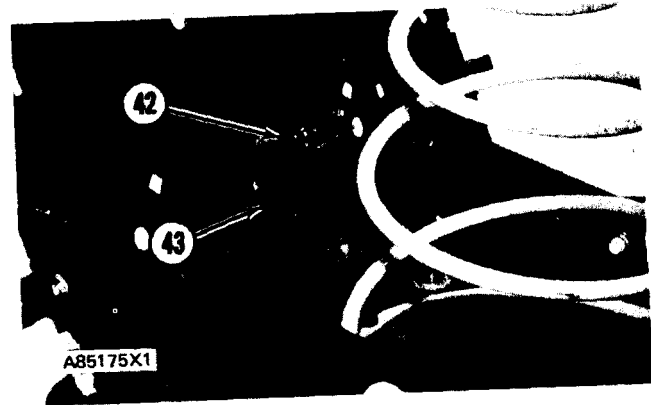

27. Remove bolts and nuts (44). Remove bracket (43).

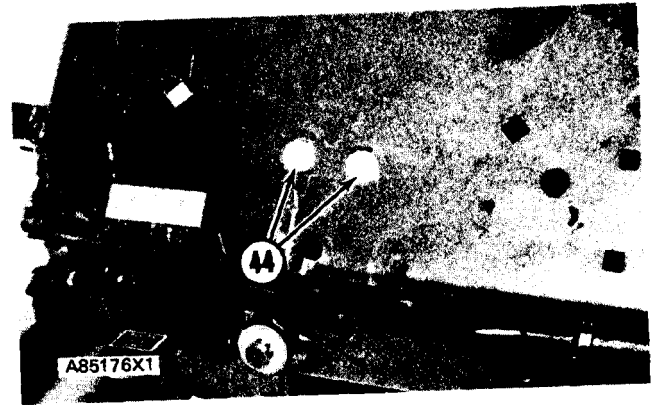

28. Remove housing assembly (45) and two blocks from the arm assembly.

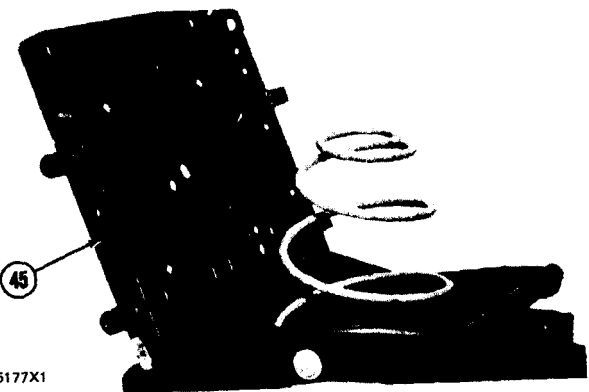

29. Remove arm assembly (46) and two blocks from the adjuster group.

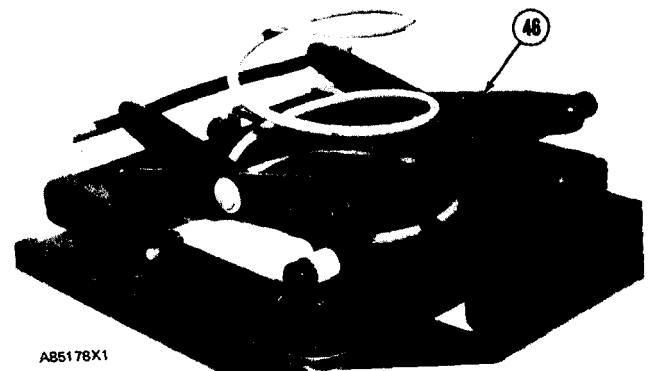

30. Remove spring (47).

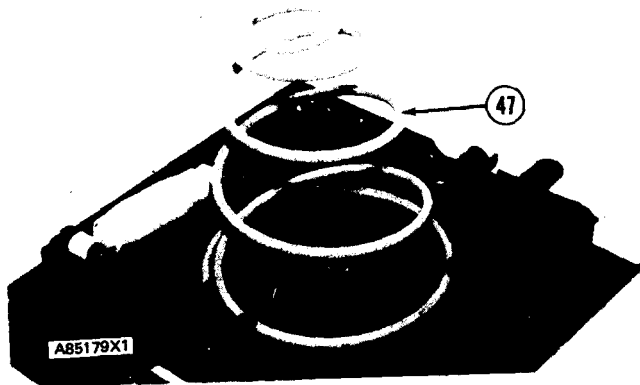

SEAT

31. Remove bolt and nut (49). Remove shock absorber (48).

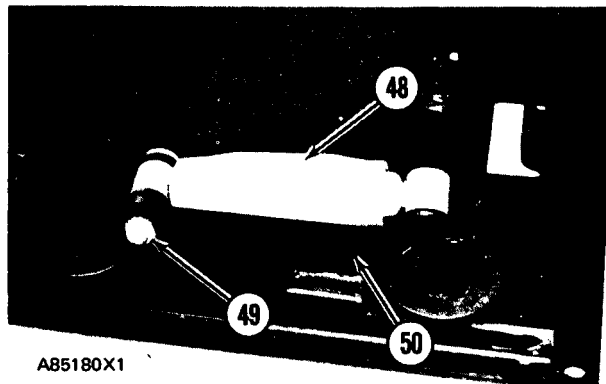

32. Remove the bearings from each end of the shock absorber.

33. Remove bolt (51) from the bottom of the plate. Remove housing assembly (50) from the plate.

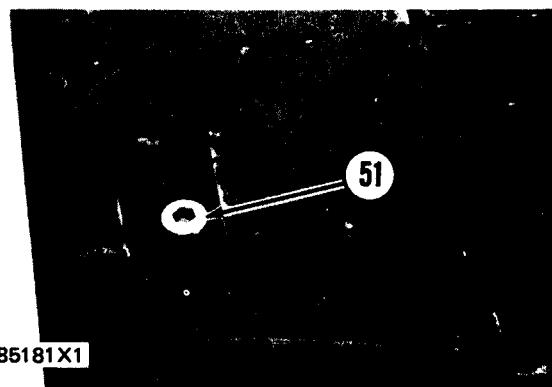

34. Remove retainers (55). Remove roller assemblies (56).

NOTE It is necessary to destroy retainers (55) to remove them.

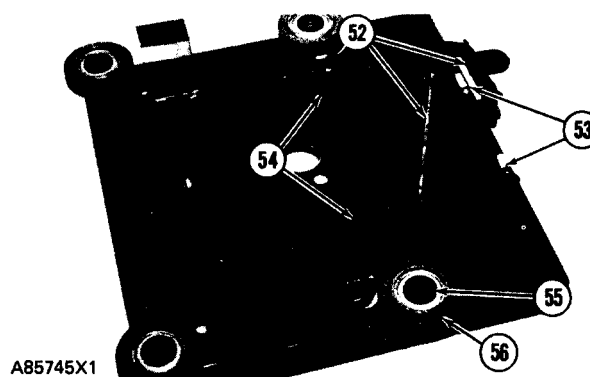

35. Remove pad (57) from the housing assembly.

36. Remove retainers (59). Remove rods (52), springs (53), latch assemblies (54) and lever (58).

NOTE It is necessary to destroy retainers (59) to remove them.

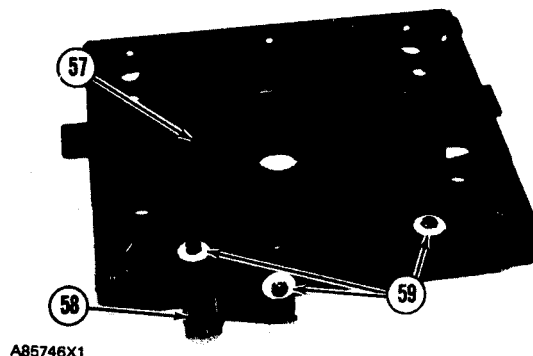

SEAT

ASSEMBLE SEAT

7312-16

Tools Needed		A
FT1421	Seat Spring Installer	1

1. Install lever (3), latch assemblies (1), rods (2), and springs (4) on the housing. Install the retainers that hold the lever and latch assemblies to the housing. Use a piece of pipe with a 15.9 mm (.625 in.) inside diameter approximately 12.7 cm (5 in.) long to install the retainers.

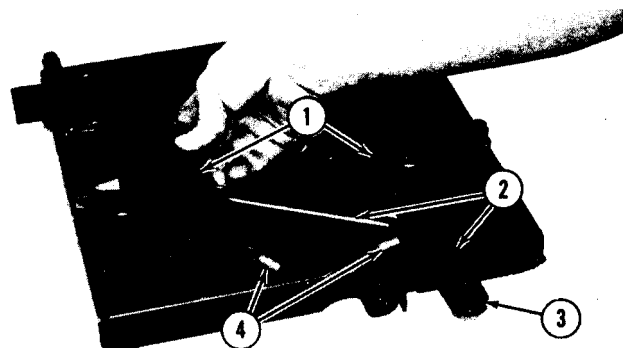

2. Put 5H2471 General Purpose Adhesive on the housing assembly and install pad (5).



3. Put roller assemblies (7) in position on the housing assembly.

NOTE: Make sure the swaged side (raised metal) (8) of the roller is away from the lower housing assembly.

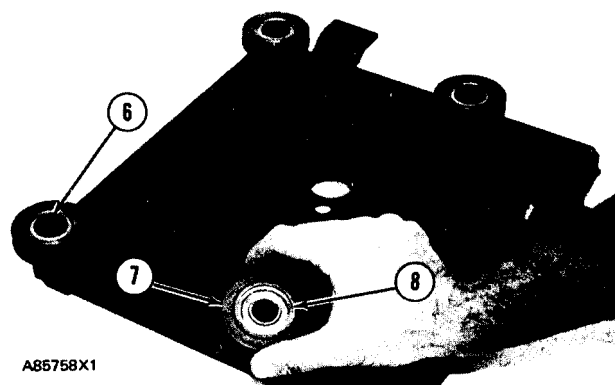

4. Install the retainers (6) that hold the roller assemblies. Use a piece of pipe with a 15.9 mm (.625 in.) inside diameter approximately 12.7 cm (5 in.) long to install the retainers.

5. Put plate (9) in position on the housing assembly (10). Install the bolt that holds the housing assembly on the plate. Tighten the bolt to a torque of $70 \pm 7 \text{ N}\cdot\text{m}$ ($50 \pm 5 \text{ lb. ft.}$).

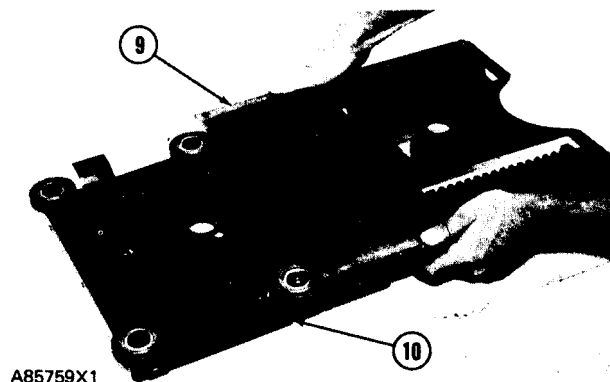

SEAT

- 6. Install bearings (13) in each end of the shock absorber.
- 7. Put shock absorber (11) in position in the housing assembly. Install bolt (12) and nut that hold it.
- 8. Install spring (14) in the housing assembly.

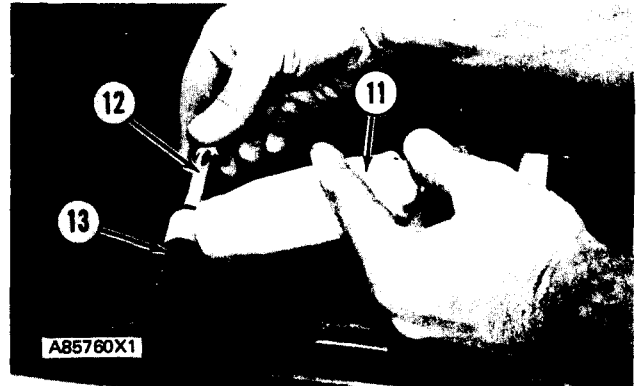

- 9. Install blocks (16) on each side of the arm assembly as shown.
- 10. Install arm assembly (15) in the housing assembly.

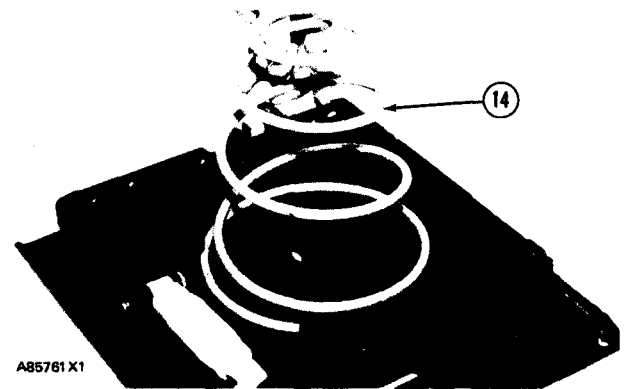

- 11. Install blocks (18) on each side of the arm assembly as shown.
- 12. Install upper housing assembly (17) on the arm assembly.
- 13. Install bracket (19) on the upper housing assembly.

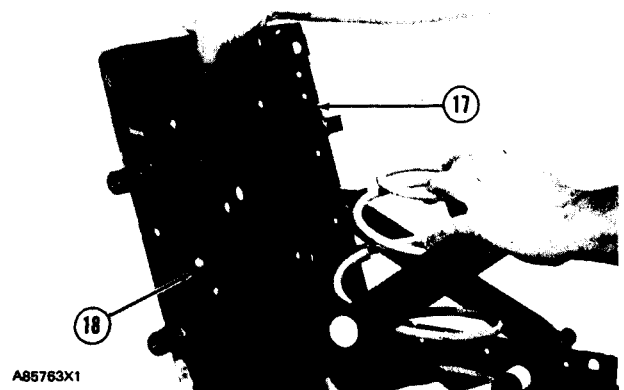
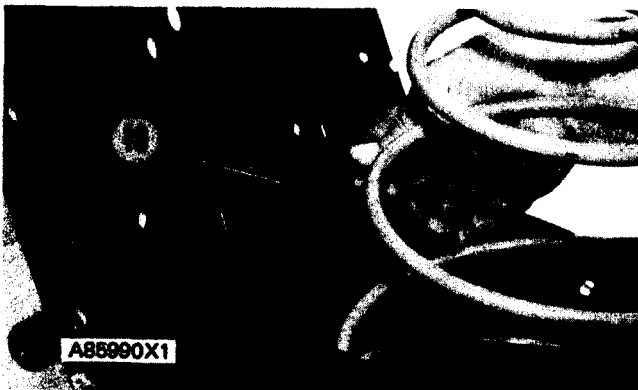
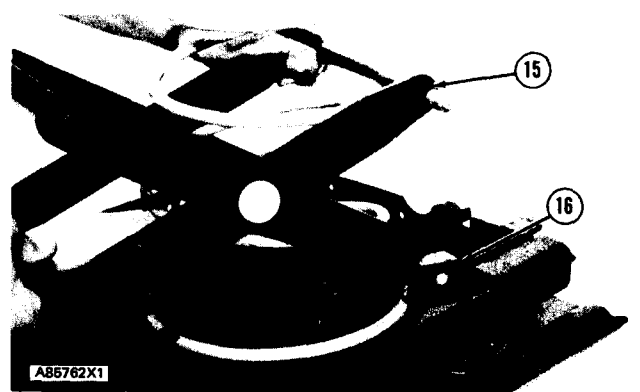

SEAT

14. Install gear assembly (20) in the bracket and housing assembly.



15. Install plate assembly (23) on the gear assembly. Install pin (22).

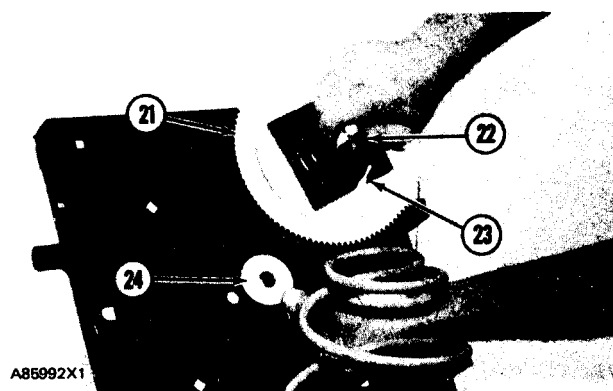

16. Install washer (24) and gear assembly (21) on the housing assembly.



17. Install sleeves (26) and cable (25) on the arm assembly.

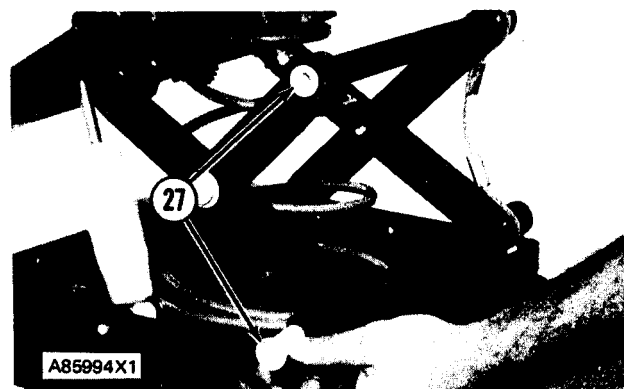

18. Install bearings (27) in each end of the arm assembly.

SEAT

19. Push down on the upper housing assembly and put the spring under compression. Put shock absorber (11) in position and install shafts (28) in the upper and lower housing assemblies. Install the nuts on the shafts.

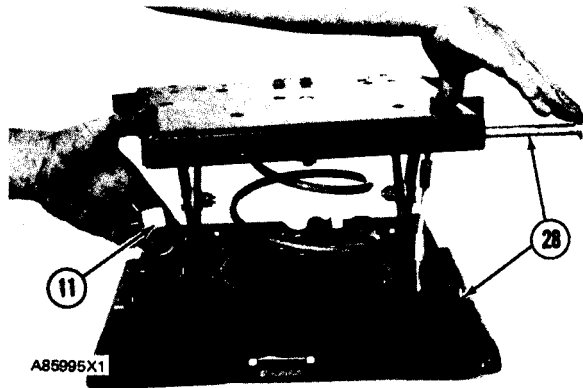

20. Install pin (30) in the housing assembly so that the distance between the end of the pin and the surface of the housing assembly is 12.7 mm (.5 in.).

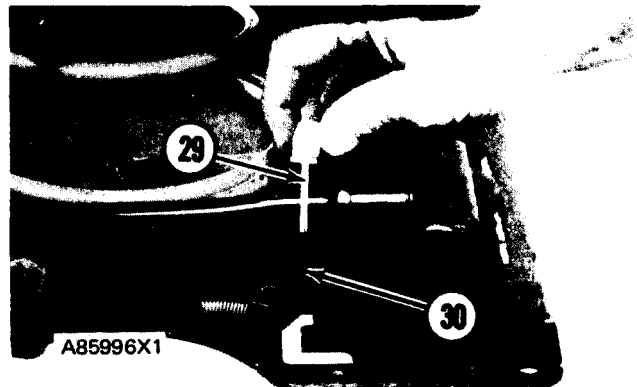

21. Install indicator (29) on the arm assembly.

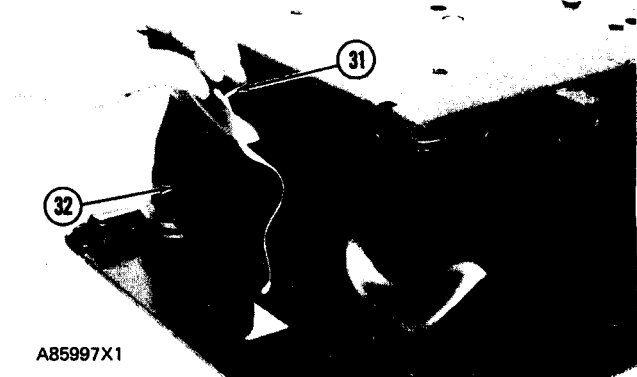

22. Put boot (32) in position on the suspension group and install fasteners (31) that hold it.

23. Install spacer (33) and knob assembly (34) on the gear assembly. Install the pin that holds the knob assembly.

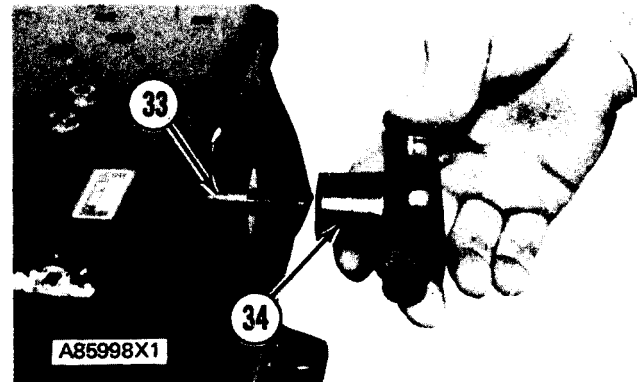

SEAT

24. Put springs (35) in position on the suspension group.

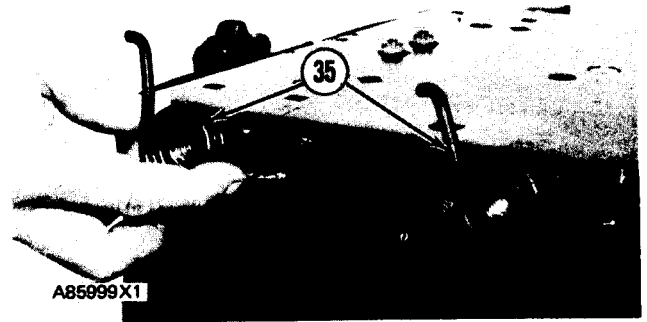

25. Install links (38) on each end of the link assemblies (36). Use a piece of pipe (37) with a 15.9 mm (.625 in.) inside diameter approximately 12.7 cm (5 in.) long to install the retainers on the links.

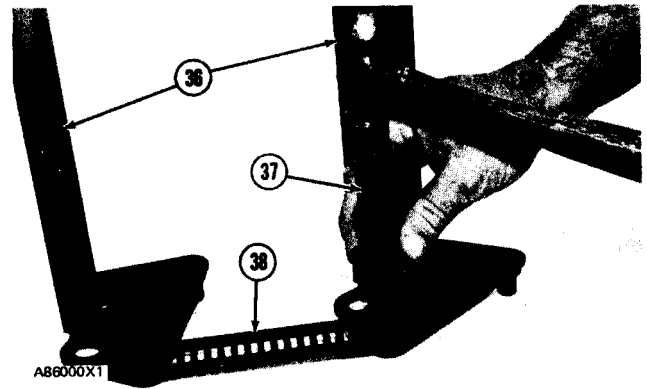

26. Put link assembly (39) in position on the suspension group. Install the bolts that hold it.

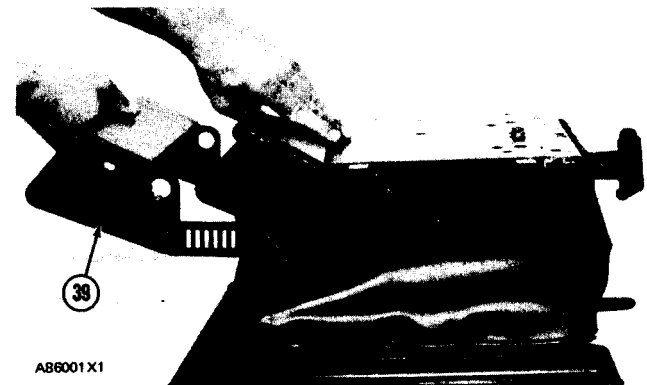

27. Use tool (A) to put springs (35) in their correct position in the upper housing assembly.

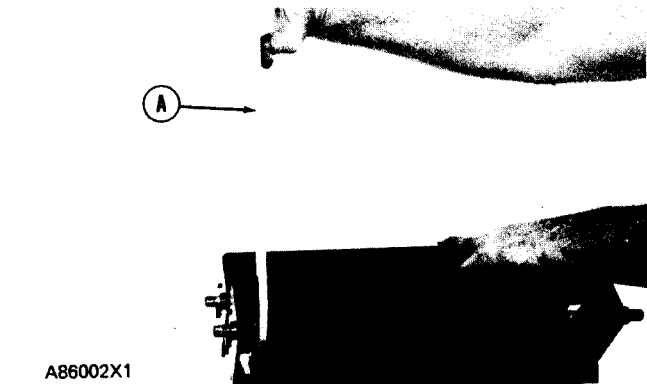

28. If cap (40) was removed from the lever (41). Put 5H2471 General Purpose Adhesive on the lever and install a new cap.

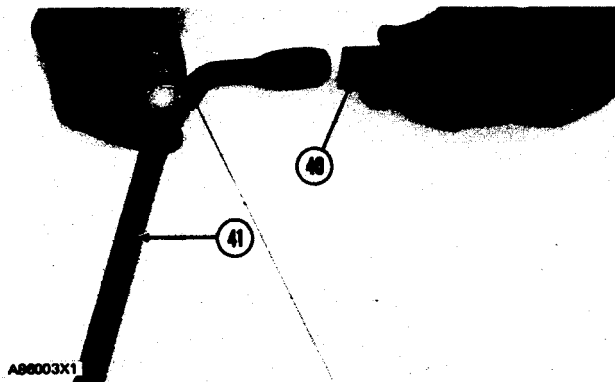

SEAT

29. Put latch assembly (43) and spring (42) in position on the suspension group. Install lever (41). Install the pin in the latch assembly and lever.

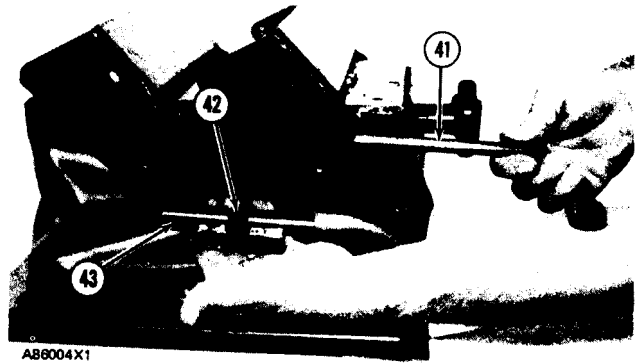

30. Put bracket assemblies (44) in position on the link assembly. Use a piece of pipe with a 15.9 mm (.625 in.) inside diameter approximately 12.7 cm (5 in.) long to install the retainers that hold the bracket assemblies.

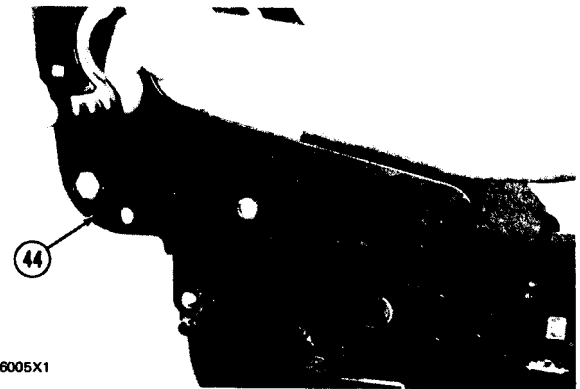

31. Put bar (45) in position between the bracket assemblies. Install spacers (46), cables (48), and bolts (47).

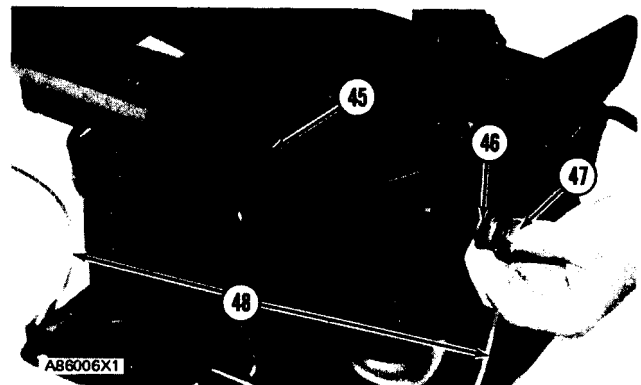

32. Connect the cables to the plate.
NOTE: After assembly the cables must make a curve toward the front of the seat as shown.

33. Put latch assembly (50) on the shaft. Install shaft (49) in the cushion assembly. Slide latch assembly into position on the shaft until the holes in the shaft and latch assembly are in alignment. Install the pin in the latch assembly and shaft.

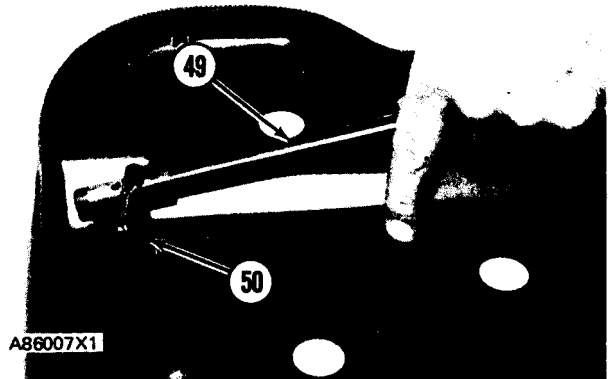

34. Install the springs on the latch assembly and cushion assembly.

SEAT

35. Put spacers (52) and seat cushion assembly (51) in position in the bracket assemblies.

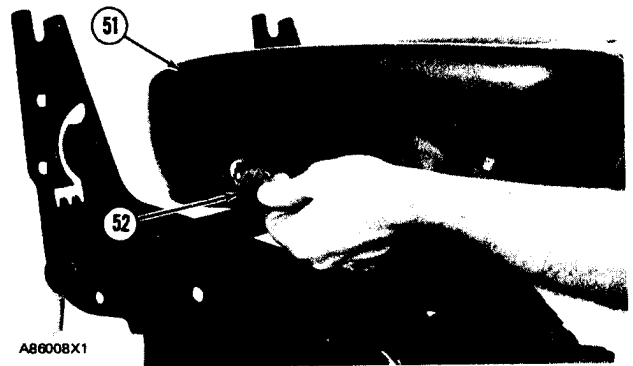

36. Install the bolts that hold the cushion assembly. Tighten the bolts to a torque of 27 N•m (20 lb. ft.), then turn the bolts ¼ turn counter-clockwise.

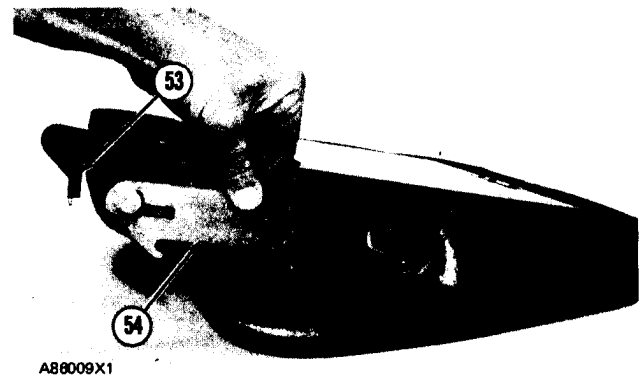

37. Install plate assemblies (54) on the back cushion assembly. Install the screws and locknuts that hold the plate assemblies but do not tighten.

38. Install springs (53) on the plate assemblies.

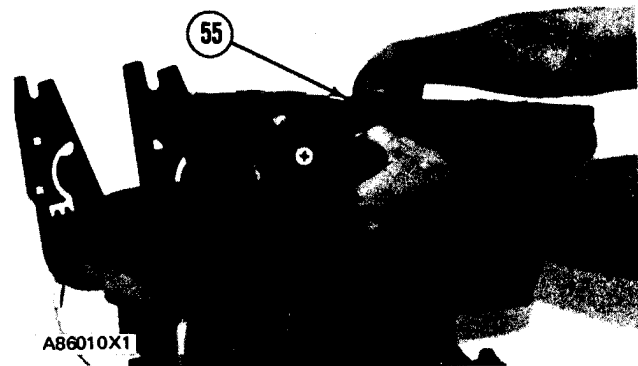

39. Install back cushion assembly (55) and plate assemblies on the bracket assemblies. Install the bolts in the plate assemblies and tighten the screws.

40. Put back cushion assembly in the "UP" position. Connect springs (53) to bar (45).
end by:
a) install seat

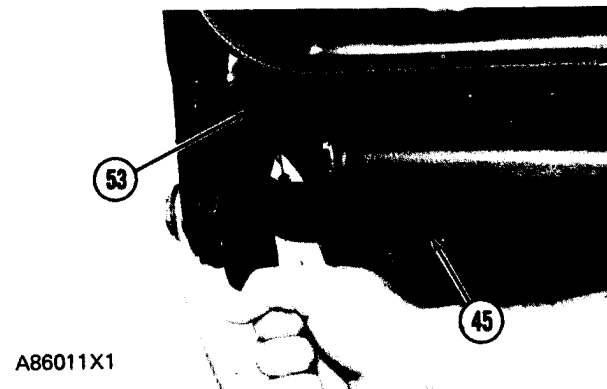

STEERING WHEEL

REMOVE STEERING WHEEL 4309-11

Tools Needed		A
1P70	Head	1
5F7345	Screw	1
266593	Bolt	2
4b4276	Washer	2

1. Remove three screws (1). Remove cover (2) from the steering wheel.

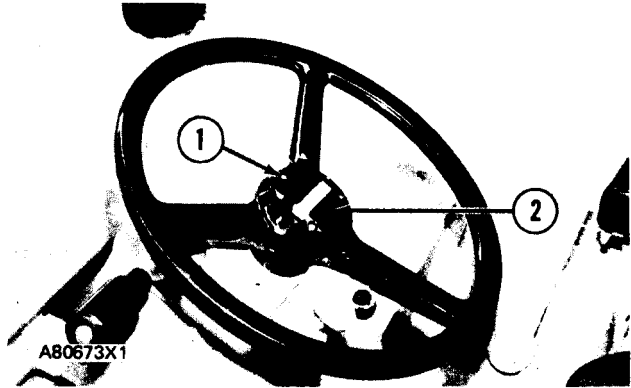

2. Remove nut (3) from the steering shaft.

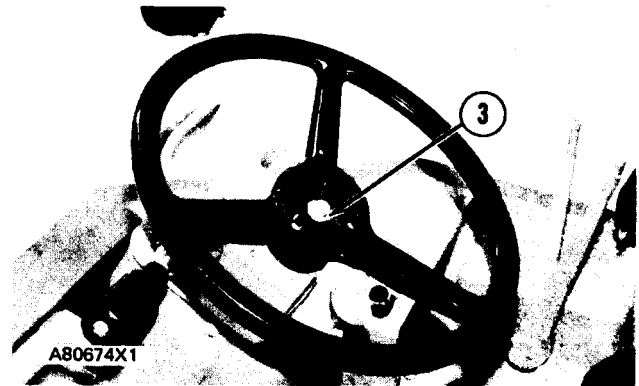

3. Install tooling (A) as shown and remove steering wheel (4).

INSTALL STEERING WHEEL 4309-12

1. Put steering wheel (2) in position on the steering shaft, Install nut (1) and tighten to a torque of $50 \pm 4 \text{ N}\cdot\text{m}$ ($37 \pm 3 \text{ lb. ft.}$). Put 5P960 Multipurpose Type Grease on the nut and steering shaft threads after assembly.

2. Install cover (3) on the steering wheel.

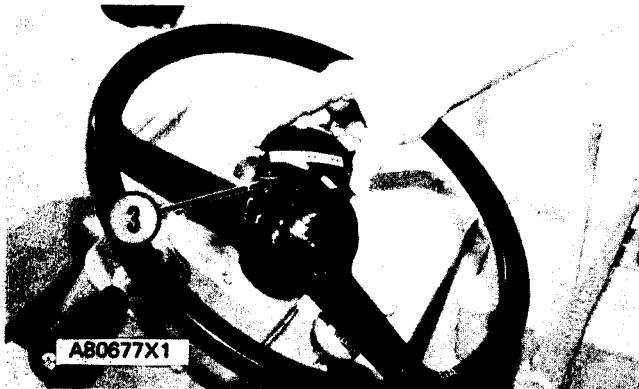
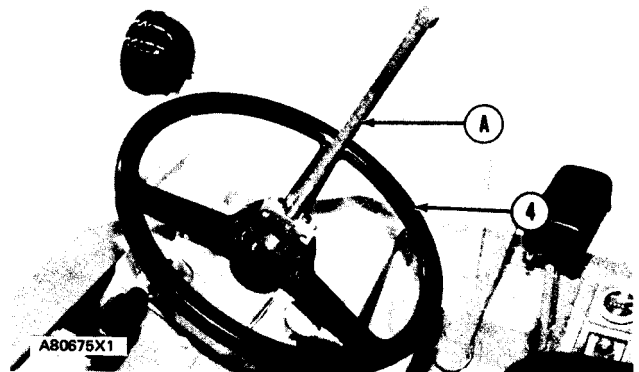

PARKING BRAKE CABLE

Models 950BNS and 950BS

REMOVE PARKING BRAKE CABLE

4284-11

1. Push the top of boot (1) down toward the floor plate so the bottom two bolts in the shroud can be removed.

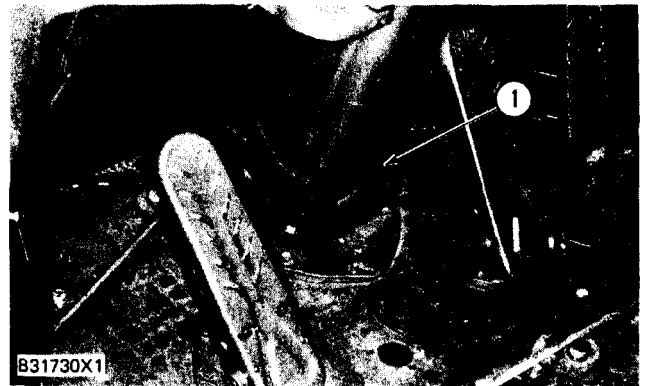

2. Remove four bolts (4) from each side of the steering column. Remove shrouds (2) and (3) from the steering column.

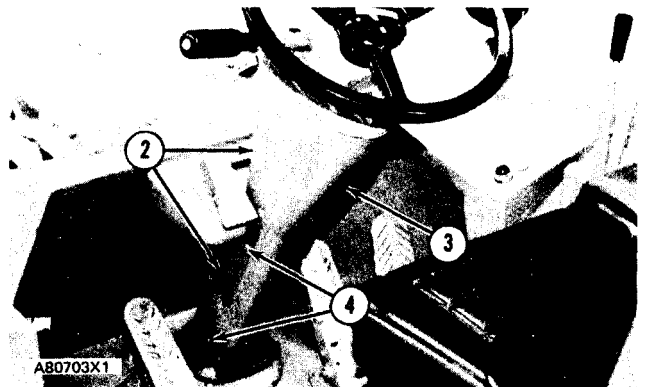

3. Remove knob (6) and locknut from the cable assembly.

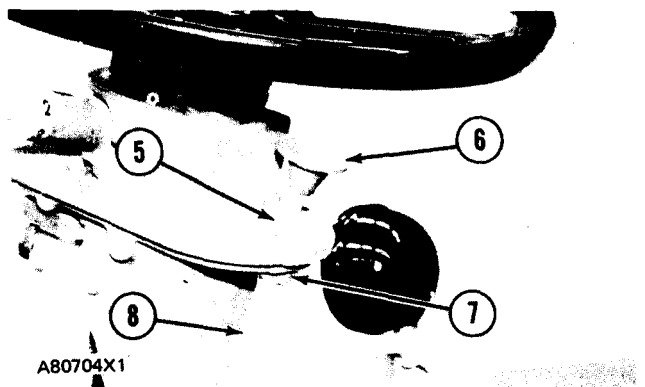

4. Remove nut (5). Pull cable assembly (8) from the housing. Remove nut (7) from the cable assembly.

5. Loosen nut (9) on the bracket assembly.

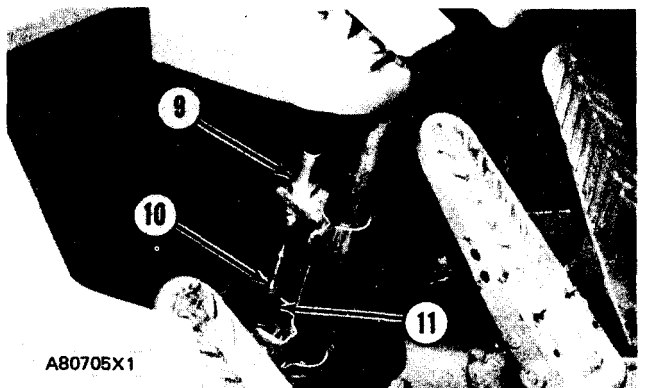

6. Loosen nut (10). Turn parking brake cable counterclockwise until it can be removed from rod (11).

7. Pull the parking brake cable through the steering column support from the bottom. Remove the parking brake cable from the machine.

PARKING BRAKE CABLE

INSTALL PARKING BRAKE CABLE

4284-12

1. Install parking brake cable (1) through the steering column support from the bottom,
2. Turn the cable clockwise and install the threaded end of the cable in rod (4). Tighten locknut (3) on the rod.
3. Put the cable in position in the bracket assembly (2) and tighten the two nuts that hold it.
4. Install nut (6) and lockwasher on the cable assembly.
5. Put the cable assembly in position in the housing. Install nut (5).
6. Install the knob and locknut on the cable.
7. Put shrouds (7) and (8) in position on the steering column and install the bolts that hold them.
8. Put boot (9) in the correct position on the shrouds.

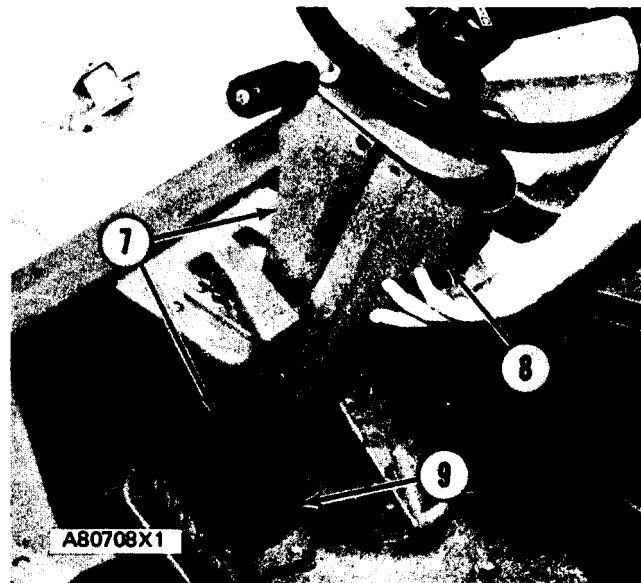
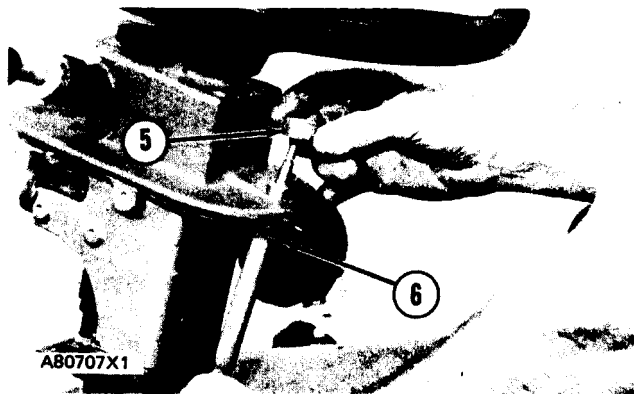
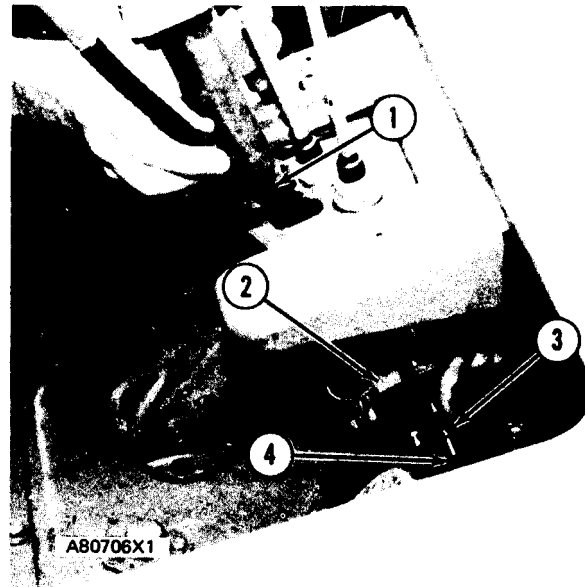

PARKING BRAKE CABLE (Models 950BNSCE, 950 BSCE)

REMOVE PARKING BRAKE CABLE

1. Push top of boot (1) down toward the floor plate so the bottom two bolts in the shroud can be removed.
2. Remove four bolts (4) from each side of the steering column. Remove shrouds (2) and (3) from the steering column.
3. Remove knob (5) and locknut (6) from brake cable assembly (7).
4. Loosen nut (8).
5. Remove two cotter pins (9) and pins (10).
6. Loosen nut (11).
7. Turn parking brake cable (7) counterclockwise until it can be removed from valve (12).

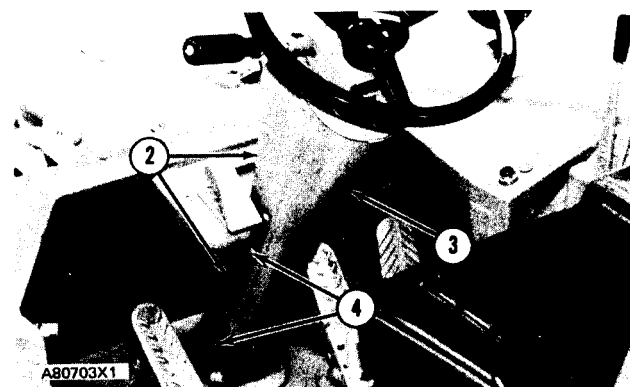
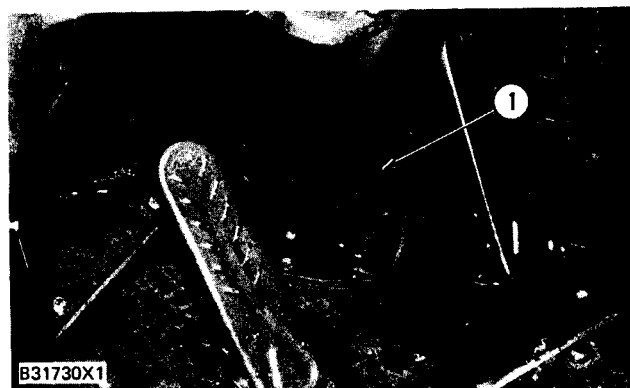

INSTALL PARKING BRAKE CABLE

1. Screw threaded end of parking brake cable (7) into valve (12).
2. Tighten locknut (11).
3. Install pins (10) and cotter pins (9).
4. Tighten nut (8).
5. Tighten locknut (6) and install knob (5).
6. Place shrouds (3) and (2) in position on the steering column and install bolts (4) that retain them.
7. Position boot (1) on the shrouds.

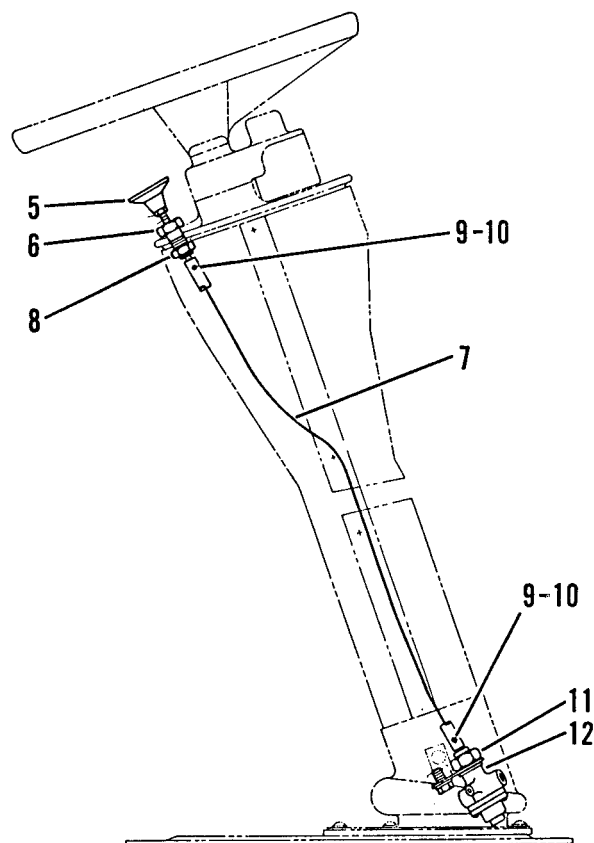

FUSE PANEL

REMOVE FUSE PANEL

1. On the right side of the cab, use the 1/4" square drive wrench that comes with the machine to turn locks (1) counterclockwise to the open position.
2. Pull the top of access panel (2) out and down to open the panel.
3. Remove bolts and nuts (3). Lower fuse panel (4) to the bottom of the platform.
4. Disconnect wiring harnesses (5) and (6). Remove the fuse panel from the machine.

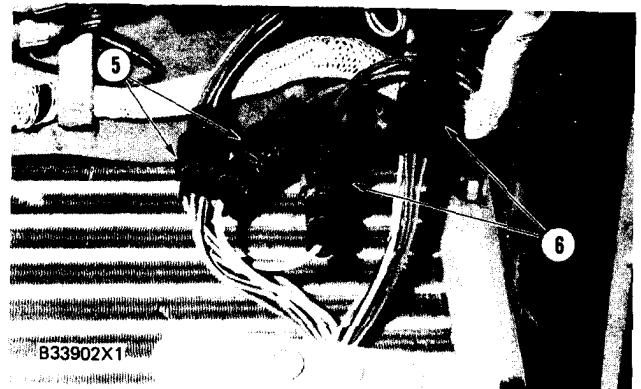
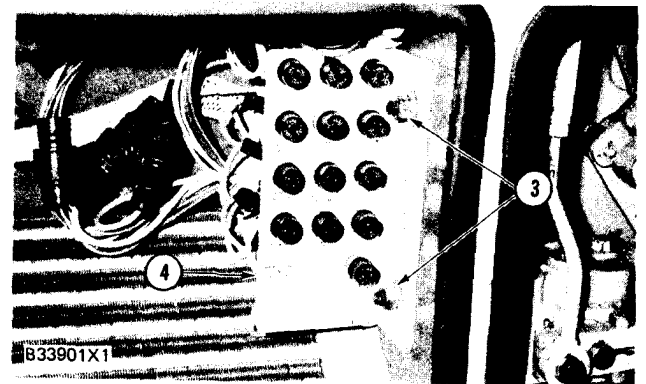
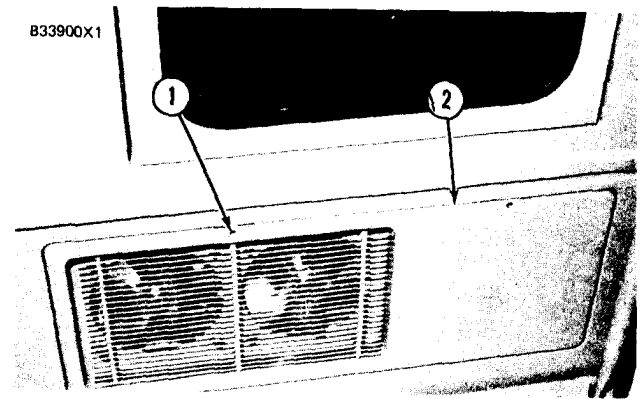

INSTALL FUSE PANEL

1. Connect wiring harnesses (2) to their correct connectors on the main wiring harness.
2. Put fuse panel (1) in position and install the bolts and nuts that hold it.
3. Close access panel. Use the 1/4" square drive wrench that comes with the machine to turn the locks on the panel clockwise.

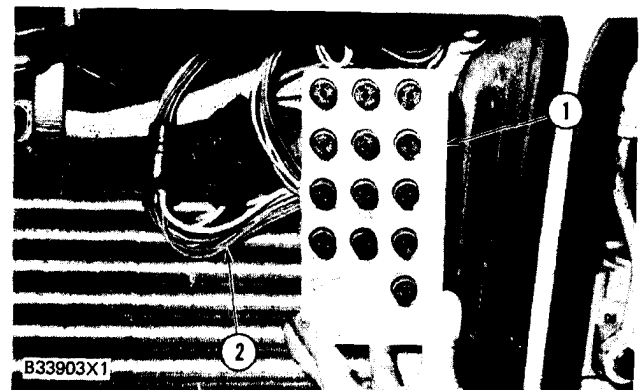

FUSE PANEL

DISASSEMBLE FUSE PANEL

- start by:
a) remove fuse panel

NOTE: Fuses can be removed and installed when the fuse panel is in the machine.

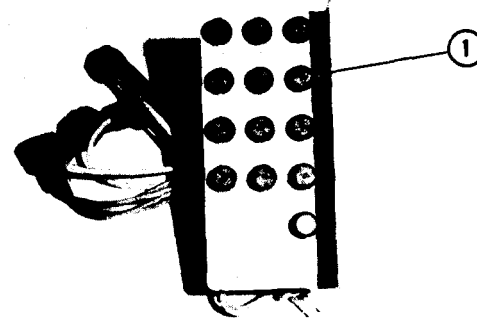

B33904X1

1. Remove fuses as follows:
 - a) Push in on cap (1) and turn counterclockwise $\frac{1}{4}$ turn. Remove cap and fuse from the fuse holder.
 - b) Remove fuse from the cap.

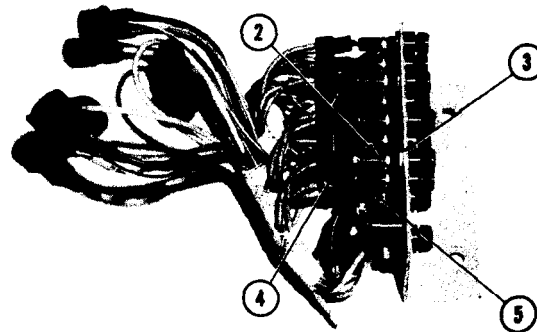

B33905X1

2. Remove fuse holders as follows:
 - a) Disconnect two wires (4) and (5).
 - b) Remove nut (3) and gasket. Remove fuse holder (2) from the front of the panel.

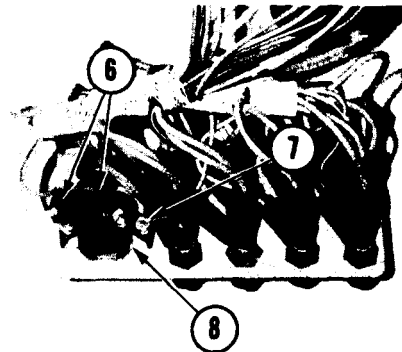

B33906X1

3. Remove circuit breakers as follows:
 - a) Disconnect two wires (6).
 - b) Remove two screws, nuts and lockwashers (7).
 - c) Remove circuit breaker (8) from the panel.

ASSEMBLE FUSE PANEL

1. Install circuit breakers as follows:
 - a) Put circuit breaker (2) in position on the fuse panel. Install the screws, lockwashers and nuts that hold it.
 - b) Connect two wires (1) to the circuit breaker.

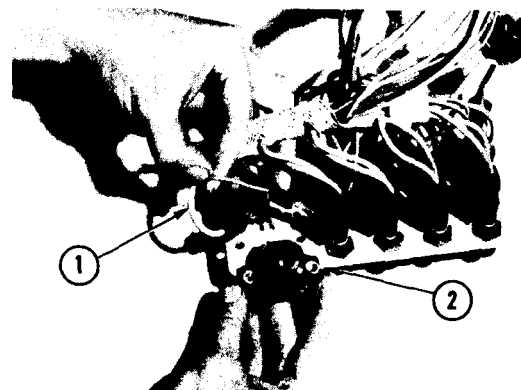

B33909X1

FUSE PANEL

2. Install fuse holders as follows:

- a) Install fuse holder (3) from the front of the fuse panel.
- b) Install the gasket and nut on the fuse holder.
- c) Connect the two wires to the fuse holder.



3. Install fuses as follows:

- a) Install fuse (4) in cap (5).
 - b) Put fuse and cap in position in the fuse panel. Push in on cap and turn clockwise ¼ turn.
- end by:
- a) install fuse panel

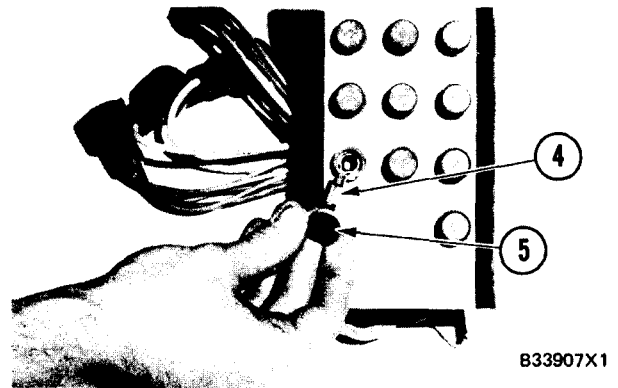

REMOVE MIRROR

7319-11

1. Remove nut (2) and washer. Remove mirror (1) from the bracket.

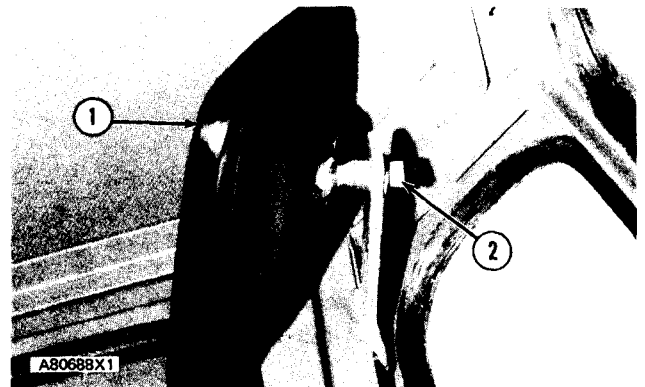

INSTALL MIRROR

7319-12

1. Put mirror (1) in position on the bracket. Install the washer and nut that hold it.



INSTRUMENT PANEL

REMOVE INSTRUMENT PANEL

1. Use the 1/4" square drive wrench that comes with the machine to turn the locks counter-clockwise and open panel (1) on the right side of the machine.
2. Remove the bolts and nuts that hold fuse panel (3) in position. Disconnect wiring harnesses (2) from the fuses and remove fuse panel (3) from the machine.
3. Disconnect wiring harnesses (4), (5) and (6) from the instrument panel wiring.
4. Loosen the two screws and strips that hold the bottom of the instrument panel to the machine. Remove the instrument panel from the inside of the cab.
5. Remove the four nuts (7) and washers to remove the systems monitor group (8) from the instrument panel.

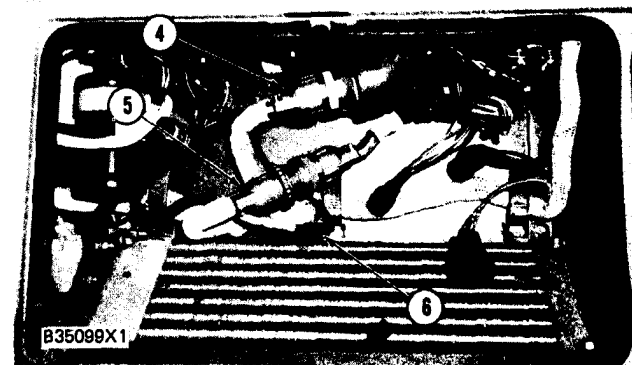
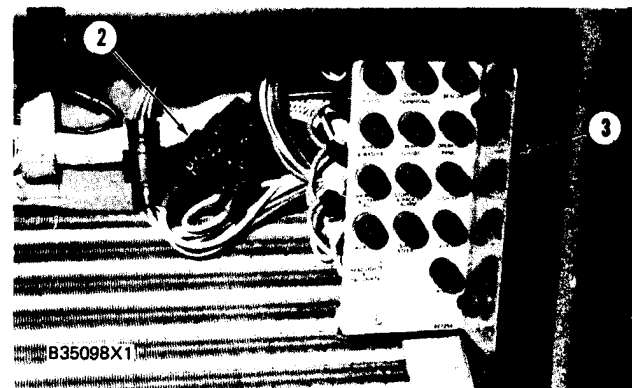
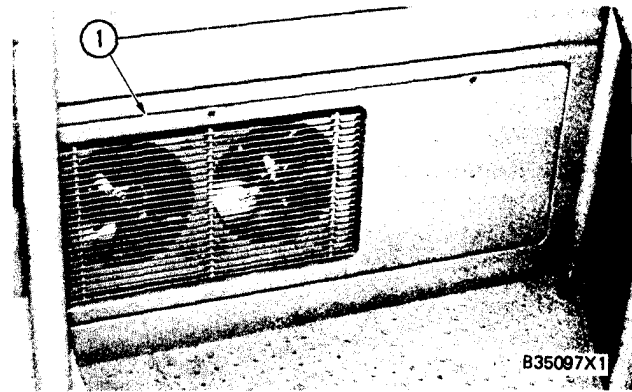

NOTE: The individual parts of monitor group (8) are not serviced separately.

6. Remove panel test switch as follows:
 - a) Disconnect the two wires from the back of switch (10). Put identification on the wires for correct installation.
7. Remove nut (9). Remove switch (10) from the back of the panel.

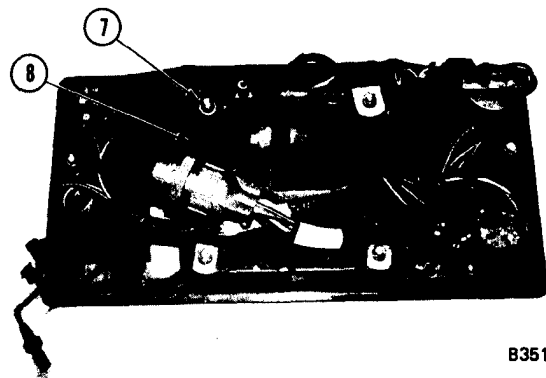
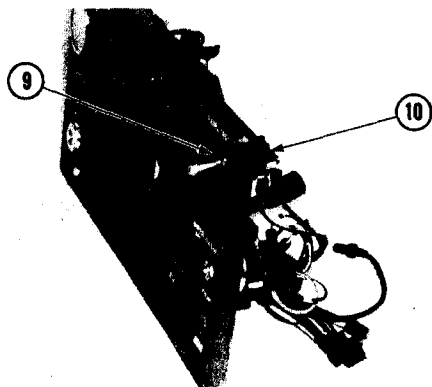

INSTRUMENT PANEL

8. Remove the service meter as follows:
- Disconnect the service meter wires from wiring harness (16).
 - Remove the two wing nuts and bracket (15).
 - Slide service meter (14) out the front of the panel.

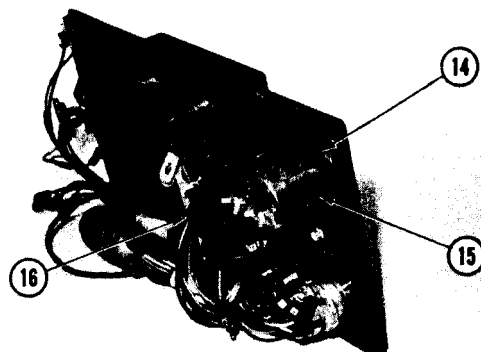

B35103X1

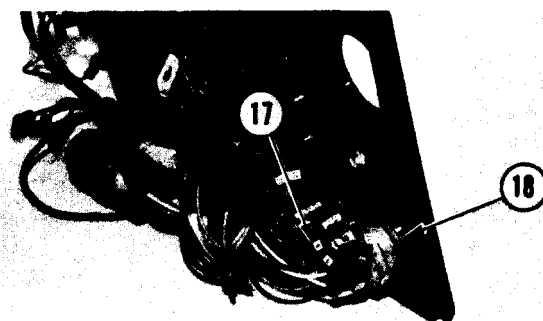

B35104X1

9. Remove start switch as follows:
- Disconnect five wires (17) from the back of switch (18). Put identification on the wires for correct installation.
 - Remove nut (19). Remove switch (18) from the back of the panel.

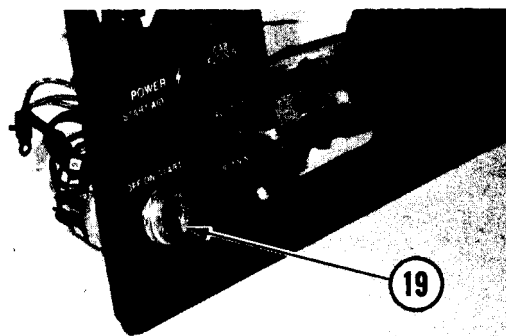

B35105X1

INSTRUMENT PANEL

10. Remove floodlight switch as follows:
- Disconnect two wires from the back of switch (21). Put identification on the wires for correct installation.
 - Remove nut (20). Remove switch (21) from the back of the panel.

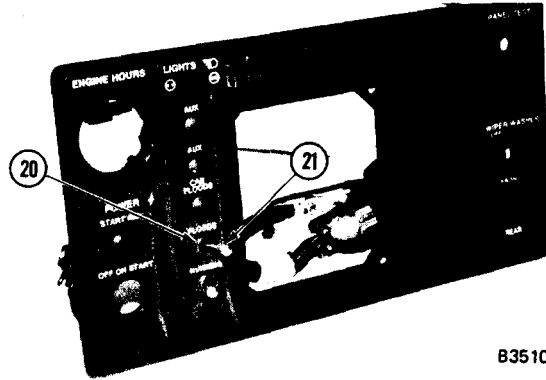

B35106X1

11. Remove running light switch as follows:
- Disconnect five wires from the back of switch (23). Put identification on the wires for correct installation.
 - Remove nut (22). Remove switch (23) from the back of the panel.

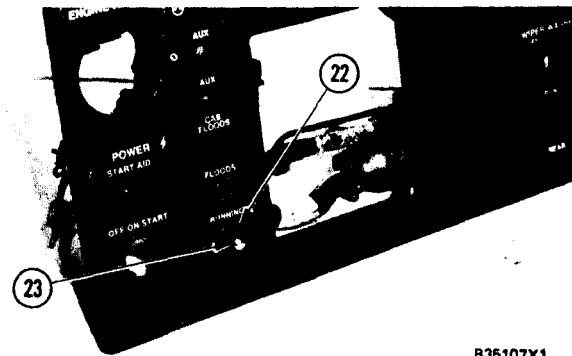

B35107X1

INSTALL INSTRUMENT PANEL 7451-12

1. Install running light switch as follows:
- Connect the five wires to switch (1).
 - Install switch (1) from the back of the panel. Install the nut that holds the switch in position.

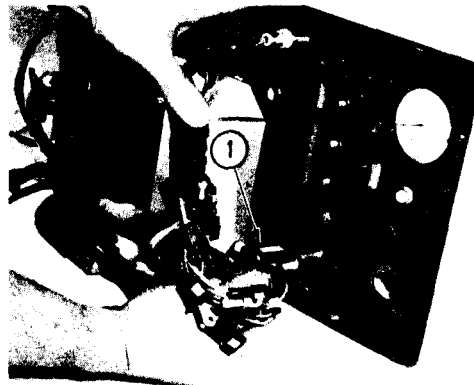

B35108X1

2. Install the floodlight switch as follows:
- Connect the two wires to switch (2).
 - Install switch (2) from the back of the panel. Install the nut that holds the switch in position.

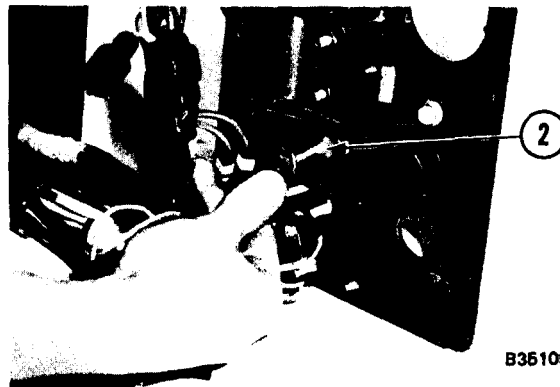

B35109X1

INSTRUMENT PANEL

3. Install the start switch as follows:
 - a) Connect the five wires to the back of switch (3).
 - b) Install switch (3) from the back of the panel.
 - c) Install nut (4) to hold the switch.

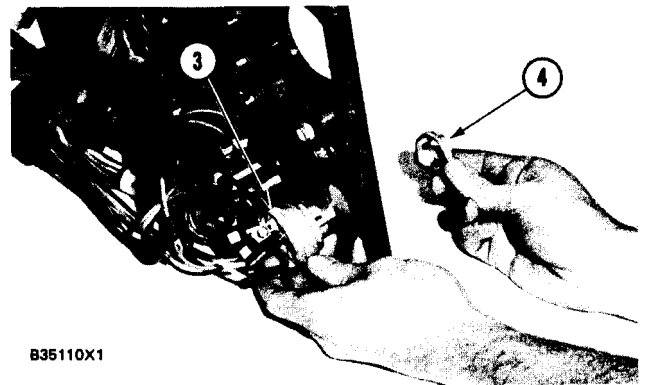

B35110X1

4. Install the service meter as follows:
 - a) Put service meter (5) in position in the panel.
 - b) Install bracket (6) and the two wing nuts to hold the meter in position.
 - c) Connect wires (8) to wiring harness (7).

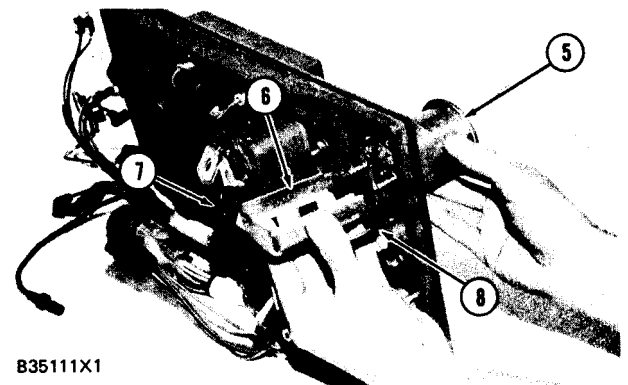

B35111X1

5. Install panel test switch as follows:
 - a) Connect the wires to switch (12).
 - b) Install switch (12) from the back of the panel. Install the nut to hold the switch.

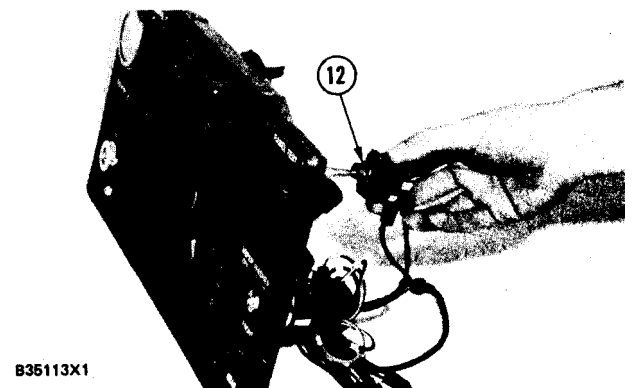

B35113X1

INSTRUMENT PANEL

6. Put seal (13) and the systems monitor group (14) in position in panel (15). Install the washers and nuts to hold monitor group (14) in panel (15).

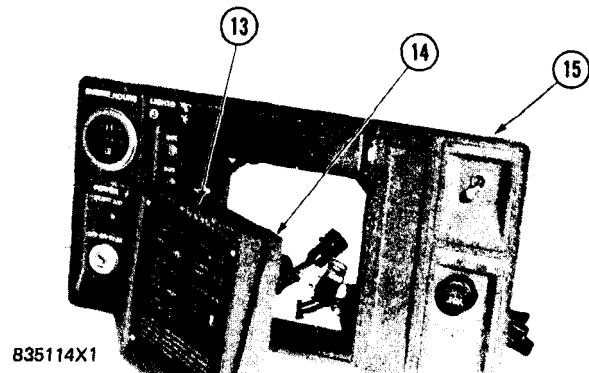

7. Put panel (15) in position on the machine. Move the two strips in position and tighten the screws to hold the panel to the machine.

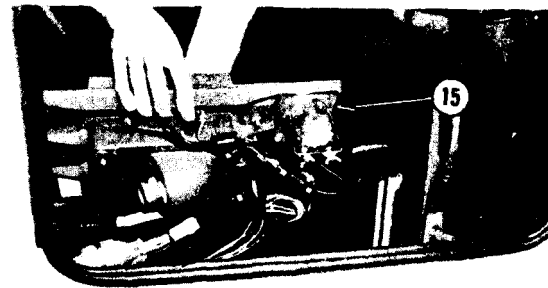

8. Connect wiring harnesses (16), (17) and (18) to the instrument panel wiring.

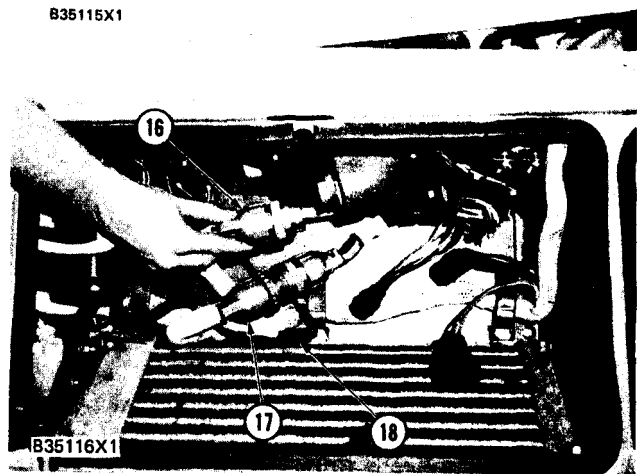

9. Connect wiring harnesses (20) to the fuse panel wiring.

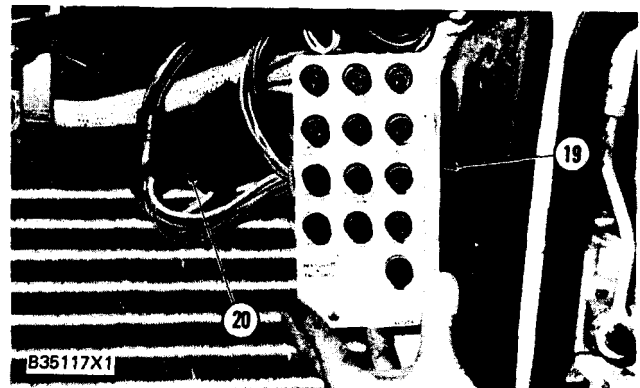

10. Put fuse panel (19) in position and install the bolts, washers and nuts to hold it.

11. Close the access panel on the right side of the machine.

BLACKOUT LIGHTING

REMOVE LIGHTING CONTROL SWITCH

1. Remove two nuts and washers that secure panel (1) to the vehicle cab. Panel is located on the left side of the driver's seat.
2. Disconnect wiring harness cable (2) from the lighting control switch (3).
3. Remove screws (4) and levers (5).
4. Remove four screws (6) and washers (7) that secure switch (3) to panel (1).

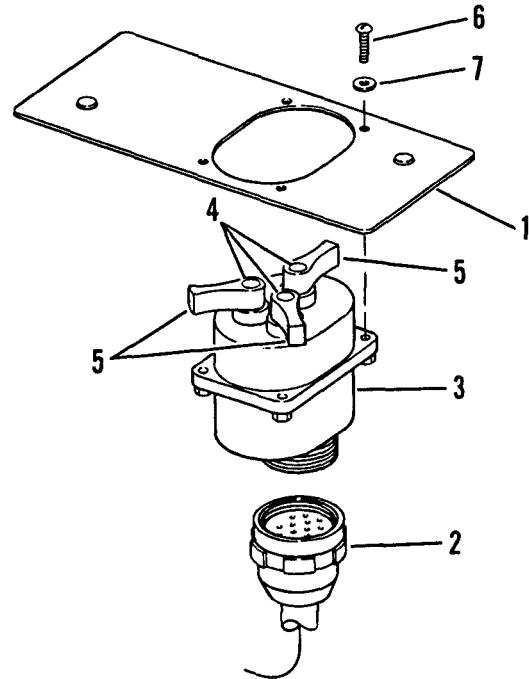

INSTALL LIGHTING CONTROL SWITCH

1. Secure lighting control switch (3) to panel (1) with four screws (6) and washers (7).
2. Secure levers (5) with screws (4).
3. Connect wiring harness cable (2) to the switch.
4. Secure panel (1) to vehicle cab with two nuts and washers.

REMOVE BLACKOUT LAMP ASSEMBLY

1. Disconnect wiring (1) from the back of the blackout light (2).
2. Remove nut (3), lockwasher (4), and blackout light (2).

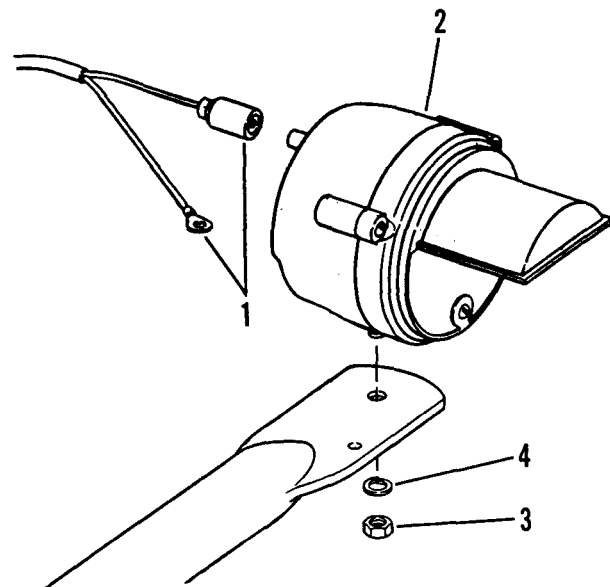

INSTALL BLACKOUT LAMP ASSEMBLY

1. Secure blackout light (2) with lockwasher (4) and nut (3).
2. Connect wiring (1) to the back of the light.

BLACKOUT LIGHTING

REMOVE LIGHTING CONTROL RELAYS

1. Remove instrument panel. Refer to: Remove Instrument Panel (preceding section).
2. There are seven control relays for the lighting control circuit. The seven relays are located under the instrument panel which was removed in step (1). Four of the relays are mounted on a bracket at the back of the Instrument panel and wiring harness enclosure and the other three relays are mounted on a bracket towards the front.

NOTE: Tag all wiring before disconnecting the wiring from the relay(s).

3. All of the relays are mounted in the same manner. To remove a relay, pull wiring harness connectors (1) off of the relay terminals.
4. Remove two nuts (2), washers (3), bolt (4) and relay(s) (5).

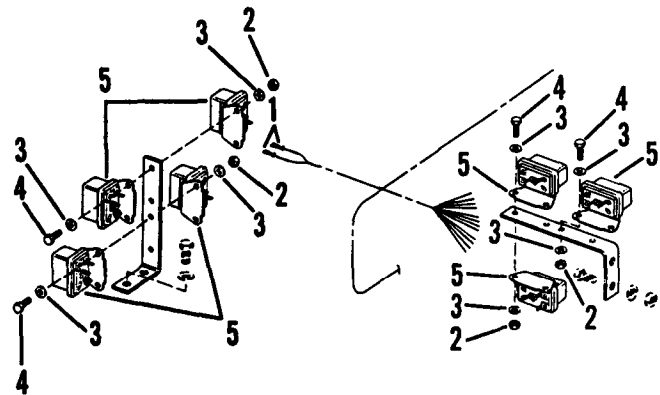

INSTALL LIGHTING CONTROL RELAYS

1. Secure relay(s) (5) with bolt (4), washers (3) and nuts (2).
2. Push wiring harness connectors (1) on the relay terminals. Use tags made during removal for wire identification.
3. Install instrument panel. Refer to: Install Instrument Panel (preceding section).

REMOVE BLACKOUT TAIL LAMP ASSEMBLY

1. Disconnect wiring (1) from the back of the blackout tail lamp (2).
2. Remove capscrews (3), lockwashers (4), and blackout tail lamp (2).

INSTALL BLACKOUT TAIL LAMP ASSEMBLY

1. Secure blackout tail lamp (2) with lockwashers (4) and capscrews (3).
2. Connect wiring (1) to the back of the blackout tail lamp.

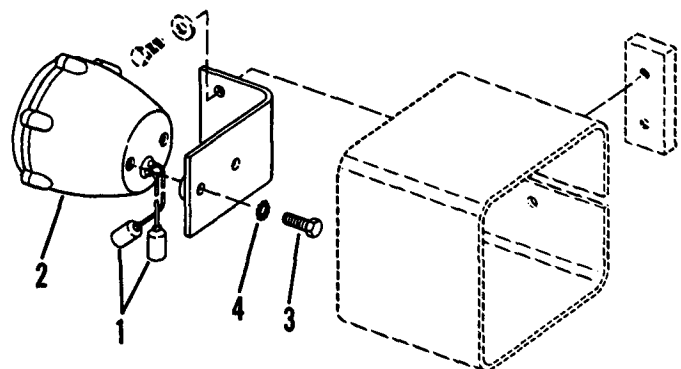

GOVERNOR PEDAL GROUP

Models 950BNS and 950BS

REMOVE GOVERNOR PEDAL GROUP

1265-11

1. Remove nut (2) and disconnect rod assembly (1) from the lever.
2. Remove cotter pin (8) and washer. Disconnect yoke (6) from the lever.
3. Remove spring (4).
4. Remove cotter pin and pin (5). Remove collar (7). Remove lever assembly (3).
5. Remove three bolts (10). Remove governor pedal (9) and base assembly as a unit.

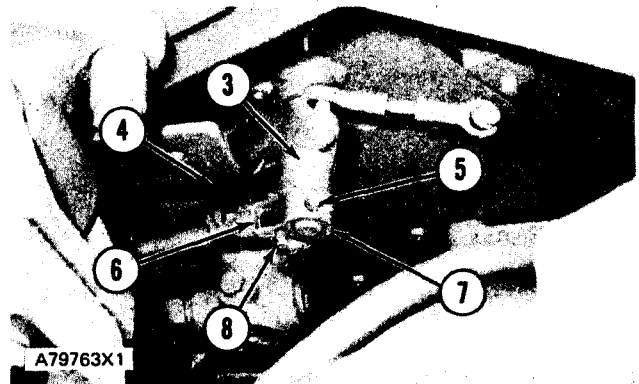
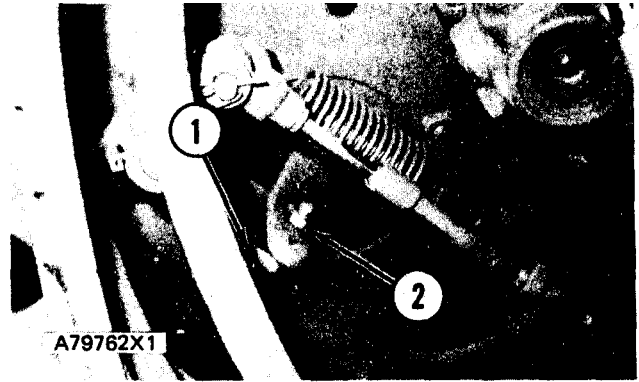
**INSTALL GOVERNOR PEDAL GROUP**

1265-12

1. Put governor pedal (1) and base assembly in position. Install the bolts that hold it.
2. Put lever assembly (3) in position. Install the collar, pin and cotter pin that hold it on the shaft.
3. Install the spring on the lever assembly.
4. Connect yoke (4) to the lever assembly.
5. Connect rod assembly (2) to the lever assembly.
6. Make an adjustment to the pedal assembly so it is at a $66^\circ \pm 3^\circ$ angle with the floor when the engine governor shaft is in the "OFF" position.

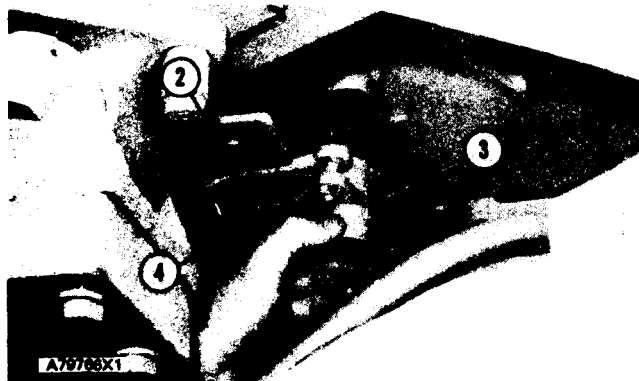
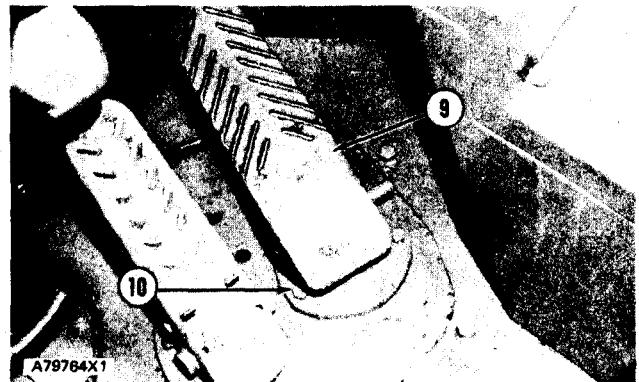

GOVERNOR PEDAL GROUP

Models 950BNS and 950BS

DISASSEMBLE GOVERNOR PEDAL GROUP

1265-15

Tools Needed		A
1P510	Driver Group	1

start by:

a) remove governor pedal group

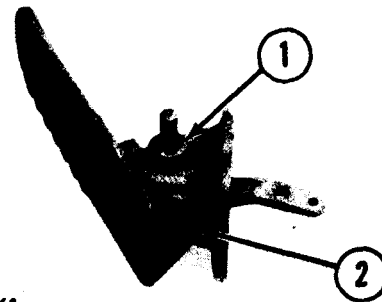

A79767X1

1. Remove cotter pin and washer (1) from the shaft.

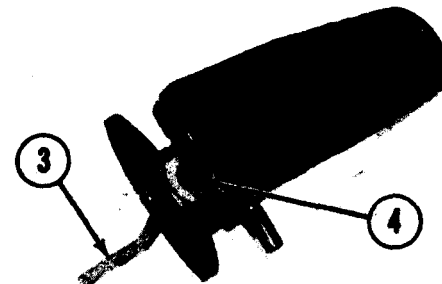

A79768X1

2. Remove plug (2) from the base assembly.

3. Loosen bolt (4). Remove base assembly and lever (3) from the pedal assembly.

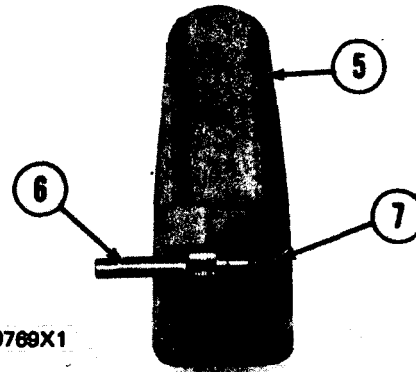

A79769X1

4. Remove screw (7). Remove shaft (6) from pedal (5).



A79771X1

5. Remove bearing and bushing (8) from base assembly (9) with tooling (A).

GOVERNOR PEDAL GROUP

Models 950BNS and 950BS

6. Remove rod assembly (11) from lever (12).

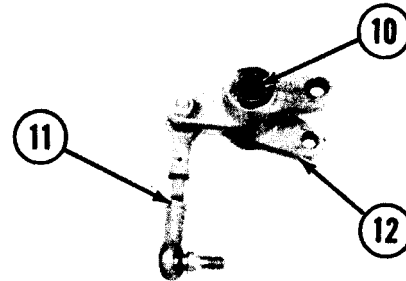

A79770X1

7. Remove bearings (10) from the lever with tooling (A).

ASSEMBLE GOVERNOR PEDAL GROUP

1265-16

Tools Needed		A
1P510	Driver Group	1

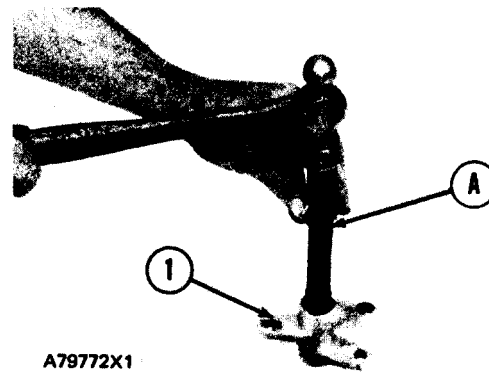

A79772X1

1. Install bearings in lever (1) with tooling (A). Install one bearing in each end of the lever even with the surface of the lever.

2. Make an adjustment to the length of the rod assembly so the distance between the center-lines of the rod ends is 85 ± 1 mm ($3.346 \pm .039$ in.).

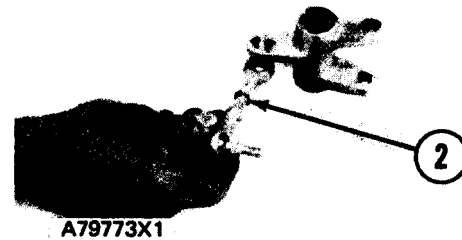

A79773X1

3. Install rod assembly (2) on the lever.

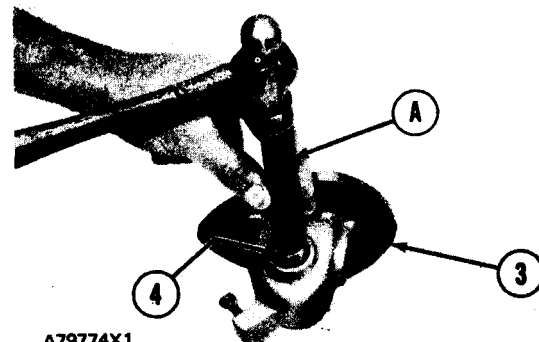

A79774X1

4. Use tooling (A) to install bushing (4) even with the surface of base (3). Install bearing on the opposite side of the base with tooling (A) even with the surface of the base.

GOVERNOR PEDAL GROUP

Models 950BNS and 950BS

5. Install shaft (6) in pedal (5). Put 9M3710 Anti-Seize Compound on the threads and install screw (7) in the pedal to hold shaft in position.

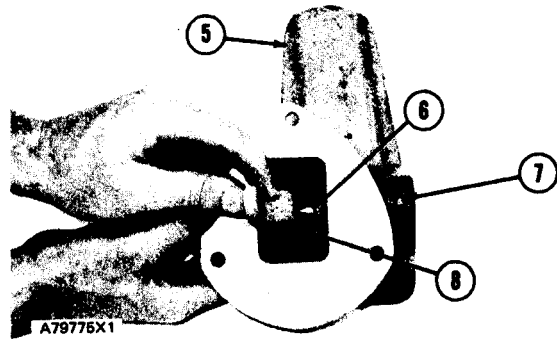

6. Install base assembly and lever (8) on the shaft as shown.

NOTE: Lever (8) and pedal (5) must beat a $140^\circ \pm 3^\circ$ angle as shown when the lever is installed on the shaft.

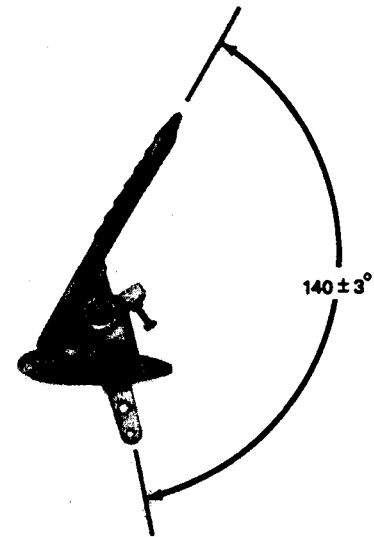

7. Install plug (11) in the base.

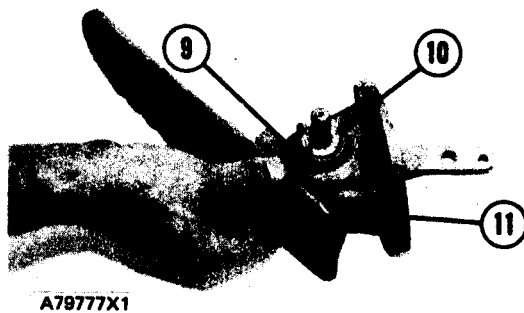

8. Install washer (10) and cotter pin (9) on the shaft. end by:
 - a) install governor pedal group

GOVERNOR PEDAL GROUP Models 950 BNSCE and 950BSCE

REMOVE GOVERNOR PEDAL GROUP

1. Remove set screw (1) and governor pedal (2).
2. Remove two bolts (3), washers (4), and bar (5).
3. Remove three bolts (6), washers (7), cover (8), and gasket (9).
4. Remove cotter pin (10) and pin (11).
5. Unscrew rod end (12) from governor cable (13).
6. Remove spring guide (14) and spring (15).
7. Remove nut (16) and spring guide (17).
8. Remove governor cable (13) and seal (18) from pedal housing (19).
9. Remove four bolts (20) and pedal housing (19).

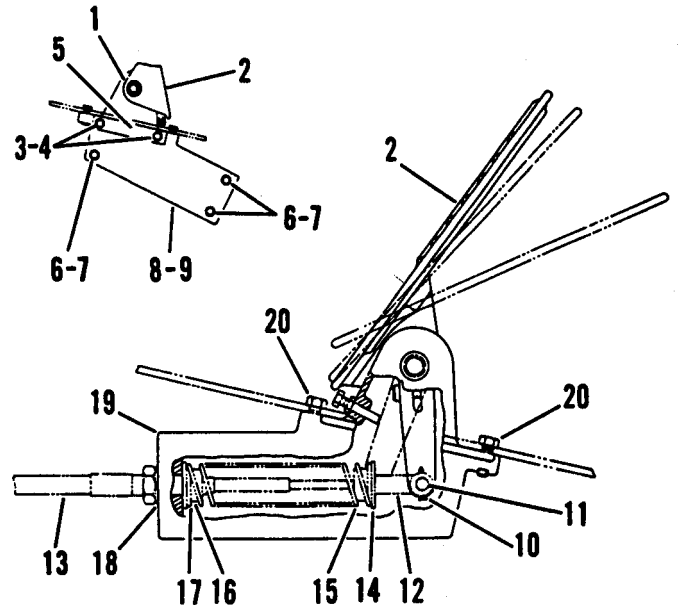

INSTALL GOVERNOR PEDAL GROUP

1. Secure pedal housing (1) with four bolts (2).
2. Install seal (3) and governor cable (4).
3. Install spring guide (5) and nut (6).
4. Install spring (7) and spring guide (8).
5. Screw rod end (9) on governor cable (4).
6. Install pin (10) and cotter pin (11).
7. Install gasket (12), cover (13), washers (14), and bolts (15).
8. Install bar (16), washers (17) and bolts (18).
9. Secure governor pedal (19) with setscrew (20).

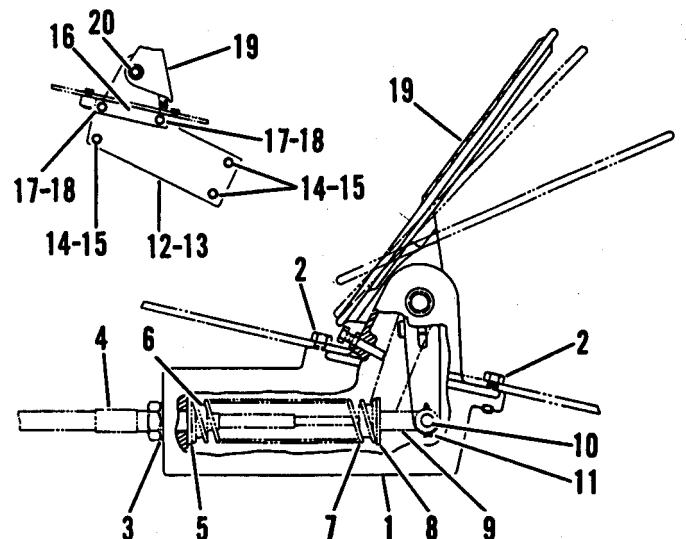

BRAKE PEDAL

REMOVE BRAKE PEDAL

4250-11

1. Remove spring pin and pin (2) from the treadle assembly.

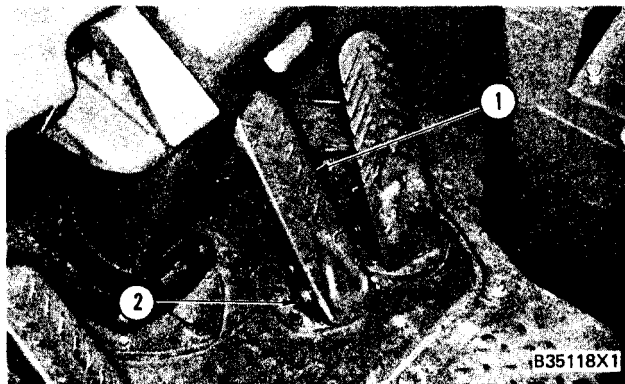

2. Remove treadle assembly (1).

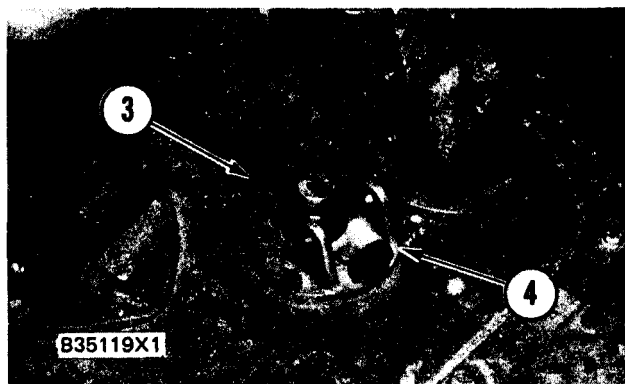

3. Remove bolts (3). Remove plate assembly (4).

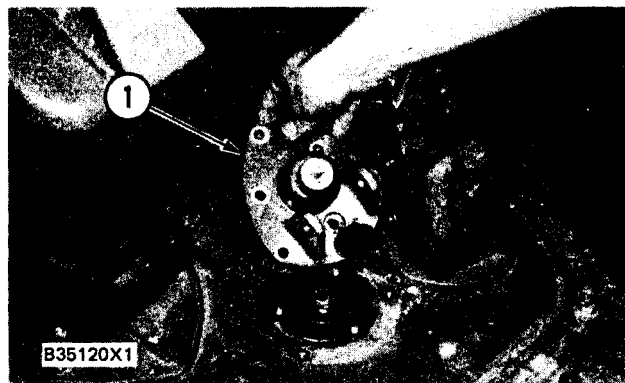

INSTALL BRAKE PEDAL

4250-12

1. Put plate assembly (1) in position on the floor. Install the bolts that hold it.

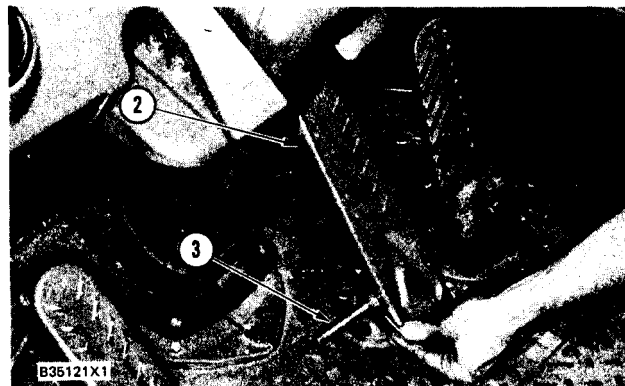

2. Put treadle assembly (2) in position on the plate assembly. Install pin (3) and spring pin in the treadle assembly.

BRAKE PEDAL

DISASSEMBLE BRAKE PEDAL

4250-15

start by:

a) remove brake pedal

1. Remove cotter pin and pin (2). Remove roller (1) from the treadle.

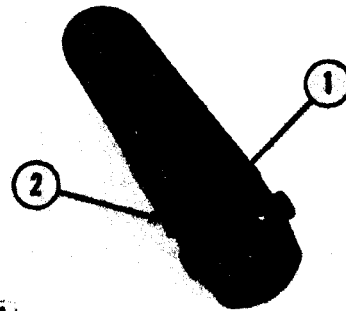

A79782X1

2. Remove boot (4) and plunger (3) from the plate assembly as a unit. Remove the boot from the plunger. Remove button (5).

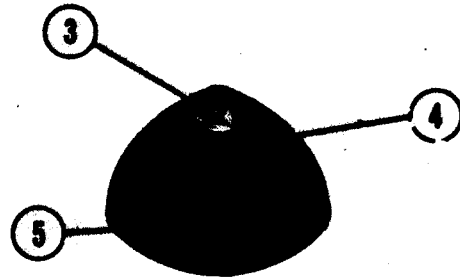

A79783X1

ASSEMBLE BRAKE PEDAL

4250-16

1. Install boot (2) on plunger (1). Install the plunger and boot in the plate.

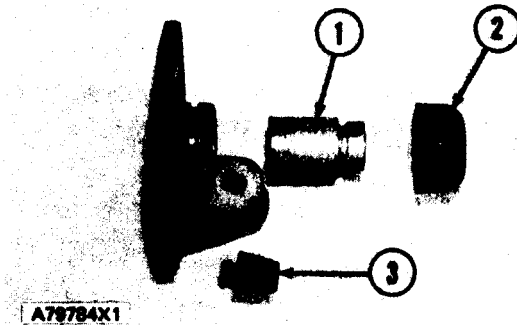

A79784X1

2. Install button (3) in the plate.

3. Put roller (4) in position in the treadle. Install pin (5) and cotter pin.

end by:

a) install brake pedal

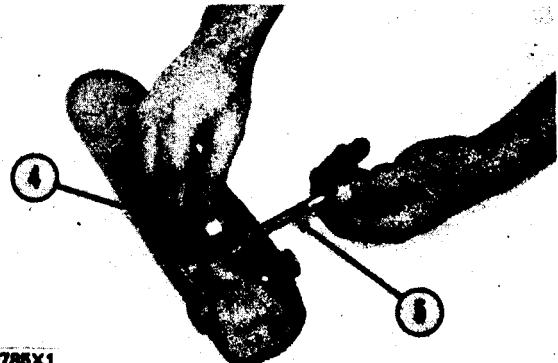

A79785X1

ADJUSTABLE STEERING COLUMN

REMOVE ADJUSTABLE STEERING COLUMN

4310-11

1. Remove four bolts (2). Remove plates (3).
2. Slide boot (1) up the steering column.
3. Remove four bolts (6) from each side of the steering column.
4. Pull boot down below the shrouds. Remove shrouds (4) and (5) from the steering column.
5. Disconnect balljoint (7) from the bellcrank. Remove the balljoint from cable (8).
6. Remove seals (9) and (11) from the cable.
7. Remove nut (12) and pull cable (8) clear of the steering column.
8. Do the procedure in Steps 5 through 7 again for cable (10).
9. Remove knob (13) from the parking brake cable.
10. Remove nuts (15) and pull parking brake cable (14) clear of the steering column.
- 11a. For models 950BNS and 950BS, remove clamps (17) from the steering column.
- 11b. Pull bracket assembly (16) clear of the steering column.
12. For models 950BNSCE and 950BSCE, remove two bolts from parking brake air valve. Move air valve away from steering column.

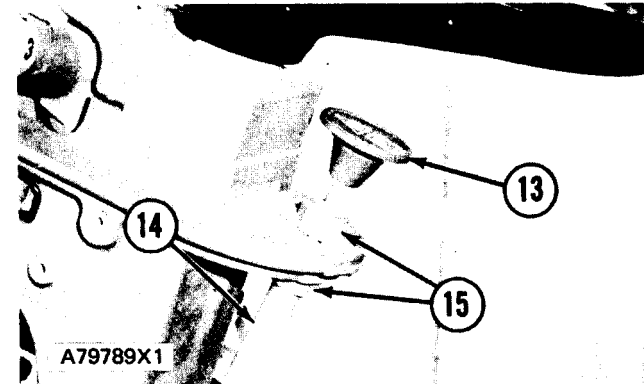
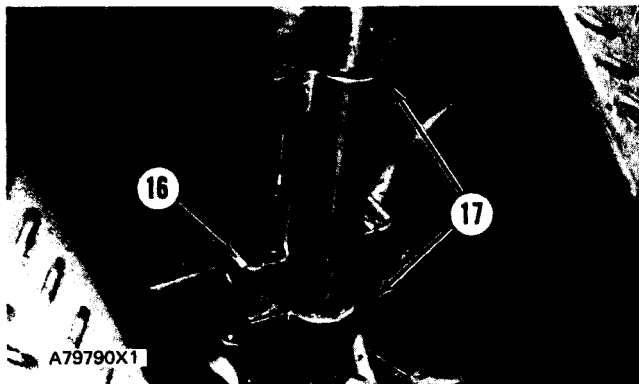
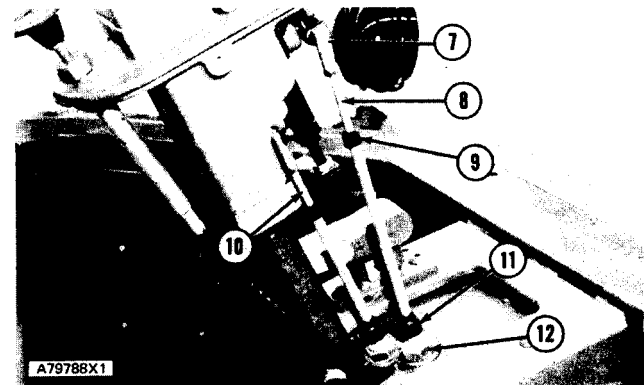
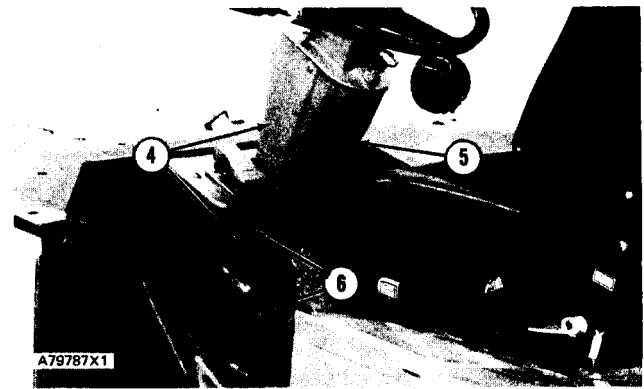
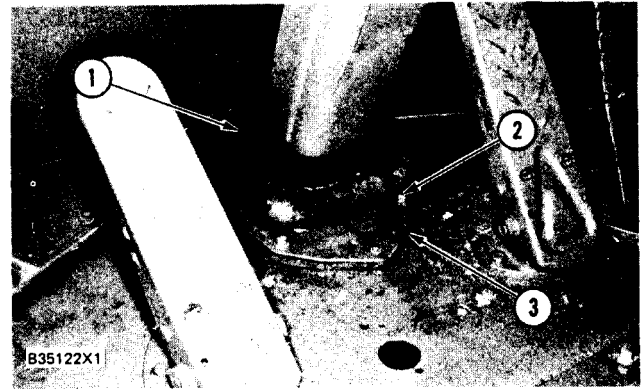

ADJUSTABLE STEERING COLUMN

13. Remove four bolts (18). Pull hand metering pump (19) clear of the steering column.

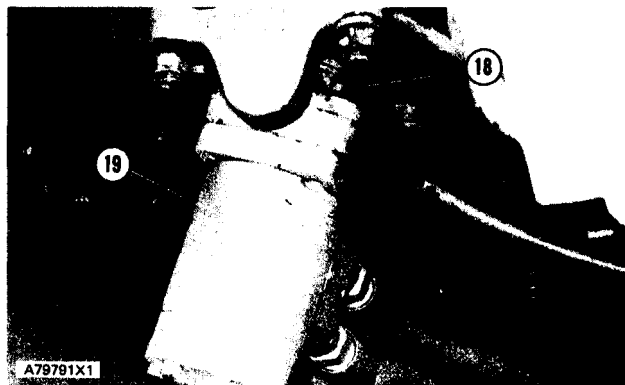

14. Fasten a hoist to the steering column. Remove the two bolts and four nuts that hold the steering column bracket to the platform. Remove four nuts (21). Lower the steering column assembly. Remove two brackets (20). Remove the steering column assembly (22) from the machine. The weight of the steering column assembly is 19 kg (42 lb.).

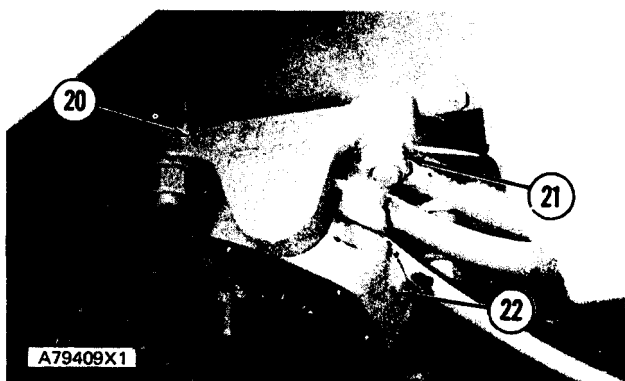

INSTALL ADJUSTABLE STEERING COLUMN 4310-12

1. Put steering column assembly (2) in position through the floor. Install brackets (1) on the steering column. Pull the steering column assembly up and put the brackets in position on the studs in the bottom of the platform. Install the four nuts that hold the brackets in position.

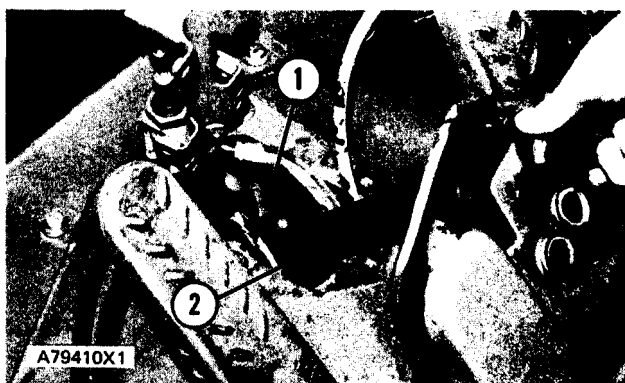

2. Put the steering column bracket assembly (3) in position on the platform. Install the bolts and nuts that hold it.



NOTE: See Assemble Adjustable Steering Column Step 27 for the correct adjustment of the nuts on the steering column tilt lock shaft.

ADJUSTABLE STEERING COLUMN

3. Install hand metering pump (4) on the steering column assembly.

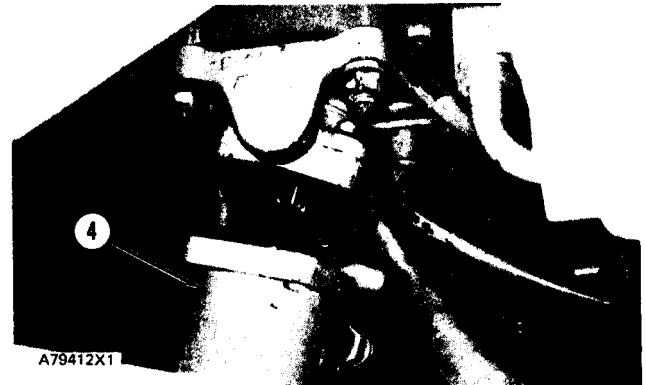

4. Put transmission cables (5) and parking brake cable in position in the steering column support.

5. Put bracket assembly (7) in position on the steering column. Install clamps (6) on the bracket assembly.

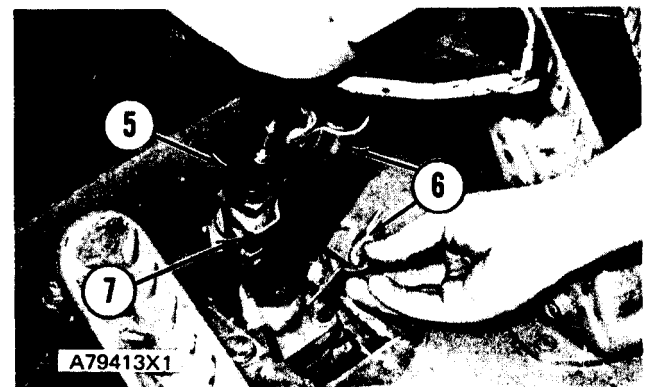

6. Install the nuts that hold the transmission cable assemblies in position on the steering column support.

7. Install seals (9) and (10) on the cable assemblies.

8. Install ballpoints (8) on the cable assemblies. Turn the handle on the transmission control lever to the "FIRST" speed.

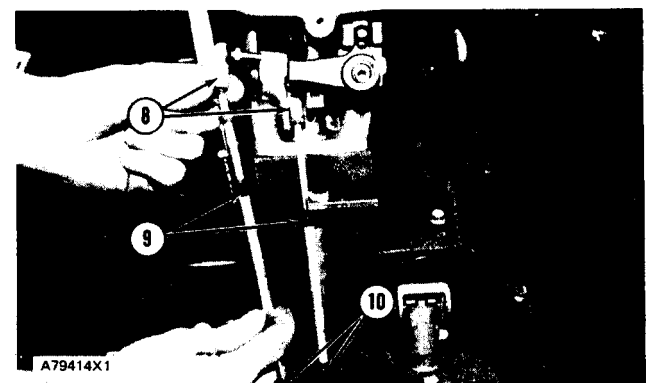

9. Connect speed control cable assembly (12) to the rack on the transmission control.

NOTE: On models 950BNSCE and 950BSCE, put washer on threaded stud of control cable assembly (11) ball joint.

10. Put the transmission control lever in the "NEUTRAL" position. Connect direction control cable assembly (11) to the bellcrank on the transmission control.

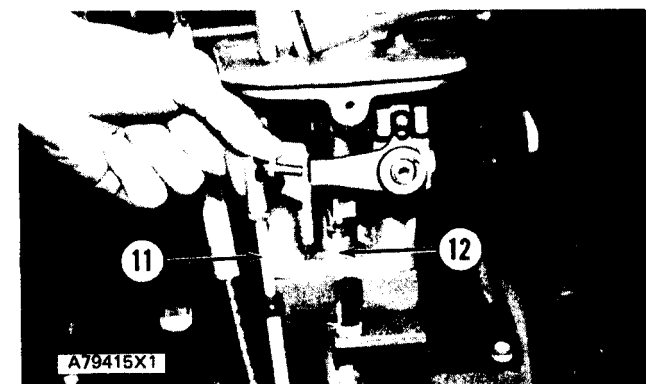

NOTE: Make an adjustment to the transmission control linkage. See TRANSMISSION CONTROL LINKAGE ADJUSTMENTS in POWER SHIFT TRANSMISSION TESTING AND ADJUSTING.

ADJUSTABLE STEERING COLUMN

11. Make an adjustment to plastic collar (13) on the transmission selector lever, so the arrow shows "FIRST" speed when the selector lever is in the "FIRST" speed position.

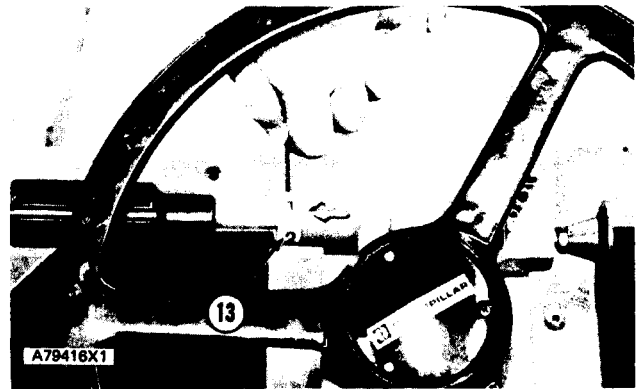

12. Put the parking brake cable in position in the steering column housing.

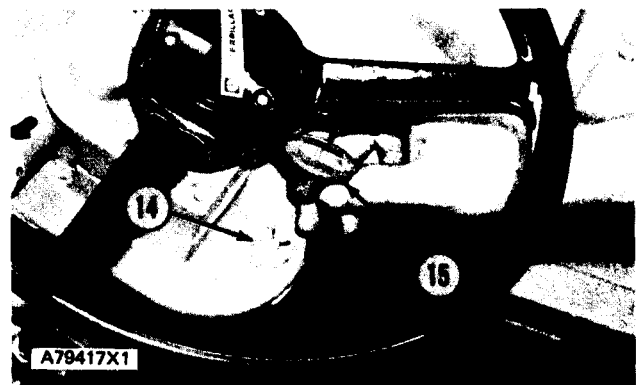

13. Install nut (14) that holds the cable.

14. Install the locknut and knob (15) on the parking brake cable.



15. Slide boot (17) to the bottom of the steering column.

16. Install shrouds (16) and (18).



17. Put plates (19) and (20) in position over the boot. Install the bolts that hold the plates and boot to the floor plate.

ADJUSTABLE STEERING COLUMN

DISASSEMBLE ADJUSTABLE STEERING COLUMN 4310-15

Tools Needed		A	B
1P70	Heed	1	
5F7345	Screw	1	
2B8593	Bolt	2	
484276	Weeher	2	
8B7554	Bearing Puller Attachment		1
8B7553	Screw		1
7S7786	Leg		2

start by:

a) remove adjustable steering column

1. Remove three screws (1). Remove cover (2) from the steering wheel.

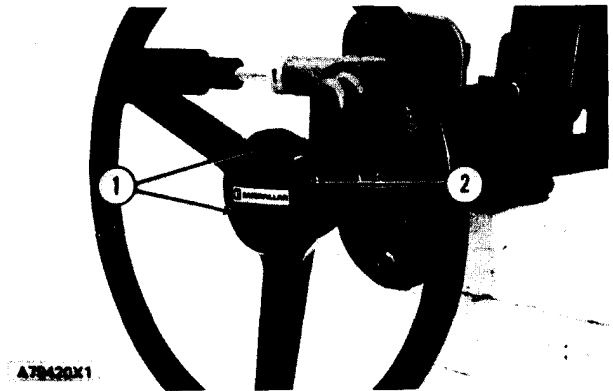

2. Remove the nut from the steering shaft.

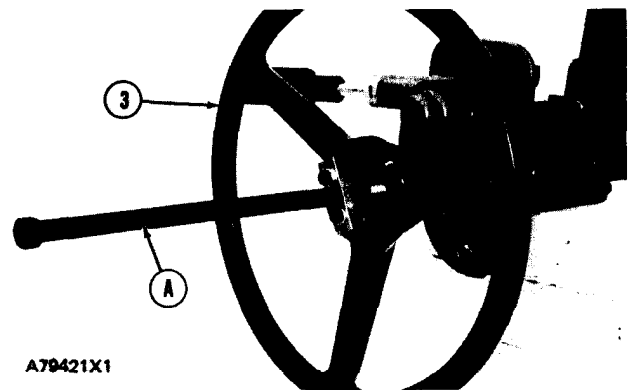

3. Remove steering wheel (3) with tooling (A) as shown.

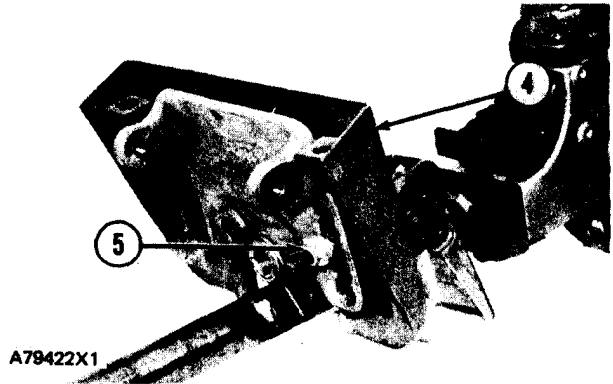

4. Remove two nuts (5) from the shaft. Remove bracket assembly (4) from the steering column.

5. Remove two screws (6). Remove steering column tilt lock (7) from the bracket.

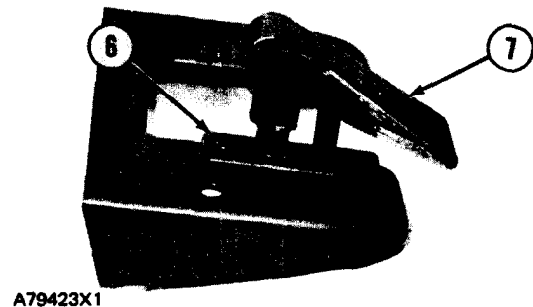

ADJUSTABLE STEERING COLUMN

6. Remove dowels (8) with a hammer and punch.

7. Remove lever (9), boss (11), spring and shaft (12) from support (10).

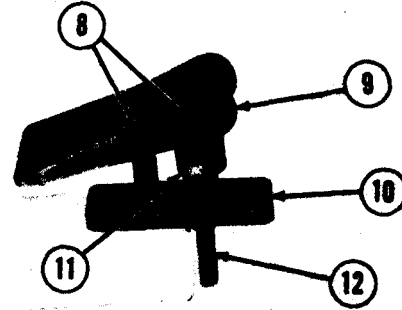

A79424X1

8. Remove four bolts (14). Remove plate (13), bolt and nut.

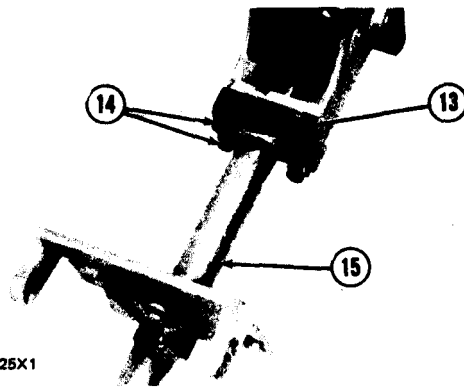

A79425X1

9. Remove column assembly (15) from the housing.

10. Remove four bolts (17). Remove cap assembly (18) from housing (16).

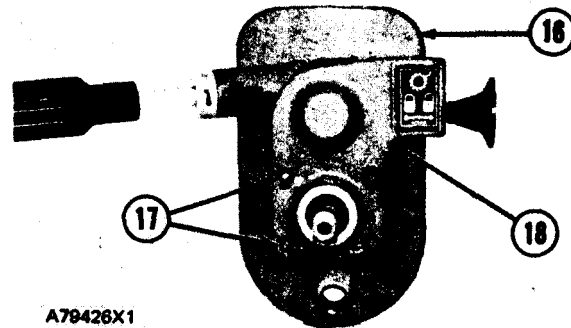

A79426X1

11. Remove lever assembly (19) from the cap assembly.

12. Twist handle (20) and remove rack (21) from the lever assembly.

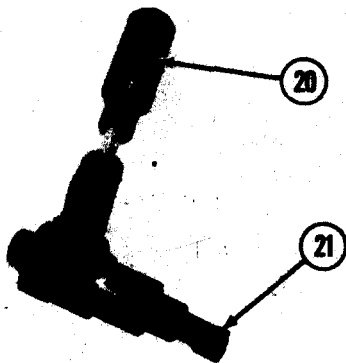

A79428X1

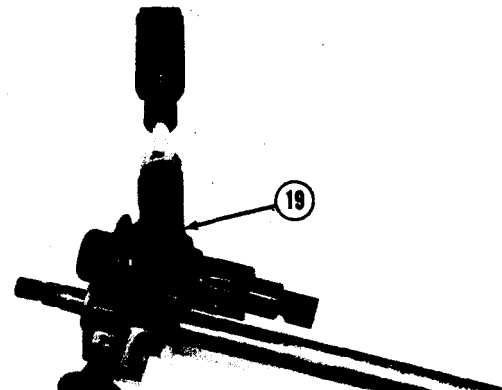

A79427X1

ADJUSTABLE STEERING COLUMN

13. Remove screw (22) and remove handle (20) from the shaft.

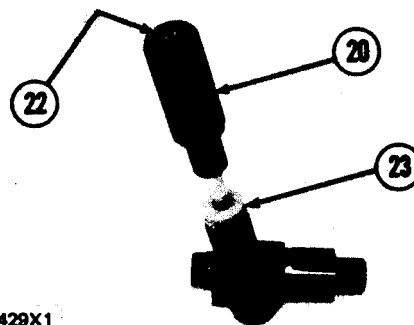

14. Loosen setscrew and remove collar (23).

15. Remove retainer ring (25). Remove retainer (26), spacer and shaft (24) from the lever.

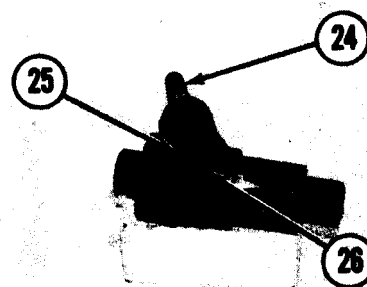

16. Remove seal (27) and two bushings from the lever assembly.

17. Remove setscrew (28). Remove spring and detent ball from under the setscrew.

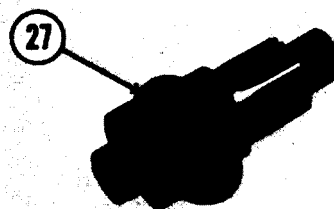

18. Remove retainer ring (30). Remove pin (31) and knob from the cap assembly.

19. Remove knob (29) and locknut from the pin.

20. Remove retainer ring (33). Remove tube assembly (32) and bearing from the cap.

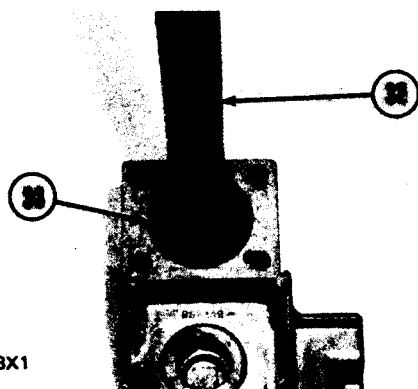
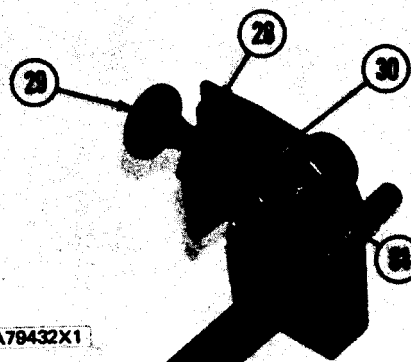

ADJUSTABLE STEERING COLUMN

21. Remove retainer ring (34) from the tube assembly.

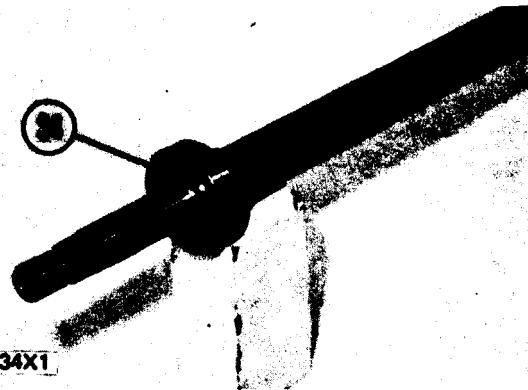

22. Use tooling (B) to remove bearing (35) from the tube assembly.

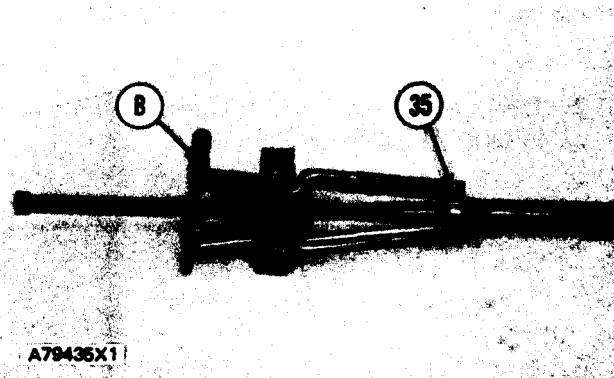

23. Remove seal (36) from the cap.

24. Loosen setscrews (40). Remove bellcrank and pin (38) from the housing.

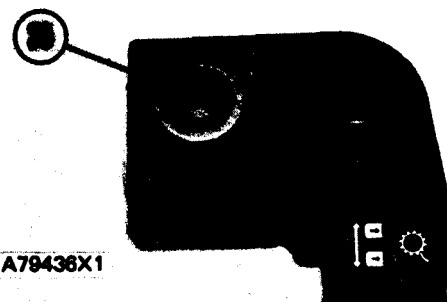

25. Loosen setscrew (39). Remove pin, gear assembly (37) and four washers.

26. Remove bearing (41) from the gear.

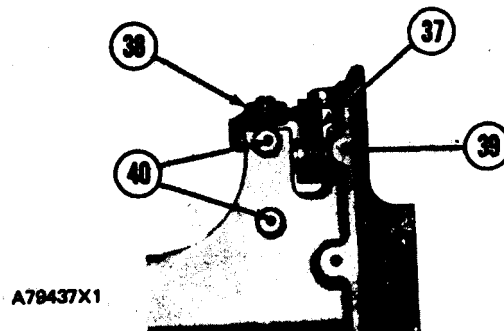
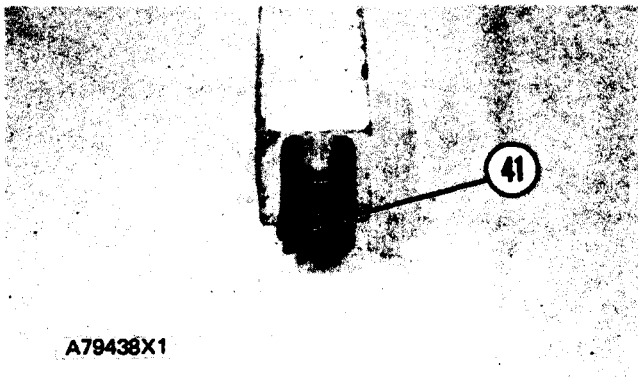

ADJUSTABLE STEERING COLUMN

ASSEMBLE ADJUSTABLE STEERING COLUMN 4310-16

Tools Needed		A
1P510	Driver Group	1

1. Use tooling (A) to install the bearing (1) even with the surface of the gear.

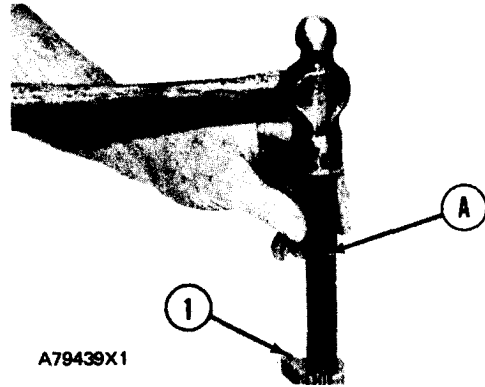

2. Install gear assembly (3), washers and pin in the housing. Tighten setscrew (5).

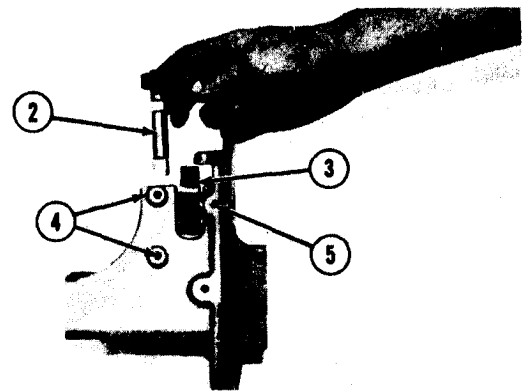

3. Install bellcrank and pin (2). Tighten setscrews (4).

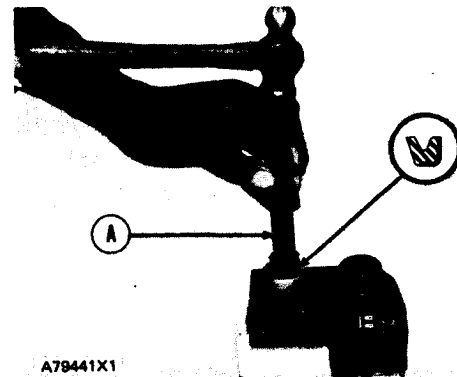

4. Use tooling (A) to install the lip seal in the cap even with the bottom of the chamfer in the bore.

5. Use a press to install bearing (7) on tube assembly (6). Install bearing with the seal opposite the threaded end of the tube assembly.

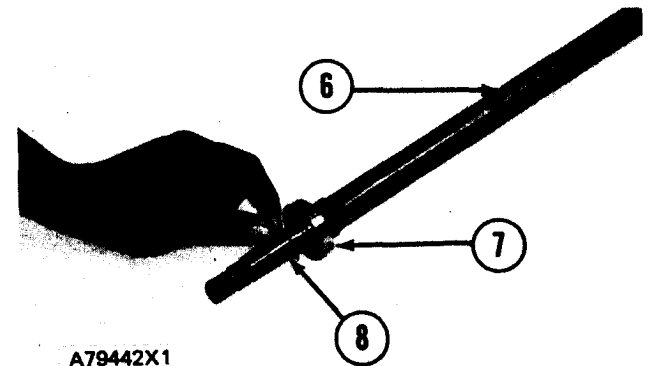

6. Install retainer ring (8) on the tube assembly.

ADJUSTABLE STEERING COLUMN

7. Put 1P808 General Purpose Lubricant on the bearing and in the cap.

8. Install tube assembly and bearing in cap (9).
Install the retainer ring that holds the bearing and tube assembly in the cap.

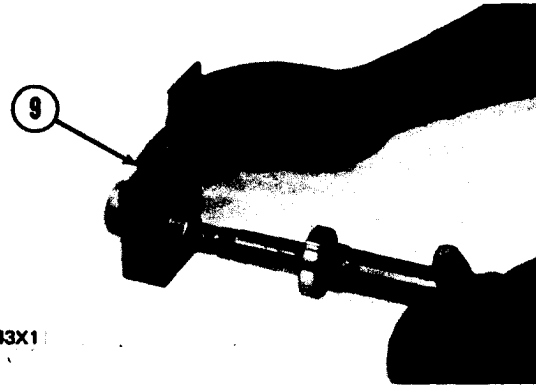

9. Put 1P808 General Purpose Lubricant on pin (12) and install the pin in the cap. Install retainer ring (11) on the pin.

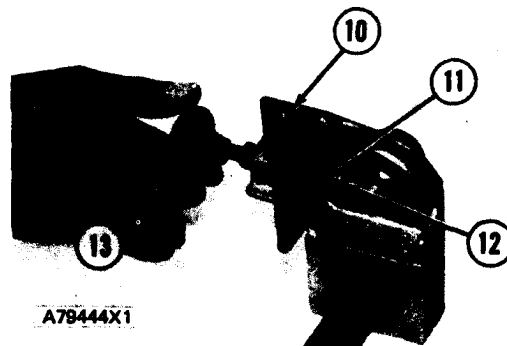

10. Install knob (13) and locknut on the pin.

11. Put 1P808 General Purpose Lubricant in the cap and install the detent ball and spring. Install set-screw (10) and tighten until detent ball is tight against the pin.

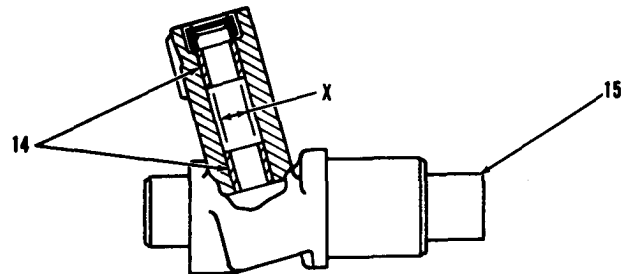

12. Install two bearings (14) in lever (15) with tooling (A). Install bearings so their outside edge is even with the counterbores of the lever. The inside diameter of the bearings after assembly must be $12.667 + 0.051$ or $- 0.013$ mm ($.4987 + .0020$ or $- .0005$ in.) (dimension x).

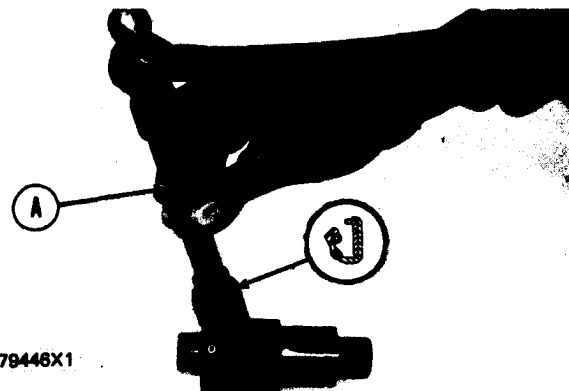

13. Install the lip seal in the lever with tooling (A).

ADJUSTABLE STEERING COLUMN

14. Install spacer (21) on the shaft.

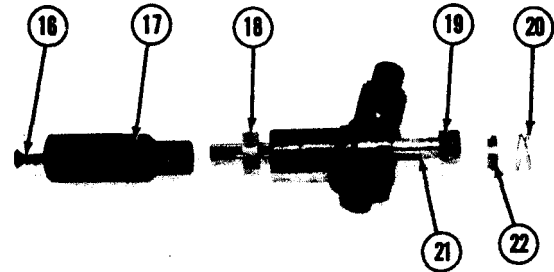

A79447X1

15. Put 1P808 General Purpose Lubricant on the shaft. Install shaft (19) in the lever.

16. Install retainer (22) and spiral lockring (20).

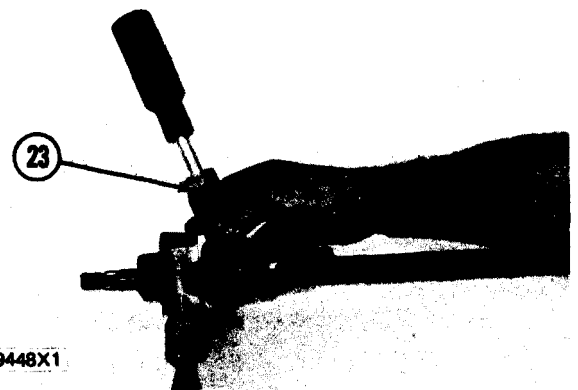

A79448X1

17. Install collar (18) on the shaft.

18. Install handle (17) on the shaft. Put 9S3263 Thread Lock on the screw threads and install screw (16) in the shaft.

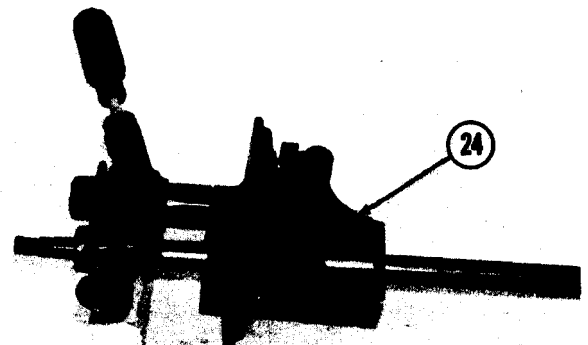

A79449X1

19. Put 1P808 General Purpose Lubricant in the cap. Install lever assembly (23) in the cap.

20. Put housing assembly (24) in position on the cap assembly. Install the four bolts that hold it. Make sure the bellcrank is at a right angle (perpendicular) to the tube assembly when the housing is installed.

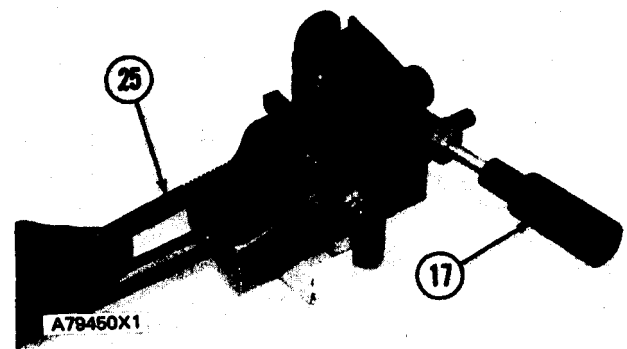

A79450X1

21. Put 1P808 General Purpose Lubricant on the rack. Install rack (25) into lever assembly as handle (17) is turned.

ADJUSTABLE STEERING COLUMN

22. Put column assembly (26) in position on the housing. Install plate (27) and bolt assembly. Install bolts that hold the tube assembly to the housing.
23. Put shaft (30) in position in lever (28). Install dowel (33) through the shaft.
24. Put 1P808 General Purpose Lubricant in the boss. Put spring (31) in boss (29). Put boss in position on support (32).
25. Put lever assembly in position on the support. Install dowel (34) through the support to hold lever.
26. Install steering column tilt lock (35) on bracket assembly.
27. Put bracket assembly (36) in position on the steering column support. Install the two nuts on the shaft of the column tilt lock.

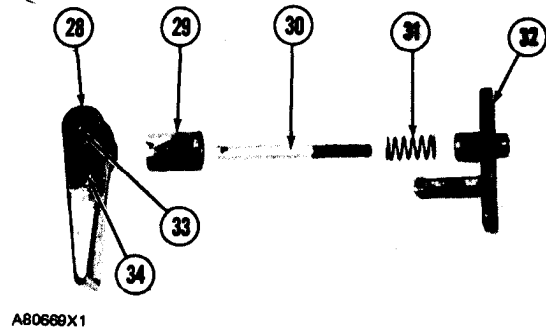
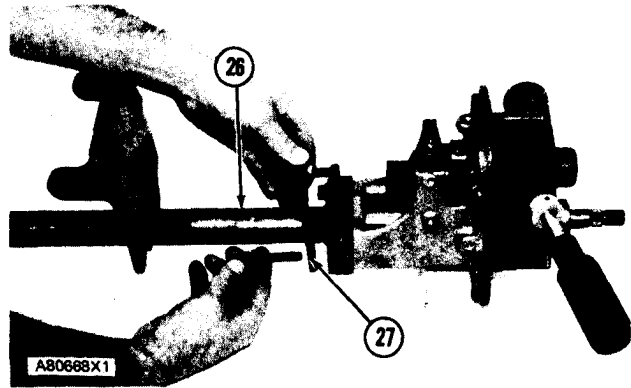

NOTE: When steering column is installed, make an adjustment to the nuts so the dimension between boss (29) and support (32) is 13 ± 1 mm ($.512 \pm .039$ in.).

28. Put steering wheel (37) in position on tube assembly, Install the nut and tighten to a torque of 50 ± 4 N.m (37 ± 3 lb. ft.).
29. Install cover (38) on the steering wheel.
end by:
a) install adjustable steering column

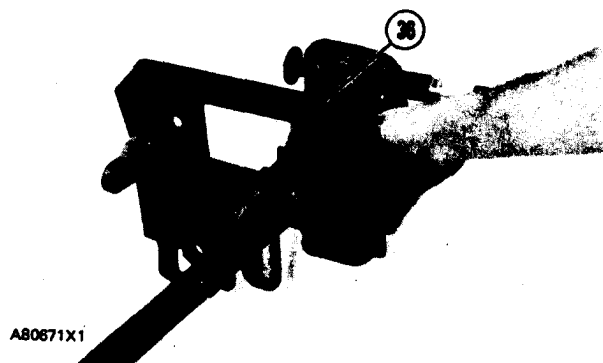
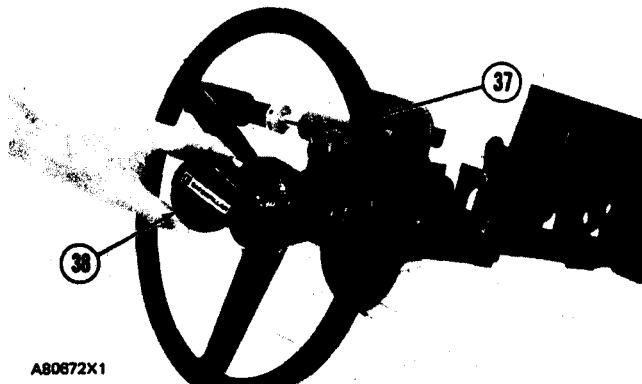
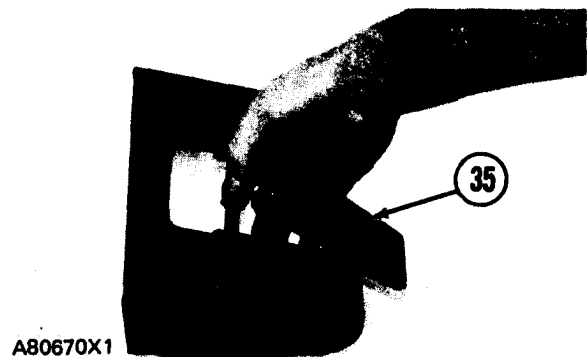

ROLLOVER PROTECTIVE STRUCTURE (ROPS)

REMOVE ROLLOVER PROTECTIVE STRUCTURE (ROPS)

7323-11

Tools Needed		A
6V2157	Link Bracket	3

1. Fasten a hoist to the top of ROPS (1) with tooling (A).
2. Remove bolts (2) and the spacers that hold each side of the ROPS to the machine.
3. Disconnect wire assemblies near bottom of right leg of ROPS.
4. Remove ROPS (1) from the machine. The weight of the ROPS is 563 kg (1250 lb.).

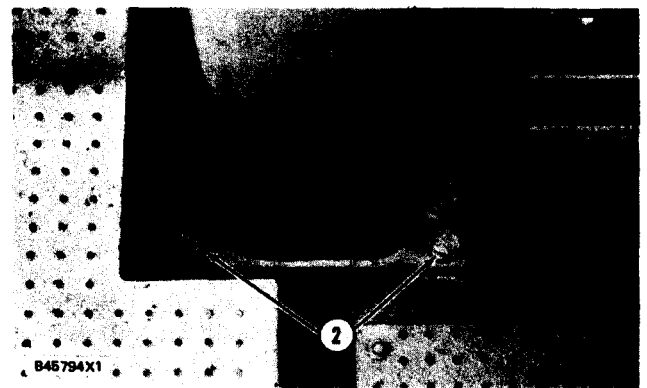
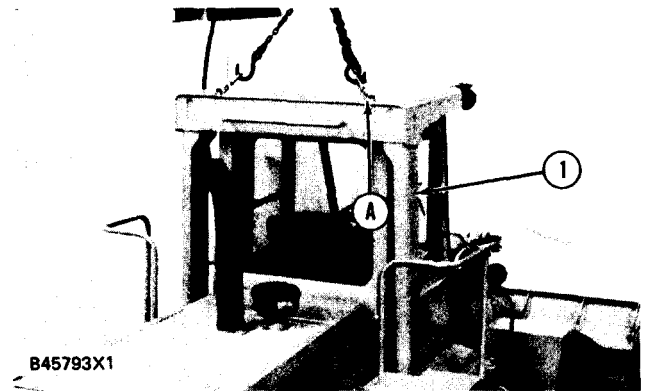

INSTALL ROLLOVER PROTECTIVE STRUCTURE (ROPS)

7323-12

Tools Needed		A
6V2157	Link Bracket	3

1. Fasten a hoist to the top of ROPS (1) with tooling (A) and put the unit in position on the machine.
2. Lower the ROPS and install the spacers and the bolts to each side. Tighten the bolts to a torque of $570 \pm 80 \text{ N}\cdot\text{m}$ ($420 \pm 60 \text{ lb}\cdot\text{ft}$).
3. Connect wire assemblies near bottom of right leg or ROPS.

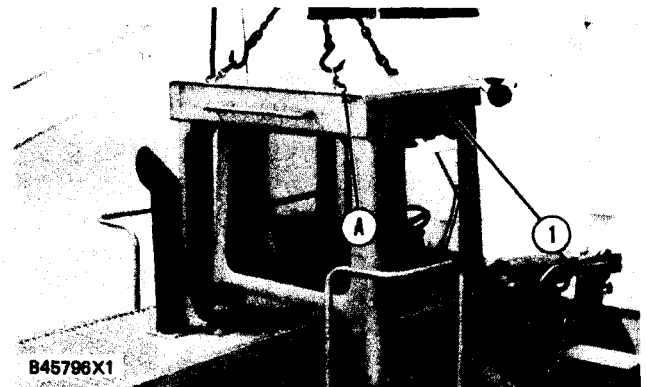

HYDRAULIC CONTROL GROUP

REMOVE HYDRAULIC CONTROL GROUP

5063-11

start by:

a) remove cab and platform

1. Remove springs (2) from lever (1) and bracket (3).

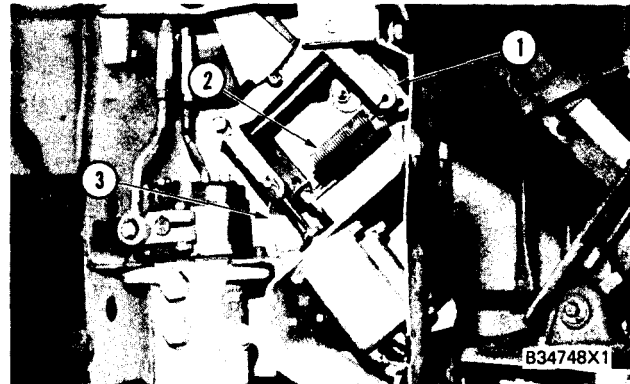

2. Disconnect hose assemblies (4) and (6) from the pilot valve(s).

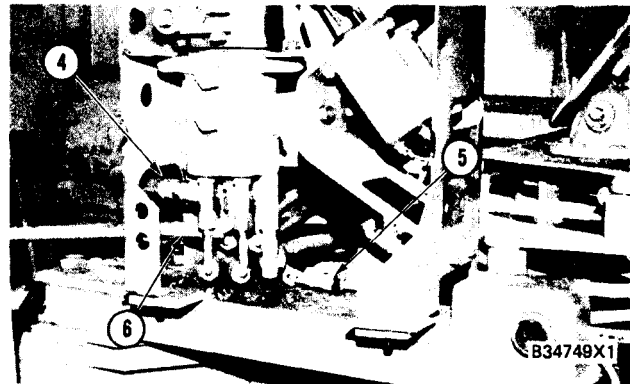

3. Disconnect wiring harness (5) from the solenoid wiring.

4. Loosen the bolts and nuts that hold levers (8) to the control shafts. Move levers (8) off the control shafts to disconnect the linkage from pilot valve(s) (9).

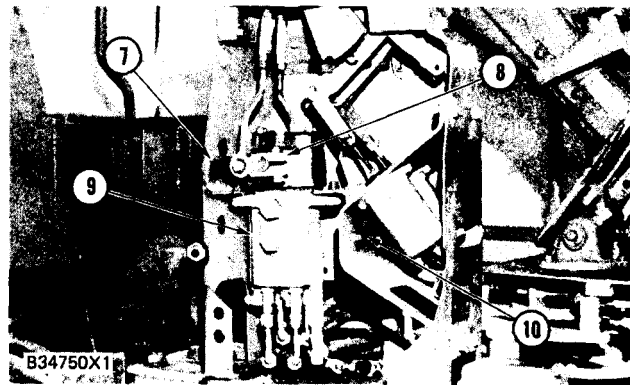

5. Remove the bolts (7) and bolts and nuts (10) that hold pilot valve(s) (10) in position.

6. Fasten a hoist to control group (11). Remove two bolts (12) and remove control group (11) from the machine. The weight of control group (11) is 20 kg (45 lb.).

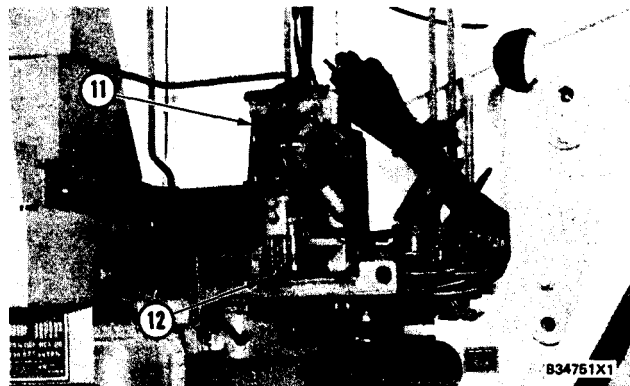

HYDRAULIC CONTROL GROUP**INSTALL HYDRAULIC CONTROL GROUP**

5083-12

1. Fasten a hoist and put control group (1) in position over the pilot valve(s).
2. Install the two bolts to hold control group (1) in the temporary storage position.
3. Move pilot valve(s) (4) in position and install the bolts and nuts to hold brackets (2) and (3) to the control group.
4. Connect the control linkages and levers (5) to the control shafts of the pilot valve(s).
5. Connect hose assemblies (6) and (8) to the bottom of the pilot valve(s). Connect wiring harness (7) to the solenoid wiring and install the bracket to hold the connection together.
6. Connect springs (9) to the bracket assembly and control linkage.
7. See **HYDRAULIC CONTROL LEVER LINKAGE ADJUSTMENT** in **SPECIFICATIONS** or **TESTING AND ADJUSTING** section for the correct adjustment of the hydraulic control group.
end by:
 - a) install cab and platform

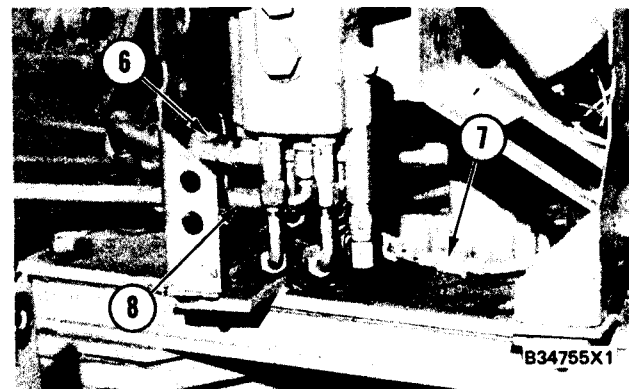
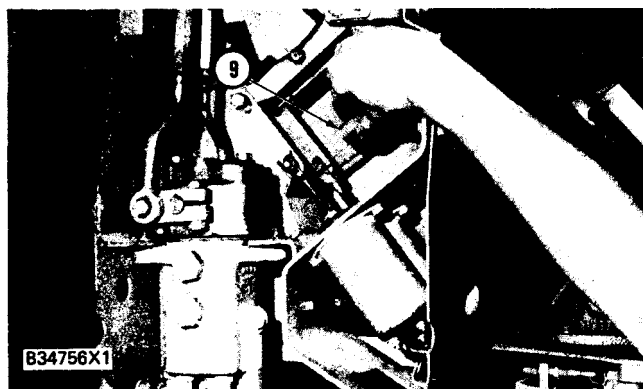
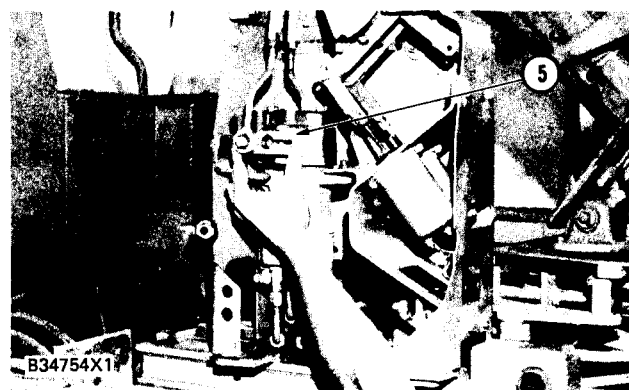
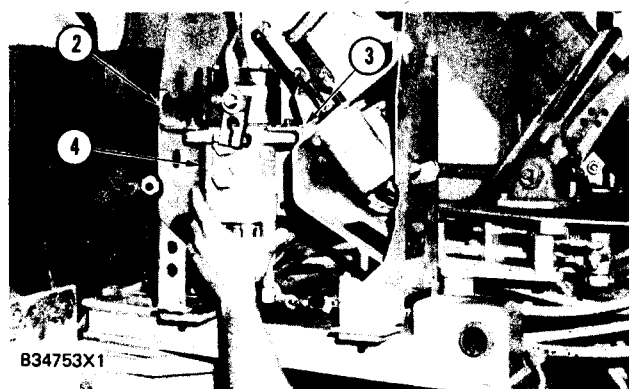
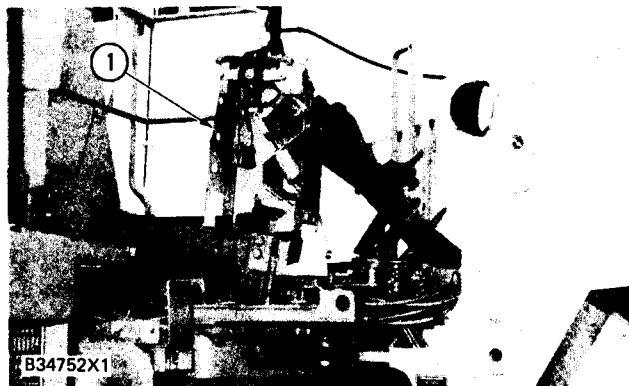

HYDRAULIC CONTROL GROUP

DISASSEMBLE HYDRAULIC CONTROL GROUP 5063-15

Tools Needed		A	B
1P510	Driver Group	1	
1P1859	Pliers		1

start by:

a) remove hydraulic control group

1. Remove the cotter pins and pins (1) to disconnect the solenoid rods from the links.
2. Remove bolts (2) and the washers to remove plate (3) with the solenoids from the control console.
3. Disconnect wiring harness (5) from the solenoids.
4. Remove bolts (4) and the washers to remove solenoids (6) from plate (3).
5. Loosen nut (7) and remove rod (8) from each of the solenoids.
6. Remove bolts (10) and (11), also the nuts and washers to make a separation of panel (9) from sheet assembly (12).

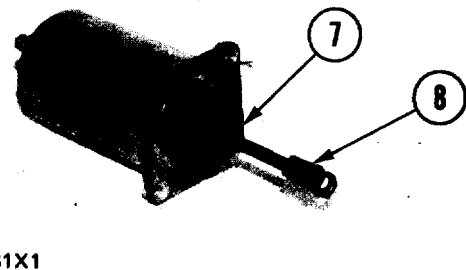
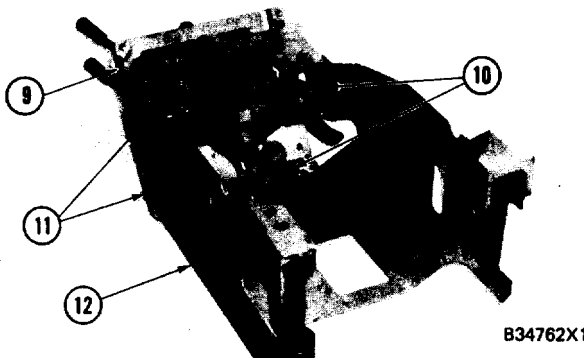
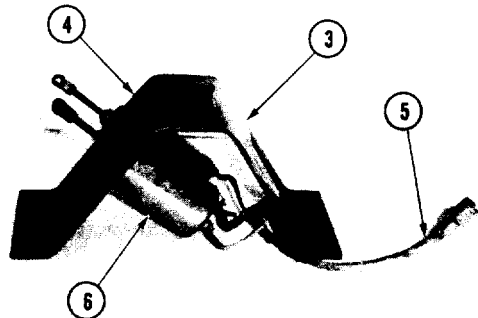
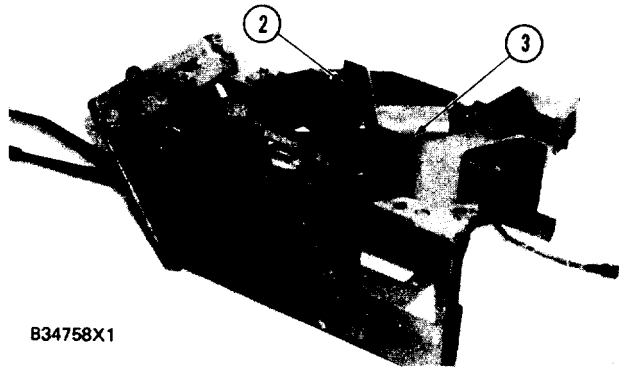
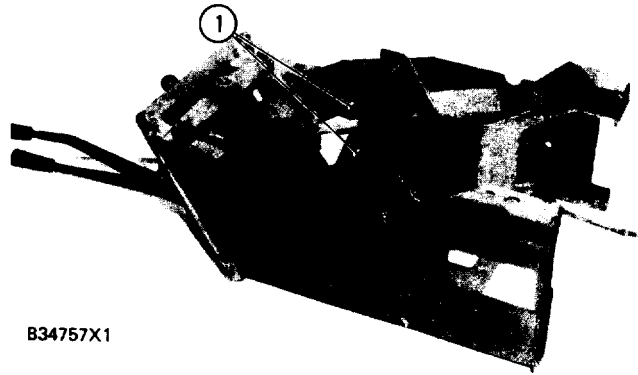

HYDRAULIC CONTROL

7. On models 950BNS and 950BS, loosen the setscrew and remove collar (14) from the shaft. Models 950BNSCE and 950BSCE do not use collar.
8. Remove two bolts (13), the washers and remove bracket (15) from the panel.
9. Remove bearing (16) from bracket (15) by hand.

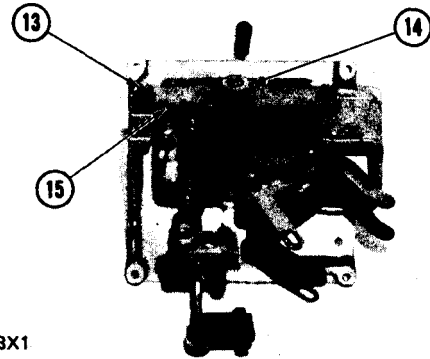

B34763X1

10. Remove bolt and washer (18) and shaft assembly (17) from panel (9).
11. Remove washer (19), lever (20), spacer (23) and bellcrank (21) from panel (9).
12. If necessary, remove the bolt and link (22) from lever (20). Remove the locknut and roller from lever (20).

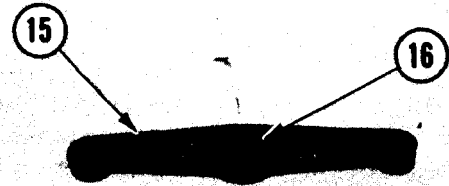

B34765X1

13. Remove the cotter pin, washer and pin to remove link (24) from bellcrank (21).
14. Remove the locknut and roller (25) from bellcrank (21).
15. Use tool group (A) and remove bearings (26) from bellcrank (21) and lever (20).

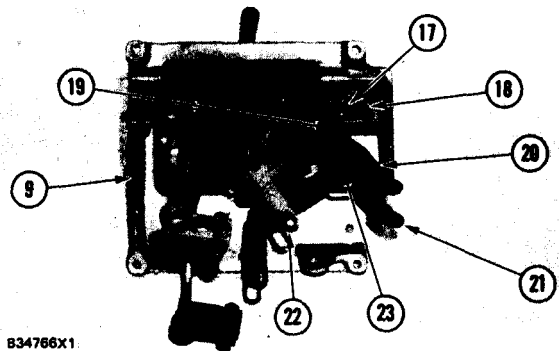

B34766X1

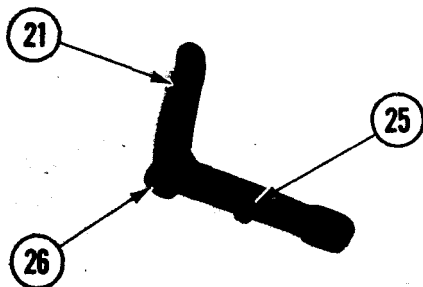

B34768X1

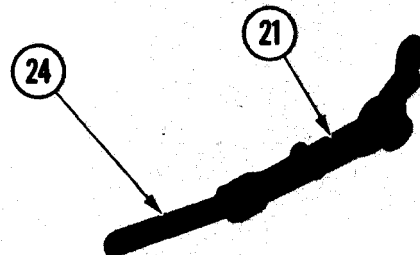

B34767X1

HYDRAULIC CONTROL GROUP

16. Loosen the locknut and bolt (27). Remove lever (29) and the control rod from the shaft of lever assembly (28).

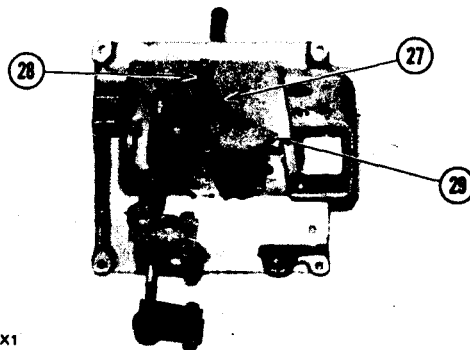

17. Remove the key from the shaft of lever assembly (28). Remove lever assembly (28) from the panel.

18. Remove bearing (31), the nut and knob (30) from lever assembly (28).

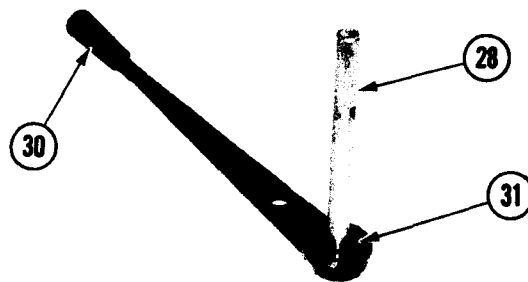

19. Loosen the locknut and bolt (33). Remove lever (34) and the control rod from the shaft of lever assembly (32).

20. Remove the two bolts and remove levers (34) and (35) from control rods (36).

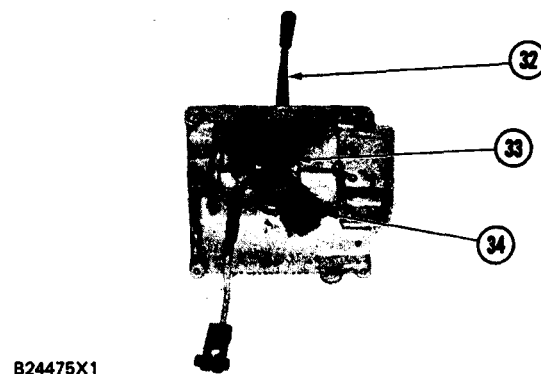

21. Loosen nuts (37) and remove rod end (39) and the nut from rod (38). Remove rod (38) and nut from rod (36).

22. Follow Steps 20 and 21 to disassemble the other control rod and lever (29).

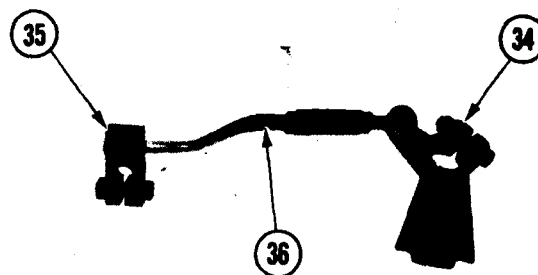
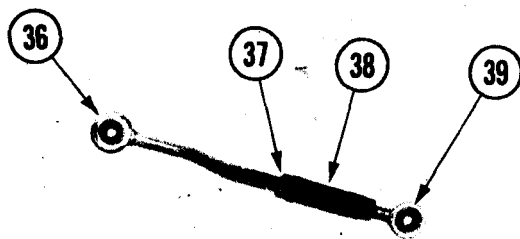

HYDRAULIC CONTROL GROUP

23. Use tool (B) and remove ring (40). Remove the bearing from over the shaft of lever assembly (32).

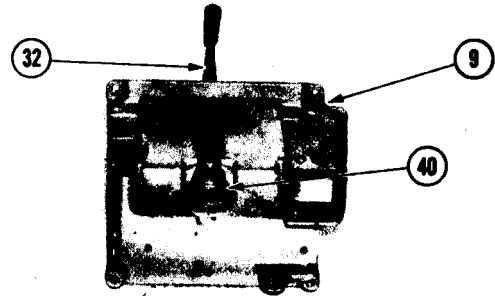

B24478X1

24. Remove lever assembly (32) from panel (9).

25. Remove key (43), bearing (44), two bearings (41) and knob (42) from lever assembly (32).

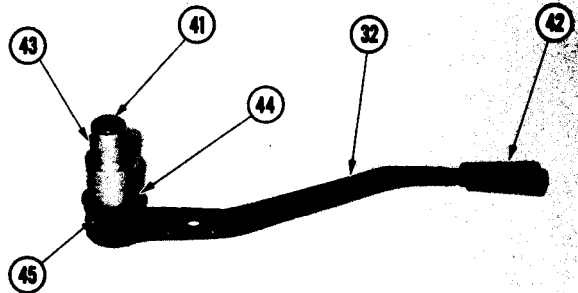

B24478X1

26. Use tool (B) to remove ring (45) from lever assembly (32).

NOTE: For the third attachment control lever in the hydraulic control group:

26a. Remove the bolts, nuts, washer and link from the end of the lever.

26b. Loosen clamp bolt on lever. Remove the lever and the key from the shaft of lever assembly.

26c. Remove lever assembly from the panel (9).

26d. Remove the knob and nut from the end of the lever assembly.

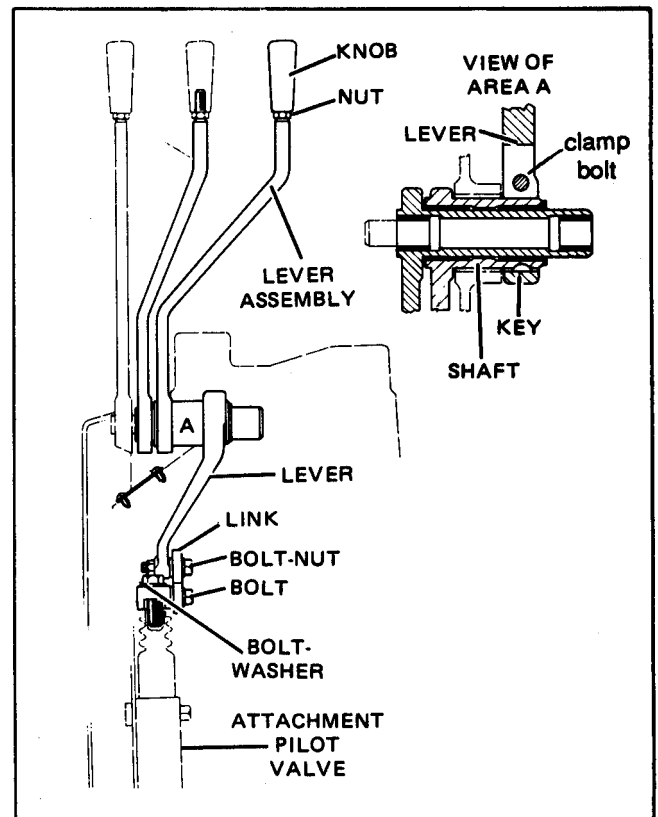

27. Remove screw (48), spring and detent ball from the panel.

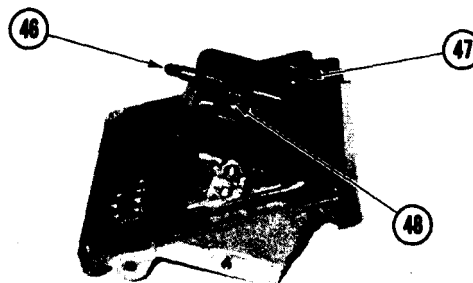

B24480X1

28. Loosen the screw on the opposite side and pull pin (46) out of the panel. Remove knob (47), the stud and locknut from pin (46).

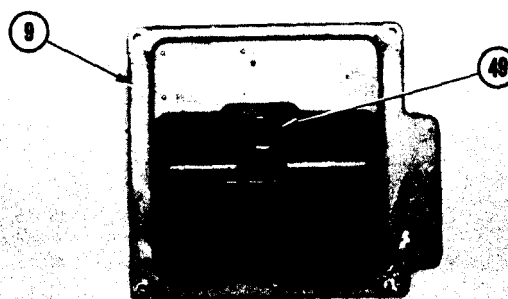

B24481X1

29. Remove bearing (49) from panel (9).

HYDRAULIC CONTROL GROUP

ASSEMBLE HYDRAULIC CONTROL GROUP

5063-16

Tools Needed		A	B
1P510	Driver Group	1	
1P1859	Pliers		1

1. Use tool group (A) to install the bearing in panel (1).
2. Install the knob, stud and locknut on pin (3).
3. Install pin (3) in the top of panel (1) as shown and tighten screw (2) to hold it.
4. Install detent ball (6), spring (5) and screw (4) in panel (1).

NOTE: For the third attachment control lever in the hydraulic control group: (See illustration accompanying steps 26a-d in the disassembly procedure of the hydraulic control group)

- 4a. Replace the knob and nut on the end of the lever assembly.
- 4b. Install the lever assembly in the panel.
- 4c. Install the key and lever on the shaft of the lever assembly. Tighten clamp bolt.
- 4d. Fasten the bolts, nuts, washer and link to the lever.

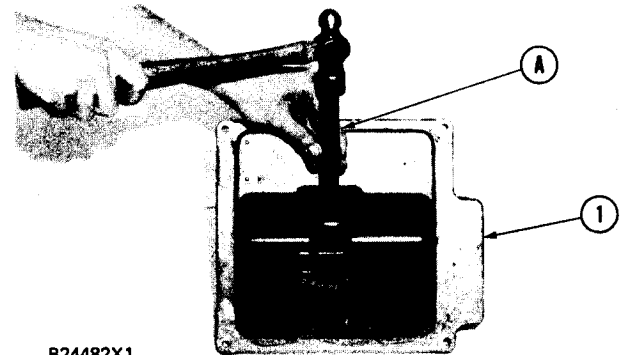

B24482X1

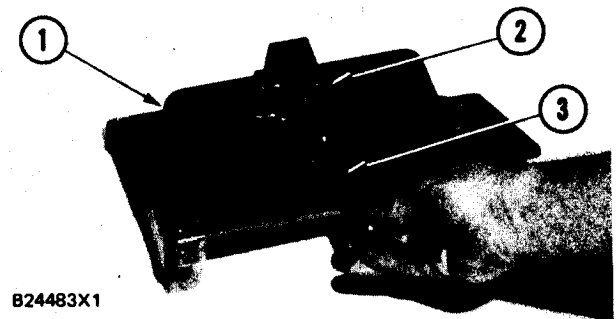

B24483X1

5. Use tool group (A) and install the bearings in each end of the shaft and lever assembly (7).

6. Use tool (B) to install the ring on the shaft of lever assembly (7).

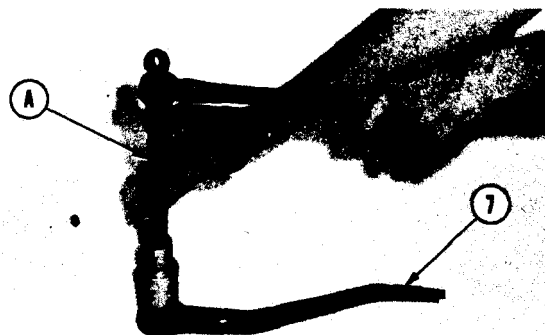
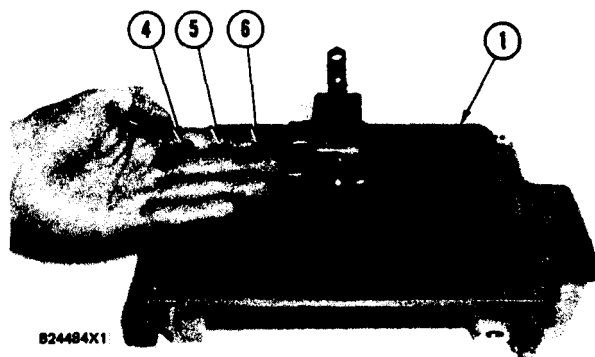

HYDRAULIC CONTROL GROUP

7. Install bearing (9) and knob (8) on lever assembly (7).

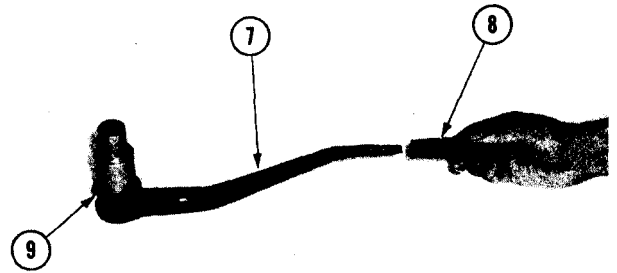

B24487X1

8. Install lever assembly (7) in panel (1).

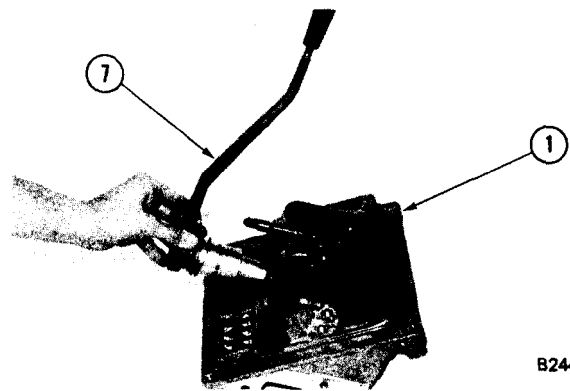

B24488X1

9. Install bearing (10) and use tool (B) to install ring (9) on the lever assembly.

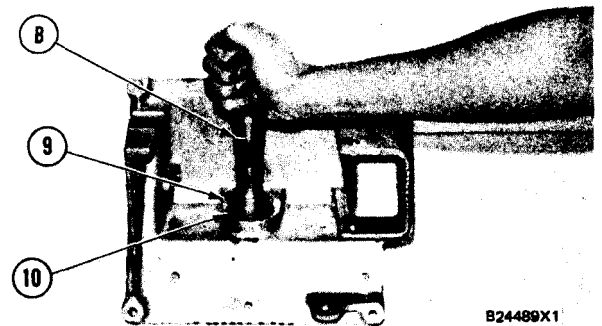

B24489X1

10. Install knob (11) and bearing (13) on lever assembly (12).

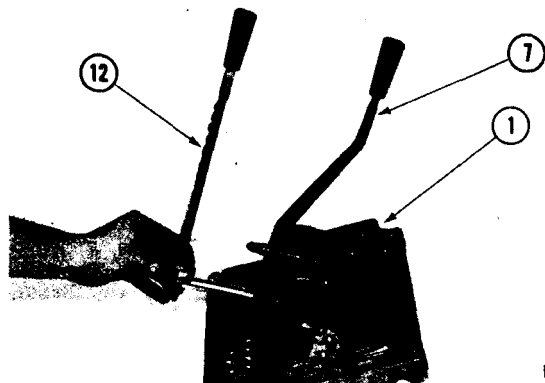

B24491X1

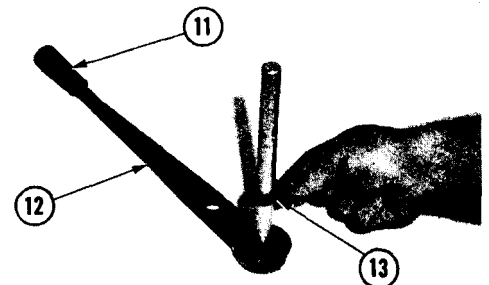

B24490X1

HYDRAULIC CONTROL GROUP

12. Install the nut, rod (17), nut and rod end (18) on rod (16). Before the nuts are tightened, turn the rod so the distance from center to center for the rod ends is 224 ± 1 mm (8.82 ± 0.04 in.).
13. Install the bolts to hold levers (14) and (15) to the rod ends.
14. Put the key for lever (15) in position and install rod (16) and lever (15) on the shaft of the lever assembly. Tighten the bolt and locknut.
15. Assemble control rod (20) and the levers as in Steps 12 and 13.
16. Put the key for lever (19) in position and install rod (20) and lever (19) on the shaft of the lever assembly. Tighten the bolt and locknut.
17. Use tool group (A) to install the bearings in bellcrank (21) and lever (22).
18. Install rollers (25) and the locknuts on the lever and bellcrank.
19. Put links (28) in position and install bolt (27) to hold a link to lever (22). Install pin (26) and the cotter pin to hold the link to bellcrank (21).
20. Put washer (24), bellcrank (21), spacer (23), lever (22) and the other washer in-position in the panel. Make sure the outside diameter of washers (24) are against the lever and bellcrank.

NOTE: On models 950BNSCE and 950BSCE, install two additional washers (38) on each side of spacer (23).

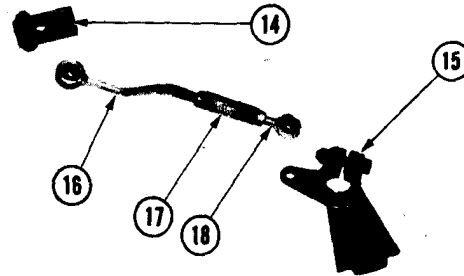

B24493X1

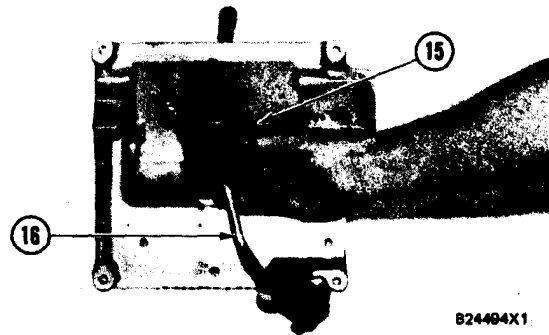

B24494X1

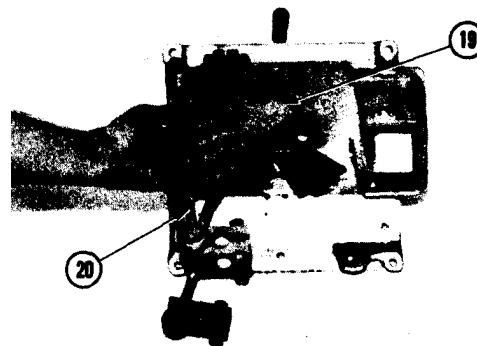

B24495X1

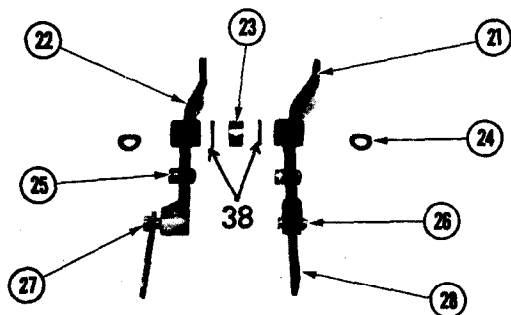

B24496X1

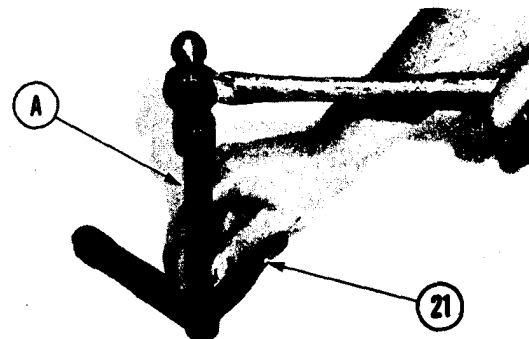

B24496X1

HYDRAULIC CONTROL GROUP

21. Install shaft assembly (29) to hold the bell-crank and lever in the panel. Install the bolt and washer to hold shaft assembly (29) in position.

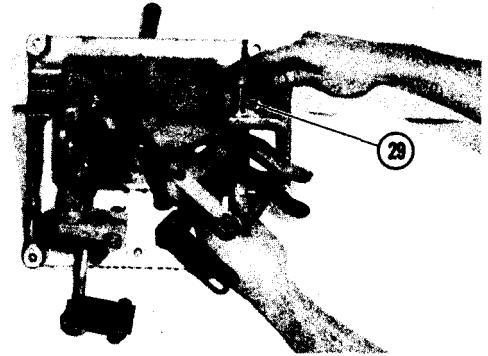

B24499X1

22. Install bearing (31) in bracket (30).

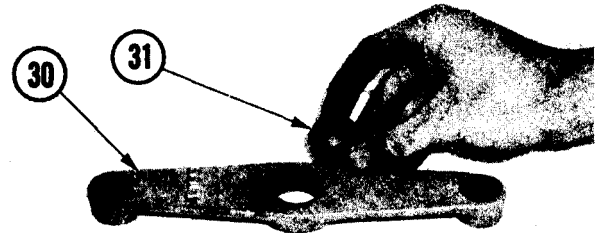

B24500X1

23. Install bracket (30) over the shaft of the lever assembly. Install the two washers and bolts to hold bracket (30) to the panel.

24. For models 950BNS and 950BS, install collar (32) on the shaft of the lever assembly and tighten the setscrew. Models 950BNSCE and 950BSCE do not use the collar and set screw.

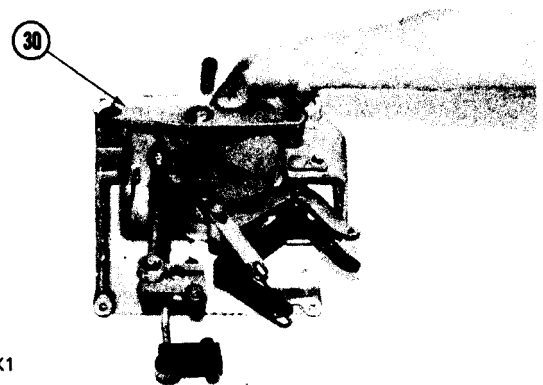

B24501X1

25. Put panel (1) in position in console (33) and install the four bolts and two nuts to hold the unit together.

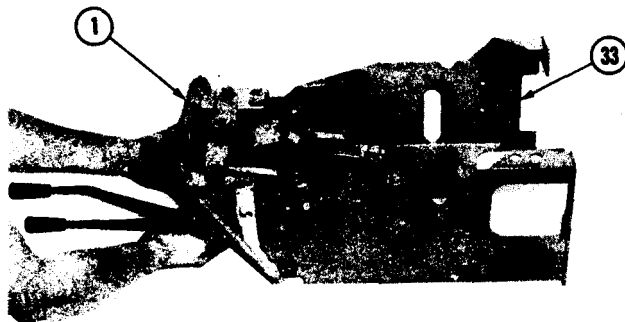

B24503X1

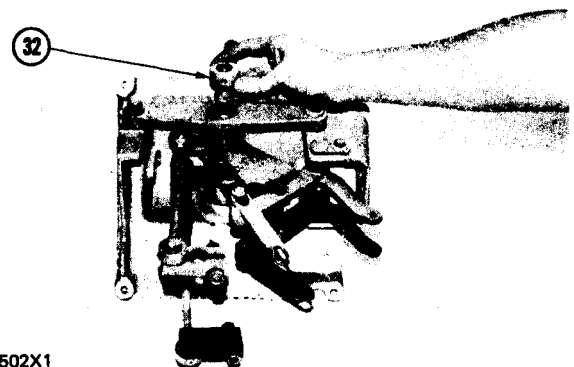

B24502X1

HYDRAULIC CONTROL GROUP

26. Install the nut and rod (35) on each solenoid (34).

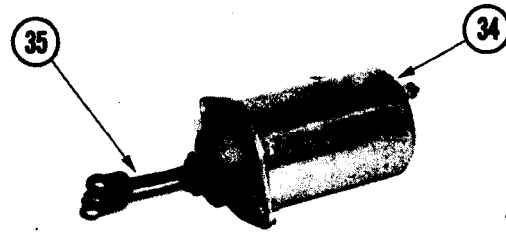

B24504X1

27. Put solenoids (34) in position and install the washers and bolts to hold them to plate (36).

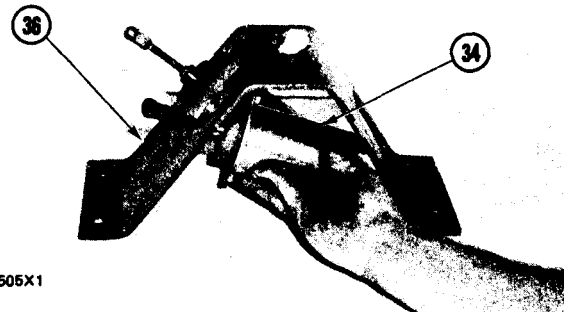

B24505X1

29. Put plate (36) in position and install the washers and bolts to hold it to console (33).

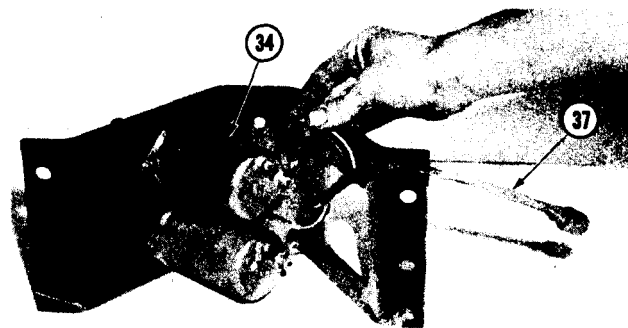

B24506X1

30. Install the pins and cotter pins to connect solenoid rods (35) to links (28).

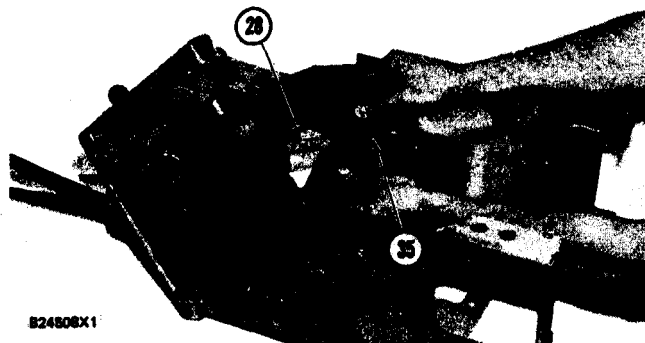

B24508X1

31. See HYDRAULIC CONTROL LEVER LINKAGE ADJUSTMENT in SPECIFICATIONS or TESTING AND ADJUSTING section for the correct adjustment of the hydraulic control group after it is installed.

end by:

a) install hydraulic control group

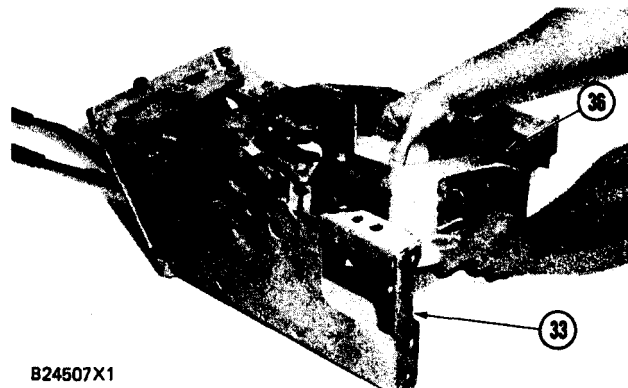

B24507X1

SUPPLEMENTAL OPERATING MAINTENANCE
AND REPAIR PARTS INSTRUCTIONS
FOR
LOADER, SCOOP TYPE, DED, 4 X 4,
ARTICULATED FRAME STEER,
2 1/2 CUBIC YARD BUCKET (CCE)
AIRBORNE/AIRMOBILE,
SECTIONALIZED AND NONSECTIONALIZED
MODEL 950BS; MODEL 950BSCE; MODEL 950BNS; MODEL 950BNSCE

TABLE OF CONTENTS

SECTION I	GENERAL	PARAGRAPH	PAGE
	Purpose	1-1	5-533
	Scope	1-2	5-533
	CCE Item	1-3	5-533
	Description	1-4	5-533
	Operational Concept	1-5	5-536
	Personnel and Training	1-6	5-537
	Logistics Assistance	1-7	5-537
	Error Reporting	1-8	5-537
SECTION II	MAINTENANCE		
	Maintenance Concept	2-1	5-538
	Maintenance Allocation Chart	2-2	5-538
	Modifications	2-3	5-539
	Equipment Improvement Recomm.	2-4	5-539
	Equipment Readiness Reporting	2-5	5-539
	Maintenance Expenditure Limits	2-6	5-539
	Shipment and Storage	2-7	5-539
	Destruction to Prevent Enemy Use	2-8	5-539

SECTION II	MAINTENANCE (cont.)		
	Fire Protection	2-9	5-539
	Basic Issue Items List	2-10	5-540
	Maintenance and Oper. Supply List	2-11	5-540
	Special Tools and Equipment	2-12	5-540
	Maintenance Forms and Records	2-13	5-540
SECTION III	REPAIR PARTS SUPPLY		5-541
	General	3-1	5-541
	Requisitioning Repair Parts	3-4	5-542
	Submitting Requisitions	3-5	5-542
SECTION IV	SAFETY	4-1	5-543
APPENDIXES			
A	Equipment Publications		A-1
B	Maintenance Allocation Chart		B-1
c	Modification Procedure		C-1
D	Basic Issue Items List		D-1
E	Sample Format, DA Form 2765, Request (P N)		E-1
F	Sample Format, Milstrip Request (NSN Manual)		F-1
G	Sample Format, Milstrip Requisition For (Non- NSN Manual)		G-1
H	Sample Format, Non-NSN Requisition (Manual) DD Form 1348-6		H-1
I	Maintenance and Operating Supply List		I-1
J	Preventive Maintenance Checks & Services		J-1
K	Shipping Instructions		K-1

SECTION I

GENERAL

1-1 Purpose To provide user and support and personnel supplemental maintenance and repair parts instructions that have special application to Commercial Construction Equipment (CCE) items.

1-2 Scope. This section applies to department of the Army Units, Organizations and Activities that use\or support the CCE Scoop Loader, Caterpillar Model 950B.

1-3 CCE Item. The term "CCE Item" used in this publication applies to a standard commercial item of commercial equipment that has been approved for a specific TOE requirement and is procured and supported under the CCE system plan. This plan permits maximum utilization of the civilian construction industry's competitive research and development, manufacturer's equipment publications, and commercial sources for repair parts.

1-4 Description:

A. This loader is a commercial 2 1/2 cubic yard capacity loader, scoop type, DED 4 x 4 articulated frame steering. The loader is a Caterpillar Tractor Co. Model 950B front end scoop loader that is rubber tire mounted. When equipped with the 2 1/2 cubic yard multi-purpose bucket, non-sectionalized, it is referred to as the Type I Loader, Models 950BNS and 950BNSCE. When equipped with a 2 1/2 cubic yard multi-purpose bucket, sectionalized, it is referred to as the Type II Loader, Models 950BS and 950BSCE. The Loader will be identified by the CCE manufacturer's serial number and the United States Army (USA) number. The NSNS for the Type I machines are, Model 950BNS NSN 3805-01-126-7914, Model 950BNSCE NSN 3805-01-260-5163. The NSNS for the Type II machines are, Model 950BS NSN 3805-01-126-7915, Model 950BSCE NSN 3805-01-260-5162.

B. The Loader is powered by a Caterpillar 3304 engine which develops 155 HP (2200 RPM) at the flywheel. The power train consists of a single stage torque converter and planetary power shift transmission. The Torque Converter drives a planetary transmission. The transmission has four speeds FORWARD and four speeds REVERSE. It has a planetary gear system and six hydraulic clutches. The gear on the transmission output shaft is engaged with the transfer output shaft gear to send power through universal joints to the drive shafts. The drive shafts are connected with splines to a pinion shaft in each differential. The pinion shaft turns a bevel gear which is fastened to the differential case. The differential case contains four pinions, installed on a spider and two gears. The four pinions are engaged at right angles with two side gears. The side gears are connected with splines to the inner ends of the the drive axles.

C. The differential makes the torque equal at both drive wheels. When one wheel turns slower than the other, as in a turn, the differential permits the wheel to stop or turn slower in relation to the outside wheel. When the machine moves straight ahead with equal traction under each drive wheel equal torque on each axle stops pinions so they will not return on the spider. This gives the same action as if both drive wheels were locked on the same driving axle when unequal loads are put on the drive wheel, as in a turn, forces that are not equal are put on opposite sides of the differential and cause the pinions to turn. As the pinions turn, the inside wheel turns slow or stops the rotation of the outside wheel increases. This action causes the machine to be driven with full power in a turn.

D. The final drive has hydraulic disc brakes. Hydraulic disc brakes requires no adjustment. The lining maintains light contact with the discs to keep them clean.

E. The final drive is operated by a planetary gear system. The axles are connected to the differential at one end and to sun gear at the other end by splines. The ring gear of the planetary system is connected to the hub splines. The hub is connected to spindle by splines. The splines are fastened to axle housing.

F. The brake system is an air over hydraulic type. An engine driven compressor supplies compressed air for the system. The compressed air is stored in the air reservoir. The output is regulated by a governor between the compressor and the reservoir at 85 to 100 psi. The hydraulic system is a closed system with contracted pressure relief. The loader has a maximum speed of 22.6 mph (36.4 km/h). The fuel tank capacity is 57.7 gallons (218L) and the equipment will use approximately 48 - 60 gallons (148L) diesel fuel with the engine operating at 2100 rpm, for a period of 8 hours (steady cycling on the basic loader cycle). Since the vehicle cannot travel at a speed greater than 25 mph, insure that a slow moving emblem, NSN 9905-01-045-2201, is mounted on the rear of the vehicle whenever the vehicle is driven public highways.

G. Dimensions and other pertinent data.

1. Height Overall (Maximum) - 201 inches (5.1m)
2. Height, Top of ROPS - 136.8 inches (3.47m)
3. Height, Top of Stack - 126.8 inches (3.22m)
4. Height, Sectionalized Configuration - 90 inches (2.31m)
5. Height, Hinge Pin at Full Tilt - 153.5 inches (3.91m)

6. Height, Dumping to Cutting Edge at Full Tilt - 114 inches (2.9m)
7. Length, Overall (Maximum) - 296.6 inches (7.59m)
8. Length, Drive on Configuration (With Trailer) - 343.4 inches (8.72m)
9. Length, Sectionalized Configuration (Power Section) - 157.9 inches (4.01m)
10. Length, Sectionalized Configuration (Bucket Section) - 171.7 inches (4.36m)
11. Wheel Base - 125.2 inches (3.18m)
12. Width, Overall (Maximum) - 106 inches (2.68m)
13. Center of Gravity, Non-Sectionalized (From Rear Bumper Forward) - 144.1 inches (3.66m)
14. Center of Gravity, Sectionalized (Power Section, (From Rear Bumper Forward) 77.9 inches (1.98m)
15. Center of Gravity, Sectionalized (Bucket Section, From Front Bucket Back) 87.7 inches (2.23)
16. Reach, Measured to Cutting Edge, Full Tilt and 45' Dump Angle (minimum) - 41 inches (1.04m)
17. Roll Back at Carry Height (Maximum) - 48 inches (1.22m)
18. Digging Depth (Maximum) -3.5 inches (75mm)
19. Hydraulic cycle time, rated load in bucket:
 - Raise - 6.6 seconds
 - Dump - 2.2 seconds
 - Lower (empty) - 3.0 seconds
 - Total - 11.8 seconds
20. Turning radius (minimum) -250.3 inches (2.67m)
21. Clearance circle (bucket in carry position) - 540 inches (13.74m)

H. The loader is equipped with:

Bucket: Multi-purpose bucket with an SAE nominal heaped rating of 2.5 cu yds (2.4m) and straight cutting edge. Measured width of bucket is 106 inches (2.68m).

Steering System: Articulated frame steering system turns short, has long wheel base for loading stability. Hinge point is mid-way between front and rear axles, so rear wheels track the front.

Tires: All tires are traction type (L-2), nylon, tubeless, 20.5 x 25., and are rated at 12 ply. Tires are inflated to 50 psi (3,45 kpa). Sufficient clearance is provided to mount the L-2 type tires without removal of any components.

Electrical System: The loader has a 24 volt electrical starting and lighting system with necessary fuses and circuit breakers. All control switches are located on the dash within reach of the operator. The system has a negative ground circuit.

Alternator: The loader is equipped with a Delco-Remy engine driven alternator and compatible regulator self-contained. The alternator is 24 volts with 50 amp rating.

Instruments: The loader is equipped with waterproof gauges and switches. The gauges are illuminated by rear lighting and identified on the instrument panel. The following instruments are on the panel:

1. Air pressure gauge - light (EMS system)
2. Service meter gauge
- 30 Engine oil pressure gauge - light (EMS system)
4. Water temperature gauge - light (EMS system)
5. Ammeter gauge - light (EMS system)
6. Torque converter oil temperature gauge - light (EMS system)

Battery: Two (2) 12 volt batteries are installed in series to provide 24 volts for the starting system. Batteries are located in the rear bumper on each side of the machine. Service checks can be performed easily and quickly from ground level.

Oil Sampling Valves: An oil sampling valve will be supplied on the engine and transmission for use in the Army Oil Analysis Program. Samples should be taken IAW TB 43-0210. Stenciled markings above the valves identify the locations of the valve and the component from which oil is being sampled.

1-5. Operation Concept. The 2 1/2 cubic yard Scoop Loader is to be used by engineer construction units equipped with Commercial Construction Equipment (CCE). This Scoop Loader will be used to excavate and load consolidated earth, blast rock, loose or decomposed rock, sand, aggregate and loose.. soil from stock piles into dump trucks, concrete mobile mixers, hoppers and aggregate bins.

1-6. Personnel and Training.

A. MOS requirements.

1. Operator: Heavy construction equipment operator,
MOS 62B20
2. Organizational: Construction equipment repairer,
MOS 62B30.

B. New Equipment Training: New Equipment Training Teams (NETTS) are available to major field commands. Request for NETTS should be forwarded to Commander, US Army Tank-Automotive Command (TACOM), ATTN: AMSTA-MLT, Warren, MI 48397-5000. Training teams should be requested only when trained personnel are not available in the command to operate and/or maintain the Scoop Loader.

1-7. Logistics Assistance (AR 700-4). US Army Tank-Automotive Command's Logistics Assistance Representatives (LAR) stationed at CONUS/OCONUS installations are available to furnish on site training and/or technical assistance. When training or technical assistance is required, contact the appropriate Logistics Assistance Office (LAO) listed in Appendix B of AR 700-4.

1-8. Error Reporting. You can improve this publication by recommending improvements, using DA Form 2028 (recommended Changes to Publications and Blank Forms) and mail direct to Commander, US Army Tank-Automotive Command (TACOM), ATTN: AMSTA-MBS, Warren, MI 48397-5000.

SECTION II
MAINTENANCE

2-1. Maintenance Concept. The Loader will not require any new or special maintenance considerations. All maintenance functions can be accomplished within the current maintenance concepts established for construction equipment.

A. Operator/Crew Maintenance: Operator/Crew Maintenance consists of daily checks, servicing and adjustments to obtain and maintain a specific mission profile. Repair by operator/crew is limited to minor adjustments which do not require disassembly.

B. Organizational Maintenance: Organizational maintenance will be accomplished by adjusting or replacing accessible parts, assemblies and modules. A module is an item assembly or component. Organizational maintenance is designed to be handled as a single unit to facilitate supply and/or maintenance which does not require disassembly, special tools or test equipment.

c. Direct Support Maintenance:

1. Direct Support Maintenance provides quick response to "on equipment" repairs consisting of complete adjustment and replacement of designated parts. Assemblies and modules to return the item to operation ready status.

2. Direct support maintenance performs "off equipment" repair to designated assembled modules and replaces special kits and authorized piece parts.

D. General Support Maintenance: General support maintenance repairs and returns to the supply system designated assembled modules which overflow from or exceed the capability of direct support maintenance. General support maintenance performs limited piece part repair and overhaul of selected major assemblies or components designated by the area support command for return to stock.

E. Depot Maintenance: Depot maintenance overhauls end items and selected major assemblies when they are required to satisfy overall Army requirements. Overhaul of the end item may also be performed by contract with manufacturer.

2-2. Maintenance Allocation Chart. Maintenance will be performed as necessary by the category indicated in the Maintenance Allocation Chart (MAC) to retain or restore serviceability. All authorized maintenance within the capability of a using organization will be accomplished before referring the item to support maintenance. Higher categories will perform the

maintenance functions of lower categories when required or directed by the appropriate commanders. Using and support units may exceed their authorized scope and functions in the MAC when approval is granted by the next higher support maintenance commander.

2-3. Modifications. Modifications will be accomplished by the loader manufacturer after TACOM approves the field campaign or modification plan. See Appendix B.

2-4. Equipment Improvement Recommendations (EIR). Equipment Improvement Recommendations (EIR)/Quality Deficiency Reports (QDR) will be submitted in accordance with DA PAM 738-750.

2-5. Equipment Readiness Reporting. Readiness Reporting will be accomplished as required by current DA PAM 738-750.

2-6. Maintenance Expenditure Limits. The average life expectancy for the Loader is 15 years.

PERCENT OF REPAIR:			PERCENT OF REPAIR:		
MODELS			MODELS		
950BSCE AND 950BNSCE			950BS AND 950BNS		
60%	thru	1996	60%	thru	1990
53%		1997	53%		1991
45%		1998	45%		1992
38%		1999	38%		1993
30%		2000	30%		1994

After last date use 25% repair limit until type classified obsolete.

2-7. Shipment and Storage.

A. Shipment and Storage. Refer to TB 740-97-2 for procedures covering preservation of equipment for shipment and storage.

B. Administrative storage. Refer to TM 740-90-1 for instructions covering administrative storage of equipment.

2-8. Destruction to Prevent Enemy Use. Refer to TM 750-244-3 for procedures covering destruction of equipment to prevent enemy use.

2-9. Fire Protection:

A. A hand operated fire extinguisher may be installed at the discretion of the using unit.

Approved hand-portable fire extinguishers are listed in TB 5-4200-200-10.

2-10. Basic Issue Items List (BIIL). See Appendix C for items which accompany the end item or are required for operation and/or operator's maintenance.

2-11. Maintenance and Operating Supply List. See Appendix I for a list of maintenance and operating supplies required for initial operation.

2-12. Special Tools and Test Equipment. No special tools or test equipment are required for operation and maintenance of the loader.

2-13. Maintenance Forms and Records. Operational Maintenance and Historical records will be maintained as required by the current DA PAM 738-750.

SECTION III
REPAIR PARTS SUPPLY

3-1. General:

A. The basic policies and procedures in AR 710-2, AR 725-50 and DA CIRC 700-27 are generally applicable to repair parts management for CCE items.

B. Manufacturer's parts manuals are furnished with CCE Items instead of Department of Army Repair Parts and Special Tools List (RPSTL).

C. National Stock Numbers (NSN) are initially assigned only to mission essential and major assemblies/parts, ie., engines, transmissions, etc... Additional NSNS are assigned by the supply support activities as demand warrants.

D. Automated processing (AUTODIN) of Contractor And Government Entity (CAGE) (Previously known as Federal Supply Code for Manufacturers (FSCM)) part number requisitioning, without edit for matching NSNS and exception data, is authorized.

E. Proper use of project codes and weapon system designator codes on parts requisitions is essential.

Repair parts are available from commercial sources and may be purchased locally in accordance with AR 734-110 and AR 710-2.

G. Any questions or problems with ordering parts should be brought to the attention of the U.S. Tank-Automotive Command, ATTN: AMSTA-MB, Warren, Mi 48397-5000.

3-4. Requisitioning Repair Parts.

A. Using Units/Organization: Requisition (DA Form 2765 Series) will be prepared according to AR 710-2 and local command directives. Units in CONUS will use project code "BGW" in Block 19. Units OCONUS will enter in 19 project code "JZC", See Appendix H.

B. Support Units and Activities:

1. General: All MILSTRIP requisitions (DD Form 1348 Series) prepared for repair parts support will include distribution and project codes, See Appendixes G, H, and I.

2. Distribution Code: Supply customers in CONUS will code 'F' in card column 54. Customers OCONUS will use the appropriate code from Appendix P, paragraph p-3, AR 725.50.

3. Project codes: The applicable project code will be entered in card columns 57-59 of requisitions for NSN parts, whether CONUS or OCONUS customers. Project code "BGW:" will be used by CONUS customers when requisitioning part numbered parts. Supply customers OCONUS will use project code "JZC" for part numbered parts.

3-5. Submitting Requisitions:

A. Using units and organization will submit DA Form 2765 Series requisitions to designated support units or activities in accordance with local procedures.

B. Support units and activities will forward MILSTRIP requisitions for NSN parts through the Defense Automated Addressing System (DAAS) to the managing supply support activity. Requisitions for part numbered parts will be forwarded through DAAS to the Defense Construction Supply Center (DCSC).

NOTE : When the manufacturer's part number and Federal Supply Code for Manufacturers (FSCM) exceed the space in card column 8 through 22 of A02/AOB requisitions, prepare an A05/AOE requisition (DD Form 1348-6) and mail it to: Commander, Defense Construction Supply Center, ATTN: DCSC-OSR, Columbus, Ohio 43215.

SECTION IV

SAFETY

4-1. Only licensed operators are permitted to operate this equipment. All operators of construction equipment will be instructed to safely operate this type of equipment in accordance with the operators manual, TB 385-8, and the Occupational Safety and Health Standards Parts 1910 and 1926 as applicable.

4-2. This section is designed to help prevent accidents, injuries, and damage to property through a recognized effort to ensure the application of safety standards and the development of safe operating procedures.

4-3. Before operator begins work, he will familiarize himself/herself with the immediate working site and surrounding area, determine number and location of co-workers, and stay alert at all times as to their whereabouts. Further, if hand signals must be used, only one person will give hand signals to the operator. Warning, this is a one-person vehicle. No riders allowed.

4-4. Always lower scoop to the ground or securely block any moving hydraulic assemblies on vehicle before performing any inspections? services, or adjustments. Make sure vehicle is in "OFF" position.

4-5. Although this vehicle is designed with a transmission high range forward speed of 22.6 mph, seldom, if ever, should it be required to travel at this maximum speed. During normal operations, speeds should be limited to 5 mph loaded and 15 mph empty. In all cases, the operator should determine the safe speeds for operation using climatic, terrain, and area of work site conditions as the determining factors. Since the vehicle cannot travel at a speed greater than 25 mph, insure that a slow moving vehicle emblem, NSN 9905-01-045-2201, is mounted on the rear of the vehicle whenever the vehicle is driven on public highways.

4-6. Proper supervision of all construction equipment must be of paramount importance to assure safe operation.

4-7. Operators will check the condition of their equipment. The operator will have the responsibility to decline operating a vehicle, which in their opinion is not safe to operate, until declared safe by a qualified inspector.

4-8. Operators will immediately report all defects in the equipment to their supervisor. The supervisor has the responsibility to report defective equipment and deadline, if necessary, until corrective action has been taken.

4-9. Operators will not smoke, eat, read, or otherwise divert their attention while operating equipment.

4-10. Construction equipment is designed to save time and labor. The volume of material which can be handled by this type of equipment is dependent upon the skill of the operator and the load capacity of the vehicle. Competent and trained operators strive to avoid wasted effort, damaging of supplies, safeguard equipment? and prevent accidents of any type.

4-11. There will be no unauthorized attachments used on any TACOM construction equipment.

4-12. NOTE: DURING OPERATION:

Operation of this equipment presents a noise hazard to personnel in the area. The noise level exceeds the allowable limits for unprotected personnel. Wear ear muffs or plugs which were fitted by a trained professional.

4-13. NOTE: The back-up alarm should sound when the transmission direction lever is placed in reverse (R).

APPENDIX A

REFERENCES

A-1. SCOPE

This appendix lists all forms and publications pertinent to the major item material and associated equipment.

A-2. PUBLICATIONS INDEX

The following index should be consulted frequently for latest changes or revisions and for new publications relating to material covered in this manual.

DA PAM 310-1	Consolidated Index of Army Publications and Forms
DA PAM 310-10	Index of Army Equipment Modification Work Orders

A-3 . FORMS

DA Form 2028	Recommended Changes to Publications and Blank Forms
DA Form 2028-2	Recommended Changes to Equipment Technical Publications
DA Form 2401	Organizational Control Record for Equipment
DA Form 2402	Exchange Tag
DA Form 2404	Equipment Inspection and Maintenance Work Sheet
DA Form 2405	Maintenance Request Register
DA Form 2406	Material Condition Status Report
DA Form 2407	Maintenance Request
DA Form 2407-1	Maintenance Request - Continuation Sheet
DA Form 2408	Equipment Log Assembly (Records)
DA Form 2408-9	Equipment Control Record
DA Form 2408-10	Equipment Component Register
DA Form 2408-2(3)	Oil Analysis Log
DA Form 2409	Equipment Maintenance Log - (Consolidated)
DA Form 285	U.S. Army Accident Investigation Report
DA Form 348	Equipment Operator's Qualification Record (Except Aircraft)
DD Form 314	Preventive Maintenance Schedule and Record
DD Form 518	Accident - Identification Card
DD Form 1397	Processing and Reprocessing Record for Shipment, Storage, and Issue of Vehicles
DA Form 2026	Oil Analysis Record
SF 46	U.S. Government Motor Vehicle Operator's Identification Card
SF 91	Operator Report on Motor Vehicle Accidents
SF 368	Quality Deficiency Report

APPENDIX A

A-4 . FIELD MANUALS

FM 9-207 Operation and Maintenance of Ordnance
Material in Cold Weather (0 Deg to Minus
65 Deg)

FM 20 Camouflage

FM 21-11 First Aid for Soldiers

FM 21-40 NBC (Nuclear, Biological, and Chemical)
Defense

FM 21-305 Manual for Wheeled Vehicle Driver

FM 31-70 Basic Cold Weather Manual

FM 31-71 Northern Operations

FM 43-2 Metal, Body Repair

FM 90-3 Desert Operations

FM 90-5 Jungle Operations

A-5. TECHHICAL MANUALS

TM 3-220 Chemical, Biological, and Radiological
(CBR) Decontamination

TM 3-4230-204-12&P Decontaminating Apparatus Maintenance

TM 3-6665-225-12 Chemical Agent Alarm Maintenance

TM 5-200 Camouflage, Field Manufacturing Techniques

TM 9-214 Inspection, Care, and Maintenance of
Antifriction Bearings

TM 9-237 Welding Theory and Application

TM 9-238 Deep Water Fording of Ordnance Material

TM 9-243 Use and Care of Hand Tools and Measuring
Tools

TM 9-247 Materials Used for Cleaning, Preserving,
Abrading, and Cementing

TM 9-2610-200-20 Care, Maintenance, and Repair. of Pneumatic
Tires, Inner Tubes, and Radial Tires

TM 9-2610-201-14 Inspection and Classification of Tires

TM 9-2920-225-34 Generator Assembly

TM 9-4910-571-12&P Simplified Test Equipment for Internal
Combustion Engines

TM 9-6140-200-14 Operation and Organizational Maintenance
Manual for Lead Acid Storage Batteries

TM 9-8000 Principles of Automotive Vehicles

TM 38-230-1 and
TM 38-230-2 Preservation, Packaging, and Packing of
Military Supplies and Equipment

TM 740-90-1 Administrative Storage of Equipment

TM 746-10 General Packing Instructions

TM 750-244-6 Procedures for Destruction of Tank
Automotive Equipment to Prevent Enemy Use

TM 750-254 Cooling Systems: Tactical Vehicles

A-6. TECHNICAL BULLETINS

TB 9-2300-247-40	Tactical Wheeled Vehicles, Repair of Frames
TB 9-2300-405-14	Mandatory Brake Hose Inspection and Replacement
TB 9-2300-422-20	Security of Tactical Wheeled Vehicles
TB 43-0001-39	Equipment Improvement Report and Maintenance Digest
TB 43-0142	Safety Inspection and Testing of Lifting Devices
TB 43-0209	Color Marking, and Camouflage Painting of Military Vehicles, Construction Equipment, and Materials Handling Equipment
TB 43-0210	Nonaeronautical Equipment Army Oil Analysis Program (AOAP)
TB 750-93-1	Functional Grouping Codes
TB 750-651	Use of Antifreeze Solutions, and Cleaning Compounds in Engine Cooling Systems

A-7 . SUPPLY CATALOGS

SC 4910-95-CL-A72	Shop Equipment, Automotive Maintenance and Repair, Organizational: Common No. 2 (NSN 4910-00-754-0650)
Sc 4910-95-CL-A73	Shop Equipment, Automotive Maintenance and Repair, Organizational: supplemental No. 1, (NSN 4910-00-754-0653)
SC 4910-95-CL-A74	Shop Equipment, Automotive Maintenance and Repair, Organizational: Common No. 1 (NSN 4910-00-754-0654)

A-8 . OTHER PUBLICATIONS

CTA 50-970	Expendable/Durable Items (Except Medical Class V, Repair Parts, and Heraldic (Items)
DA PAM 738-750	The Army Maintenance Management System (TAMMS)
MIL-STD-129	Marking for Shipment and Storage
MIL-P-116	Methods of Preservation
MIL-B-12841	Preparation for Shipment and Storage of Basic Issue Item
MIL-V-62038	Shipment and Limited Storage
MM-L-751	Softwood Lumber

A-9. ARMY REGULATIONS

AR 310-2	Identification and Distribution of DA Publications and Issue of Agency Command Administration Publications
AR 310-25	Dictionary of United States Army Terms

A-9 . ARMY REGULATIONS (CONT)

AR 385-40	Accident Reporting and Records
AR 385-55	Prevention of Motor Vehicle Accidents
AR 700-15	Packaging of Material

APPENDIX B

MAINTENANCE ALLOCATION CHART
FOR
LOADER, SCOOP 2½ CU YD (CCE)
CATERPILLAR MODEL 950BNS/950BS

Section I. INTRODUCTION

1. General: This Maintenance Allocation Chart designates responsibility for performance of Maintenance functions to specific Maintenance categories.
2. Maintenance functions:
 - a. Inspect: To determine the serviceability of an item by comparing its physical, mechanical and/or electrical characteristics with established standards through examination.
 - b. Test: To verify serviceability and detect incipient failures by measuring the mechanical or electrical characteristics of an item and comparing those characteristics with prescribed standards.
 - c. Service: Operations required periodically to keep an item in proper operating condition, i.e., to clean (decontaminate), to preserve, to drain, to paint, or to replenish fuel, lubricants, hydraulic fluids, or compressed air supplies.
 - d. Adjust: To maintain, within prescribed limits, by bringing into proper or exact position or by setting the operation characteristics to specified parameters.
 - e. Align: To adjust specified variable elements of an item to bring optimum or desired performance.
 - f. Calibrate: To determine and cause corrections to be made or to be adjusted 'merits or test measuring and diagnostic equipment used in precision measurement. Consists of comparisons of two instruments, one of which is a certified standard of known accuracy, to detect and adjust any discrepancy in the accuracy of the instrument being compared.
 - g. Install: The act of emplacing, seating, or fixing into position an item, part, or module (component or assembly) in a manner to allow the proper functioning of an equipment or system.
 - h. Replace: The act of substituting a serviceable like type part, subassembly, or module (component or assembly) for an unserviceable counterpart.
 - i. Repair: The application of maintenance services or other maintenance actions to restore serviceability to an item by correcting specific damage, fault, malfunction, or failure in part, subassembly, module (component or assembly), end item, or system.

j. Overhaul: That maintenance effort (service/action) necessary to restore an item to a completely serviceable/operational condition as prescribed by maintenance standards (i.e., DMWR) in appropriate technical publications. Overhaul is normally the highest degree of maintenance performed by the Army. Overhaul does not normally return an item to like new condition.

k. Rebuild: Consists of those services/actions necessary for the restoration of unserviceable equipment to a like new condition in accordance with original manufacturing standards. Rebuild is the highest degree of materiel maintenance applied to Army equipment. The rebuild operation includes the act of returning to zero those age measurements (hours/miles, etc.) considered in classifying Army equipments/components.

3. Column entries: Columns used in the Maintenance Allocation Chart are explained below:

a. Column 1, Group Number: Column 1 lists group numbers, the purpose of which is to identify components, assemblies, subassemblies, and modules with the next higher assembly.

b. Column 2, Component/Assembly: Column 2 contains the noun names of components, assemblies, subassemblies, and modules for which maintenance is authorized.

Column 3, Maintenance Functions: Column 3 lists the functions to be performed on the item listed in Column 2.

d. Column 4, Maintenance Category: Column 4 specifies, by the listing of a "work time" figure in the appropriate subcolumn(s), the lowest level of maintenance authorized to perform the function listed in Column 3. This figure represents the active time required to perform that maintenance function at the indicated category of maintenance. If the number or complexity of the tasks within the listed maintenance function vary at different maintenance categories, appropriate "work time" figures will be shown for each category. The number of manhours specified by the "work time" figure represents the average time required to restore an item to a serviceable condition. This time includes preparation time, troubleshooting time, and quality assurance/quality control time in addition to the time required to perform the specific tasks identified in the Maintenance Allocation Chart.

e. Column 5, Tools and Equipment: Column 5 specifies by code those common tool sets (not individual tools) and special tools, test and support equipment required to perform the designated function.

f. Column 6, Remarks: Column 6 contains an alphabetic code which leads to the remark in Section IV, Remarks, which is pertinent to the item opposite the particular code.

Section II. MAINTENANCE ALLOCATION CHART

GROUP NUMBER (1)	COMPONENT/ASSEMBLY (2)	MAINTENANCE FUNCTION (3)	(4) MAINTENANCE LEVEL					TOOLS & EQUIP (5)	REMARKS (6)
			UNIT		DS	GS	DEPOT		
			C	O	F	H	D		
01	ENGINE								
0100	Engine Assembly	Inspect Service Replace Repair Overhaul	0.2 0.5	1.0	14.0	5.0	40.0	1 2 6,8-12 6,8-12	A C D
0101	Crankcase, Block, Cylinder Head:								
	Crankcase Block	Replace Repair Overhaul				60.0 5.0	26.0	2 6 6	
	Cylinder Head Assembly	Replace Repair			5.0	6.0		2 6	
0102	Crankshaft:								
	Crankshaft Assembly	Replace Overhaul				8.0	5.0	2 6	E
0103	Flywheel:								
	Flywheel Assembly	Replace Repair			4.3	3.0		2 6	
0104	Pistons and Connecting Rods	Replace Repair				7.0 3.0		2 2	
0105	Valves, Camshaft and Timing System:								
	Rocker Arm Assembly	Adjust Replace Repair			1.0 2.0 3.0			1 2 2	F
0106	Engine Lubrication System:								
	Filter Base Assembly, Oil	Service Replace Repair		0.4 1.0 2.0				1 1 1	
	Pump Assembly, Oil	Replace Repair			2.6	2.0		1 2	G
03	FUEL SYSTEM								
0301	Fuel Injection Nozzles	Test Replace Repair			1.0 1.0	1.5		7 9,15 2,7	J
0302	Fuel Pumps:								
	Pump, Transfer	Replace Repair		0.5	1.0			2 2	
	Pump, Fuel Injection	Adjust Replace Repair Overhaul			1.0 2.5		7.5	2,14 3,12 2,12,13,14 2,6,12,13 14	L L-1

Section II. MAINTENANCE ALLOCATION CHART

GROUP NUMBER (1)	COMPONENT/ASSEMBLY (2)	MAINTENANCE FUNCTION (3)	(4) MAINTENANCE LEVEL					TOOLS & EQUIP (5)	REMARKS (6)
			UNIT		DS	GS	DEPOT		
			C	O	F	H	D		
0304	Air Cleaner:	Inspect	0.1					1	
		Service		0.2				1	
		Replace		0.5				1	
	Elements	Service		0.2				1	
		Replace		0.2				1	
	Precleaner	Service	0.2					1	I
		Replace		0.2				1	
0305	Turbocharger	Replace		1.5				2	
		Repair				2.0		2	
0306	Tanks, Lines, Fittings, Headers:								B
	Tank, Fuel	Inspect	0.2						
		Service		0.3					
		Replace		2.0				3	
		Repair			2.0			3.5	
0308	Governor and Controls:								
	Governor Assembly	Replace				3.0			
		Repair				3.0			
	Governor Controls and Linkage	Service		0.3				2	
		Adjust				1.0		3,14	
		Replace				1.5		2,3,14	
0309	Fuel Filters:								
	Fuel Filter, Primary	Inspect		0.1					
		Service		0.5				1	
		Replace		0.3				1	
0311	Starting Aids	Service		0.2				1	
		Replace		1.0				1	
04	EXHAUST SYSTEM								
0401	Muffler and Pipes	Replace		2.0				1	
05	COOLING SYSTEM								M
0501	Radiator	Inspect	0.1						
		Test		1.0				3	
		Service	0.2	0.5				3	
		Replace			3.0			3.5	
		Repair			3.0				
0503	Manifold, Thermostat, and Housing Gasket:								
	Regulator	Test		1.0				3	
		Replace		1.0				1	
0504	Water Pump	Replace		2.5				2	
		Repair			1.0			2,3	
		Service		0.4					

Section II. MAINTENANCE ALLOCATION CHART

GROUP NUMBER (1)	COMPONENT/ASSEMBLY (2)	MAINTENANCE FUNCTION (3)	(4) MAINTENANCE LEVEL					TOOLS & EQUIP (5)	REMARKS (6)
			UNIT		DS	GS			
			C	O	F	H	D		
0505	Fan Assembly:								
	Fan Drive	Replace Repair		1.5	0.5			2,3	
	V-Belts	Inspect Adjust Replace	0.1	0.2 0.5				1 1	
06	ELECTRICAL SYSTEM								
0601	Alternator	Test Replace Repair		0.5 1.0	1.5			3 3 2,6	
0603	Starting Motor	Test Replace Repair		0.5 1.0	3.0			3 3 2,6	
0607	Instruments and Control Panel:								
	Instrument Panel/ Monitoring System	Inspect Replace Repair	0.1	1.0	1.0			2 2,3	
0608	Miscellaneous Items:								
	Auxiliary Steering Electrical System	Replace Repair		1.0 0.5				2,3 2,3	
0609	Lights:								
	Flood Lights	Inspect Replace Repair	0.1	0.2 0.5				1 1	
	Running Lights	Inspect Replace Repair	0.1	0.2 0.5				1 1	
	Stoplights	Inspect Replace Repair	0.1	0.2 0.5				1 1	
	Blackout/Secure Lighting	Inspect Replace Repair	0.1	0.2 0.5				1 1	
0610	Sending Units	Test Replace		0.3 0.5				2 2	
0612	Batteries, Storage:								
	Batteries	Inspect Service Replace Repair	0.5 2.0	0.5 0.5	1.0			1 1 1,6	K

Section II. MAINTENANCE ALLOCATION CHART

GROUP NUMBER (1)	COMPONENT/ASSEMBLY (2)	MAINTENANCE FUNCTION (3)	(4) MAINTENANCE LEVEL					TOOLS & EQUIP (5)	REMARKS (6)	
			UNIT		DS	GS	DEPOT			
			C	O	F	H	D			
0613	Hull or Chassis Wiring:									
	Front Wiring Harness	Test Replace Repair		1.0		4.0			3 2 2.6	
	Rear Wiring Harness	Test Replace Repair		1.0		2.0			3 2 2.6	
	Cab Wiring Harness	Test Replace Repair		1.0		1.0			3 2 2.6	
07	TRANSMISSION									
0708	Torque Converter Assembly (Integral With Transmission)	Replace Repair			8.0		9.0		2 2.4	
0710	Transmission & Mounting Assembly:									
	Transmission	Inspect Service Replace Repair Overhaul	0.2 0.2	0.5	10.0		8.0	25.0	1 2 2 2.4,6	H B
0714	Control Valves and Linkage:									
	Control Valves	Replace Repair			1.0		3.0		2 2.4	
	Control Linkage	Adjust Replace		1.0 1.0					1 2	
0714	Neutralizing Group	Replace Repair			1.0		2.0		2 2	
0719	Transfer Gears:									
	Transfer Gear Group	Replace Repair			2.0		3.0		2 2	
0721	Charging Pump and Filter Assembly:									
	Charging Pump	Replace Repair			2.0		3.0		2 2.6	
	Filter Assembly, Oil	Service Repair		0.2 0.4					1 1	
09	PROPELLER SHAFTS									
0900	Propeller Shafts Front:	Service Replace Repair		0.3 2.5		1.0			1 2 2	
	Propeller Shaft, Center/Rear	Service Replace Repair		0.3 1.0		1.0			1 2 2	

Section II. MAINTENANCE ALLOCATION CHART

GROUP NUMBER (1)	COMPONENT/ASSEMBLY (2)	MAINTENANCE FUNCTION (3)	(4) MAINTENANCE LEVEL					TOOLS & EQUIP (5)	REMARKS (6)
			UNIT		DS	GS	DEPOT		
			C	O	F	H	D		
10	FRONT AXLE								
1000	Front Axle Assembly (Rigid)	Service Replace Repair			5.0 5.0			2 2	
1002	Front Axle Differential Assembly	Service Replace Repair		0.3	2.0		2.0	1 2,3 2,3	
1003	Front Axle Final Drive Assemblies	Service Replace Repair		0.3	3.0		2.0	1 2,3 2,3	
11	REAR AXLE								
1100	Rear Axle Assembly (Oscillating)	Replace Repair			5.0 5.0			2,3 2,3	
1102	Rear Axle Differential Assembly	Service Replace Repair		0.3	3.0		2.0	1 2,3 2,3	
1103	Rear Axle Final Drive Assemblies	Service Replace Repair		0.3	3.0		2.0	1 2,3 2,3	
12	BRAKES								
1201	Parking Brake:	Inspect Replace Repair Test	0.1	1.0	1.0 1.0			2 2	
	Parking Brake Chamber	Replace Repair		1.0	1.5			2 2	
	Parking Brake Linkage	Inspect Replace		0.2 1.0				2	
1204	Hydraulic Brake System:								
	Hydraulic Reservoir	Service Replace Repair		0.2 0.8	1.0			1 3 3.5	
	Air/Hydraulic Cylinder	Replace Repair			0.5 1.0			2 2	
	Calipers	Replace Repair			1.2 1.5			2 2,6	
1208	Air Brake System:								
	Brake Actuator	Replace Repair		1.0	1.5			2 2	
	Brake Treadle Valve	Inspect Replace Repair	0.1	1.0	1.5			2 2	

Section II. MAINTENANCE ALLOCATION CHART

GROUP NUMBER (1)	COMPONENT/ASSEMBLY (2)	MAINTENANCE FUNCTION (3)	(4) MAINTENANCE LEVEL					TOOLS & EQUIP (5)	REMARKS (6)
			UNIT		DS	GS	DEPOT		
			C	O	F	H	D		
1208 (cont)	Air Brake Reservoir	Inspect Service Replace	0.2 0.1	0.8				1 2	
	Pressure Protection Valve	Replace Repair		0.8	0.5			1 1	
	Double Check Valve and Stop Light Switch	Replace Repair		0.8	0.5			1 1	
1209	Air Compressor Assembly:	Replace Repair		1.0	1.0			2 2	
	Governor	Adjust Replace Repair		0.8 0.8	1.0			1 2 2	
13	WHEELS								
1311	Wheel Assembly	Replace Repair		1.0	1.5			2 2.5	
1313	Tires	Inspect	0.1						
		Service	0.2	0.3				2.4	
		Replace Repair		2.0 1.0				2.4 2.4	
14	STEERING								
1407	Power Steering Gear (& Steering Column)	Replace			2.0			2	
		Repair				3.0		2	
		Adjust		1.5				1	
1410	Aux/Emergency Steering Motor and Pump	Replace			0.8			2	
		Repair			2.0			2	
		Test			1.0			3	
1411	Steering Hoses, Lines & Fittings (Articulation):	Inspect	0.2						
		Replace		2.5				2	
1412	Steering Cylinder Assemblies	Service		0.3				3	
		Replace		0.3				3	
1414	Flow Control Valve	Replace			1.0			2	
		Repair			2.0			2	
		Adjst			0.8 3.0 0.8			2 2 1	
15	FRAME TOWING ATTACHMENTS, DRAWBARS AND ARTICULATION SYSTEM								
1501	Rear Chassis Assembly (Engine End)	Repair				0.3		2.5	

Section II. MAINTENANCE ALLOCATION CHART

GROUP NUMBER (1)	COMPONENT/ASSEMBLY (2)	MAINTENANCE FUNCTION (3)	(4) MAINTENANCE LEV					TOOLS & EQUIP (5)	REMARKS (6)
			UNIT		DS	GS	DEPOT		
			C	O	F	H	D		
1501 (Cont)	Front Chassis Assembly (Non-Engine End)	Repair				0.3		2,5	
18	BODY, CAB, HOOD & HULL								
1806	Seat Assembly	Replace Repair		1.0	1.5			2 2	
22	BODY, CHASSIS, & HULL ACCESSORY ITEMS								
2202	Accessory Items: Air Horn Assembly	Replace Repair		0.5 1.0				2 2	
24	HYDRAULIC AND FLUID SYSTEMS								
2401	Pilot and Hydraulic Pump:	Replace Repair Overhaul			2.5	1.5	3.0	2 2 2.6	
	Motor/Pump Assembly, Coupler	Replace Repair			1.0	2.0		2 2	
2402	Control Valve Assembly	Adjust Replace Repair			1.0 2.0	1.5		2 2 2	
2403	Hydraulic Control Levers and Linkages	Adjust Replace Repair			0.5 1.0 1.0			1 2 2	
2404	Hydraulic Tilt Cylinder Assembly:	Inspect Replace Repair	0.1	1.0	2.0			2 2	
	Positioner & Kickout Assembly	Adjust Replace Repair		0.5	0.5 0.5			1 2 2	
2406	Hydraulic Lines and Fittings	Replace Repair		1.0	0.5			2,4,5 16-19	
2407	Hydraulic Lift Cylinder Assemblies (Left & Right):	Inspect Replace Repair	0.2	2.0	2.5			2 2	
	Bucket Cylinders	Replace Repair		1.5	3.0			2,4,5 7	
2408	Hydraulic Reservoir:	Inspect Service Replace Repair	0.1 0.2	0.2	2.0 2.0			1 2 3,5	
	Hydraulic System Filter	Service Replace		0.3 0.3				1 3	

Section II. MAINTENANCE ALLOCATION CHART

GROUP NUMBER (1)	COMPONENT/ASSEMBLY (2)	MAINTENANCE FUNCTION (3)	(4) MAINTENANCE LEVEL					TOOLS & EQUIP (5)	REMARKS (6)
			UNIT		DS	GS	DEPOT		
			C	O	F	H	D		
3307	Trailer, Air Transport	Service Replace Repair		0.2 0.3	2.0			1 2 2,3	
74	CRANES, SHOVELS AND EARTH MOVING EQUIPMENT COMPONENTS								
7436	Bucket Lift Arms & Pivot Assemblies	Replace Repair			3.0 6.0			2 2	
7437	Loader Bucket Assembly	Inspect Replace Repair	0.1	1.5	4.0			2 2	
	Bucket Cutting Edge Assembly	Inspect Replace	0.1	1.0				2	
	Bucket Shank Assemblies	Inspect Replace	0.1	1.0				2	

Section III. TOOL AND TEST EQUIPMENT REQUIREMENTS

TOOL OR TEST EQUIPMENT REFERENCE CODE	MAINTENANCE CATEGORY	NOMENCLATURE	NATIONAL/NATO STOCK NUMBER	TOOL NUMBER	FSCM
1.	O	Tool Kit, Auto Mechanics SC5180-90-CL-N26	5180-00-177-7033	#W33004	50980
2.	O,F	Tool Kit, Master Mechanics SC5180-90-CL-N05	5180-00-699-5273	#W45060	50980
3.	O	Shop Equipment, Automotive Maintenance and Repair, Common #1 Less Power SC4910-95-CL-A74	4910-00-754-0654	#W32593	19204
4.	O	Shop Equipment, Automotive Maintenance, Common #2 Less Power SC4910-95-CL-A72	4910-00-754-0650	#W32730	19204
5.	F	Shop Sets, Welding SC3470-95-CL-A08	4940-00-357-7268	#T16714	19204
6.	F,H	Shop Equipment, General Purpose Repair, Semi-Trailer Mounted SC4940-95-CL-B02	4940-00-287-4894	#T10549	19204
7.	F,H	Test Set, Diesel Injector SC4910-1L	4910-00-317-8256	#V73742	19207
8.	H	Ring, Distorter, Front	5120-01-119-1750	5P7315	11083
9.	H	Ring, Distorter, Rear	5120-01-119-1749	5P7313	11083
10.	O	Bolt, Eye	5306-01-172-2527	1P7409	11083
11.	H	Distorter, Wear Sleeve	5120-01-119-1748	5P7312	11083
12.	F	Wrench, Injector Pump Removal	5120-01-124-1773	8T5287	11083
13.	F	Extractor, Injector	5120-00-178-1267	8S2244	11083
14.	F	Pin, Timing	2815-01-268-2194	6V4186	11083
15.	F	Nozzle Puller	2910-01-250-1608	6V6980	11083
16.	F	Hose Press Arrangement	4940-01-272-2839	5P4180	11083
17.	F	Hand Pump, Hydraulic (A Pump Repair Kit is available but not provided with the Pump)		1U5230 1U5229	11083 11083
18.	F	Hose Assembly (Attaches Pump to Hose Press)		8F24	11083
19.	F	Coupler Assembly (Attaches Pump to Hose Press)		1P2376	11083

Section IV. REMARKS

REFERENCE CODE	REMARKS
A	Inspect by checking lubricating oil level, and checking for leaks.
B	Service by cleaning screen.
C	Service by changing engine oil.
D	Complete engine gasket kit is available.
E	Undersize bearings are available.
F	Valve mechanism adjustment consists of measuring clearance between rocker arm and valve turning adjustment screw. This procedure also indicates how to locate top dead center for no. 1 piston.
G	Includes the removal of the suction bell.
H	Inspect by checking transmission fluid level, and checking for leaks.
I	Service by cleaning.
J	Test nozzle prior to disassembly to determine if nozzle can be reused.
K	Battery maintenance instructions are provided in TM9-6140-200-14.
L	Fuel injection pump timing checks can be performed on or off engine.
M	Inspect by checking coolant level and by checking for leaks.
N	Setting high and low idle.
L-1	Overhaul at special level (L).

CCE MANUFACTURER FIELD CAMPAIGNS AND MODIFICATION PROCEDURES

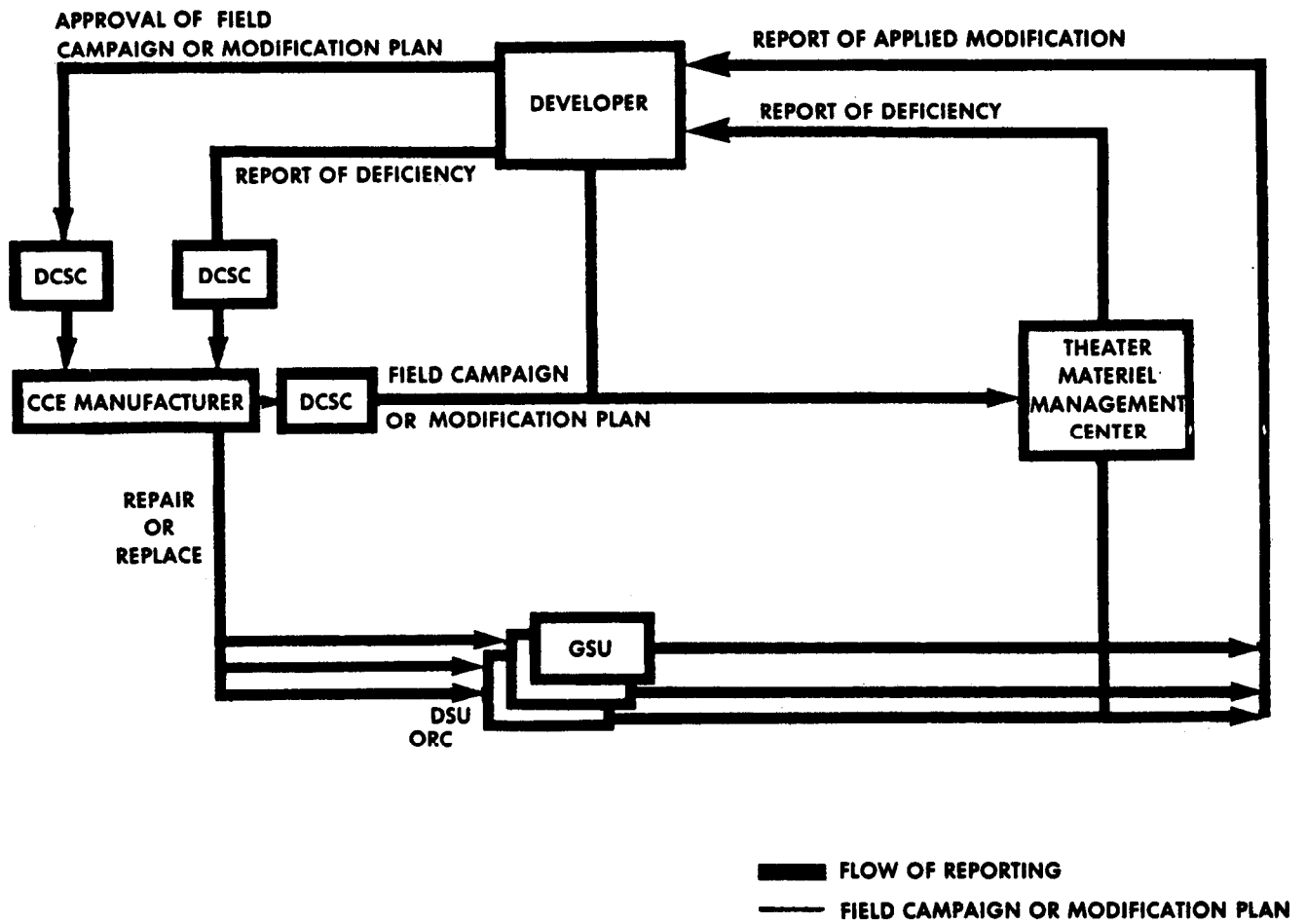

BASIC ISSUE ITEMS LIST

(1) NATIONAL STOCK NUMBER	(2) DESCRIPTION USABLE ON CODE	(3) UNIT OF MEAS	(4) QTY FURN WITH EQUIP	(5) ILLUSTRATION	
				(A) FIG NO	(B) ITEM NO.
7520-00-559-9618	Case Maintenance and Operational Manual	Each	1		
7510-00-889-3494	Binder, Log Book	Each	1		
	Combination Box & Open End Wrenches				
5120-00-228-9503	5/16"	Each	1		
5120-00-228-9504	3/8"	Each	1		
5120-00-228-9505	7/16"	Each	1		
5120-00-228-9506	1/2"	Each	1		
5120-00-228-9507	9/16"	Each	1		
5120-00-228-9508	5/8"	Each	1		
	Wrench Sockets with 1/2 inch Drive				
5120-00-189-7985	3/4"	Each	1		
5120-00-189-7935	15/16"	Each	1		
5120-00-189-7927	1"	Each	1		
5120-00-189-7914	1-1/8	Each	1		
5120-00-277-1465	1-1/2"	Each	1		
5120-00-889-1695	Wrench, Ratchet 1/2" Drive	Each	1		
5120-00-235-5872	Wrench, Universal 3/8 Drive with 3/8" 12 Point Socket	Each	1		
5130-00-227-8107	Extension, Socket, 3/8 Drive, 5" Long (6")	Each	1		
5130-01-056-7716	Adapter, Socket, 1/2" Female to 3/8" Male	Each	1		
5120-00-234-8910	Screwdriver, Standard, 6" with 5/16 Blade	Each	1		
5120-00-242-3915	Hammer, 3lb.	Each	1		
5120-00-223-7398	Pliers, Slip Joint, 10"	Each	1		
5230-00-264-8261	Flashlight	Each	1		
5120-01-135-2004	Prybar, 24" long	Each	1		
5120-00-203-4792	Wrench, Open End Striking, 2-1/2" Punch, 1/2"	Each	1		
	Tube, Wall, 24" long	Each	2		
	Tiedowns, 3 Ft.	Each	3		
	Chain, Length of, 20 ft. w/Binder 1/4 or 3/8	Each	1		
5306-00-426-3150	Bolt, Hex Hd, 5/8-11 X2-3/4 in. lg. 1A8537	Each	2		
5306-00-272-4246	Bolt, Hex Hd, 5/8-11 X 3-1/2 in. lg. 1D4586	Each	2		
2590-01-168-1691	Jack Assembly 5R5583	Each	2		
5315-01-176-2512	Rod 5R5283	Each	2		
5340-01-165-2640	Rod 5R5270	Each	2		

BASIC ISSUE ITEMS LIST

(1) NATIONAL STOCK NUMBER	(2) REF NO.& MFR CODE	DESCRIPTION	USABLE ON CODE	(3) UNIT OF MEAS	(4) QTY FURN WITH EQUIP	(5) ILLUSTRATION	
						(A) FIG NO	(B) ITEM NO.
2540-01-166-4445		Tool Box 5R5598		Each	1		
2510-01-177-8557		Puller, Upper Pin 5R5243					
5365-01-176-2040		Sliding Weight 5R5246					
3805-01-167-9173		Skid Group 5R5586		Each	1		
2510-01-165-6010		Bracket Assembly 5R5504		Each	1		
		Pad Assembly 5R7439		Each	2		

SAMPLE FORM DA FORM 2765 PART NUMBER REQUEST

(CONUS REQUESTOR)

BALTIMORE BUSINESS FORMS, INC. DANCS1-82-C-0011
USE TYPEWRITER OR BALL POINT PEN
PRESS HARD TO ASSURE LEGIBILITY ON ALL COPIES
SEND TO: _____

WEAPONS SYS DSG CODE → 37 B G W

USE THE FSCM AS THE FIRST 5 DIGITS OF THE PART NUMBER. → 334 I 346020

SAMPLE

DSS PROJECT CODE → 37 B G W

REQUEST FOR ISSUE OR TURN-IN (DA Form 710-2-1)

DOC IDENT	ROOT IDENT	FSC	WTR	STOCK NUMBER	ADD	QUANTITY	REQUISITION DATE	DATE	SERIAL	SUPPLEMENTARY ADDRESS	FUND	DISTR	PROJECT	PR	REG DEL DATE	ADV	STAT
EDITING DATA																	
DOC IDENT	RI	YO	SUF	DOC IDENT	IDENTIFIER	FSC	MIN	ADD	UNIT OF ISSUE	QUANTITY							
FUND DISTRIBUTION PROJECT PRIORITY REG DEL DATE FUNDED NON-FUNDED																	
ADVISE 23																	
M-C CODE ISSUED DATE POSTED INIT																	
O DUE OUT DATE AVAILABLE INIT																	
U RECEIVED DATE RECEIVED SIGNATURE																	
1 2 3 4 5 6 7 8 9 10 11 12 13 14 15 16 17 18 19 20 21 22 23 24 25 26 27 28 29 30 31 32 33 34 35 36 37 38 39 40 41 42 43 44 45 46 47 48 49 50 51 52 53 54 55 56 57 58 59 60 61 62 63 64 65 66 67 68 69 70 71 72 73 74 75 76 77 78 79 80																	

(OCONUS REQUESTOR)

BALTIMORE BUSINESS FORMS, INC. DANCS1-82-C-0011
USE TYPEWRITER OR BALL POINT PEN
PRESS HARD TO ASSURE LEGIBILITY ON ALL COPIES
SEND TO: _____

WEAPONS SYS DSG CODE → 37 J Z C

USE THE FSCM AS THE FIRST 5 DIGITS OF THE PART NUMBER. → 334 I 346020

SAMPLE

SPECIAL PROJECT CODE → 37 J Z C

REQUEST FOR ISSUE OR TURN-IN (DA Form 710-2-1)

DOC IDENT	ROOT IDENT	FSC	WTR	STOCK NUMBER	ADD	QUANTITY	REQUISITION DATE	DATE	SERIAL	SUPPLEMENTARY ADDRESS	FUND	DISTR	PROJECT	PR	REG DEL DATE	ADV	STAT
EDITING DATA																	
DOC IDENT	RI	YO	SUF	DOC IDENT	IDENTIFIER	FSC	MIN	ADD	UNIT OF ISSUE	QUANTITY							
FUND DISTRIBUTION PROJECT PRIORITY REG DEL DATE FUNDED NON-FUNDED																	
ADVISE 23																	
M-C CODE ISSUED DATE POSTED INIT																	
O DUE OUT DATE AVAILABLE INIT																	
U RECEIVED DATE RECEIVED SIGNATURE																	
1 2 3 4 5 6 7 8 9 10 11 12 13 14 15 16 17 18 19 20 21 22 23 24 25 26 27 28 29 30 31 32 33 34 35 36 37 38 39 40 41 42 43 44 45 46 47 48 49 50 51 52 53 54 55 56 57 58 59 60 61 62 63 64 65 66 67 68 69 70 71 72 73 74 75 76 77 78 79 80																	

SAMPLE FORM MILSTRIP REQUISITION FOR (NSN)

DOCUMENT IDENTIFIER CODE → AOA

DISTRIBUTION CODE → FXXB

DDS CODE → 256

NSN → 5325010700942

Quantity → 100

Unit of Issue → [Blank]

Document Number → XXXXXXXXXXXXXXXX

Supplementary Address → XXXXXXXX

Fund Code → FXXB

Project Code → XXXX

Priority Code → XX

Required Delivery Date → 256

Advice Code → [Blank]

CARD COLUMN	DESCRIPTION OF DATA	MANDATORY ENTRY FOR CCE
1-3	Document Identifier Code	AOA - CONUS A01 - Overseas
4-6	Routing Identifier Code	
7	Media/Status Code	
8-22	NSN	
23-24	Unit of Issue	
25-29	Quantity	
30-43	Document Number	
44	Demand Code	
45-50	Supplementary Address	
51	Signal Code	
52-53	Fund Code	
54-56	Distribution Code CC-54	"F" for CONUS; see AR 725-50 for OCONUS
	CC-55-56	Weapon System Code (DSS) Code
57-59	Project Code	
60-61	Priority Code	
62-64	Required Delivery Date	
65-66	Advice Code	

SAMPLE FORM MILSTRIP REQUISITION FOR (NON-NSN)

<u>CARD COLUMN</u>	<u>DESCRIPTION OF DATA</u>	<u>MANDATORY ENTRY FOR CCE</u>
1-3	Document Identifier Code	AOB - CONUS A02 - Overseas
4-6	Routing Identifier Code	Always S9C
7	Media/Status Code	
8-22	FSCM and Part Number	
23-24	Unit of Issue	
25-29	Quantity	
30-43	Document Number	
44	Demand Code	
45-50	Supplementary Address	
51	Signal Code	
52-53	Fund Code	
54-56	Distribution Code CC-54	"F" for CONUS; see AR 725-50 for OCONUS
	CC-55-56	Weapon System Code
57-59	Project Code	CCE (DSS) Code
60-61	Priority Code	
62-64	Required Delivery Date	
65-66	Advice Code	

APPENDIX G (CONT'D)

<u>CARD COLUMN</u>	<u>DESCRIPTION OF DATA</u>	<u>MANDATORY ENTRY FOR CCE</u>
67-69	Blank	
70	Identification code applicable to entry in cc 71-80. A - Technical order or Technical Manual. B - End Item Identification C- Noun Description D - Drawing or Specification No.	
71-80	Reference Identification	Identification of reference specified in cc 70

**DO YOU NEED A REPAIR PART
FOR
ONE OF YOUR COMMERCIAL CONSTRUCTION
OR
MATERIALS HANDLING EQUIPMENT ITEMS?
YES? THEN FOLLOW THESE 4 EASY STEPS!**

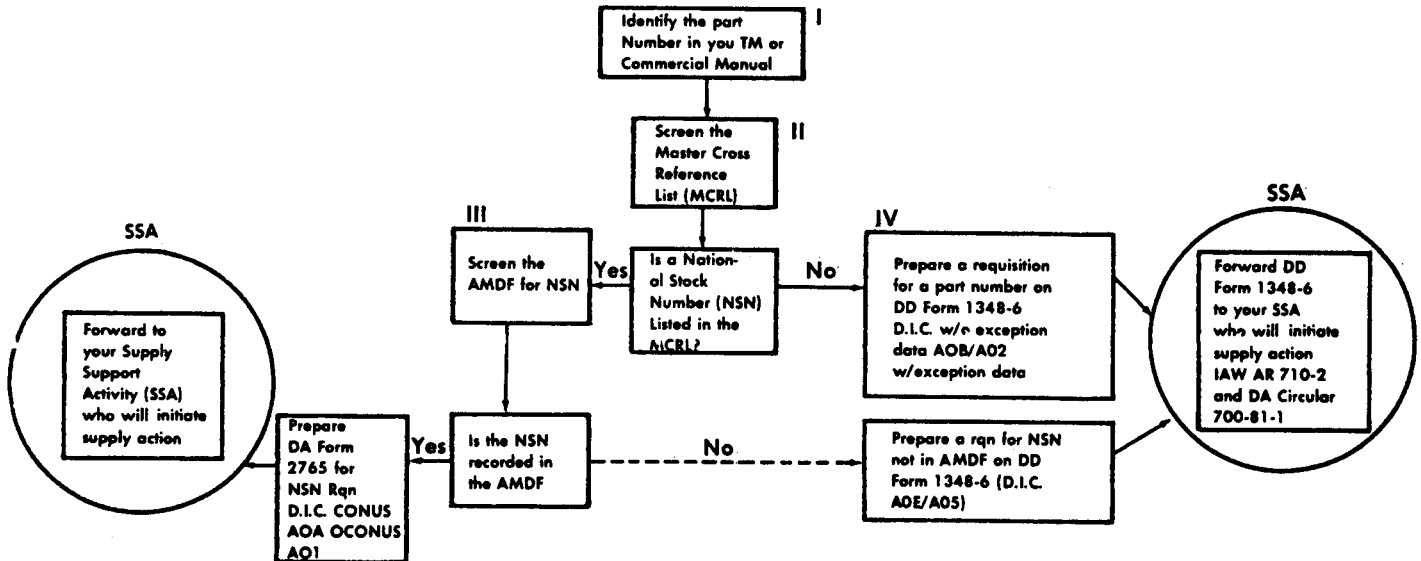

NON-NSN REQUISITION (MANUAL)

DD FORM 1348-6 (Rev. 7-77)		NON-NSN REQUISITION (MANUAL)	
Figure A-1 Sample Non-NSN Requisition (Manual) (DD Form 1348-6)			

LEGEND FOR 1348-6

CARD COLUMNS	CONUS	OCONUS
1-3 DOC Ident Code -		
PN w/o Exception Data	A/B	A/2
PN w/Exception Data	A/E	A/5
NSN Not in AMDF	A/E	A/5
4-7 (LV Blank - SSA will complete)		
8-22 For Non NSN: Fed Supply Code for Manufacturer (FSCM followed by Part Number (obtain from TM or Commercial Manual))		
8-22 For NSN not in AMDF - enter NSN		
57-59 Project Code:	MHE	CCE
CONUS	BGX	BGW
OCONUS	JZM	JZC
Reference Code for Col. 71-80:		
A - Technical Order or Tech Manual.		
B - End item Application.		
C - Noun Description of Item.		
D - Drawing or Specification Number.		
Identification of reference Data specified in Col. 70.		
NOTE: All other entries will be made IAW AR 710-2/725-50. Project Codes are mandatory entries.		
MANUAL BLOCKS:		
BLOCK 1. Mfg Code & PN - Enter applicable FSCM and PN when they exceed Col. 8-22. (Col. 8-22 will be left blank).		
BLOCKS 2-8. Enter applicable data (obtain from TM or Commercial Manual).		
BLOCKS 8a-8d. Obtain data from vehicle data plate.		
BLOCK 9. Self explanatory.		
BLOCK 10. Enter any applicable exception data such as "NER not in AMDF".		

APPENDIX H

INSTRUCTIONS

This form will only be used in those cases where the manufacturer's code and part number exceed the spaces allocated in card columns 8-22 of the requisition.

<u>CARD COLUMN</u>	<u>DESCRIPTION DATA</u>	<u>MANDATORY ENTRY FOR CCE</u>
1 - 3	Document Identifier Code	AOE - CONUS AO5 - OCONUS
4 - 6	Routing Identifier Code	Always S9C
7	Media Status Code	
8 - 2 2	FSCM and Part Number	Leave Blank Enter In Block 1 under Identification Data
23-24	Unit of Issue	
25-29	Quantity	
30-43	Document Number	
44	Demand Code	
45-50	Supplementary Address	
51	Signal Code	
52-53	Fund Code	
54-56	Distribution Code CC 54 CC 55-56	"F" for CONUS. (See AR 725-50 for OCONUS) Weapon System Code
57-59	Project Code	
60-61	Priority Code	
62-64	Required Delivery Date	
65-66	Advice Code	
67-80		Blank

IDENTIFICATION DATA - Lower half of DD Form 1348-6, complete Blocks 1 thru 9:

MAINTENANCE AND OPERATING SUPPLY LIST

APPENDIX I

(1) COMPONENT APPLICATION		(2) MFR PART NO. OR NAT'L STOCK NO.	(3) DESCRIPTION	(4) QTY REQ F/INITIAL OPN	(5) QTY REQ F/8 HRS OPN	(6) NOTES
Engine		9150-00-188-9859 MIL-L-2104C	Oil Lubricating OE/HDO-30	5.7 Gal		May be required through first 1,000 hrs of operation
Transmission System & Torque Converter		MIL-L2104C 9150-00-188-9859	SAE 30	8.8 Gal		
Hydraulic System		MIL-L-2104B 9150-00-191-2772	SAE 10W	39.8 Gal		
Differential and Final Drives		MIL-L-2105C 9150-00-577-5844	SAE 90	Front 8.6 Gal Rear 9.9 Gal's		
Cooling System		1 Gallon Can 6850-00-243-1992 55 Gallon Drum 6850-00-644-1409	Antifreeze: Ethylene Glycol for Spec O-A-548	8.8 Gal		
Fuel System		9140-00-286-5294 SPEC VV-F-800	Diesel Fuel #2 DF2 Regular, Bulk	57.7 Gal		

I-1/I-2
(blank)

ORGANIZATIONAL
PREVENTIVE MAINTENANCE CHECKS AND SERVICES (PMCS)

GENERAL

To make sure that your vehicle is ready for operation at all times, inspect it systematically so you can discover any defects and have them corrected before they result in serious damage or failure. The charts on the next few pages contain your organizational PMCS. The item numbers indicate the sequence of minimum inspection requirements. If you are operating the vehicle and notice something wrong which could damage the equipment if you continue operation, stop operation immediately.

Record all deficiencies and shortcomings, along with the corrective action taken, on DA Form 2404. The Item Number column is the source for the numbers used on the TM Number column on DA Form 2404.

ORGANIZATIONAL PREVENTIVE MAINTENANCE CHECKS AND SERVICES (PMCS)

a. The item numbers of the table indicate the sequence of the PMCS. Perform at the intervals shown below:

- (1) Do your (Q) Preventive Maintenance Quarterly (every three months).
- (2) Do your (S) Preventive Maintenance Semiannually (every six months).
- (3) Do your (A) Preventive Maintenance Annually (once every year).
- (4) Do your (B) Preventive Maintenance Biennially (once every two years).
- (5) Do your (H) Preventive Maintenance at the hour interval listed.
- (6) Do your (Mi) Preventive Maintenance at the mile interval listed.

b. If something does not work, troubleshoot it with the instructions in this manual or notify your supervisor.

c. Always do your preventive maintenance in the same order, so it becomes a habit. Once you have had some practice, you will spot anything wrong in a hurry.

WARNING

Dry cleaning solvent P-D-680 is toxic and flammable. Wear protective goggles and gloves and use only in well ventilated areas. Avoid contact with skin, eyes and clothes and do not breathe vapors. Do not use near open flame or excessive heat. If you become dizzy while using cleaning solvent, get fresh air immediately and get medical aid. If contact with eyes is made, wash your eyes with water and get medical aid immediately.

Compressed air used for cleaning purposes will not exceed 30 psi. Use only with effective chip guarding and personnel protection equipment (goggles/shields/gloves, etc....).

(1) Keep it clean: Dirt, grease, oil and debris only get in the way and may cover up a serious problem. Clean as you work and as needed. Use dry cleaning solvent (P-D-680) to clean metal surfaces. Use soap and water when you clean rubber or plastic material.

(2) Bolts, nuts and screws: Check that they are not loose, missing, bent or broken. You can not try them all with a tool but look for chipped paint, bare metal or rust around bolt heads. Tighten any that you find loose.

(3) Welds: Look for loose or chipped paint, rust or gaps where parts are welded together. If you find a bad weld, report it to direct support.

(4) Electric wires and connector: Look for cracked or broken insulation, bare wires and loose or broken connectors. Tighten loose connections and make sure the wires are in good condition.

(5) Hoses and fluid lines: Look for wear, damage and leaks. Make sure clamps and fittings are tight. Wet spots show leaks but a stain around a fitting or connector can also mean a leak. If a leak comes from a loose fitting or connector, tighten it. If something is broken or worn out, either correct it or report it to direct support (refer to MAC Chart).

It is necessary for you to know how fluid leaks affect the status of your equipment. The following are definitions of types/classes of leakage you need to know to be able to determine the status of your equipment. Learn and be familiar with them and REMEMBER-When in doubt, notify your supervisor.

CLASS I-----Seepage of fluid (as indicated by wetness or discoloration) not great enough to form drops.

CLASS II-----Leakage of fluid great enough to form drops, but not enough to cause drops to drip from the item being checked/inspected.

CLASS III-----Leakage of fluid great enough to form drops that fall from the item being checked/inspected.

NOTE

Perform Operator/Crew PMCS prior to or in conjunction with Organizational PMCS if:

There is a delay between the daily Operation and the Organizational PMCS.

- b. Regular operator is not assisting/participating.

UNIT PREVENTIVE MAINTENANCE CHECKS AND SERVICES

M-MONTHLY Q-QUARTERLY S-SEMIANNUALLY A-ANNUALLY B-BIENNIALLY H-HOURS MI-MILES

ITEM NO.	INTERVAL							ITEM TO BE INSPECTED PROCEDURE: CHECK FOR AND HAVE REPAIRED, FILLED, OR ADJUSTED AS NEEDED PERFORM ALL OPERATOR PMCS FIRST
	M	Q	S	A	B	H	MI	
1.						250		<u>ENGINE:</u> Engine Crankcase: Change oil and filter elements. Page 1-46 Maintenance Manual 24-1 Note: Refer to TB43-0210. Clean crankcase breather. Page 1-67 Maintenance Manual 24-1 Engine Valve Lash Measure and adjust if necessary. Page 1-83 Maintenance Manual 24-1
		x				500		
					x		2000	
2.		x				500		<u>FUEL SYSTEM:</u> Wash tank cap and filler screen. Page 1-56 Maintenance Manual 24-1 Clean Primary filter - change final filter - prime fuel system. Page 1-63 Maintenance Manual 24-1 Drain moisture and sediment from tank. Page 1-29 Maintenance Manual 24-1
		x				500		
		x				500		
3.								<u>AIR CLEANER:</u> <p style="text-align: center;">WARNING</p> If NBC exposure is suspected, all air filter media should be handled by personnel wearing protective equipment. Consult your unit NBC Officer or NBC NCO for appropriate handling or disposal instructions. Check air filter for serviceability - discard the element if rips or tears are found. (See pages 1-18 thru 1-22 Maintenance Manual 24-1 for proper cleaning and testing of filter). Change primary filter. Change secondary filter every third time primary filter is serviced or replaced. Page 1-19 Maintenance Manual 24-1
		x				500		
					x		2000	

J-3

TM 5-3805-258-24-2

UNIT PREVENTIVE MAINTENANCE CHECKS AND SERVICES

M-MONTHLY Q-QUARTERLY S-SEMIANNUALLY A-ANNUALLY B-BIENNIALLY H-HOURS MI-MILES

ITEM NO.	INTERVAL							ITEM TO BE INSPECTED PROCEDURE: CHECK FOR AND HAVE REPAIRED, FILLED, OR ADJUSTED AS NEEDED PERFORM ALL OPERATOR PMCS FIRST
	M	Q	S	A	B	H	MI	
4.				x		2000		<u>COOLING SYSTEM:</u> Change coolant. Page 1-24 Maintenance Manual 24-1
				x		2000		Inspect cap for damage and replace if required. Page 1-83 Maintenance Manual 24-1
5.						250		<u>WATER PUMP:</u> Lubricate Fan bearing. Page 1-54 Maintenance Manual 24-1
6.		x				500		<u>ELECTRICAL SYSTEM:</u> Check for proper charge range. Electronic Monitoring System (EMS) light off.
						250		Inspect belts. Adjust as required. Page 1-53 Maintenance Manual 24-1
7.		x				500		<u>TRANSMISSION:</u> Replace transmission filter and check for leaks. Page 1-61 Maintenance Manual 24-1 Note: Refer to TB43-0210.
			x			1000		Change transmission oil. Page 1-68 Maintenance Manual 24-1 Note: Refer to TB43-0210.
			x			1000		Service magnetic strainer. Page 1-68 Maintenance Manual 24-1
			x			1000		Install new transmission breather. Page 1-70 Maintenance Manual 24-1

J-4

TM 5-3805-258-24-2

UNIT PREVENTIVE MAINTENANCE CHECKS AND SERVICES

M-MONTHLY Q-QUARTERLY S-SEMIANNUALLY A-ANNUALLY B-BIENNIALLY H-HOURS MI-MILES

ITEM NO.	INTERVAL							ITEM TO BE INSPECTED PROCEDURE: CHECK FOR AND HAVE REPAIRED, FILLED, OR ADJUSTED AS NEEDED PERFORM ALL OPERATOR PMCS FIRST
	M	Q	S	A	B	H	MI	
8.						250		<u>PROPELLER SHAFTS:</u> Inspect drive shaft spline and lubricate. Page 1-52 Maintenance Manual 24-1
			x			1000		Service drive shaft "U" joints and support bearing. Page 1-72 Maintenance Manual 24-1
9.		x				500		<u>FRONT AND REAR DIFFERENTIALS AND FINAL DRIVE</u> Check fluid level in differentials and final drive. Page 1-17 Maintenance Manual 24-1
				x		2000		Change differential and final drive gear oil. Page 1-75 Maintenance Manual 24-1
10.		x				500		<u>HYDRAULIC SYSTEM:</u> Change hydraulic filters. Page 1-57 Maintenance Manual 24-1
				x		2000		Change hydraulic oil and clean fill screen. Page 1-75 Maintenance Manual 24-1
11.						250		<u>BRAKES:</u> Check brake fluid reservoirs and seals. Fill as needed. Page 1-48 Maintenance Manual 24-1

J-5/J-6 (Blank)

TM 5-3805-258-24-2

950 chain down rail procedure

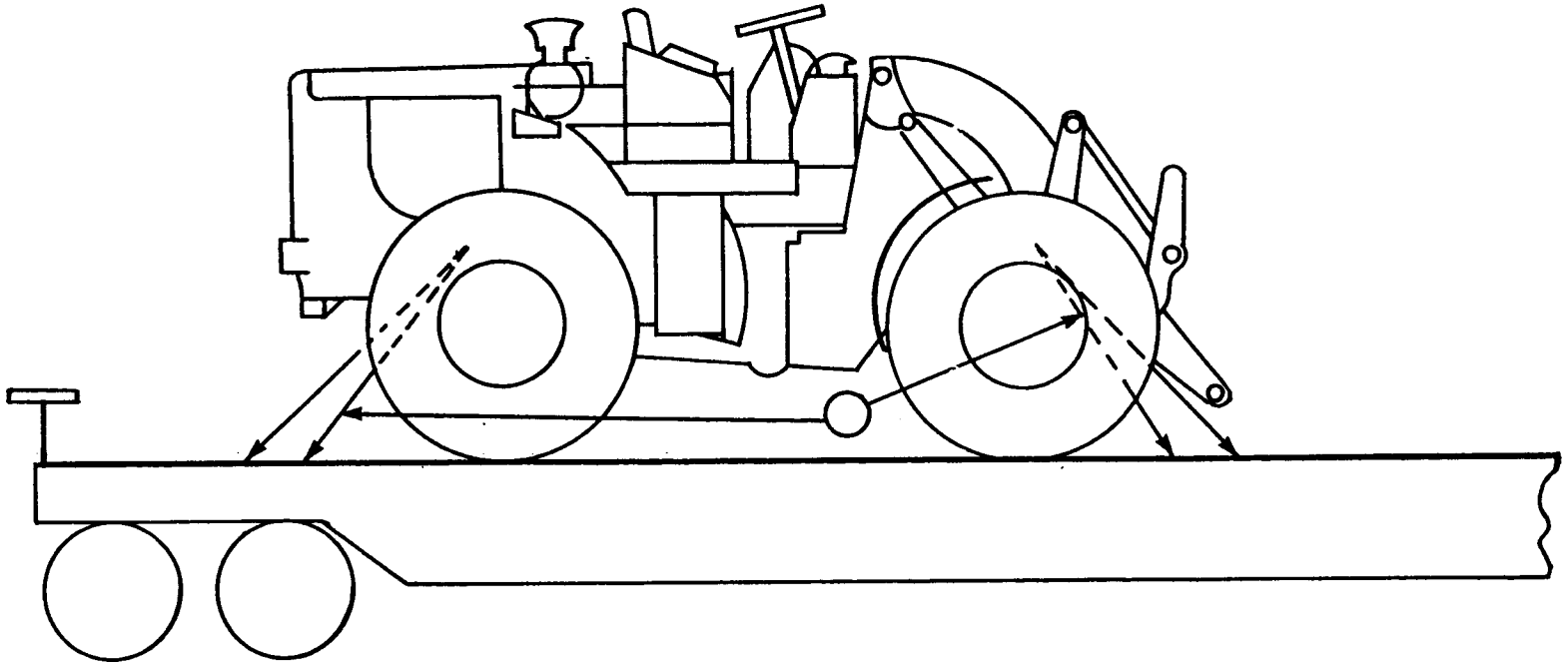

B. Longitudinal chains (8) required

Angle of chains not to exceed 45°

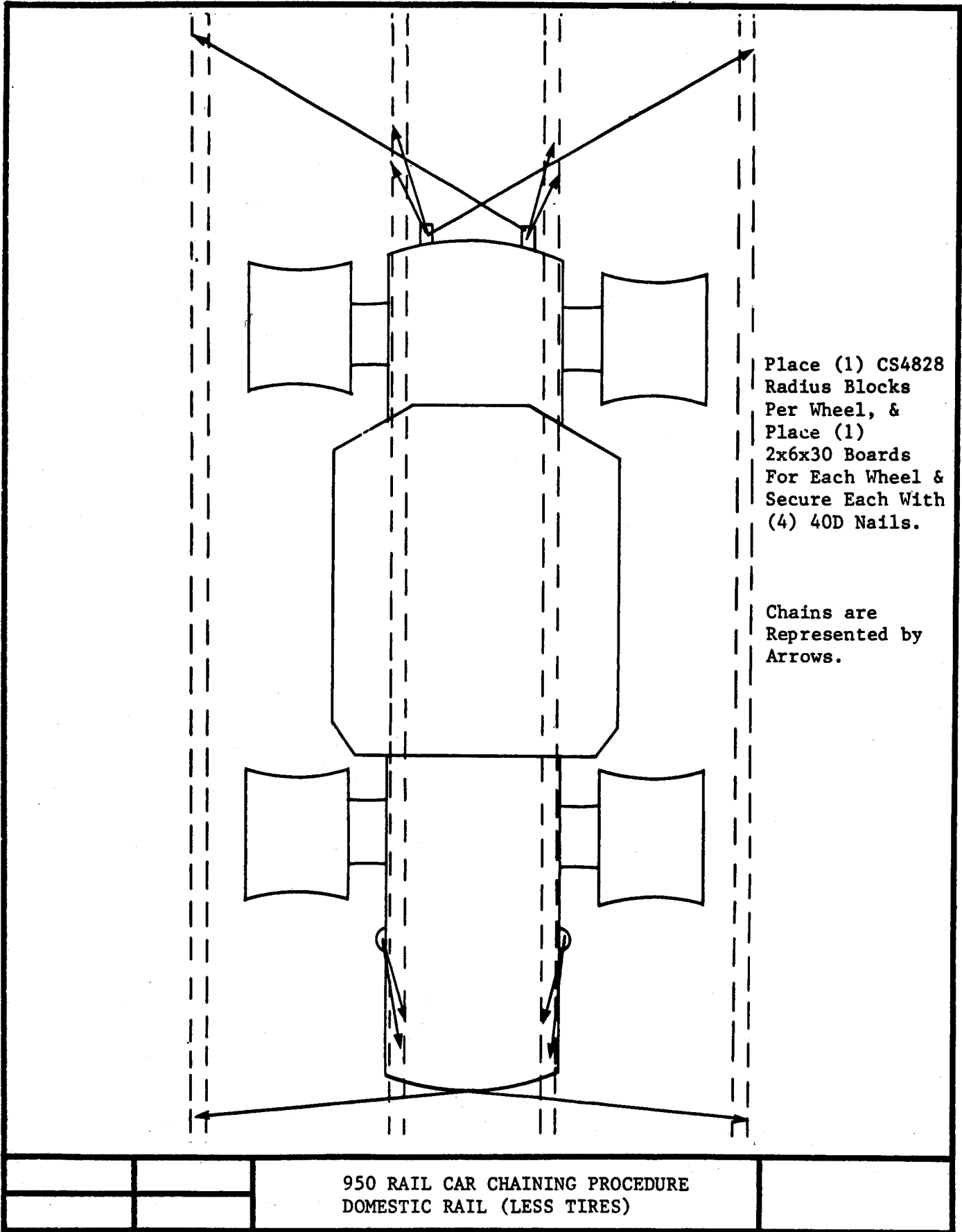

Place (1) CS4828
Radius Blocks
Per Wheel, &
Place (1)
2x6x30 Boards
For Each Wheel &
Secure Each With
(4) 40D Nails.

Chains are
Represented by
Arrows.

950 RAIL CAR CHAINING PROCEDURE
DOMESTIC RAIL (LESS TIRES)

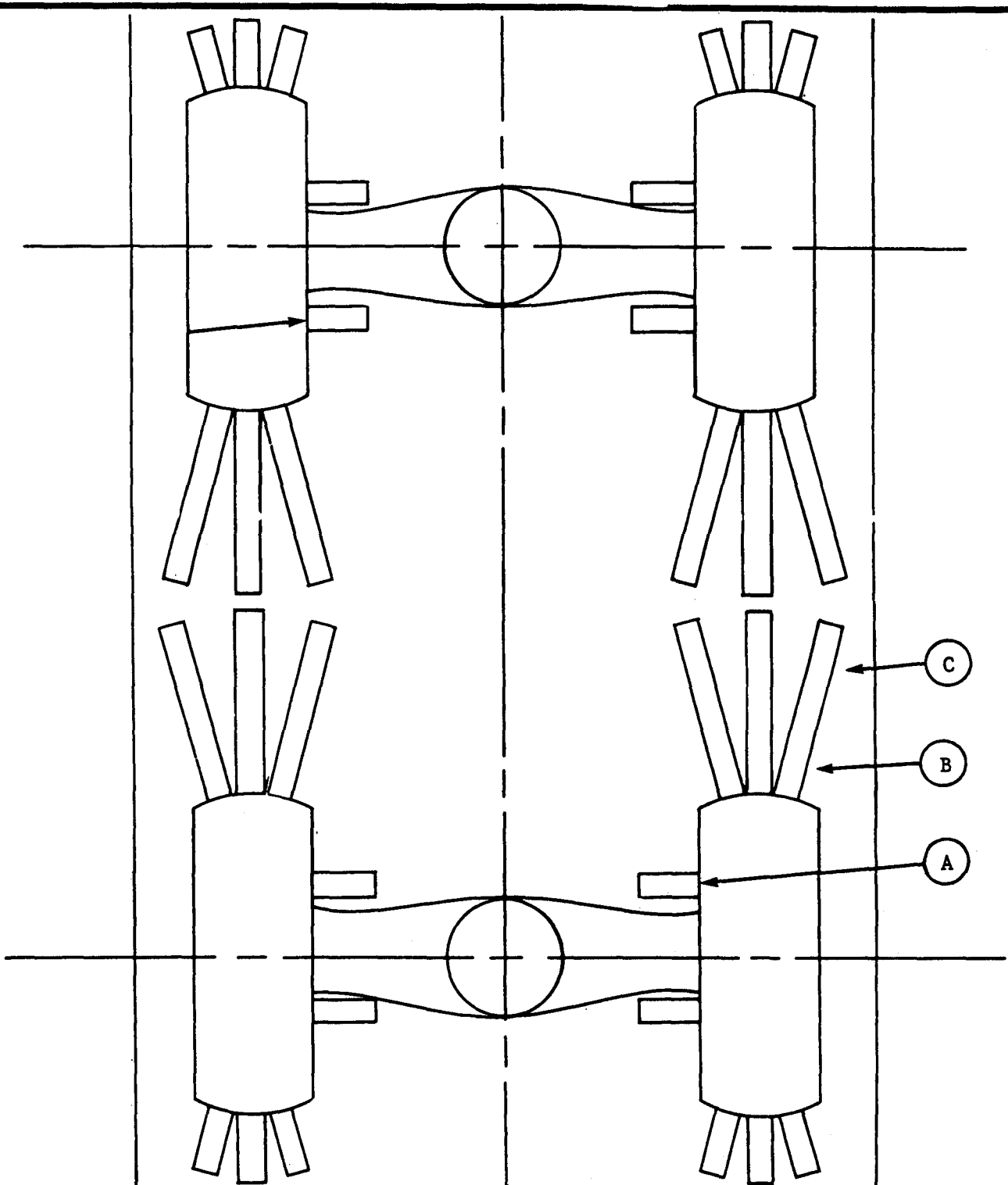

Center tractor on rail car and block as shown using CS00 rail pattern.

- A. CS24 Block (8)
- B. CS56 Block (24)
- C. CS45 Block (12)

DATE ISSUED		NAME	
DATE REISSUED		950 RAIL CAR BLOCKING PROCEDURE	

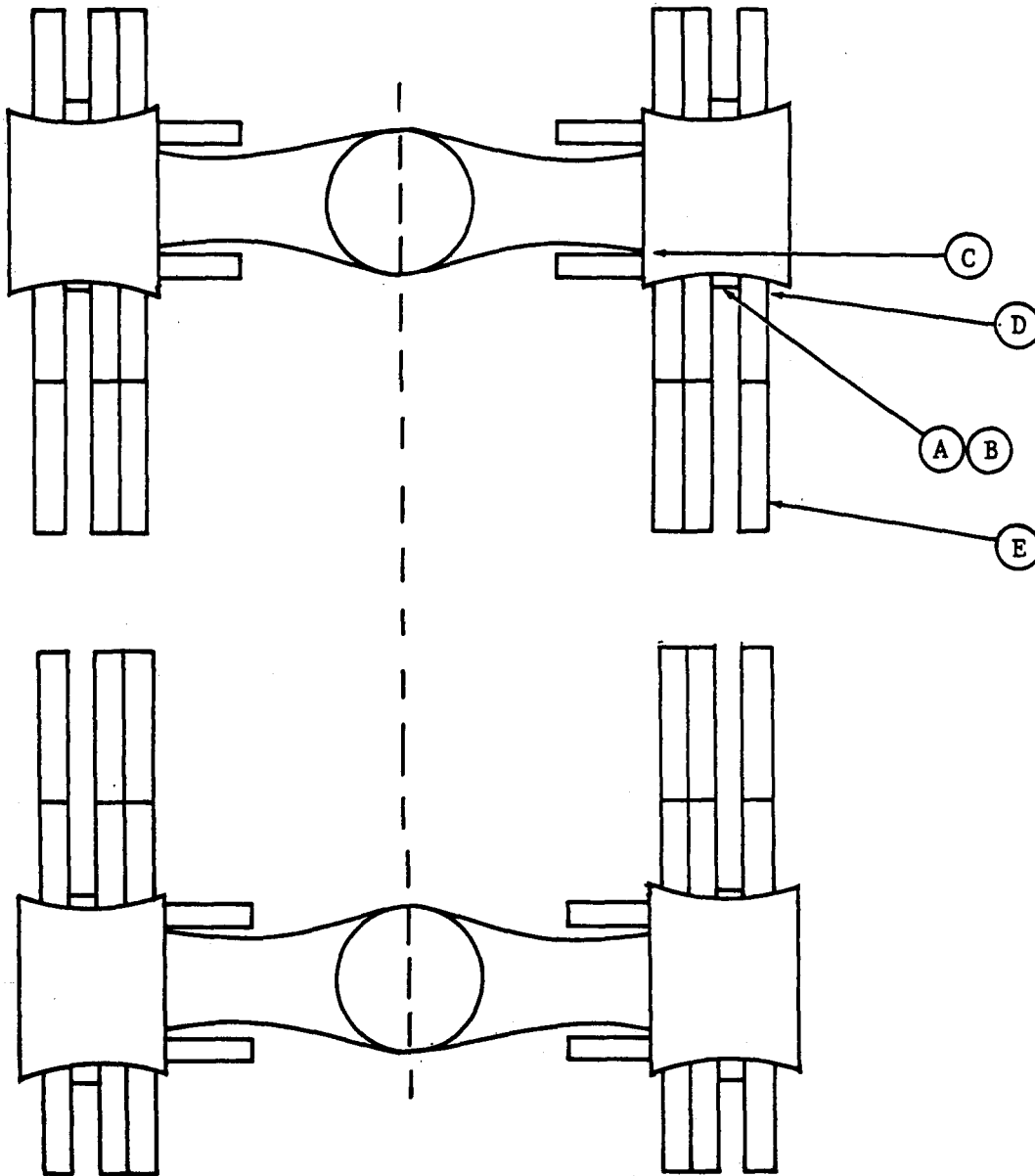

1. Center tractor on rail car using radius blocks & 2 x 6's to support tractor off railcar.
2. Block as shown using CS00 Nail Pattern.

- A. CS4828 Radius Blocks (4)
- B. 2 x 6 x 30 (4)
- C. CS24 Blocks (8)
- D. CS56 Blocks (24)
- E. CS45 Blocks (12)

DATE ISSUED		NAME	950 RAIL CAR BLOCKING PROCEDURE DOMESTIC RAIL (LESS TIRES)
DATE REISSUED			

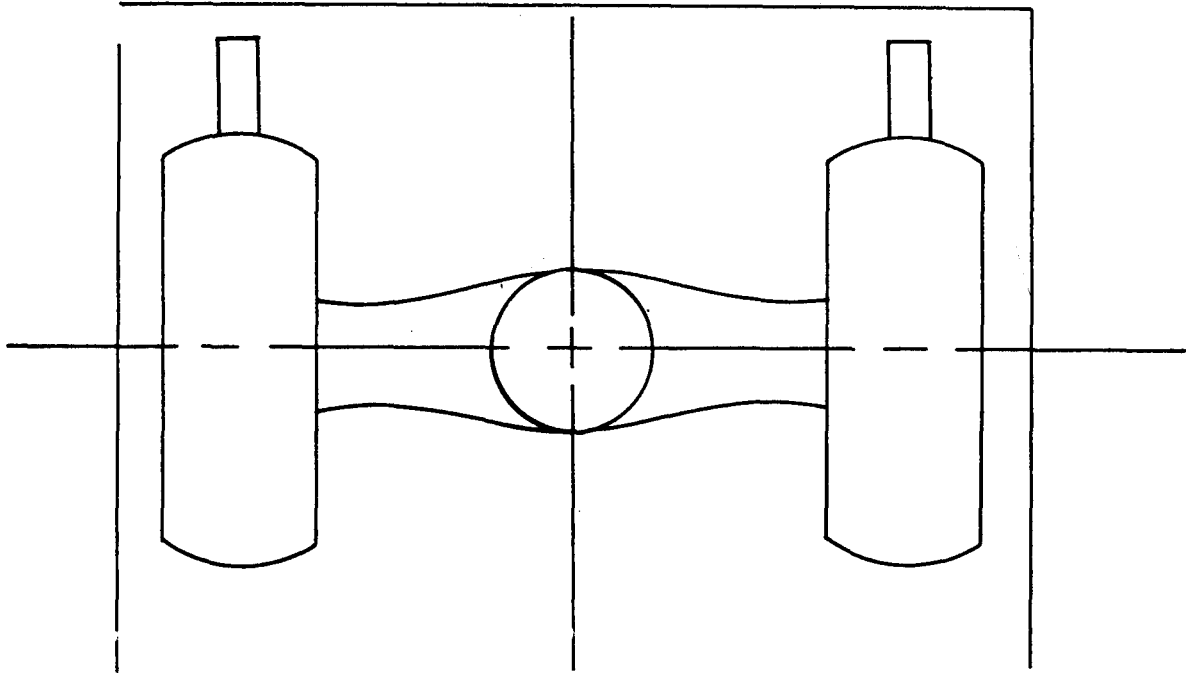

This Procedure will be used when possible in addition to chains supplied and secured by the carrier.

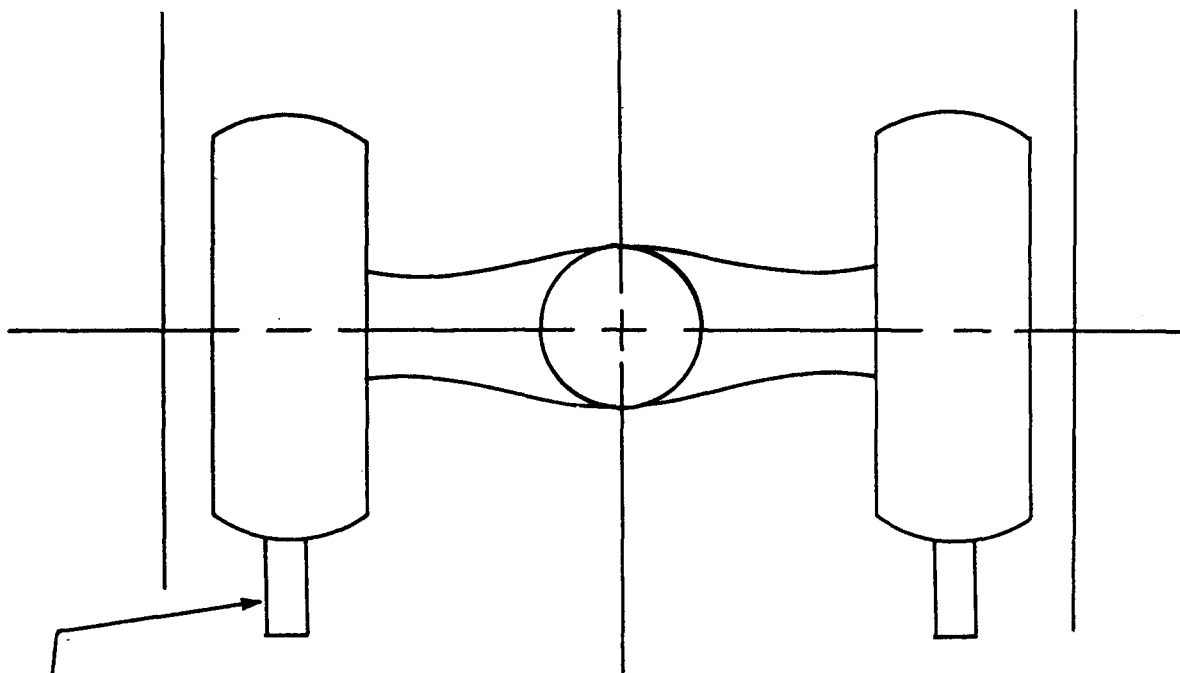

4 CS-24 Blocks required

DATE ISSUED		NAME	950 (T237) Wheel Loader
DATE REISSUED			Blocking Procedure - Domestic Truck

By Order of the Secretary of the Army:

GORDON R. SULLIVAN
General, United States Army
Chief of Staff

Official:

PATRICIA P. HICKERSON
Brigadier General, United States Army
The Adjutant General

Distribution:

To be distributed in accordance with DA Form 12-25-E (Block 2300) Unit, Direct Support, General Support maintenance requirements for TM5-3805-258-24-2.

RECOMMENDED CHANGES TO EQUIPMENT TECHNICAL PUBLICATIONS



THEN... JOT DOWN THE DOPE ABOUT IT ON THIS FORM. CAREFULLY TEAR IT OUT. FOLD IT AND DROP IT IN THE MAIL!

SOMETHING WRONG WITH THIS PUBLICATION?

FROM: (PRINT YOUR UNIT'S COMPLETE ADDRESS)
Your mailing address

DATE SENT
Date you fill out this form

PUBLICATION NUMBER
TM X-XXXX-XXX-XX

PUBLICATION DATE
Date of TM

PUBLICATION TITLE
Title of TM

BE EXACT... PIN-POINT WHERE IT IS

PAGE NO	PARA-GRAPH	FIGURE NO	TABLE NO
3		2	
109		51	
2-8			2-1
12	1-6a		

IN THIS SPACE TELL WHAT IS WRONG AND WHAT SHOULD BE DONE ABOUT IT:

Item 10. Change illustration. Reason: Tube end shown assembled on wrong side of lever cam.

Item 3. The NSN and P/N are not listed on the AMDF nor the MCRL. Request correct NSN and P/N be furnished.

Preventive Maintenance Checks and Services. Item 7 under "Items to be inspected" should be changed to read as follows: Firing linkage and firing mechanism pawl.

Since there are both 20- and 30- round magazines for this rifle, data on both should be listed.

SAMPLE

PRINTED NAME, GRADE OR TITLE, AND TELEPHONE NUMBER

SIGN HERE:

SAMPLE

FILL IN YOUR
UNIT'S ADDRESS



FOLD BACK

DEPARTMENT OF THE ARMY

OFFICIAL BUSINESS

Commander
US Army Tank-Automotive Command
ATTN: AMSTA-MB
Warren, Michigan 48397-5000

TEAR ALONG PERFORATED LINE

RECOMMENDED CHANGES TO EQUIPMENT TECHNICAL PUBLICATIONS



SOMETHING WRONG

WITH THIS PUBLICATION?

FROM: (PRINT YOUR UNIT'S COMPLETE ADDRESS)

DATE SENT

PUBLICATION NUMBER
TM 5-3805-258-24-2

PUBLICATION DATE
9 August 1991

PUBLICATION TITLE
**ORGANIZATIONAL, DIRECT SUPPORT AND
GENERAL SUPPORT - SCOOP LOADER**

BE EXACT. . . PIN-POINT WHERE IT IS				IN THIS SPACE TELL WHAT IS WRONG AND WHAT SHOULD BE DONE ABOUT IT:
PAGE NO	PARA- GRAPH	FIGURE NO.	TABLE NO	

PRINTED NAME, GRADE OR TITLE, AND TELEPHONE NUMBER

SIGN HERE:

FILL IN YOUR
UNIT'S ADDRESS

FOLD BACK

DEPARTMENT OF THE ARMY

OFFICIAL BUSINESS

Commander
US Army Tank-Automotive Command
ATTN: AMSTA-MB
Warren, Michigan 48397-5000

TEAR ALONG PERFORATED LINE

RECOMMENDED CHANGES TO EQUIPMENT TECHNICAL PUBLICATIONS



THEN... JOT DOWN THE DOPE ABOUT IT ON THIS FORM. CAREFULLY TEAR IT OUT, FOLD IT AND DROP IT IN THE MAIL!

SOMETHING WRONG WITH THIS PUBLICATION?

FROM: (PRINT YOUR UNIT'S COMPLETE ADDRESS)

DATE SENT

PUBLICATION NUMBER

TM 5-3805-258-24-2

PUBLICATION DATE

9 August 1991

PUBLICATION TITLE

ORGANIZATIONAL, DIRECT SUPPORT AND GENERAL SUPPORT - SCOOP LOADER

BE EXACT... PIN-POINT WHERE IT IS

PAGE NO

PARA-GRAPH

FIGURE NO.

TABLE NO

IN THIS SPACE TELL WHAT IS WRONG AND WHAT SHOULD BE DONE ABOUT IT:

PRINTED NAME, GRADE OR TITLE, AND TELEPHONE NUMBER

SIGN HERE:

FILL IN YOUR
UNIT'S ADDRESS

FOLD BACK

DEPARTMENT OF THE ARMY

OFFICIAL BUSINESS

Commander
US Army Tank-Automotive Command
ATTN: AMSTA-MB
Warren, Michigan 48397-5000

TEAR ALONG PERFORATED LINE

RECOMMENDED CHANGES TO EQUIPMENT TECHNICAL PUBLICATIONS



THEN... JOT DOWN THE DOPE ABOUT IT ON THIS FORM. CAREFULLY TEAR IT OUT, FOLD IT AND DROP IT IN THE MAIL!

SOMETHING WRONG WITH THIS PUBLICATION?

FROM: (PRINT YOUR UNIT'S COMPLETE ADDRESS)

DATE SENT

PUBLICATION NUMBER

TM 5-3805-258-24-2

PUBLICATION DATE

9 August 1991

PUBLICATION TITLE

ORGANIZATIONAL, DIRECT SUPPORT AND GENERAL SUPPORT - SCOOP LOADER

BE EXACT... PIN-POINT WHERE IT IS

PAGE NO

PARA-GRAPH

FIGURE NO.

TABLE NO

IN THIS SPACE TELL WHAT IS WRONG AND WHAT SHOULD BE DONE ABOUT IT:

PRINTED NAME, GRADE OR TITLE, AND TELEPHONE NUMBER

SIGN HERE:

FILL IN YOUR
UNIT'S ADDRESS

FOLD BACK

DEPARTMENT OF THE ARMY

OFFICIAL BUSINESS

Commander
US Army Tank-Automotive Command
ATTN: AMSTA-MB
Warren, Michigan 48397-5000

TEAR ALONG PERFORATED LINE

